

SCIENTIFIC AMERICAN

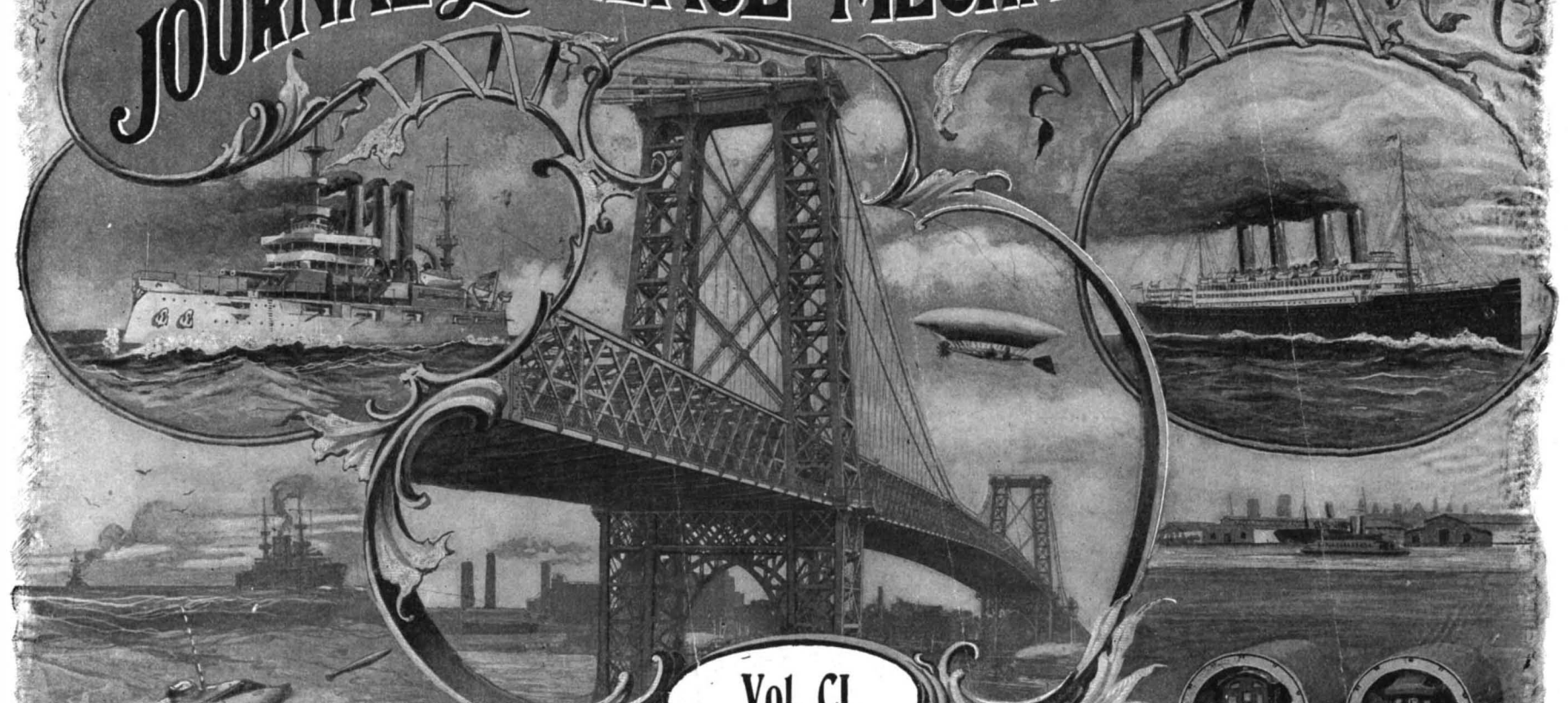

AN ILLUSTRATED
JOURNAL OF SCIENCE MECHANICS AND THE ARTS



Vol. C1.

MUNN & CO. NEW YORK

Castro 1905

SCIENTIFIC AMERICAN

[Entered at the Post Office of New York, N. Y., as Second Class Matter. Copyright, 1908, by Munn & Co.]

A POPULAR ILLUSTRATED WEEKLY OF THE WORLD'S PROGRESS

Vol. CL.—No. 1.
ESTABLISHED 1845.

NEW YORK, JULY 3, 1909.

10 CENTS A COPY
\$3.00 A YEAR.

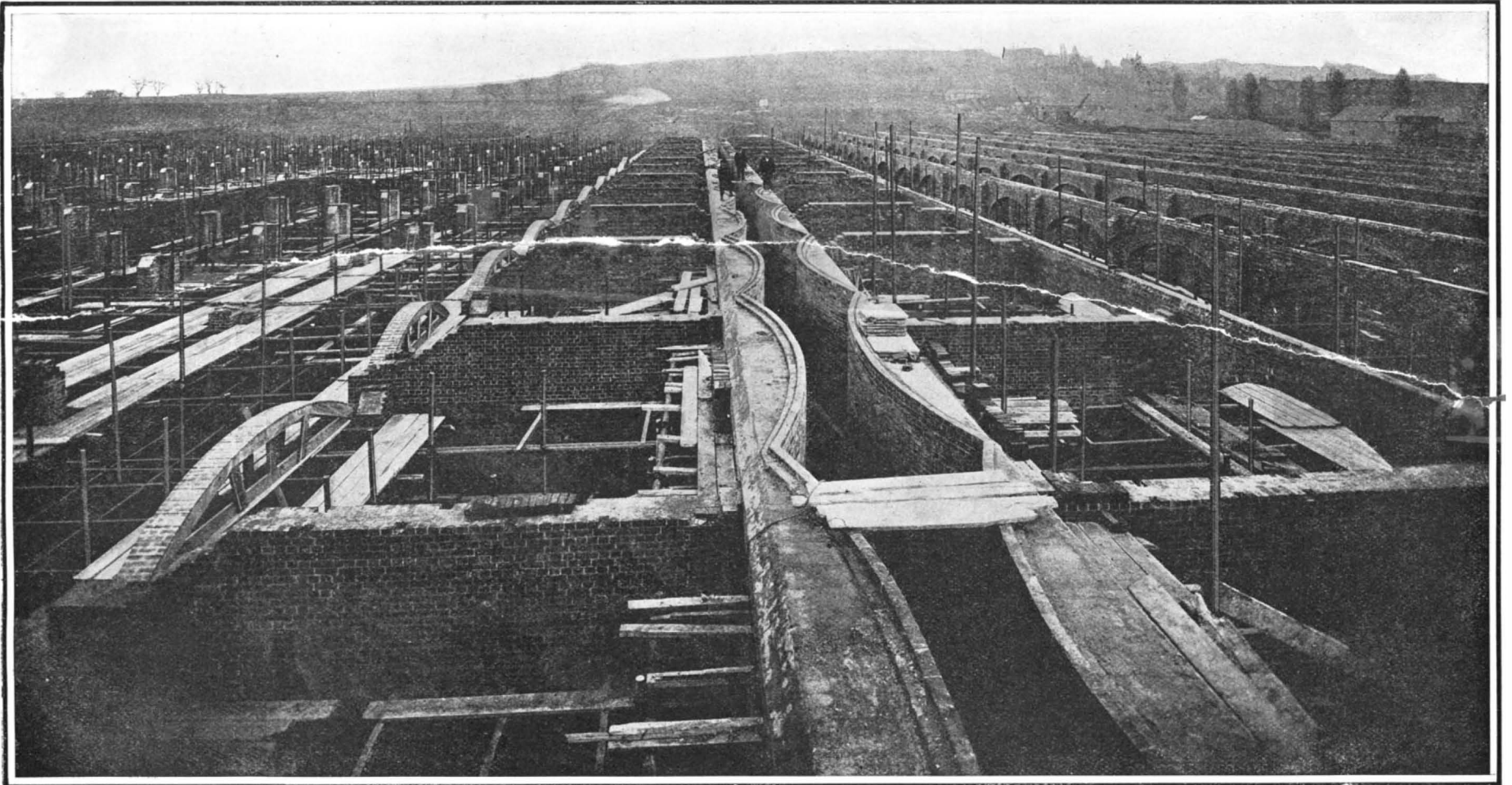

View along one of the walls which divide the reservoir into four sections. The connected backs of the walls are visible.

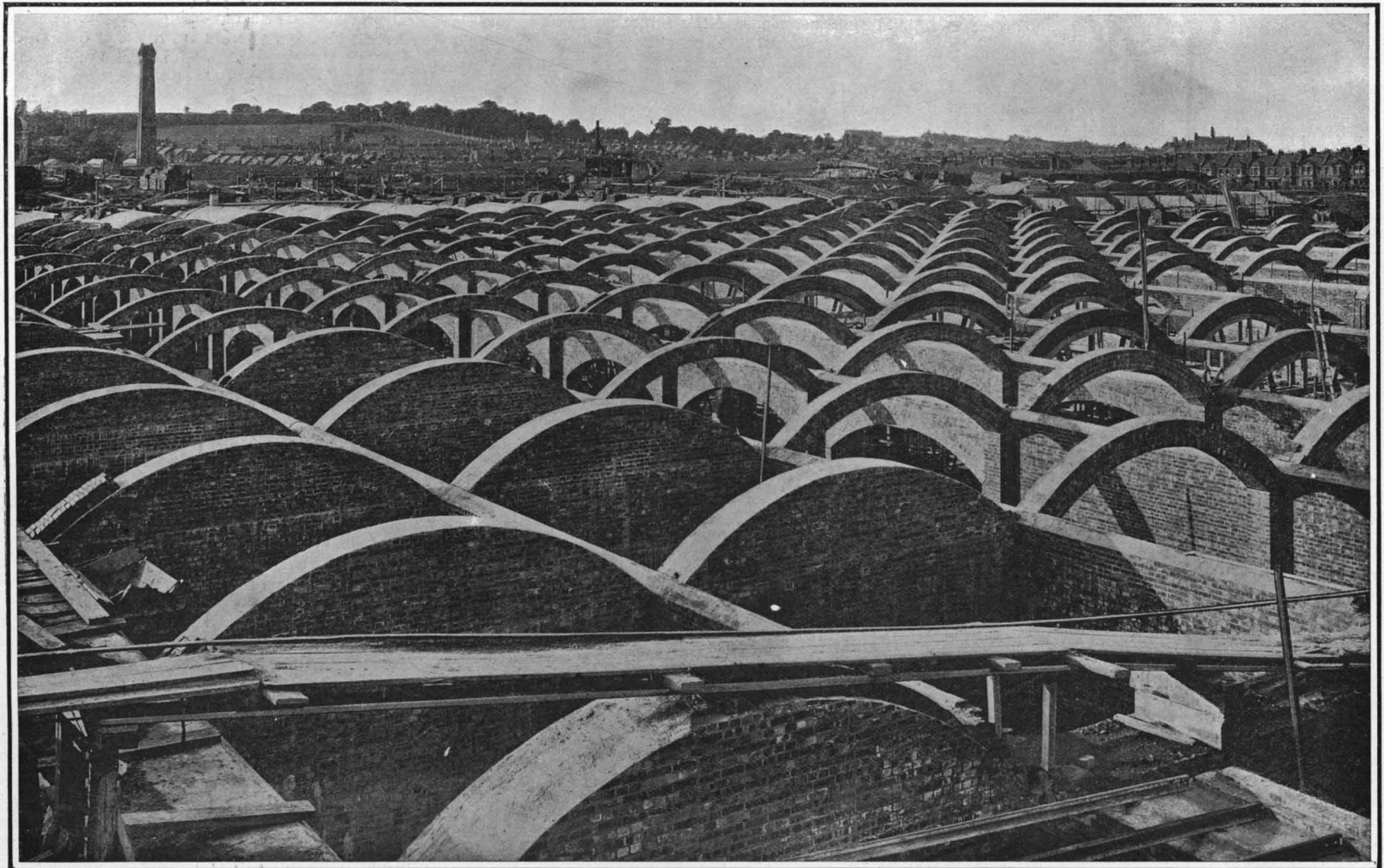

The arches that support the roof.

A HUGE FILTERED WATER RESERVOIR FOR LONDON.—[See page 11]

SCIENTIFIC AMERICAN

ESTABLISHED 1845

MUNN & CO. - - - Editors and Proprietors

Published Weekly at
No. 361 Broadway, New YorkCHARLES ALLEN MUNN, *President*
361 Broadway, New York.
FREDERICK CONVERSE BEACH, *Sec'y and Treas.*
361 Broadway, New York.

TERMS TO SUBSCRIBERS.

One copy, one year, for the United States or Mexico \$3.00
 One copy, one year, for Canada 3.75
 One copy, one year, to any foreign country, postage prepaid, 18s. 6d. 4.50

THE SCIENTIFIC AMERICAN PUBLICATIONS.

Scientific American (established 1845) \$3.00 a year
 Scientific American Supplement (established 1876) 5.00 "
 American Homes and Gardens 3.00 "
 Scientific American Export Edition (established 1878) 3.00 "

The combined subscription rates and rates to foreign countries, including Canada, will be furnished upon application.

Remit by postal or express money order, or by bank draft or check.

MUNN & CO., 361 Broadway, New York.

NEW YORK, SATURDAY, JULY 3rd, 1909.

The Editor is always glad to receive for examination illustrated articles on subjects of timely interest. If the photographs are sharp, the articles short, and the facts authentic, the contributions will receive special attention. Accepted articles will be paid for at regular space rates.

FACT AND FANCY IN AERONAUTICS.

Somebody has said that the successful inventor is usually more or less of an idealist, and invariably is possessed of a strong imagination. Judging from the wild flights of fancy upon which an epoch-making invention serves to launch the innumerable army of magazine writers, we might add that in addition to being an imaginative idealist, he would seem to be something of a hypnotist as well.

As a matter of fact, although the inventors of the steam engine, the telegraph, and the flying machine were necessarily possessed of a creative imagination, they were essentially of a practical and conservative turn of mind. Stephenson, Morse, Marconi, and the Wright brothers may have found time in the midst of their busy hours to glance at the future, and be momentarily thrilled at the thought of its splendid speculative possibilities; but in the main they were too conscious of the inherent limitations of their inventions, too strongly engrossed in the effort to work out patiently each nearest problem as it arose, to indulge in wild prophecy of future accomplishment.

The attitude of the Wright brothers during their wonderful demonstration of the possibility of mechanical flight may be referred to as proving the truth of the above observations. Although they have created the art, at least as far as its practical expression is concerned, we doubt if anyone who has spoken or written on the subject of the development of flight has been more reluctant to predict the achievements of the future, or more conservative in pointing out the inherent limitations of the art. On the other hand, it is rarely that the birth of a new invention has brought forth such a flood of preposterous and impossible literature as has appeared during the last few months on the military and commercial future of the dirigible and the aeroplane.

Without in the least disparaging the fine achievements of Lebaudy, Zeppelin, the Wright brothers, Curtiss, Farman, Bleriot, and others, whose intelligence, pluck, and perseverance have made aerial flight the sensation of the day, we wish to draw attention to the fact that in their present state of development, neither the dirigible nor the aeroplane has the slightest practical military value. The best that can be said of them is that when certain inherent defects have been overcome, they may, in a limited degree, be put to military use. At the present writing this field would seem to lie exclusively in the direction of scouting and the carrying of dispatches.

In proof of this, we point to the fact that at present both the dirigible and the aeroplane, and particularly the latter, require, both for their starting and landing, the provision of a large, fairly level field or campus, free from the obstruction of trees, telegraph poles and wires, and buildings. In the case of the aeroplane, it is even necessary for safe starting and stopping that the surface be free from tall weeds or grass; for should the machine in coming to the ground dip sufficiently for one wing to sweep in among the long grass, the contact is sufficient to swing it violently around across its course, at the risk of wrecking the chassis or runners. Furthermore, the well-known reluctance of the aeronaut to start into the air in anything stronger than a moderate breeze, particularly if the wind be variable, is very significant of the pres-

ent crude condition of the art considered in respect of its commercial or military value. We do not hesitate to affirm that there are many years of patient mechanical development and practice in the air ahead of us, before we shall see the production of an aeroplane which can arise or alight (as it must necessarily do to be of practical value) with that independence of time, place, and weather conditions which marks the flight and the coming and going of the birds of the air.

Perhaps the most absurd of the military claims made for the airship and aeroplane is that of their ability to sail over hostile territory and destroy cities, fortifications, and military depots by the expedient of dropping high explosives. In view of the great range of modern artillery, and the fact that a special type is now being developed to repel airship attack, the machine must operate at a height of at least a mile above the earth, if it is to be safe from shrapnel and the special shells which will be furnished for its destruction. At that height it would be a question of the merest chance if a bomb released from the machine struck the object aimed at. There would be no means of determining if the fort, magazine, etc., was in exact vertical alignment at the moment the missile was dropped. Allowance would have to be made for the velocity of the wind which velocity could not be known to those who were moving in midair. Moreover, the direction of the flight of the projectile would be the resultant of the vertical velocity, due to gravity, and the horizontal velocity of the ship itself. Consequently, to make a hit, the projectile would have to be released before the machine was vertically over the object, and at a certain specified distance ahead of the vertical line. How would the operator determine the exact moment at which to let go? It is evident that even approximately accurate aiming would be out of the question; and the limited amount of ammunition which could be carried, even by a large dirigible, would render an attempted bombardment the most foolish kind of a farce. The 11-inch high-explosive shells with which the Japanese bombarded the Russian fleet in Port Arthur failed to inflict vital damage. It is now well known that the Russian ships were sunk by the Russians themselves, who opened the seacocks and flooded them. In the many weeks of bombardment, the Japanese hurled hundreds of tons of 11-inch shells on the Russian fortifications, fleet, and buildings without bringing Port Arthur to capitulation. It was the sappers and miners that reduced the fortress. The damage that would be inflicted on a beleaguered city by a whole fleet of dirigibles could never by any possibility have a decisive effect upon the issues of the war.

We repeat that the present indications are that the airship and aeroplane of the future, even when they have been developed to their ultimate perfection, will find their field of usefulness exclusively in the work of scouting and the carrying of dispatches.

THE CAPE COD CANAL.

The turning of the first sod in the work of cutting the Cape Cod canal on Tuesday, June 22nd, which took place on the farm on which Commodore Perry of Lake Erie fame was born, was an event of more than local significance. Great as the value of the canal will be in shortening the sailing distance between New York and Boston, and avoiding the perils of navigation around the greatly dreaded Cape Cod, the new waterway will ultimately take on a national and military value as forming an important link in that future system of related canals along the Atlantic seaboard, which has come to be known as "the inside route," by which it will be possible for shipping to make the voyage from Boston to Norfolk Va., in sheltered bays, inland waters, and reaches of canal, without once passing outside the ultimate coast line.

The canal will extend for eight miles from Barnstable Bay to Buzzards Bay, and at each entrance will be approaches which will bring the total length of the canal up to 12 miles. It will have a surface width of from 250 to 300 feet, a bottom width of 160 feet, a least depth at low water of 25 feet, and a mean high-water depth of about 30 feet. The canal will be built at sea level, and with these generous dimensions it should prove adequate for many years to come for the class of coastwise freight and passenger steamers that will make use of it.

The Cape Cod canal will form, then, the first link in a chain of interior waterways, which, because of its commercial and military value, is certain of ultimate construction. A ship sailing from Boston for Norfolk, after leaving the southerly entrance to Cape Cod canal, would run through Buzzards Bay into Long Island Sound, and thence by way of the East River and New York Bay to the Raritan River. From the Raritan it would proceed by canal across New Jersey to the Delaware River, and the present canal from the Delaware River to Chesapeake Bay, after deepening, would carry the ship to deep water, in which she could reach Norfolk on a clear course. In

the preliminary surveys and plans for this route, it is not contemplated to build the canals and channelways on the southerly portion of the route of the same capacity as the Cape Cod canal. Ultimately, as trade developed, this section would be widened and deepened to accommodate a larger type of ship.

The advantage of the inside route from the military point of view is that it would make it possible to transfer gunboats, torpedo boats, and submarines from one fort or harbor to another, without interference by a blockading fleet of the enemy. The advocates of the canal claim that the elimination of the dangers of the outside coast route, especially at Capes Cod and Hatteras, would greatly stimulate the coastwise trade, the increase of which, coupled with the reduction in the time of passage, would have a marked effect in cheapening the cost of the transportation and reducing railroad rates. It is estimated by the engineers that the Cape Cod canal will be completed in from three to four years, at a cost of \$12,000,000. The borings along the route have revealed the existence of sand and gravel with some clay, and the work of construction will be mainly one of straightforward dredging.

THE COPYRIGHT ACT.

The new copyright act, about which there has been so much agitation for the past two or three years, is now an accomplished fact, the provisions of the act having gone into effect on July 1st, 1909. The new measure cannot be said to be amendatory in any way, for it prescribes an entirely new form of procedure.

For a long period of time, lawyers when advising their clients with reference to the requirements which should be followed to obtain copyright protection in the United States, have emphasized the necessity of complying with the provisions of the copyright act before the subject matter is published. The new act completely upsets this long-established practice, for it provides unqualifiedly for the publication of a book or other such work, with the notice of copyright printed thereon, as the first step toward procuring the protection desired. After the publication of the work, with the notice of the copyright, an application for copyright registration must be filed with two copies of the work. In cases where the work is not to be reproduced in copies for sale, the registration is secured by filing with the application a manuscript or typewritten copy if the subject matter be an oral address, a dramatic composition, or a similar work, and should the subject matter be a drawing, sculpture, or a similar work, a photograph thereof should be filed with the application.

When a book of foreign origin is printed in a foreign language, it is unnecessary that the book be printed in the United States; but this is an exception to the general provision, which requires that the printing of a book shall take place within the limits of the United States. Books published abroad in the English language may be protected by an *ad interim* copyright, but the application must be filed within thirty days of the publication abroad, and as the term of the *ad interim* copyright is only thirty days, it is necessary to reprint the book in the United States and publish it not later than during the sixty days following the foreign publication.

The scope of a copyright registration of a musical composition has been extended to enable the proprietor to prevent others from copying the subject by mechanical means; but should the proprietor permit the subject matter to be reproduced by such mechanical means, he may be compelled to grant licenses permitting others to use the subject matter on similar means for reproduction, the licensee to pay a reasonable consideration for the grant of the license.

The term of the copyright registration is still twenty-eight years, but the renewal term has been extended from fourteen years to twenty-eight years.

At the First Census but six cities reported a population of approximately 8,000 inhabitants. Compared with this number, in 1900 there were two hundred and eighty-six cities and towns in the same area having a population of 8,000 or more. In Rhode Island alone, the smallest of all the States, there were more cities of 8,000 inhabitants than there were in the entire United States in 1790. The aggregate population of all cities in the area enumerated in 1790, which in 1900 reported more than 50,000 inhabitants, was 185,207 in 1790, and 10,259,186 in 1900. Although the total population of the United States increased rapidly from 1790 to 1900, the relative population weight of New York, Philadelphia, Boston, and Baltimore increased even more rapidly. In 1790 their combined population was but little more than 100,000 and formed but 2.4 per cent of the population of the Republic; but in 1900 it was approximately 6,000,000, or nearly 58 times as great as in 1790, and formed 7.6 per cent of the population of the Republic. The population in 1900 of the area actually enumerated as comprising these four cities in 1790 was 590,699, or a sixfold increase of population within the original city limits.

ENGINEERING.

The cost of foundations for new buildings in New York runs at times into very high figures. The contract for the foundation work of the new 25-story Municipal Building to be erected at the Brooklyn Bridge entrance has just been let to the Foundation Company for \$1,443,147. The caissons must be carried down below the Subway station to rock, which lies in places 80 feet below street level.

The work of constructing the Cape to Cairo Railway is to be started again in the near future. The present end of the line is 370 miles north of Victoria Falls, and it is expected to carry the line into the Congo copper district during the present season. The new line will not be an all-rail route. A considerable part of the distance will be covered by steamers on the great interior lakes of Africa.

Both Canada and Australia have followed the lead of New Zealand in the decision to contribute to the naval defense of the empire. The federal government of Australia has voted to build one "Dreadnought" for the British navy. The Canadian government will build and man a navy of its own, to act as an auxiliary force to the fleet of Great Britain. The plans call for the construction of eight first-class cruisers of the "Cornwall" type, of 10,000 tons displacement, ten torpedo-boat destroyers, and ten torpedo boats. The fleet will be built in Great Britain, and the time and cost of construction are to cover the next five years.

It is well known that the amount of snowfall in the Rocky Mountains determines the flow of water in the leading rivers that head in this range. Consequently, the snowfall has an important bearing in determining the volume of the floods which frequently devastate the middle Western States. Many of the most important irrigation ditches, moreover, depend for their supply upon the annual snowfall. To place it in a position to make an accurate forecast of the amount of water that will be released by the melting snow, the United States Weather Bureau has established a series of snow-gaging stations in the Rocky Mountains.

Two self-contained motor street cars operating independently of underground or overhead conductors, are to receive an important test on some of the branch lines of the Third Avenue Company in New York city. One of these will be of the storage-battery type, and the other will be driven by a combined gasoline-electric engine. The gasoline engine will drive an electric generator, whose current will be fed to the motors at the axles. If the experiment is a success, several lines whose business would not stand the large initial outlay for trolley construction, will be equipped with whichever car of the two types proves more serviceable.

It is stated that the Union Pacific Railway is planning to plant its right of way from the Missouri River to the Pacific with alfalfa. At each edge of the right of way also will be planted a row of pine trees alternating with elms, there being a tree at intervals of every two rods. As the alfalfa becomes green early in the spring and remains so until late in the fall, the ornamental effect should be decidedly pleasing. Furthermore, it is claimed that the grass and trees will furnish, in certain localities, a decided protection against snowdrifts and washouts. It is stated that the Chicago, Milwaukee & St. Paul Railroad proposes to do similar planting and grassing between Ottumwa and Kansas City.

In one of a series of articles on English railways in the Railroad Age Gazette, the writer, W. W. Turlay, states that the most important things we can learn from freight service in England are prompt dispatching and delivery. Small lots of freight are collected by the railroad company's own wagons, taken to the station, forwarded, and delivered during the forenoon of the following day to the consignees by the railway company's wagons. A wholesale merchant in London can have a case of dry goods taken from his warehouse in the afternoon, and count on its being delivered to his retail customer in Manchester, 183½ miles distant, the following morning at rates of from 72 cents for 112 pounds to \$1.80 for 336 pounds, and for amounts above 336 pounds at the rate of 43 cents per 100 pounds.

A notable step in the preliminary work of selecting the site for a bridge across the Hudson River, to be built jointly by the States of New York and New Jersey, was taken when the Governors of the two States recently inspected the two sites which had been selected as the most available, one at 179th Street, and the other at 59th Street. A bridge at 59th Street would cost \$30,000,000, and one at 179th Street, \$10,000,000. The 59th Street site was favored by the Governor of New Jersey, and the 179th Street location by the Governor of New York. A bridge at 59th Street would have the great advantage of providing a direct route from Jersey through 59th Street and over the new Queensboro Bridge to Long Island. Furthermore, it would tap one of the most important business centers on Manhattan Island.

AERONAUTICS.

Saturday, June 26th, was the hottest day of the year so far, and the fact that about 2,000 people made the ¾-hour journey via subway and trolley car to Morris Park, Westchester, and paid \$1 each for admission, augurs well for the future exhibitions of flight which the Aeronautic Society proposes to hold at frequent intervals throughout the summer. Last Saturday, for the first time, New Yorkers had an opportunity to witness a flight by a heavier-than-air flying machine, and great credit is due the energetic officers and members of the Aeronautic Society for having provided this exhibition at a time when the attention of the public is drawn to the subject of flying by Orville Wright's second attempt to fulfill the government requirements of a one hour flight with passenger and a 10-mile cross-country speed test at Fort Myer on the outskirts of Washington, D. C. With the exception of this gentleman, Glenn H. Curtiss is the only other American aviator who has publicly flown in our country, and Saturday was the first time he had ever made an exhibition flight before a large crowd of spectators. On July 4th last he became the first winner of the SCIENTIFIC AMERICAN Trophy by making a mile flight across the fields in the aeroplane "June Bug" at his home at Hammondsport, N. Y. Mr. Curtiss was at that time a member of Dr. Alex. Graham Bell's Aerial Experiment Association, and the "June Bug" was the third successful aeroplane which the association had built. His new biplane, which he has constructed for the Aeronautic Society, is the lightest and fastest aeroplane of this type ever produced, and the flights executed with it last Saturday showed it to be an excellent flyer. In a speed test it traveled 46.7 miles an hour, its small size (29 feet spread), light weight (400 pounds complete), and slight head resistance making it considerably faster than the Wright machine, although it has only the same power (25 horse-power).

The visitor at Morris Park last Saturday found much that was interesting on exhibition on the lawn in front of the grand stand. There were several aeroplanes not quite completed, as well as models and a full size helicopter intended to be worked by foot power by two men. The blades were rotated in this manner but the machine showed no tendency to rise. There was sufficient breeze for some school boys to fly with kites, and a score of them had a contest. At about 4 P. M. Mr. Curtiss made his first straight-line flight. Starting near one end of the track, he flew nearly to the other end and alighted in front of the grand stand. He then turned the machine around and flew back again. Each flight was about a third of a mile in length. Next Mr. William H. Martin, a farmer and civil engineer of Canton, O., was towed in his glider by a Kissel automobile. This glider is a monoplane with planes beneath it set at a dihedral angle. It is provided with rudders and mounted upon a boat-shaped frame on three wheels. The auto towed it too fast and the glider got swaying badly. Then the rope broke and the machine swerved to one side and smashed through the picket fence. Mr. Martin, who is quite a heavy man, was thrown over the fence upon the lawn. Fortunately he received no serious injuries. The society's wind wagon, which has a 24-horse-power, 4-cylinder air-cooled motor and an 8-foot propeller, made several sprints around the track at a 30-mile-an-hour clip and managed to cast a tire off of one of the steering wheels. It next engaged in a tug-of-war with an ancient 2-cylinder Autocar runabout. If it could get a start and jerk the runabout, it could pull the latter backward, but otherwise the latter was the victor. Two hot-air balloons were inflated and sent up with a man and a woman respectively. Both aeronauts made successful parachute jumps and landed on the grounds. Very late in the afternoon Frederick Schneider was shot off by the catapult in his Wright-type aeroplane fitted with the Society's motor, but even though the propellers were running nicely, the machine only traveled 25 or 30 feet beyond the end of the rail, the thrust developed by the propellers being insufficient to make it fly.

It was nearly 8 P. M. before the breeze died down sufficiently to enable Mr. Curtiss to make a flight with turns. Most of the spectators remained, however, and they found it well worth while. Starting again from the end of the track farthest away from the grand stand, he flew down past the spectators at a height of 25 feet, gracefully circling round the small bend and traveling rapidly up the other side of the course. Then he turned again and alighted at the wide end of the egg-shaped track. The spectators cheered and applauded throughout the entire flight, which lasted about 2 minutes. While by no means so noisy and dusty as the first track automobile races used to be, this first circular flight above a race track in America was truly spectacular, and without doubt, when it is repeated and prolonged into repeated circlings, many more thousands of people will flock to see it. It is probable that on July 5th Mr. Curtiss will attempt to set up a record for the SCIENTIFIC AMERICAN Trophy.

SCIENCE.

Lieut. Shackleton has returned to England. He will lecture before the Royal Geographical Society on his Antarctic discoveries.

Prof. George E. Hale of the Mount Wilson Observatory has been honored in France by his fellow scientists. His researches on the sun and on stellar evolution are regarded as authoritative.

The largest order for radium in the history of radioactivity was placed jointly by Sir Ernest Cassel and Lord Iveagh. The quantity ordered is 7½ grammes, equivalent to about ¼ avoirdupois ounce, and the price is \$150,000. This quantity of radium is to be donated to the Radium Institute, to which attention has already been called in these columns.

A Chinese takin has been mounted in the American Museum of Natural History. The animal was captured in the mountainous regions of China, and was presented to the museum by Mason Mitchell, former American consul to China. The takin has the characteristics of an antelope and a goat.

It is said that a new supply of radium has been discovered in Portugal by Thomas H. V. Bower, a member of the American Institute of Mechanical Engineers. A certain stream, the name of which is not disclosed, was reputed to have therapeutic properties. Mr. Bower followed the stream to its source, and discovered that it ran over a bed of uranium phosphate.

Observations of the height of clouds made by directing a searchlight vertically upward and determining the angular elevation of the illuminated patch of sky from a fixed base station were continued at the astronomical observatory at Vienna during the summer of 1908. The results show that media capable of reflecting light were frequently found to exist at heights greater than 10 kilometers. The column of light could be traced up to an altitude of 17.1 kilometers on May 31st, and to 16 kilometers on July 27th. The greatest cloud height was observed at 8 kilometers. The height of the dust or smoke layer over the city was fixed on two occasions at 300 meters and 120 meters respectively. Confirmatory observations were made occasionally from a second station distant 8.3 kilometers from the source of light.

The substances commonly used for impregnating roofing paper and roofing cloth are not permanent in the air. The desideratum is a substance of slight volatility and high boiling point, which would be durable when exposed to the air and would resist high temperatures. India rubber fulfills these requirements, but it is too expensive for use. A recent German patent describes the preparation of a cheap substitute for India rubber for this purpose. The pitch-like residues of petroleum, coal tar, certain animal substances (wool grease and other fatty matters) and some mineral substances (ozokerite and mineral wax) are exposed at a high temperature to a blast of air and to the oxidizing action of manganese dioxide and sulphuric acid, and are subsequently treated with formaldehyde.

A series of experiments has been made by T. Koerner in Germany in order to find out what proportion of alcohol can be obtained from wood, using the well-known process of converting the wood into sugar by hydrolysis and then using the sugar to form alcohol by fermentation. He made tests with sawdust, wood pulp, and like materials. The matter was treated with dilute sulphuric acid and heated in a digester in which the pressure could reach 10 atmospheres. It is to be noted that all the sugars are not fermentable, so that the percentage of alcohol must be obtained directly after the fermentation and is not to be estimated from the amount of sugar. The addition of sulphurous gas, which is sometimes recommended, is found to be a drawback for the production of alcohol. He finds that the yield of alcohol is low at best. For wood paste it is not more than 12.8 per cent, and for dry wood 6 per cent. From the present tests, he concludes that it is not commercially practicable to obtain alcohol from wood in the above way.

The determination of the characters of fibers composing a fabric, by means of combined microscopic and chemical examination, is often made impossible by interference with the characteristic reactions by the dyestuffs and metallic salts with which the fabric is loaded. On the other hand, the usual methods of removing dyes from specimens are apt to injure or destroy the fabric. In a method proposed by Copetti the dye is discharged by means of hydrofluoric acid. The sample of fabric is steeped five or ten minutes in commercial hydrofluoric acid contained in a leaden vessel. It is then washed in water, treated successively with soap, 5 per cent hydrochloric acid, hypochlorite of lime, again with hydrochloric acid, and is finally washed and dried. The dye may also be completely removed by treatment with permanganates and sulphurous acid after the hydrofluoric acid bath. This process leaves the fibers intact, so that they can be recognized by microscopic examination and other tests.

THE FOURTH DIMENSION SIMPLY EXPLAINED.

The Essay that Won the \$500 Prize Offered by a Friend of the Scientific American
BY "ESSAYONS" (LIEUT.-COL. GRAHAM DENBY FITCH, CORPS OF ENGINEERS, U. S. A.)

It is impossible to form a mental picture of the fourth dimension. Nevertheless, it is not an absurd-

3-plane is perpendicular to every right line of the other.

The position of a point in a plane may be determined by its distance from each of 2 perpendicular right lines; in our space, by its distance from each of 3 mutually perpendicular planes; and in hyperspace, by its distance from each of 4 mutually perpendicular 3-spaces. In hyperspace these distances are accordingly measured along 4 mutually perpendicular right lines, which, taken by twos, determine 6 mutually perpendicular planes; and, taken by threes, determine the above-mentioned 4 mutually perpendicular 3-spaces. Just as in our space it requires at least 3 points to determine a plane so in hyperspace it requires at least 4 points to determine a 3-space. A 3-space may also be determined by

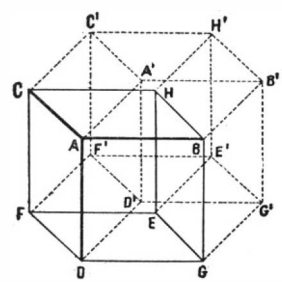

Fig. 1.

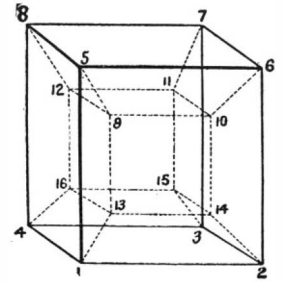

Fig. 2.

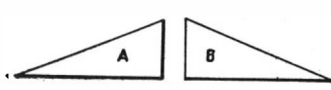

Fig. 3.

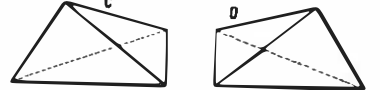

Fig. 4.

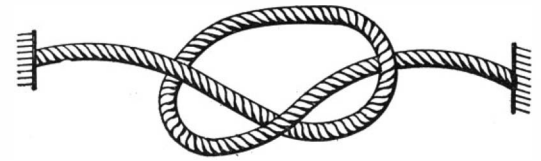

Fig. 5.

June 10, 1909.

Messrs. Munn & Co.,
361 Broadway, New York.

Gentlemen:-

We, the undersigned, have carefully examined the essays submitted in the Fourth Dimension Prize Competition of the Scientific American, and have agreed that the prize should be awarded to the author of the manuscript bearing the pseudonym "Essayons".

Faithfully yours,
Henry P. Munn
J. A. Mitchell

ity, but a useful mathematical concept with a well-developed geometry involving no contradictions. To gain a partial and symbolic idea of its meaning, resort must be had to analogy with dimensions of a lower order.

An aggregate is said to be one, two, or three-dimensional according as one, two, or three numbers are necessary to determine any one of its elements. Considering space as an aggregate of points, a line is a one-dimensional space, because to determine the position of any point on it one number, giving its distance from some fixed point, suffices. Similarly, a plane is a two-dimensional space, and the point aggregate of ordinary space is three-dimensional. Thus, the exact position of any point of the earth is known when its latitude, longitude, and elevation above sea level are given. Now, if we have four variable, related quantities, each capable of assuming, independently of the others, every possible numerical value, we obtain a four-dimensional aggregate. Such an aggregate, if of points, constitutes four-dimensional space.

If we connect all points of our space (a 3-space) with an assumed point outside of it, then the aggregate of all the points of the connecting lines constitutes a 4-space (hyperspace). Again, just as a point moving generates a line, just as a line moving outside itself generates a surface, and a surface moving outside itself generates a solid; so a solid moving outside of our space generates a hypersolid, or portion of hyperspace. Or hyperspace itself may be conceived as generated by our entire space moving parallel to itself in a direction not contained in itself, just as our space may be generated by the similar motion of an unlimited plane, which may itself be generated by an unlimited right line. Any space is that which forms the boundary between two portions of a higher space, and just as every unlimited plane divides our space into two equal infinite parts, so every 3-space divides hyperspace into two equal infinite regions between which that 3-space forms a boundary of an infinitely small thickness in the fourth dimension.

Two plane figures (say triangles) if in the same plane may partially coalesce, but cannot intersect unless in different planes, similarly two volumes (say cubes) if in the same 3-space may partially coalesce but cannot intersect unless in different 3-spaces. In hyperspace we have the following possible intersections: A hypersolid and a 3-space intersect in a solid, two 3-spaces in a plane, three 3-spaces in a right line, four 3-spaces in a point, a 3-space and a plane in a right line, a 3-space and a right line in a point, and two planes in a point. If the intersections are at an infinite distance the intersecting elements are said to be parallel, and if two 3-spaces are parallel all figures or volumes in one 3-space are at equal distances from the other 3-space. In the case of planes there are two kinds of parallelism, and parallel planes are either completely or incompletely parallel according as they are in the same or different 3-spaces, or as their intersection at infinity is a right line or a point.

To a given right line at a given point one can erect in a plane but one perpendicular, while in a 3-space one can erect an infinite number of perpendiculars, forming together a perpendicular plane, and in hyperspace an infinite number of perpendicular planes forming together a 3-space perpendicular to the given right line. A 3-space can also be perpendicular to a plane or to another 3-space. Planes may be perpendicular in two ways, incompletely or completely perpendicular, according as they are in the same 3-space or not; in the latter case every right line of either

2 non-intersecting right lines or by a plane and one point not in it.

Just as portions of our space are bounded by surfaces, plane or curved, so portions of hyperspace are bounded by hypersurfaces (three-dimensional), i. e.,



Graham Denby Fitch.

Lieut.-Col. Graham Denby Fitch, the winner of the Fourth-Dimension Competition, is a son of Henry Satterlee Fitch (captain of volunteers during the civil war; served on Gen. Sherman's staff), a grandson of Dr. Graham Newell Fitch (U. S. Senator from Indiana, colonel 46th Indiana volunteers during the civil war), and a nephew of Col. Charles Denby (U. S. Minister Plenipotentiary to China for over twelve years). He was born in 1860 in Chicago, where his father was then United States district attorney. He spent nearly six years at school in Germany and France, returning to the United States in 1876. President Hayes gave him an appointment to the U. S. Military Academy in 1878. He was graduated in 1882 among the "distinguished cadets," standing No. 4 in his class. Lieut. Fitch after one year's service with the Fifth Artillery at Fort Wadsworth, N. Y., was transferred to the Corps of Engineers. After completing the post-graduate course at the Engineer School at Willets Point, N. Y., in 1885, he for the next nine years was on duty in different parts of the country as assistant to various engineer officers in charge of river and harbor improvements. In 1895 Capt. Fitch was assigned to duty at Memphis in charge of Mississippi River improvements from Cairo to the mouth of White River. In 1897 he was on duty again at Willets Point, N. Y., commanding Company C, Battalion of Engineers, and as instructor of military engineering at the Engineer School. During the war with Spain he served throughout the Cuban campaign, first in command of his company, later as major of volunteers on Gen. Lawton's staff, and then in command of the Battalion of Engineers. Since the war he has been stationed in succession at St. Louis as secretary of the Missouri River Commission, at Oswego in charge of the harbor improvements on Lake Ontario, and at Little Rock in charge of the improvement of the Arkansas, White, Black, and other rivers. In 1906 Major Fitch was assigned to duty at Duluth, where he now is, in charge of the harbor improvements on Lake Superior. He was promoted to a lieutenant-colonelcy in 1908. Col. Fitch has written, aside from his official reports, a technical engineering paper on "Lock and Dam Construction on the Upper White River, Arkansas," first printed by the War Department in 1904, and copied somewhat condensed in the issue of Engineering Contracting for May 6th, 1908. He has translated for the Military Information Division of the General Staff various papers on military topics from the German, French, and Italian. Col. Fitch is a member of the American Society of Civil Engineers, also of the University Club of New York city.

flat or curved 3-spaces. Hyperspace contains not only an infinite number of flat 3-spaces like ours but also an infinite number of curved 3-spaces or hypersurfaces of different types. A hypersphere, for instance, is a closed hypersurface all the points of which are equally distant from its center. Five points not in the same 3-space determine it, just as 4 points not in the same plane determine a sphere, and 3 points not in the same straight line a circle. All of its plane intersections are circles, all of its space intersections are spheres. A hypersphere of radius R passing through our space would appear as a sphere with a radius gradually increasing from zero to R and then gradually decreasing from R to zero.

While in our space there are but 5 regular polyhedrons (solids bounded by equal regular polygons), namely, the tetrahedron, cube, octahedron, dodecahedron, and icosahedron; in hyperspace there are 6 regular hyper-solids (cells), bounded by equal regular polyhedrons. These are C^5 (bounded by 5 tetrahedrons), C^6 (by 8 cubes), C^7 (by 16 tetrahedrons), C^8 (by 24 octahedrons), C^{10} (by 120 dodecahedrons), and C^{20} (by 600 tetrahedrons). All of them have been exhaustively studied by mathematicians, and models of their projections on our space have been constructed. Of these, C^6 (or the hyper-cube) is the simplest, because, though with more bounding solids than C^5 , it is right-angled throughout, and therefore the standard form for measuring hyperspace. It is generated by a cube moving in the direction perpendicular to our space for a distance equal to one of its sides. In Fig. 1 where all dotted lines are supposed to be in hyperspace the initial cube is symbolically represented by $ABCDEF G H$ and the final cube by $A'B'C'D'E'F'G'H'$, the direction AA' being supposed perpendicular to our space. Projecting the edges of a hypercube on our space we get a network model of which Fig. 2 is a plane projection. The eight bounding cubes are represented in the model by the following projections: (1, 2, 3, 4, 5, 6, 7, 8), (5, 6, 7, 8, 9, 10, 11, 12), (9, 10, 11, 12, 13, 14, 15, 16), (13, 14, 15, 16, 1, 2, 3, 4), (1, 5, 9, 13, 2, 6, 10, 14), (2, 6, 10, 14, 3, 7, 11, 15), (3, 7, 11, 15, 4, 8, 12, 16), (4, 8, 12, 16, 5, 9, 13, 1).

	In Initial Cube.	Generated.	In Final Cube.	In Hyper Cube.
Corners	8	..	8	16
Edges	12	8	12	32
Faces (squares)	6	12	6	24
Cubes	1	6	1	8

Each corner is common to 4 mutually perpendicular edges, to 6 faces and to 4 cubes; each edge is common to 3 faces and 3 cubes; and each face is common to 2 cubes. Every cube therefore has one face in common with 6 of the 7 others. We must conceive of the hypercube as composed of cubes starting from squares parallel to the faces of the cube and of these cubes all that exist in our space are the parallel squares from which they start.

In a plane the only kind of rotation possible is that about a point, in 3-space rotation can take place about
(Concluded on page 15.)

Fatty Lubricants.

There are cases in which natural fats, with or without admixture, still form the best lubricants. A good lubricant for swiftly moving and lightly loaded parts of machines is made of equal weights of graphite and tallow, very thoroughly mixed. An excellent lubricant for piston rods is made by melting together 40

ored, homogeneous, free from acids, alkalies, resins, and mechanical impurities, and should not contain more than 2 per cent of water or more than 10 per cent of lime soap, an ingredient which is added to some of these mixtures.

Traube has devised a very simple process for puri-

THE COTTON INDUSTRY OF THE UNITED STATES.

The Bureau of the Census is constantly issuing bulletins which give the facts relating to various industries without waiting until the decade has been finished. Thus the figures for textile manufactures are for the year 1905. The figures relating to manufactures of cotton are most interesting and we have given

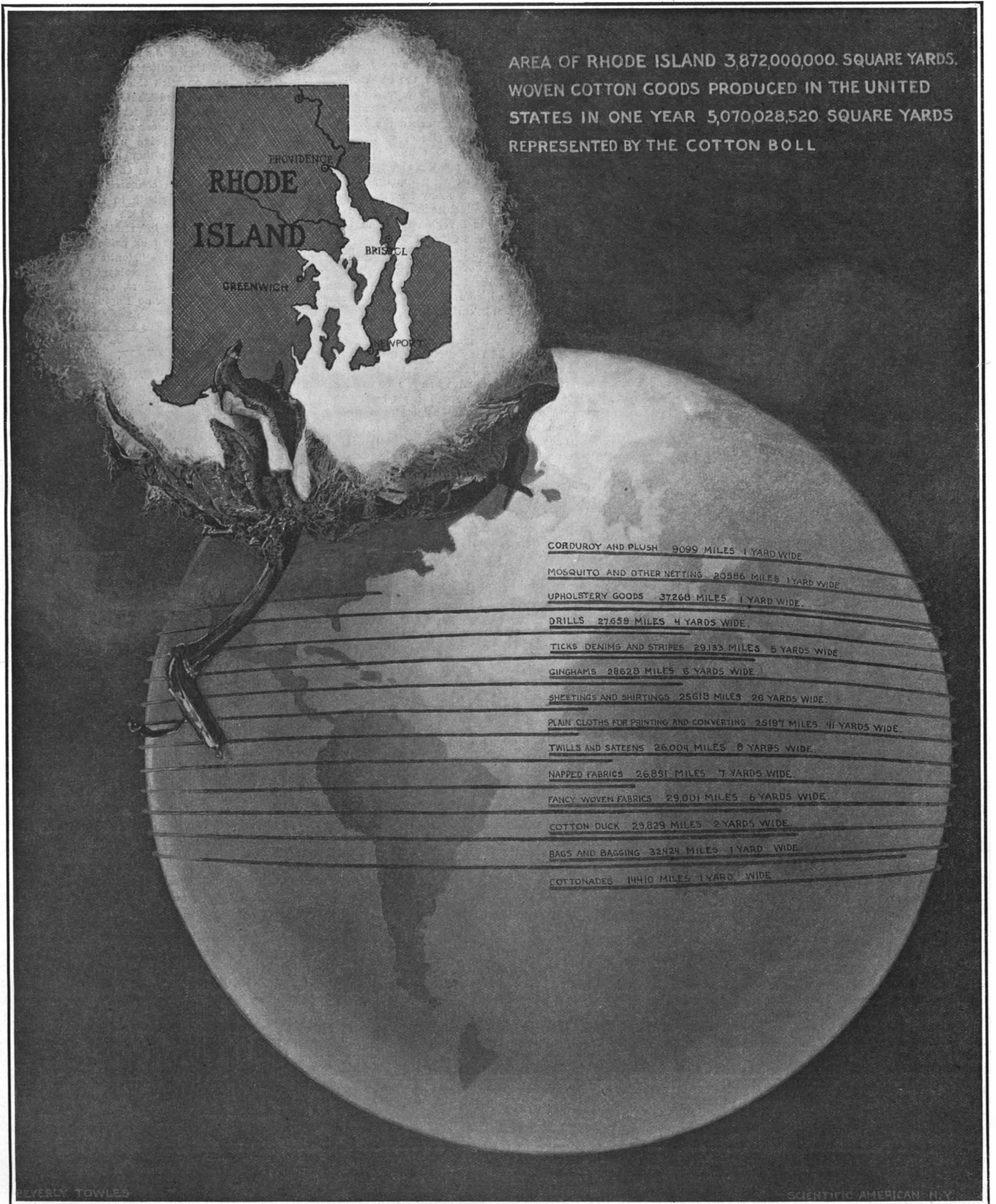

Copyright 1909 by Munn & Co.

THE MAGNITUDE OF THE COTTON INDUSTRY. FROM COTTON BOLL TO FINISHED PRODUCT.

parts of neutral wool grease and 10 parts of ceresin (a derivative of ozokerite or mineral wax), and adding to the hot mixture 25 parts of pure mineral oil and 25 parts of graphite. Good results have recently been obtained with "calypsol," which is alleged to be a Canadian vegetable fat, free from acid and of high melting point. A solid lubricant should be light col-

or, homogeneous, free from acids, alkalies, resins, and mechanical impurities, and should not contain more than 2 per cent of water or more than 10 per cent of lime soap, an ingredient which is added to some of these mixtures. The process consists, essentially, in adding to the crude spirit a strong solution of ammonium carbonate or ammonium sulphate. The mixture separates into two parts, and if the temperature and the concentration of the ammonium salt are properly chosen, all the impurities are accumulated in the upper portion.

some of them in graphical form. The annual cotton crop (year ending June 30th, 1905) was 13,565,885 bales, representing a gross weight of 6,994,281,731 pounds. Of this amount 4,304,848,903 pounds was exported. In the same period only 60,508,548 pounds of cotton was imported.

The manufactured articles made in the year 1905 are

shown in our comparison. The area of Rhode Island is 3,872,000,000 square yards, while the woven cotton goods produced in the United States during the year was 5,070,028,520 square yards. This is represented by a cotton boll reproduced in scale with the map of Rhode Island. An actual cotton boll was used as the basis of the drawing. The figures can be analyzed as follows:

Kind.	Square yards.	Value.
Aggregate value		\$442,451,218
Woven goods, total	5,070,028,520	320,382,367
Plain cloths for printing or converting, total	1,818,216,172	80,311,612
Not finer than No. 28 warp	812,249,764	32,945,694
Finer than No. 28 warp	1,005,966,408	47,365,918
Brown or bleached sheetings and shirtings	1,172,309,182	61,253,376
Ginghams	302,316,132	22,471,867
Ticks, denims, and stripes	256,375,486	23,797,578
Drills	194,735,303	12,596,063
Twills and sateens	366,142,513	23,701,305
Cottonades	25,362,346	2,998,971
Napped fabrics	330,808,140	26,108,315
Fancy woven fabrics	306,254,685	28,486,342
Corduroy, cotton velvet, and plush	16,014,556	4,790,573
Duck, total	122,601,212	17,005,982
Sail	9,586,519	1,540,745
Other	113,014,693	15,465,237
Bags and bagging	57,067,663	3,953,732
Mosquito and other netting	36,232,918	794,953
Upholstery goods, total	65,592,212	12,111,698
Tapestries (piece goods and curtains)	9,605,006	4,242,506
Lace and lace curtains	53,511,222	7,208,211
Chenille curtains	268,168	93,196
Other, including covers	2,207,816	567,785
	Pounds.	
Yarns for sale	364,472,753	79,885,387
Sewing cotton	17,163,741	15,043,043
Twine	6,676,573	1,282,947
Tape and webbing		49,546
Batting and wadding	10,165,850	1,173,343
Waste for sale	247,335,102	10,049,037
Other products of cotton		2,605,801
All other products		11,979,747

In our engraving the circles around the earth represent the distance covered by the different cotton goods manufactured in the United States in the year specified. The quantity of some of the goods manufactured is so great that it was necessary to make the strips many yards wide.

Some idea of the magnitude of the industry may be obtained when it is stated that there were in the same year 23,155,613 spindles in cotton mills.

The capital of the 1,077 establishments was \$605,100,164. There were 310,458 wage earners and 6,738 salaried officials, clerks, etc. The total amount of wages paid was \$94,377,696, and \$9,911,767 for salaries; the cost of the materials used was \$282,047,648, and our table shows products worth \$442,451,218. This is indeed a vast industry, and one which has enabled us to successfully compete in the markets of the world.

Tetanus and the Glorious Fourth.

BY JOHN B. HUBER, A.M., M.D.

A wholesome tendency is now making for the elimination of such features of Independence Day as have especially endangered the lives of the young—and this while in no wise suppressive of normal enthusiasm. We need not go the length of some who have rather hysterically termed this holiday the Bloody Fourth, with its "annual holocaust of carnage." Nevertheless, it is certainly the part of wisdom and of humanity to plead for less detonating celebrations than have obtained in the past. In Continental countries such occasions are commemorated quite adequately, and just as heartily as with us, by means of fêtes and other "rational ceremonies." For adult patriotism oratorical explosions suffice; but these, for reasons we need not probe, are not sufficiently satisfying to the youth. In the legitimate interests of boyhood, some reconciliation of patriotism and prophylaxis is essential.

The citizen is probably unfamiliar with the extent to which children have died from "Independence Day tetanus," or lockjaw, than which there can be no more painful or cruel death; nor is it generally realized how many other children have survived wounds received on that day, without having contracted tetanus, who have nevertheless been dreadfully maimed or disfigured for life. It is related that these celebrations of the last six years show for the whole country a grand total of 29,296 killed and wounded. The American Medical Association has taken up the matter; and its Journal reports that in 1903 there were 415 cases of Fourth of July tetanus; in 1904, 105 cases; in 1905, 104 cases; in 1906, 89 cases. In 1907 there were 55 recorded cases. These cases were brought about in more than sixty per cent by blank cartridges; in about sixteen per cent by giant fire-crackers; in about four per cent by cannon; in about five per cent by fire-arms; in about ten per cent from powder, etc. The decrease in casualties has thus been progressive since 1903. And Baltimore was, I believe, the pioneer in the agitation which is resulting so beneficently. In that community there is now an ordinance providing that "no person shall cast, throw, or fire any squib, rocket, cracker, torpedo, grenade, or other combustible fireworks or explosive preparation within the city"; nor may any such explosives be made in Baltimore. There were in consequence but ten accidents on last Independence Day. Philadelphia, saturated as it nowadays is with worthy and unassailable patriotism, was

able for the same day to produce a total of 432 killed and injured. Denver, Detroit, Minneapolis, St. Paul, Louisville, and Omaha now have ordinances similar to Baltimore's; with the result that no life was sacrificed in any of these cities. In New York, it would seem, sundry among our municipal fathers (with interests on the side) have determined that the ideals upon which our republic were founded shall not die for want of fireworks; for they will not endure that we shall be surpassed in patriotism.

How can we prevent tetanus fatalities arising out of Fourth of July celebrations? The tetanus bacillus is anaerobic; and to this property is certainly due the comparative and the fortunate rarity of the disease—despite the fact that the bacillus is very prevalent in many localities. This germ thrives only in wounds closed, and thus devoid of oxygen; whence the term "anaerobic." It rarely traverses the site of an injury—rarely enters the blood and lymph channels. The toxins or poisons generated by it are the virulent factor. It has its habitat mostly in earth; sometimes in putrefying fluids and manure. In many localities, as in parts of Long Island, it is ubiquitous. Tetanus is said to be curiously endemic in a region from one to five miles in extent near Atlantic City, N. J.

The infection generally occurs through the introduction of impregnated dirt into wounds, sometimes very slight, wounds especially of the face, hands, and feet. Most cases, as we have noted, come about through the discharge of powder in blank cartridges, which consist, besides the powder, mainly of paper. Half the remaining cases are due to the giant fire-cracker (not the small kind). The wound may serve for the introduction of germs accidentally present on the skin—a phenomenon readily understood when we consider the normal state of the average small boy's hand.

There may be but a mere burn—something quite superficial; yet some part of a wound, however slight, may become at once impermeably sealed. The bacilli may thus secure an implantation in microscopic pockets or fissures. In puncture tetanus the germ may be introduced upon the instrument itself, as a dirty or rusty nail or the tine of a pitchfork. Blank cartridges may be made of germ-harboring material. Punctured, contused, or lacerated wounds are much more dangerous than such as are clean cut, as with a dagger or a sharp knife. Crushing injuries, deep lacerations, gunshot wounds, wounds beneath the skin, the fat, or the fascia, and especially where dirty clothing has been introduced into torn flesh, are most to be feared.

Obviously then, the toy pistol and the giant fire-cracker must be forbidden children. Practically no cases of tetanus have developed (at least I have not seen a report of any) from Roman candles, torpedoes, paper caps, small fire-crackers, or display pieces. In order that no undue fear may arise, we note that for the 89 cases of tetanus developed in 1906 there were 979 blank-cartridge wounds. Thus tetanus by no means follows as a matter of course from wounds incurred on Independence Day.

The symptoms of this dreadful disease may not manifest themselves until an incubation period of a fortnight has elapsed after the injury. Then may appear rigidity of the neck and jaws, difficulty in chewing and swallowing, chills, high fever, asphyxia, spasm of various muscles, rapid pulse, profuse sweating, opisthotonus—dreadful suffering.

Immediately a child sustains an injury of the nature we have considered, a physician is to be called, who will administer an immunizing dose of tetanus antitoxin. Such a timely dose will almost surely protect against the development of the symptoms; but its efficacy decreases with the time lost in administering it. Before the use of this serum, death followed in at least 80 per cent of tetanus cases. All health departments now have this antitoxin available for immediate use upon application. The Health Department at Albany has advised the health officers throughout New York State to apply to it for supplies, in order that they may be prepared to provide local practitioners without delay. Its Bulletin states: "An immunizing dose of antitoxin is an almost certain means of preventing tetanus infection and intoxication; so far as we know, no case of lockjaw has developed in this country among those who have received an immunizing dose of this serum." In any event, the secretion of the wound may during the incubation period be scrutinized by the microscopist for the possible presence of the tetanus bacillus; its absence after several examinations should greatly allay fear of the disease.

Retirement of Secretary Wilson.

James Wilson, Secretary of Agriculture, will retire from office in December, and will probably be succeeded by Charles F. Scott, at present Representative in Congress from the Second District of Kansas and chairman of the House Committee on Agriculture.

Mr. Wilson has realized his ambition of serving in the Cabinet for a longer continuous term than any other man. He entered the Cabinet in President McKinley's first term. He is now nearly seventy-four

years of age. To him are due many important improvements in the administration of the Department of Agriculture, and likewise many new lines of research, the results of which have aided farmers throughout the country.

The Death of Egbert P. Watson.

Mr. Egbert P. Watson, formerly a member of the editorial staff of the SCIENTIFIC AMERICAN, died at Elizabeth, N. J., at the age of seventy-four, on June 22nd, 1909. In his professional career as an editor and an engineer, Mr. Watson displayed a wide engineering knowledge and keen editorial judgment. After he severed his connection with this paper he founded a periodical of his own called The Mechanical Engineer, and continued its publication for sixteen years.

Mr. Watson was an engineer of the old school; that is, his engineering knowledge was acquired mostly by hard work in the shop, although he was an omnivorous reader and well versed in engineering literature. Long after he severed his connection with this journal he continued to contribute to its columns occasional engineering articles, which were distinguished by the sound and practical information that they conveyed. Mr. Watson always took pride in the fact that he drove the first bolt in the "Monitor," the civil war ironclad. He was a past vice-president of the National Association of Marine Engineers, and was for many years a member of the Marine Engineers' and Architects' Association.

Death of Orrin S. Wood.

Mr. Orrin S. Wood, well known in this country as a pioneer telegraph engineer, died at Turner, N. Y., on June 22nd, 1909, at the advanced age of 91 years. Mr. Wood had the distinction of superintending the construction of the first telegraph line between New York and Philadelphia in 1845, and of opening the first telegraph office in New York city at Hanover Street and Exchange Place. His interest in telegraphy antedates these achievements, however; for in 1844 he became an operator on the original telegraph line between Baltimore and Washington, after having studied telegraphy under S. F. B. Morse himself. Mr. Wood helped to build the Albany-Buffalo line and the telegraph line connecting Buffalo, Niagara Falls, Toronto, Montreal, and Quebec, besides constructing a telegraph system northwest of Chicago, which now forms part of the Western Union lines.

\$100 Prize for a Fire Escape.

At the National Industrial Exposition to be held in Toronto, Canada, from August 28th to September 14th, fire escapes are to be exhibited under the auspices of the Commercial Traders' Association of Canada. The association will give a prize of One Hundred Dollars to the inventor of the best fire escape. The selection will be made by the Ontario government, and in all probability the successful fire escape will be placed in many hotels in the Province of Ontario. The conditions of the contest may be obtained by addressing the Commercial Traders' Association of Canada, Toronto, Canada.

The Current Supplement.

The wonderful results obtained by the great masters of the art of piano playing can also be obtained to a certain extent by mechanical means in the modern piano player. Mr. John F. Kelly describes in the current SUPPLEMENT, No. 1748, the construction of these piano players, and shows how they have evolved from crude forms. Mr. John A. Mathews' paper on the new automobile steels is concluded. Among the numerous fads and fancies of the house furnisher of to-day, none is more quaint and interesting than the decorative use of the vari-colored bottles and flasks of many shapes and sizes that are relics of one of the oldest enterprises of this country. Ada Walker Camehl writes interestingly on this subject, and illustrates her article with pictures of curious bottles. The manufacture of nitrates from the atmosphere by means of the Birkeland-Eyde process is set forth by Sam Eyde. What a very small telescope will do is excellently described by Arthur Mee. Prof. C. Doelter writes on the influence of radium and ultra-violet rays upon the color of minerals. F. Hartmann contributes a good technological article on gilding.

During Mr. Andrew Carnegie's recent visit to Paris he was given an official reception at the University. It will be remembered that Mr. Carnegie donated a considerable sum to this institution so as to enable it to found a special laboratory for researches upon radium, to be carried on by Mme. Curie. During the reception Mr. Carnegie was presented with a medal commemorating his generosity to the University. In a conversation with President Fallières, he made known his intention of establishing an institution such as exists in America and England for rewarding heroic actions, and proposes to donate a million dollars for this purpose.

THE "MICHIGAN"—OUR FIRST "DREADNOUGHT."

The first "Dreadnought" to be completed for the United States navy is the "Michigan," which, with her sister, the "South Carolina," was authorized by Congress March 3rd, 1905. In the act of authorization the displacement of these ships was placed at 16,000 tons, which is that of the "Connecticut" and "Kansas" class. It was intended to provide these vessels with the same armor and armament as the ships of those classes, but before the construction was far advanced, it was decided to give them as much as possible of the "Dreadnought" characteristics, and the plans were changed accordingly.

The "Michigan," which was built by the New York Ship Building Company, Camden, N. J., was recently taken to the government course at Rockland, Me., for her standardization trials; and on June 9th, during five runs at maximum speed, she averaged just under 19 knots per hour, or to be exact 18.976 knots. On the fastest run over the measured mile she reached a speed of 20.01 knots.

The accompanying photograph was taken of this fine vessel when she was running at a speed of over 19 knots; and it serves to show very clearly the special characteristics of the ship, notably her two lattice-work, fire-control masts and her main battery of eight 12-inch guns carried in four turrets.

The "Michigan" is a "Dreadnought" in everything except size and speed, the displacement being from 3,000 to 4,000 tons less than that of the typical "Dread-

the conning tower and two smokestacks, the two military masts, and two boat derricks, placed abreast of the smokestacks. Within the superstructure and carried on the spar deck is a battery of ten 3-inch guns for torpedo defense; and twelve other 3-inch pieces are mounted on the superstructure bridges and elsewhere on points of vantage throughout the ship.

Abaft of the superstructure are the remaining two 12-inch gun turrets, one mounted on the main deck at a command of about 17½ feet above the sea, and ahead of this another turret with its guns carrying at a height of 25½ feet above the water. This disposition of main armament gives a broadside of eight 12-inch and a fore-and-aft fire of four 12-inch.

The armor plan of the "Michigan" shows a water-line belt 8 feet wide, tapering amidships from 11 inches in thickness at the top to 9 inches at the bottom. The belt reduces gradually to a thickness of 4 inches at the ends of the ship. Above the main belt, and extending from the forward to the after barrette, is another belt of armor 10 inches thick at its lower edge, 8 inches thick at its upper edge, and 8 feet in width. The barbets for the 12-inch turrets are from 10 to 8 inches in thickness. The turrets themselves have 12 inches of armor on the sloping portplate and 8 inches on the sides and at the back. The protective deck is 1½ inches in thickness amidship and forward, and 3 inches in thickness in its after portion. The big guns are manipulated by electric power, as are also the ammunition hoists. The tor-

be used as a small captive balloon for military purposes. It is also possible to transform a section quickly into a small dirigible by installing a little motor in its car. For this purpose the section is provided with a blower for distending the balloon and with vertical and horizontal rudders. Two sections without frames may be combined to form a larger non-rigid airship. The car of the entire airship contains as many sections as the balloon, so that each partial balloon possesses its own car, with the exception that a special division of the car is reserved for the machinery. In the estimation of the inventor the sections can be put together by a balloon corps in two hours.

Saponification and Pancreatic Juice.

In making soap and candles the natural fats are saponified, or resolved into their component parts, fatty acids and glycerin, by various methods, including the action of alkalies, lime, sulphuric acid, superheated steam, etc.

Haller has devised a method of effecting saponification by means of methyl or ethyl alcohol, and Conheim and Nicloux have suggested a biological method based on the employment of a diastase which occurs in castor oil beans.

Baur has recently proposed the use of the pancreas of animals, which contains a soluble ferment capable of resolving fat into fatty acid and glycerin in from one to four days. This method has been successfully tested with beef suet and with coconut, cotton-seed,

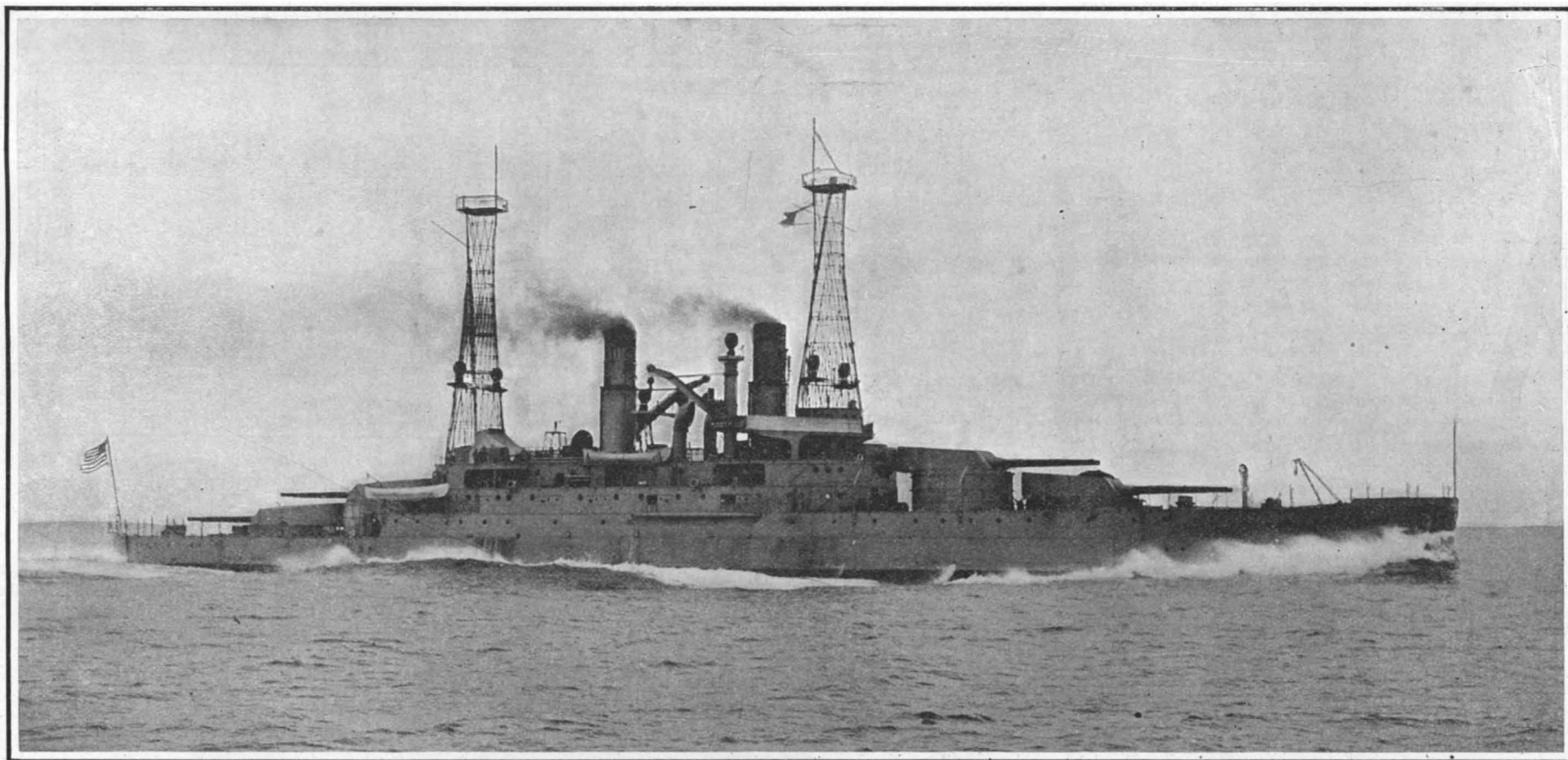

Copyright 1909 by N. L. Stebbins.

Displacement, 16,000 tons. **Speed,** 18.97 knots. **Coal supply,** 2,200 tons. **Armor:** Belt, 11 inches; side armor, 10 to 8 inches; turrets, 12 to 8 inches; deck, 1½ to 3 inches. **Armament:** Eight 45-caliber 12-inch; twenty-two 3-inch. **Torpedo tubes,** two submerged 21-inch. **Complement,** 869.

OUR FIRST "DREADNOUGHT," THE "MICHIGAN," MAKING 19 KNOTS ON HER TRIAL TRIP. SISTER SHIP "SOUTH CAROLINA."

nought" of to-day, and her speed about two knots less. In respect of protection and armament, however, she is fully qualified to lie in line of battle with the heaviest ships of the "Dreadnought" type. Although she carries but eight 12-inch guns as against ten carried by the British ships, the position of her turrets, all of which are on the center line, enables her to deliver the same weight of fire on either broadside, namely, eight 12-inch guns. Speaking of the penalties paid by the "Michigan" on account of her small displacement, it should be mentioned that it was necessary to cut down her freeboard aft and lower the after two turrets eight feet below the positions at which they are carried on our later "Dreadnoughts" of larger displacement.

The "Michigan" is 450 feet long, between perpendiculars, 452 feet 9 inches over all, 80 feet 2½ inches in breadth at the water line, and on a mean draft of 24 feet 6 inches has a displacement of 16,000 tons. Her full load displacement is 17,617 tons. The speed called for by the contract is 18.5 knots, which, as we have seen above, was exceeded. She is driven by twin-screw, reciprocating engines of 16,500 horse-power, and she has a maximum bunker capacity of 2,200 tons.

The armament consists of eight 45-caliber 12-inch guns mounted in four turrets. The foremost pair are 25½ feet above the water. Back of these are two guns in a single turret, which fire, above the roof of the forward turret and are carried at a height of 33½ feet above the water. The superstructure occupies about one-third of the vessel's length amidship. It contains

pedo equipment consists of two submerged torpedo tubes for the discharge of the new 21-inch turbine-driven torpedo.

At the present time we have completed or under construction for the United States navy eight "Dreadnoughts": The "Michigan" and "South Carolina," of 16,000 tons, carrying eight 12-inch guns; the "Delaware" and "North Dakota," of 20,000 tons, carrying ten 12-inch guns; the "Florida" and "Utah," of 21,325 tons, mounting ten 12-inch guns; and the "Wyoming" and "Oklahoma," of 26,000 tons, each mounting twelve 12-inch guns.

A Dirigible Balloon Made in Sections.

A German engineer named Weissenburger has constructed a model of a dirigible balloon which can easily be taken apart for transportation. This possibility is of great value, as often the transportation of the balloon is made necessary by a premature landing or other cause. The model, which is about 13 feet long, consists of eight sections, each of which is in the form of a cylinder with hemispherical ends, and can be collapsed like an umbrella by turning a handle. The convexities of both ends of the section are directed forward, so that when the sections are put together, the rear end of one closely embraces the forward end of the next. The sections are made entirely alike, so that a damaged section can be replaced by a reserve section. Each section possesses its independent gas bag, air ballonet, frame, and points of attachment to the car and steering apparatus, and each section can

maize, and palm oils. This process, if universally adopted in all countries, would require 12,000 tons of pancreas annually. The abattoirs of the world furnish about two-thirds of this quantity, or 8,400 tons. In comparison with the employment of the castor bean ferment, the pancreatic method effects a more complete saponification which compensates for its greater cost.

The annual summary of shipbuilding just issued by Lloyd's Register shows that the total output of the world during 1908 (exclusive of warships) appears to have been 1,833,286 tons (1,706,179 steam, 127,107 sail). According to the latest returns received by Lloyd's Register, the tonnage of all nationalities totally lost, broken up, etc., during the twelve months amounts to about 794,000 tons (557,000 steam, 237,000 sail). The net increase of the world's mercantile tonnage at the end of 1908 is thus about 1,039,000 tons. Sailing tonnage has been reduced by 110,000 tons, while steam tonnage has increased by 1,149,000 tons. Of the tonnage launched during 1908, the United Kingdom has acquired over 30¼ per cent. Of the total merchant tonnage output of the world during 1908, 50¼ per cent was launched in the United Kingdom; but, if only sea-going steel steamers of 3,000 tons gross and upward be taken into account—thus excluding vessels trading on the North American Lakes—out of the total of 179 such steamers of 1,050,741 tons launched in the world, over 63 1-3 per cent of the tonnage was launched in the United Kingdom.

A MUSEUM TO ILLUSTRATE THE DEVELOPMENT OF MATHEMATICS.

BY HERBERT T. WADE.

As an interesting and important part of the study of the history of mathematics, it is essential to consider

astronomy; and just as soon as trigonometry was developed to a point where it was available for practical use, there was need of instruments for the measurement of angles and for realizing or imitating the relative movements of the celestial bodies. Now, for

staff itself, a rough angular measurement could be made. Various improvements gave the fore staff and the back staff, but the first really serviceable instrument was the quadrant, which was the ancestor of our modern and indispensable sextant. A good specimen of a quadrant of Tyrolean workmanship, and dating back to about 1600, is contained in the collection and is here illustrated. The alidade or movable bar carries two small transverse pieces pierced with sight holes, and is so pivoted that it can be moved over the graduated quarter of a circle, which gives to the instrument its name. The quadrant could be used for measuring both vertical and horizontal angles, and naturally lent itself to determining the elevation of the heavenly bodies in astronomy and navigation, so that by the middle of the sixteenth century it was accepted as a necessary nautical instrument, as well as used on land wherever trigonometry was applied to surveying. The Italian textbook, "L'Uso della Squadra Mobile Opera di Ottavio Falii. In Trento, MDCCLII," a page of which is shown in the illustration, gives the actual directions for the use of the quadrant in measuring the height of the tower by the familiar trigonometrical principles involving the measurement of linear distances, here by pacing, and the determination of angles.

Practically contemporary with the quadrant was the astrolabe, where the entire circle was employed, and where by the use of an alidade and a divided circle or limb the angular distance between two stars could be determined, leading to the deduction of the motions of the planets by the astronomers and astrologers of the middle ages. The use of the instrument is indi-



A medieval astronomer using an astrolabe.

Reproduction of a plate from an 18th century work.



Astrolabes made by Bernardinus Sabeus of Padua (Italy) 1558 and by an unknown Italian craftsman between 1450 and 1525.

the various means that have been employed in the application of this science to every-day life. From the times of Babylon to the present day, there has been an interesting succession of ingenious and useful devices and instruments, of a very practical nature, which when considered together are remarkably striking in illustrating the development of what is usually regarded only as a most abstract science. Such a collection has been assembled by Prof. David Eugene Smith of Teachers' College, Columbia University, and recently it has been on exhibition in the Educational Museum of that institution. Containing as it does many objects of great interest to the archaeologist, metrologist, surveyor, and engineer, yet it is in its relation to the historical development of the science of mathematics, and its great influence in bringing out this development to the student, that the exhibition possesses its highest value. With this end in view, Prof. Smith has accumulated a collection of mathematical instruments, weights and measures, sun dials, and other devices for time measure, mathematical manuscripts, early printed works, an extensive collection of portraits and autographs of prominent mathematicians, and curios gathered from many corners of the world, some of the most interesting and significant of which have been specially photographed for the SCIENTIFIC AMERICAN.

One of the most important and fundamental applications of mathematics has been to surveying and

measuring angles in the early times a device known as a cross staff was used, where a movable transverse piece could be adjusted along the length of a wooden

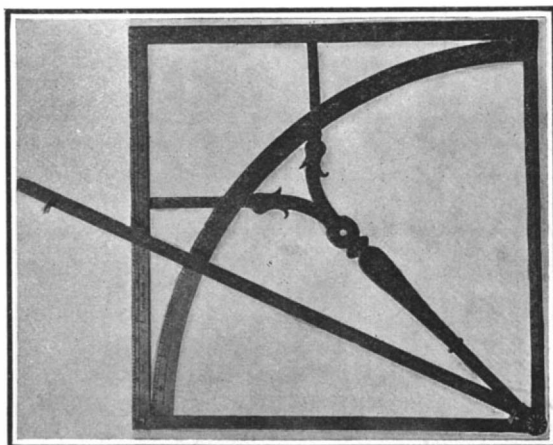

Quadrant of Tyrolean workmanship dating from about 1600.

This was the common trigonometric instrument of medieval times and its use is shown in the accompanying illustration.

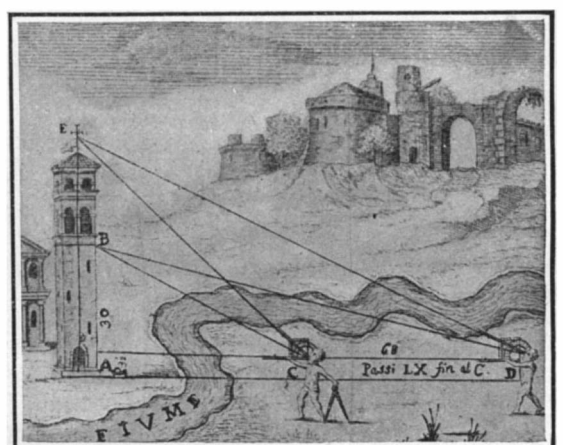

Using the quadrant to measure the altitude of an inaccessible tower.

Reproduction of a plate from an 18th century treatise on the quadrant.

staff, so that by sighting from one of its extremities over the end of the cross piece, and then laying off the angle thus formed by the line of sight with the

cated by the accompanying reproduction of a page from an eighteenth century scientific treatise, while (Continued on page 15.)

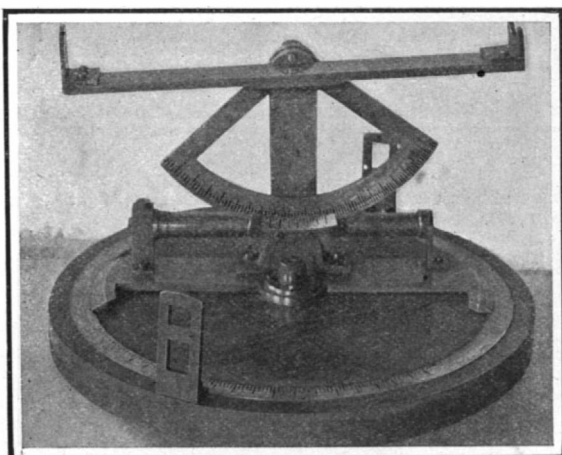

Early 19th century German surveying instrument. Made by Wiskemann of Meiringen.

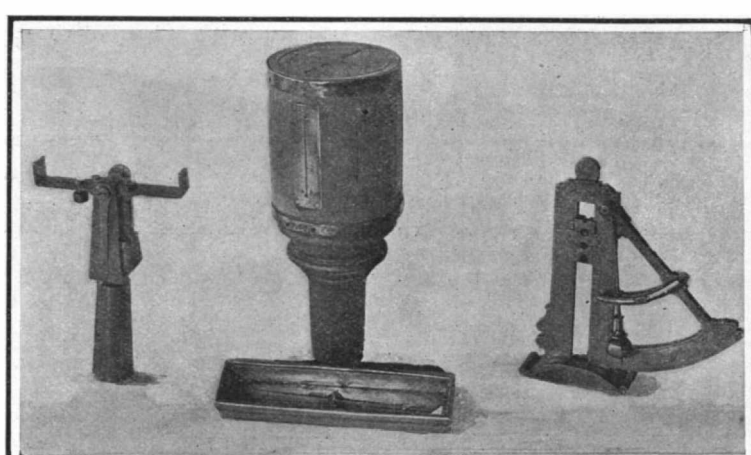

Early surveying instruments.

Surveying level (German).

Italian squadra. Cannon level.

Surveyor's compass.



Celestial sphere of Italian workmanship dating from the 16th century.

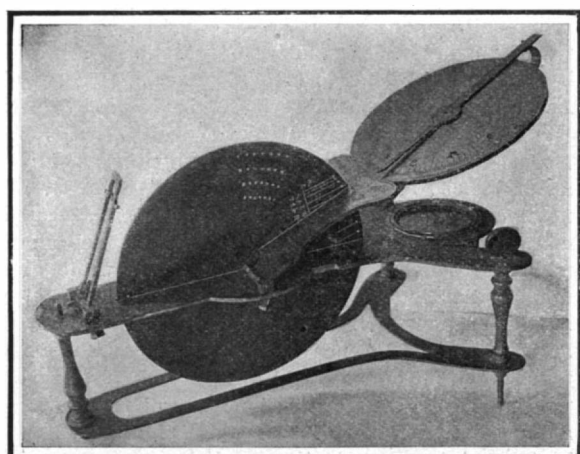

Chinese sun dial of the 18th century from Peking.

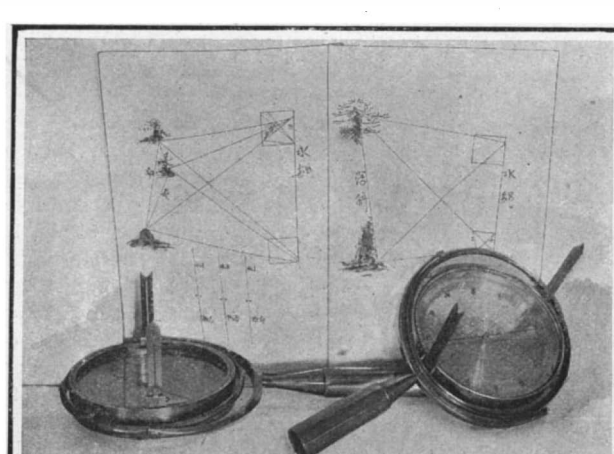

Japanese surveying instruments of the early 19th century and Japanese surveying textbook.

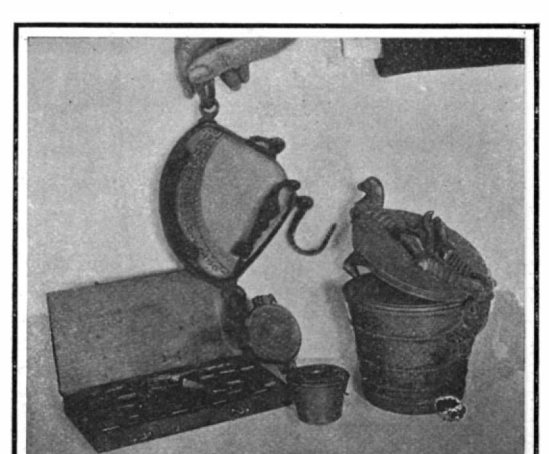

Bavarian scales of the 18th century and various sets of weights.

A HUGE FILTERED WATER RESERVOIR FOR LONDON.
BY THE ENGLISH CORRESPONDENT OF THE SCIENTIFIC AMERICAN.

The maintenance of an adequate water supply for the constantly expanding English metropolis is a problem of supreme importance and one of no little difficulty. The main sources of supply are the River Thames at a point well above tidewater, the river Lea, and wells sunk into the solid chalk. Recently the facilities for supplying water have been appreciably improved by the erection at Honor Oak, in the southeastern suburban area, of a huge covered-in reservoir, the largest of its type in the world, for storing filtered water, the capacity of which when full is 58,000,000 gallons.

The necessity of a new reservoir was recognized as far back as the early nineties. Not until 1898 was work begun by the local water supply company. In that year a large brick-making plant was erected on soil eminently suited to brick making. The result of this development was rendered obvious during actual constructional work, since the brick material was available on the spot and delays, as well as cost of transport, were avoided. The saving thus effected may be readily realized when it is considered that upward of 16,000,000 bricks were utilized in the building of the reservoir. At the same time the brick plant offered an economical solution of the problem of disposing of the greater part of the excavated material for the foundation of the reservoir, etc., which material aggregated 173,000 cubic yards.

After all the water-supply companies of London were subsequently consolidated into the Metropolitan Water Board, the undertaking was rapidly completed. The undertaking was designed and carried out under the supervision of Mr. J. W. Restler, M.Inst.C.E., the deputy engineer-in-chief of the Metropolitan Water Board, to whose courtesy we are indebted for the accompanying illustrations and for much information.

It is the primary purpose of this reservoir to maintain a low-pressure supply throughout the metropolitan area on the southeastern side of the Thames. But if occasion should demand, it can be dispatched by means of mains under the river to the northern territory. The maximum water level of the reservoir is approximately 144 feet above ordnance datum. The depth of water throughout the greater part of the structure is about 21½ feet, but in a part of the north-eastern section it reaches a depth of 34 feet.

The reservoir is divided at right angles into four sections, each of which is independent of the others, so that any one may be emptied when desired for cleaning, without interfering with the service, suitable appliances being provided for diverting the water from the supply main into one or other sections. The building is erected on a natural clay formation, the flooring being of solid concrete forming inverted arches, crossing one another at right angles. From the apex of each groining, spring piers of solid brick-

work of cruciform section to carry a brick roof, comprising a series of segmental arches running parallel the whole length of the structure, with segmental jack arches at right angles carried from pier to pier throughout the series. The reservoir is therefore divided into a series of cells 21 feet 6 inches square from center to center of the brick piers, the thickness of the brickwork of the latter being 18 inches with a width across of 4½ feet. Down the centers of the inverted arched floor extend drainage channels communicating in a well near the intersection of the reservoir into the four sections, while at the actual point of

places where the pressure is the greatest the buttresses for the retaining wall are carried back to the fourth bay from its face. Around the outside of these retaining walls a puddled clay wall 3 feet thick is provided, the puddle being taken well down into the London clay and rendered thoroughly water-tight by careful tamping. This wall is carried up to, and connected with, the layer of clay extending over the entire roof of the structure. On the northern and parts of the eastern and western portions, where the top of the reservoir projects above the natural surface of the ground, an earthen embankment is provided, which embankment is composed of alternate layers of earth and burnt ballast of 20 inches and 4 inches thickness respectively, and with a slope ranging from 2½ to 3½ to 1.

The reservoir measures 824 feet in length between the walls, and has a maximum width of 587 feet. The total area covered approximates 14¼ acres, the actual water area being a little over 10 acres. The supply is drawn from the 42-inch main, which brings the filtered water from the pumping station at Hampton, some 17 miles distant. The outlet pipe is of the same diameter. The supply can be augmented from a deep-well pumping station, which has been erected on the site, and from which a large quantity of water can be drawn. This well has a diameter of 11 feet and is sunk for a depth of 300 feet, the lower half of which is through chalk. Headings have been driven into the latter in all directions to a total length of 3,400 feet. The water is raised by two sets of three-crank vertical triple-expansion engines coupled to deep-well pumps having cylinders of 18 inches bore by a stroke of 5 feet. The water

thus obtained, in addition to being discharged into the adjacent reservoir, can be delivered into mains feeding two other reservoirs in the vicinity. The total cost of the enterprise has been \$1,200,000.

Another Substitute for India Rubber.

A. G. Inrig has patented in Great Britain and Germany a new process for making a substitute for India rubber. The materials used are animal refuse capable of yielding gelatin, oils, sulphur, chromates, and sodium stannate, the addition of the last-named salt being the distinguishing feature of the process. The proportions recommended are animal refuse 100 parts, water 50 parts, oil 20 to 60 parts. These ingredients are stirred together for about an hour and then 1 per cent of potassium bichromate and 1 per cent of sodium stannate are added. The mixture is then heated to about 212 deg. F. and kept at this temperature about 5 minutes or until the previously liquid mass becomes pasty, in which condition it is poured into molds. A harder and tougher mass is made by adding 20 per cent of oil, 1 per cent of sodium stannate, 1 per cent of potassium bichromate, and 5 to 10 per cent of sulphur, and heating the mixture to 257 deg. F.

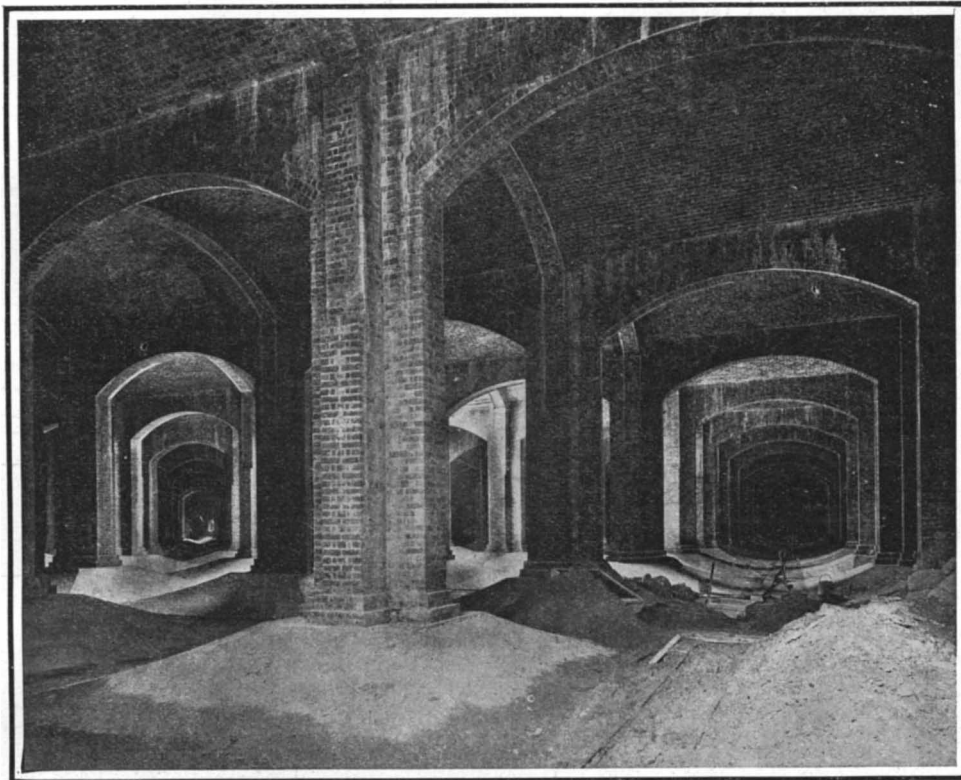

Interior, showing principle of dividing the reservoir into bays 21½ feet square.

intersection of the division walls is a circular valve chamber 24 feet in diameter extending from the bottom to the roof of the building, and into which lead the mains for supply, intercommunication with the four sections, and draw-off, these pipes being of 42 inches diameter and fitted with 36-inch valves operated from a valve house above.

In addition to the brickwork for the arched roofing, there is a 6-inch outer covering of concrete finished with clean cement, upon which is distributed a thick layer of clay and 6 inches of mold originally cleared from the site, so as to present a flat, level top surface. At frequent intervals 6-inch air pipes are distributed over the bays for ventilation and admission and escape of air during the respective processes of emptying and filling the reservoir.

The two division walls which run at right angles and divide the reservoir into four sections are cambered back to back with the intervening space filled with concrete. The outer walls are of concrete, with brick lining, ample precautions having been taken to bond the two thoroughly together. The thickness of the retaining walls varies from 16 feet to 6 feet at the base, and each bay is provided with a buttress reaching in most cases to the first pier. In those

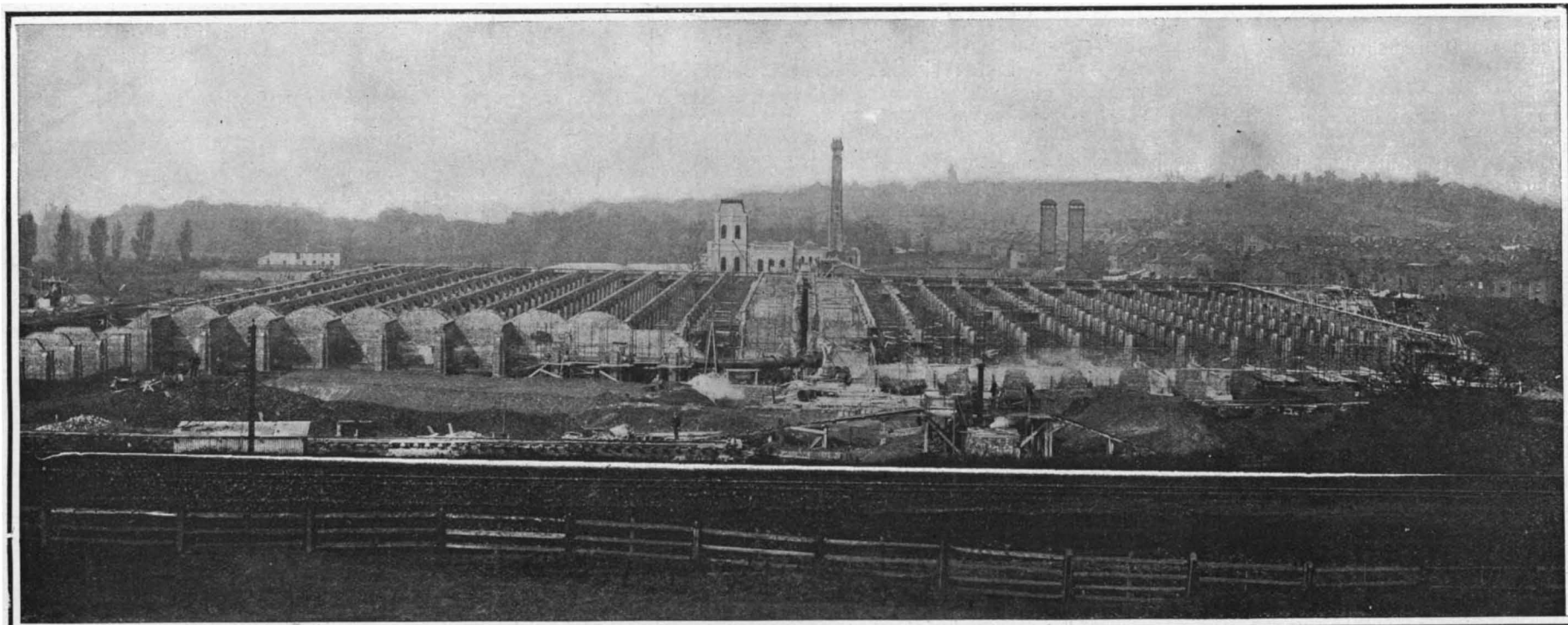

General view of the reservoir during construction.
A HUGE FILTERED WATER RESERVOIR FOR LONDON.

THE HEAVENS IN JULY.

BY HENRY NORRIS RUSSELL, PH.D.



HERCULES, which is the constellation represented in the initial of this sentence, while not as brilliant as some others, is one of the most characteristic figures in the summer sky. Its most distinctive configuration is a quadrilateral of third-magnitude stars, shaped like the keystone

of an arch, which at our hour of observation is almost exactly overhead, and which can always be easily found, since it lies about one-third of the way from Vega toward Arcturus. The rest of the constellation can be easily made out with the aid of the map. Several of its individual stars are noteworthy. The star α , in the hero's head, is one of the reddest of the brighter stars, and shows an especially fine banded spectrum—an evidence of relatively low temperature; and like many such stars, varies irregularly in brightness. It is also double, having a green companion, visible with a small telescope. ζ is also a fine double, having a companion, about 1/20 of its own brightness, which revolves about it in a period of 34 years. When the two are closest, they can hardly be separated by the greatest telescopes; but when they are farthest apart (as is nearly the case at present) the comparison can be seen with telescopes of moderate aperture, though still too difficult for small ones of three inches or less.

Another interesting system is μ , which has a faint companion 30 sec. distant, which shares in the large proper motion of its primary and is itself double, with a period of about 45 years.

Both these last two systems are tolerably near us, their distances being about 20 and 30 light years, according to the best determinations.

Still more interesting to the telescopic observer is the great star cluster (one of the finest in the heavens) which lies almost exactly on the western edge of the "keystone" between the stars ζ and η . It is clearly visible in a field glass as a spot of light with two small stars near it; but it requires much greater instrumental power to show the individual stars of which the cluster is composed.

There are thousands of them, scattered near the edges, but condensed to an almost continuous blaze of light at the center—a very impressive spectacle.

With an instrument which is not powerful enough to show the separate stars, the cluster is still easily visible, and looks nebulous, i. e., hazy and without sharp boundaries. If it were removed to a dozen times its present distance, it would present this appearance in our largest telescopes.

It is therefore natural to ask, Are not the numerous nebulae, of all sizes and shapes, which can be seen, or better photographed, in all parts of the sky, simply star clusters, so distant that the separate stars cannot be seen?

For an answer to this, we must appeal to that clue to many a riddle of the universe, the spectroscope.

It is well known that a spectrum showing bright lines is due to glowing gas, while a bright spectrum crossed by dark lines is given by a glowing opaque body surrounded by a gaseous atmosphere—in other words, a star.

Now the nebulae may be divided into two classes. Some, like the great nebula of Orion, are conspicuously green in color; others, like that in Andromeda, are white. Those of the former class show a spectrum of bright lines, which proves that they are composed, or rather that the luminous part of them con-

sists of, certain gases—hydrogen, helium, and others not yet identified. This has been known for forty years. But the white nebulae, among which are to be counted all those remarkable objects, the spiral nebulae, have till very recently defied investigation. They are so faint that nothing can be done with them visually, and photography demands very long exposures. One or two fairly successful plates, obtained by different observers, showed a continuous spectrum crossed by traces of dark lines; but the matter was still rather uncertain till the publication of some results recently obtained at the Lick Observatory by Mr. Fath. Using a specially designed instrument and very long exposures (continued for several successive nights) he has obtained photographs of the spectra of a number of white nebulae, which are of the highest interest. The results of the earlier observers are confirmed and extended. The great nebula of Andromeda, for example, shows a spectrum crossed by dark lines, such as would be given by a cluster of stars most of which were like the sun. Others show lines more like those in the spectrum of Sirius, and others a combination of dark and bright lines, as if they were composed both of stars and of luminous gas.

A number of star clusters, photographed for a test,

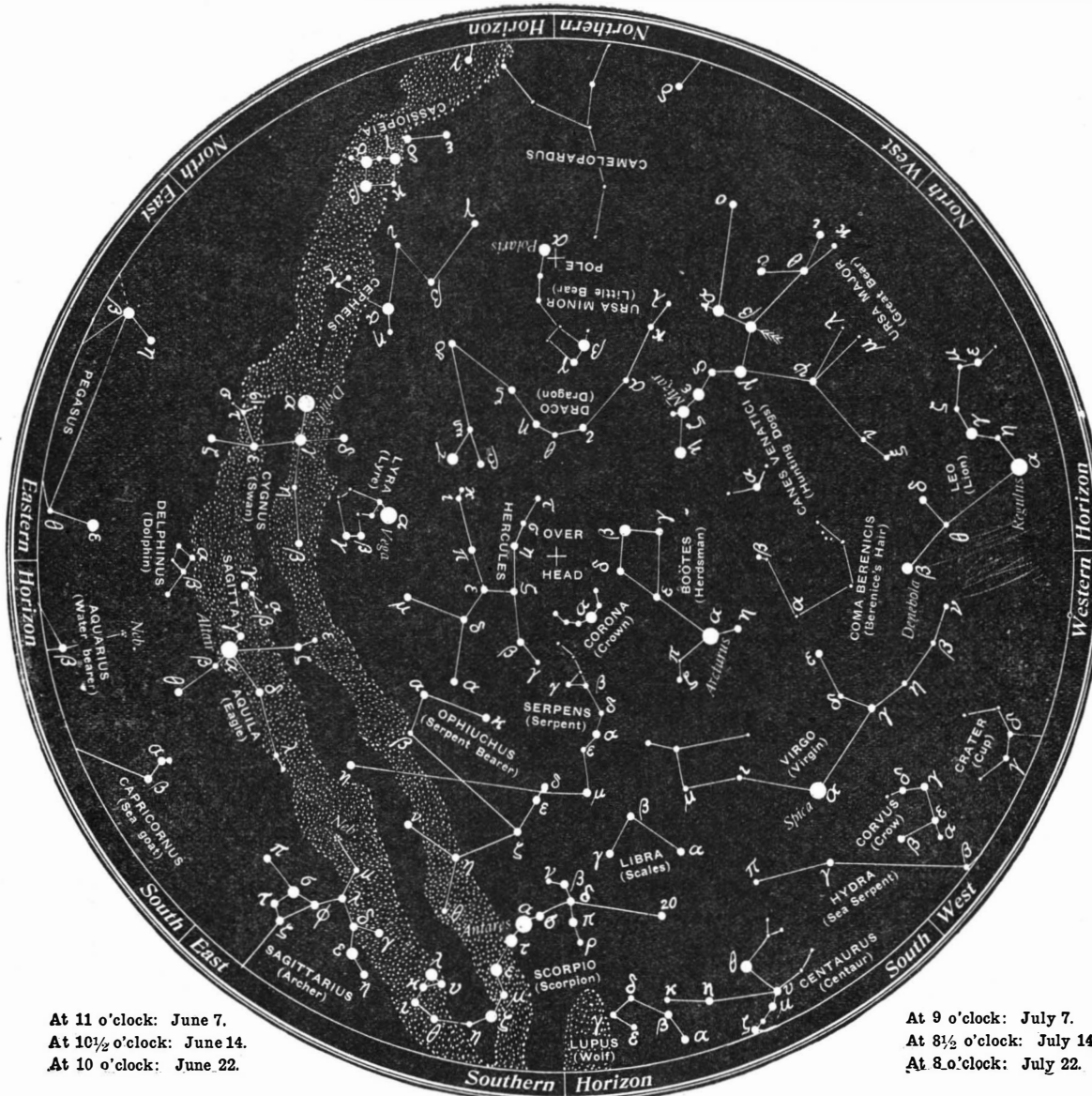

NIGHT SKY: JUNE AND JULY

showed clearly the dark-line spectrum predicted by theory. It seems therefore probable that these white nebulae are really star clusters of immense size at enormous distances. It will not do to speak too positively, for a determination of the parallax of the Andromeda nebula by Bohlin places it quite near us, at a distance less than twenty light years—in which case the component "stars" would have to be mere specks like the asteroids in order not to be directly visible. It is possible that this nebula may be an ordinary star like the sun, surrounded by foggy matter of some sort which obscures its direct rays, but is itself visible by reflected light; but further investigation is necessary before this question can be settled.

However, it seems almost certain that the Milky Way, viewed obliquely from a distance of thirty times its own diameter, would appear as a large oval, and probably spiral, nebula, giving a dark-line spectrum. And it is certainly open, to anyone who chooses, to believe that the Andromeda nebula, or others of the sort, are themselves distant galaxies comparable perhaps to our own, whose countless millions of stars betray themselves to our telescopes, even as those of the Milky Way do to our unaided eyes, merely as a spot of light in the sky.

THE HEAVENS.

South of Hercules is another large constellation, Ophiuchus, represented as a giant carrying a serpent (Serpens). The star α Ophiuchi, which marks his head, is close to α Herculis. His feet are far to the southward, near Scorpio and Sagittarius, both of which are well seen near the southern horizon.

Spica is at a moderate height in the southwest, and Arcturus almost above it. Leo, which contains the bright star Regulus and the far brighter planet Jupiter, is low in the west. Of the remaining zodiacal constellations, Libra is marked by a rather conspicuous pair of stars half way between Spica and Antares, and Capricornus and Aquarius are rising.

The two bright stars in the Milky Way, to the east, are Altair in Aquila and (on the left) Deneb in Cygnus. The still brighter star higher up is Vega, in Lyra.

Ursa Major and Draco are high up above the pole. Ursa Major is descending in the northwest, and Cepheus and Cassiopeia coming up in the northeast.

THE PLANETS.

Mercury is morning star all through the month, and is well observable during the first half of it. He is at his greatest elongation on the 7th, and rises about 3:40 A. M. At this time he is on the borders of Taurus and Gemini some distance from any bright star, and so should be easily recognized.

Venus is evening star in Cancer and Leo, setting about 8:40 P. M. in the middle of the month. On the evening of the 27th she is very near Regulus. Mars is in Pisces, and rises about 10 P. M. in the middle of the month. By its close he is within 50 million miles of the earth and very bright.

Jupiter is evening star in Leo, setting about 10 P. M. toward the middle of the month.

Saturn is in Pisces, east of Mars. He is in quadrature with the sun on the 15th, and is due south at 6 A. M.

Uranus is in opposition on the 11th. At this time he is in R. A. 19h. 23m. 5s.; declination 22 deg. 33 min. south—which places him in Sagittarius, about two-fifths of the way from the bowl of the Milk Dipper toward α and β Capricorni and far from any convenient reference stars for the naked eye. By making a diagram of the stars in this region, with the aid of a field glass, he can be identified by his motion, which is 10s. of R. A. to the west, and 20s. of declination southward, per day.

Neptune is in conjunction with the sun on the 9th, and is invisible all through the month.

THE MOON.

The moon is full at 7 A. M. on the 3rd, in her last quarter at 2 A. M. on the 10th, new at 6 A. M. on the 17th, and in her first quarter at 7 A. M. on the 25th. She is nearest the earth on the 7th, and remotest on the 23rd. She is in conjunction with Uranus on the 3rd, Mars on the 8th, Saturn on the 10th, Mercury on the 15th, Neptune on the 16th, Venus on the 18th, Jupiter on the 20th, and Uranus again on the 31st.

The *Artocaryus integrifolia*, bread-fruit, or Jach-tree growing wild in Java, gave its name to the locality. *Nongko Djadjar* (*Nongko* = bread-fruit tree, *Djadjar* = alley or avenue.) The height of the trunk is about 50 feet. The tree is very straight. This plant is not to be confounded with the other bread-fruit (*A. incisa*) which has the leaves pinnatifid; those of *A. integrifolia* has them entire. The fruits are 30 inches long and 12 inches broad; the weight is often 120 pounds. The flesh of these fruits is delicious. The oily seeds are eaten roasted. The wood is a beautiful yellow in color, hard, and is used for furniture and cabinet work. It is not attacked by white ants. When struck, the wood gives a very clear note. Hence bells are made of it, and pieces of the wood are also used by the watchmen in the mountain for giving signals. The leaves are used as an abradant.



TO INSTALL A MOTOR IN A SMALL BOAT.
BY MORRIS RADER.

Small marine engines can be bought so reasonably now, that many owners of small craft, skiffs, and canoes would install an engine were it not for the trouble and expense of putting on a skag and shaft

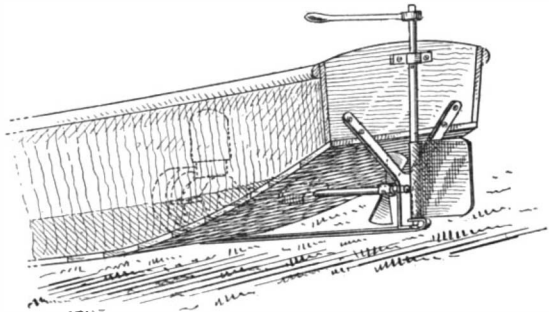

SHAFT BEARING FOR A SMALL BOAT.

log. An easy way to overcome this difficulty is shown in the diagram. It has been tried by the writer, and is a success.

A shaft bearing is made of iron, in the form of a Y, and fastened to the stern of the boat to support the shaft. A longer piece is fastened to this and to the bottom of the boat to protect the propeller. A projection of this in the rear will carry the rudder. A small shaft log is fitted inside the boat, with the stuffing box on the inside, which can easily be packed from the inside without removing the boat from the water.

HANDY MAN'S SURVEYING INSTRUMENT.

BY AUGUST MENCKEN.

While the surveying instrument of which a description follows is not very accurate, still if proper care be taken in its construction it will be accurate enough for all ordinary purposes.

It is built as follows: To the base, A, of 3/4-inch pine secure the uprights, B, B, of 5/16-inch pine. The body, C, of 1/4-inch pine, is hinged to the uprights by a 1/4-inch brass rod, which passes through a block, D, secured to the underside of the board C. On the body C are mounted the two sights E, E. They are made of brass and are hinged so that they can be folded down out of the way when the instrument is being carried. The sights must be mounted on the center line of the body. Two spirit levels F are mounted on the body C at right angles to each other. The compass G is fastened directly over the center of the instrument with four wooden fasteners. The position of the N, S, E, and W points can be seen on the drawing.

The "telescope," H, is mounted on the side of the base and is held in place by the two brass bands. It is made of 1-inch tubing with a 1/4-inch piece of brass tubing J, fitted in one end for the eyepiece. At the other end are two cross hairs. This is used for leveling. The protractor K is fastened to the block D and is used to measure vertical angles. As the body is moved the protractor turns past the pointer L and

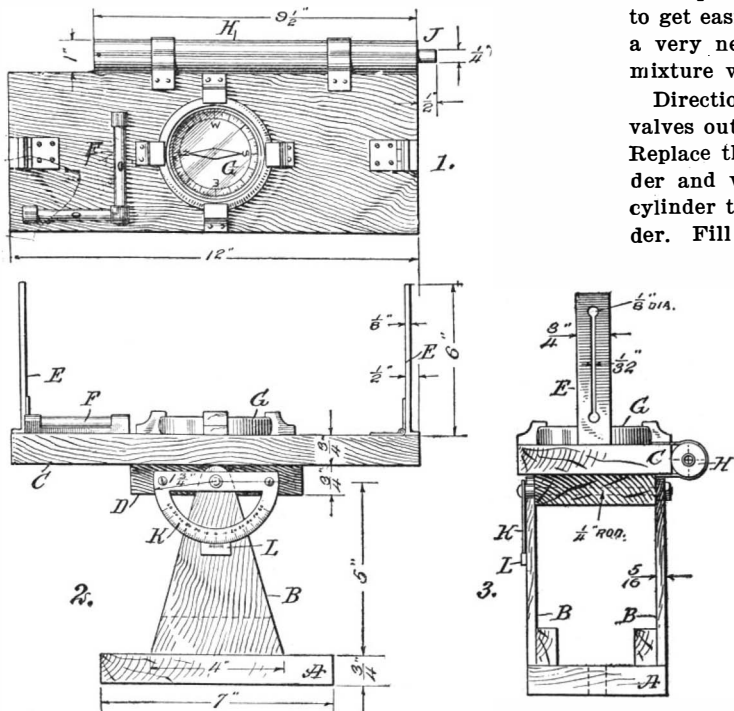

CONSTRUCTIONAL DETAILS OF THE SURVEYING INSTRUMENT.

the number of degrees in the arc it turns can be easily read. The instrument is put together with brass screws.

A tripod can be readily made out of three 1 1/4-inch poles about 4 1/2 feet long, hinged to a top. The instrument is fastened to the tripod with a 1/4-inch bolt.

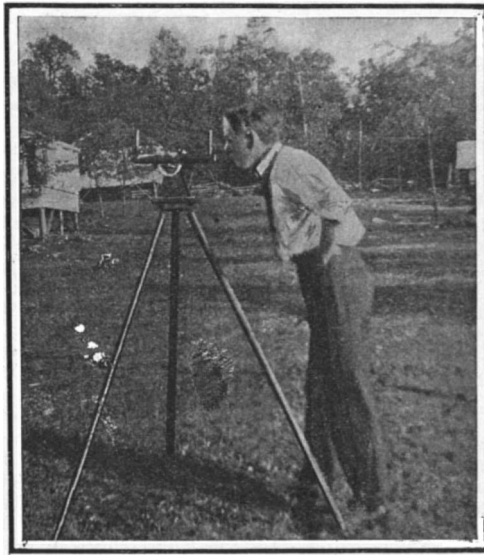

THE SURVEYING INSTRUMENT IN USE.

The instrument cost the writer about \$2.50 and up to the present has paid for itself several times on small jobs.

A HOME-MADE SPRAY OUTFIT.

BY CHARLES A. UMOSELLE.

The spray pump described below cost me \$11. One of standard make and not so powerful was priced at \$45. Any ordinary workman who is handy with tools could put my sprayer together in a day. It has proven so valuable to me that I wish to make it known to everybody. It was assembled from the following: A riding cultivator frame, pole, and wheels (old scrap

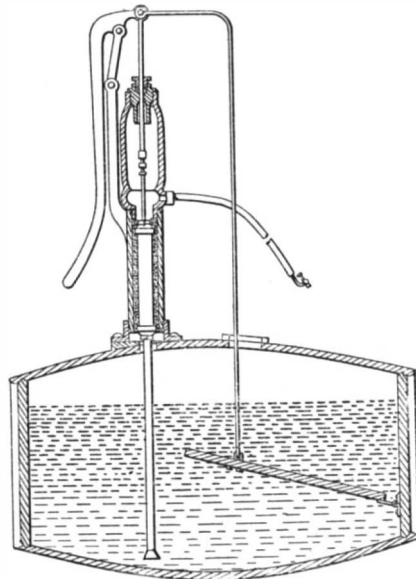

SECTION SHOWING ARRANGEMENT OF AGITATOR.

iron) a good coal-oil barrel (price \$1), a 3-inch cylinder cast-iron force pump (\$6), a plain brass 2-inch cylinder and valves (\$2), a piece of good 3/4-inch hose and a spraying nozzle (\$2). Total cost, \$11. After putting the above material together I was able to get easily a pressure of 150 pounds per square inch, a very necessary prerequisite to apply the Bordeaux mixture with the right force.

Directions for assembling are as follows: Take the valves out of the cylinder of any cast-iron force pump. Replace these valves with the plain brass 2-inch cylinder and valves. Cut off with a hack saw the 2-inch cylinder to the right length to just fill the cast cylinder. Fill in the space between cast cylinder and brass cylinder with plaster or cement, being sure that the brass cylinder is in the exact center of the cast cylinder. Attach the plunger valve of brass cylinder to the plunger piston of the force pump, and couple up the piston to the handle of the pump so as to get a full stroke. As only a small amount of liquid is needed in spraying, the object of this reduction of cylinder is to lessen the flow and increase the pressure. The reduction of 3 to 2 halves the flow and doubles the pressure. Mount the pump on the barrel and the barrel on the riding cultivator frame. Make an agitator as follows: In the barrel, near the bottom, on the end or head of the same, hang with a T-hinge a board made of oak 1 x 6 x 2 feet to swing up and down. Connect the board with the pump

plunger by a steel rod so that it will swing up and down with the stroke. The steel rod should enter the barrel through an opening made to pour in the liquid.

I use this machine to spray my hen house with lime and coal oil at the rate of 100 square feet per

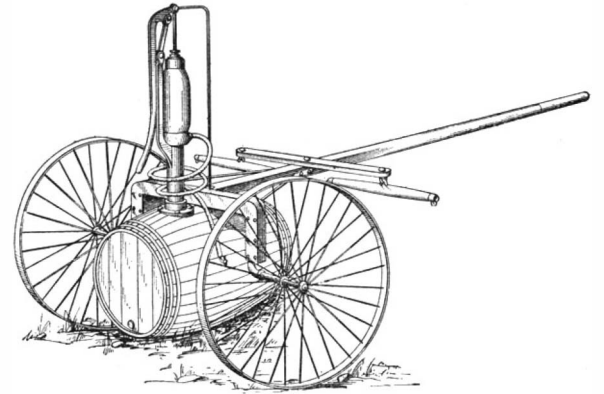

THE HOME-MADE SPRAYER COMPLETE.

minute. It makes a good job at whitewashing as well and is death to bugs and microbes on my fruit trees.

HOW TO MEND GARDEN HOSE.

BY J. A. BERGSTROM.

As the garden hose gets a little old, and begins to swell, it soon gets out of commission altogether if not attended to.

A simple way to mend it is to wrap the hose with ordinary twine, which will make it last a few more seasons. As it is no easy matter to wind this cord by hand and get it even and under uniform tension, the writer has for many years used the simple contrivance shown in the accompanying illustration.

It consists of an ordinary tin can with a lid, into which is put the ball of twine. In the center of the bottom make a small hole, through which pass the loose end of the cord. Thence let it run down the side of the can through a tension device and to the hose. To the cover of the can is soldered a small piece of tin, bent to a right angle and forming a guide for the hose. The tension device consists of a short

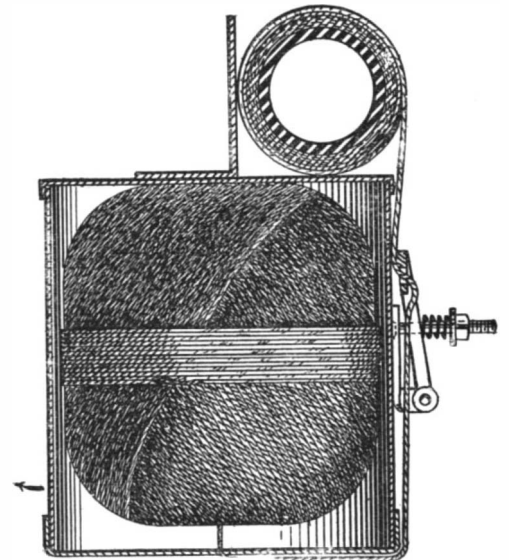

DEVICE FOR WRAPPING GARDEN HOSE.

piece of metal, with its upper end bent outward, forming a fulcrum for a short spring-compressed lever. The latter at its lower end has a small hole therein through which the cord is passed. A short stove bolt serves to regulate the tension on the lever. It will be observed that the cord is pressed against the can by the lever. The whole device is now soldered to the tin can.

In use, the can is turned around the hose, and with the tension properly adjusted, the twine will wind around the hose very closely, and it will feed the can forward automatically. It will make the hose slightly smaller, and thus close all the small punctures, through which the water percolates, between the several layers of the canvas. By giving the cord a coat or two of some waterproofing, it will be found that the hose will last as long again; besides, it will stand a great deal more pressure than before.

A GOOD SUBSTITUTE FOR LEATHER BELTING.

An excellent substitute for leather belting can be made from a piece of ordinary fire hose, splitting it up the middle into two parts, i. e., two belts can be made from one piece of hose. The writer has seen this done on more than one occasion, with perfect satisfaction.

According to a contemporary, the largest transmission line in the world is that of the Niagara-Syracuse-Auburn line, which transmits 30,000 horse-power over a distance of 163 miles. The line in parts is designed to carry 60,000 horse-power.

RECENTLY PATENTED INVENTIONS.

Pertaining to Apparel.

SEPARABLE BUTTON.—E. C. KAAG, New York, N. Y. The aim of this invention is to provide a separable button for use on cuffs, collars, garments, and other articles, and arranged to permit convenient separation of the members and easy assembling thereof to unite the members, without danger of accidental disengagement when the button is in use.

OVERALLS.—W. F. HARBOUR and G. A. KELLOGG, Atlanta, Ga. The object of this invention is to provide simple, inexpensive, and easily manufactured overalls, having aprons which can be positioned within the overalls so that the latter become similar to ordinary trousers, and in which the apron can be operatively positioned and attached to the suspenders.

HAIR ORNAMENT.—A HOCHHEIMER, New York, N. Y. In this instance the invention is an improvement in ornaments for use for the hair, and has in view a device capable of supporting a number of feathers or plumes, and which may be easily applied and secured to the hair at various points and readily detached.

NECKTIE-HOLDER.—W. DOWNING, Pawling, N. Y. The improvement has reference to necktie holders, provided with a cross bar adapted to be passed through the body of a tie, after the latter has been tied in the preferred form on some suitable object, such as a pencil, a stick of wood, or the like, and after the latter has been withdrawn.

LIFE-BELT.—D. BOUWMAN, Bussum, Netherlands. The invention relates to life belts, the more particular improvement consisting in providing such belts with air compartments adapted to collapse or fold and to normally remain folded, but ready to be spread or inflated at a moment's notice when the belt is to be used.

METHOD OF FORMING TIPS OF SHOELACES.—MARY A. BARTELS, Watchung, N. J. The object of this invention is to provide a new and improved method for forming tips of shoe laces, in a very simple and economical manner and with a view to render the tip permanent, without the use of metallic stiffening, and to allow of giving the tip the same color as that of the body of the shoe lace.

Electrical Devices.

RECEIVER FOR WIRELESS SIGNALING.—H. C. CAYLEY, Riverside, Cal. The invention provides an improved wave detector; makes the detector self-registering and self-adjusting within certain limits; provides a number of hand-operated adjustments for increasing sensitiveness of the detector; connects the detector and its parts in a circuit so arranged as to subject the receiver to current changes, and to cause the exaggeration of said changes for the purpose of rendering the indications loud and clear.

ELECTRIC TESTING INSTRUMENT.—H. G. ADDIE, Cresco, Iowa. In this case the invention refers to testing instruments and admits of general use, but applies more particularly to a type of such instruments used for testing fuses and made in neat form to be carried in the pocket and containing its own supply of current for making the test.

Of Interest to Farmers.

BUTTER MEASURER AND CUTTER.—D. F. CURTIN, St. Louis, Mo. The object of the invention is to provide a device by means of which butter may be cut into prints or blocks and conveniently separated from the rest of the butter in the tub or package, the blocks being of predetermined weight, thereby dispensing with the necessity of weighing the butter, as now commonly done.

Of General Interest.

MOUTH AND NOSE PROTECTOR.—B. WOLFF and T. W. RICHARDS, New York, N. Y. By the use of this invention, dust and other flying particles or germs are prevented admission to the nose and mouth. The guard is formed of two separate sections flexibly connected together, one adapted to cover the mouth and the other the nose, and used in connection with a support which serves to hold both sections in their proper position.

TAPE-GRIP.—L. D. RICHARDSON, Providence, R. I. In its broadest aspect the invention may be defined as consisting of a rigid bar member of substantially one-half of the length of the first and secured to one face thereof, and means including a lever, pivoted to said second bar member for clamping the tape between it and the first mentioned bar member.

FLAG AND BANNER SUPPORT.—E. H. B. LINDHORST, San Francisco, Cal. The support is capable of being raised to or lowered from the truck of a flag pole by means of the customary halyards, and is constructed so that the said support will be maintained at right angles to the pole when there is no breeze, and in a breeze will occupy the same position but will wave and turn in conformity with the breeze.

FIRE-EXTINGUISHING SYSTEM.—C. T. ROBERTS, Tucson, Ariz. More particularly the invention pertains to sprinkling systems for mine shafts, although it is evident that the system might be utilized equally as well in various other localities. The object is to deliver the water to the system in such a manner as to prevent the burning of the wood-

work of the shaft and to prevent the passage of flames from one level to another.

VULCANIZING APPARATUS.—A. F. COGSWELL, Pretty Prairie, Kan., and J. W. PUCKETT, Geneva, Neb. This furnace overcomes former difficulties, and automatically controls and regulates the process without attention from the dentist, and when the vulcanizer is brought to proper temperature it closes a sectional oven about the same, so as to maintain even and prolonged heat, and it shuts off the supply of fuel oil, gas, or heating agency, thus saving fuel, time, avoiding mistakes, etc., without attention from the dentist.

PAPERING APPARATUS.—O. O. CAREY, Converse, Ind. More particularly the invention relates to means for smoothing the paper on the wall after it has been hung, and further means for cutting the paper at the base board. An object is to provide an apparatus which may be used in paper hanging to smooth the paper in position, to cut the paper off at the base-board, and to press out the edges.

CONCRETE CONSTRUCTION AND METHOD OF PRODUCING THE SAME.—G. A. M. LITJENCRANTZ, Chicago, Ill. Blocks made by this process may be used in constructing new superstructures over cribs sunk to the proper height; for rebuilding superstructures over old crib work; for new pier work where large blocks should be placed on a pile foundation sawed off at a suitable height; for docks or rivers where the bottom consists of solid rock; for bridge abutments or intermediate piers; for retaining walls, dams, and other heavy structures, where the cross-section and base must be of considerable magnitude and would make the work very expensive if of solid concrete.

AUTOMATIC SPEED-CONTROLLER.—C. E. PALMER, Spokane, Wash. When adjusted the device may remain in position for use as a means of reaching the ground in case of fire, or for other purposes. As a fire escape, the person may cling to the rods, with the assurance that the controller will regulate his descent, by means of the sprocket chains traveling on the sprocket wheels, connected with the mechanism, for regulating the rotation of the cylinders and the rotary pistons which are connected with the sprocket wheels.

Hardware.

LOCK.—W. J. LAMBERT, North Yakima, and E. P. DOPPS, Sunnyside, Wash. One object in this invention is to provide a simple, strong, and durable combination or permutation lock which is inexpensive to manufacture, which can be easily operated, and which it is practically impossible to unlock without destroying the lock, unless the proper combination or permutation is known.

WINDOW-FASTENER.—W. AGIN, Chillicothe, Ohio. The device comprises a casing, bolts arranged at right angles to each other and movable through the casing, one being provided with an enlarged portion having a transverse recess, with an inclined inner edge, the other having a cam within the recess and engaging the inclined face of the recess and a spring between the enlarged portion of the bolt and the casing wall, and a latch pivoted to the enlarged portion of the end wall of the casing having a slot through which the latch passes, the latch having a catch for engaging the edge of the slot for retaining bolts in retracted position.

Heating and Lighting.

APPARATUS FOR WATERING COKE-OVENS.—D. B. STAUFF, Scottsdale, Pa. The invention is an improvement in appliances of the character disclosed in Letters Patent formerly granted to Mr. Stauff, for watering coke-ovens, the present invention being particularly directed to improvements in the pivotal support of the revolving sprinkler-pipes, and has for a purpose to provide for the adjustment of the tubular pivot and prevent leakage thereabout.

METHOD FOR PREVENTING THE FORMATION OF BOILER-SCALE.—T. BRAZDA, Amstetten, Austria-Hungary. The subject-matter of the invention is a method for preventing the formation of boiler scale, or for preventing the formation of incrustation on the walls of steam boilers and other receptacles under pressure. The method differs from chemical and mechanical processes, or those known heretofore, as the feed water is introduced into the boiler without admixture of chemicals and in a definite form in which it prevents formation of scale.

Machines and Mechanical Devices.

EXPANSION CUTTER-HEAD FOR BORING BARS.—CHARLES M. BUCK, Huntington, W. Va. The tool is particularly adapted for boring the hubs of car wheels, although it will be found serviceable in many other applications. It is in the form of a mandrel with a boring head in which adjustable cutters are seated. The cutters are separately adjusted so that one pair can be used as roughing cutters and the other as finishing cutters. An illustrated description of this tool appeared in the issue of June 19th, but the title contained a typographical error, making it read "Cutter Head for Boring Brass" instead of "Boring Bars."

NOTE.—Copies of any of these patents will be furnished by Munn & Co. for ten cents each. Please state the name of the patentee, title of the invention, and date of this paper.



Kindly write queries on separate sheets when writing about other matters, such as patents, subscriptions, books, etc. This will facilitate answering your questions. Be sure and give full name and address on every sheet.

Full hints to correspondents were printed at the head of this column in the issue of March 13th or will be sent by mail on request.

(12107) A. K. says: 1. Is the direction of an electric current from positive to negative, or the reverse? A. The direction of an electric current is always taken to be from positive to negative. This is, however, entirely conventional. We could as easily do all electrical work and make all calculations on the theory that the current flows from minus to plus. It is simply by agreement that we consider that pole of a battery plus which is at the end of the carbon plate. 2. Are the two ends of an electrode of the same sign? A. One end of a plate in a battery cell is plus and the other minus. An electrode is the end of an electric circuit, and is of the opposite sign from the other end. The zinc in a cell is plus. The end of the circuit attached to the zinc is the minus electrode of that circuit. 3. Does the current of electricity enter an X-ray tube at the anode or cathode? A. The current is considered to enter a Roentgen ray tube at the anode. The cathode rays stream from the cathode, and strike the anode, producing the rays from the anode. 4. What is the effect of X-rays upon the skin exposed to them for a time? A. The Roentgen rays are very injurious to one exposed for a long time to them, producing even death.

(12108) P. G. F. says: Can you give me the scientific theory of what causes diamonds to form in the earth, and what kind of mineral do they form out of before they become a diamond? If you cannot give me any information on diamonds, please inform me where I can get the information. A. Carbon exists in three forms—charcoal, graphite, and diamond. Heat and pressure are thought to be the forces necessary to change the substance from one to the other of the higher and harder forms. Some diamonds have been made artificially by placing carbon in powdered form in melted iron. The iron is then suddenly chilled and cooled, with the result that an enormous pressure is brought upon the carbon particles, and upon dissolving the iron away, tiny pieces of carbon are found as hard as a diamond. They are of microscopic size, but are of interest as possibly illustrating how diamonds have resulted under the great heat and tremendous pressure which have existed in the interior of the earth in remote times. The diamonds which are mined in South Africa are found in holes or pipes, which lead down through the rock strata into the interior of the earth, and it is suggested that they have been brought up from an unknown depth in the melted rock. SUPPLEMENT No. 1571, price 10 cents, deals with the genesis of the diamond.

(12109) F. J. says: I note in your issue of May 15th, in reply to query 12084 you say that the number of contacts between the blades on disks A and B are the same, whether one disk is stationary or whether they both revolve in opposite directions at ten thousand R.P.M. I beg to call your attention to the fact that you have not taken into consideration the distance traveled by the circumference of each disk; therefore if disk A, with ten blades, revolving at ten thousand R.P.M., comes in contact with one blade of stationary B one hundred thousand times in one minute, then if B is started revolving in the opposite direction at the same rate of speed, the number of contacts is exactly double, for the reason that each blade has only to move one-half the distance to make the contact when both disks are revolving. This solution is taken from your diagram, which shows that the disks revolve in a direction so that they strike each other. If the disks revolve in such manner that they would mesh together like the cogs of a wheel, your solution would be correct, and there would be no difference as to whether one or both disks were revolving. A. We thank you for your correction, which is certainly just. Our reasoning was based on the rotation of the wheels in opposite directions, as if they were intermeshing gears, and we overlooked the direction of the arrows on the inquirer's sketch.

(12110) C. N. T. says: As I understand it, the Thermos bottle is constructed on the principle that vibrations will not cross a vacuum. If this is correct, how does an incandescent electric light, with a carbon film in a vacuum, give off both light and heat? A. The Thermos bottle is constructed on the principle that heat waves of low radiant energy will not pass through a vacuum. Heat waves of high radiant energy, such as those from a fire or incandescent body, a lamp filament or the sun, will pass easily through a vacuum. A thermometer enclosed in a vacuum will respond to the heat of a match or of the electric lamp. The little radiometer is often seen in jewelers' windows whirling in the sun rays to attract attention. Its vanes are in a vacuum.

NEW BOOKS, ETC.

MODEL AEROPLANES. How to Build and Fly Them. By E. W. Twining. New York: Spon & Chamberlain, 1909.

This booklet, together with the five sheets of full-sized working drawings which accompany it, will fill a long-felt want of many people interested in aeronautics. Full particulars are given as to how to build several different types of model aeroplanes. By following the working drawings it is possible for any amateur to construct a working model of the Wright or Voisin machines that will actually fly and which will be the source of considerable scientific amusement. In view of the craze which has recently started abroad of toy aeroplanes, this little booklet and drawings will be found very timely by most amateurs.

TROUBLE FINDER CHART FOR AUTOMOBILISTS. By Roger B. Whitman, Technical Director of the New York School of Automobile Engineers. New York: Whitman & Cameron. Price, 50 cents.

This chart, which was originally published in the last Automobile Number of the SCIENTIFIC AMERICAN, is the most complete chart of the kind which has been brought out up to the present time. In supplying it printed in sections on separate cards, the author has made it available in a very handy fashion for all automobilists. There are about a dozen cards dealing with effects of trouble; make-and-break ignition; jump-spark ignition by battery and coil and by low-tension or high-tension magneto and coil; carbureter; compression; fuel-feed system, and care of tires, operation and maintenance. Two of the most useful cards give lubrication tables, showing how to oil every part of the car, while most of the other cards give a complete diagnosis of the troubles that may occur with the different organs, so that any novice can soon locate the trouble and make the necessary repair. This chart will be welcomed by all automobilists.

MRS. RORER'S VEGETABLE COOKERY AND MEAT SUBSTITUTES. Philadelphia: Arnold & Co., 1909. 12mo.; 28 pages. Price, \$1.50 net.

Mrs. Rorer is regarded, and justly so, as being one of the greatest authorities in the world on the subject of cookery, and her views are perhaps more widely quoted than those of any one else in the culinary world. The great value of Mrs. Rorer's books is the extreme accuracy with which she pens her receipts. They seldom, if ever, fail if the directions are properly followed. There is no more acceptable book for the housekeeper than Mrs. Rorer's New Cook Book, which the present volume admirably supplements. It is very often said that we use too much meat in our American cuisine, and in fact "the American breakfast" is looked upon with horror abroad. It appears to be a fact that many persons can perform their work much better if they have no meat in the morning, and much of the hardest traveling in Europe is done with only the continental breakfast of rolls and coffee. Breakfast, however, with the aid of this book can occupy a middle ground between the sodden meat breakfast and the scanty French breakfast. Many of the meat substitutes are admirable. The receipts are very carefully arranged, and the book is well printed and bound. It is one which we can heartily commend to all our readers.

BOX FURNITURE; HOW TO MAKE A HUNDRED USEFUL ARTICLES FOR THE HOME. By Louis Briegham. New York: The Century Company, 1909. 12mo.; 304 pages. Price, \$1.60 net.

The author has produced a very remarkable work. It is very curious what can be done with a few old boxes. Here are some of the articles enumerated: Plant box, golf-stick stand, kitchen stool, hanging lantern, coal box, blacking box, clock case, spice box, pipe rack, knick-knack brackets, housewife's handy rack, magazine racks, shoe cupboards, flower stands, wash stands, writing desks, book cases, music stands, office files, game tables, nature study stands, photographic material stands, clothes presses, chafing-dish table, firewood rack, wall rack, tea table, window seat, corner seat, wardrobe, sideboard, shaving table, china closet, hall stand, etc. In each case illustrations are given. The requirements as to raw materials are stated. Then comes a detailed description of the construction. We have not seen any book that has told how to make things which has been anything like as practical in a very long time. This work not only describes how to make single articles of furniture, but takes up whole rooms as well, as "The Nursery," "The Den," "Living Room," "Twin Bed Room," "College Boy's Corner," "Kitchen," "Office," "Boy's Room," "School Room," "Dining Room," "Club Room," "Library," or "Study." The book is most attractively gotten up and cannot fail to have a well-merited success.

WIRELESS TELEPHONE CONSTRUCTION. By Newton Harrison, A.E. New York: Spon & Chamberlain, 1909. 18mo.; 74 pp. Price, 25 cents.

This is a comprehensive explanation of the making of wireless telephone equipments for receiving and sending stations, with details of construction. This little book is admirably illustrated with very clear diagrams.

THE FOURTH DIMENSION. (Concluded from page 6.)

an axis line, and in hyperspace about an axis plane. Two symmetrical plane figures such as the triangles A and B (Fig. 3) cannot be made to coincide by any movements in their own plane, but by rotating one of them 180 deg. in the third dimension, it can be made to coincide with the other. Similarly, two symmetrical volumes (with faces equal but in reverse order) such as the hollow pyramids C and D (Fig. 4) cannot be made to coincide by any movements in our space, but by rotating one of them 180 deg. in hyperspace this can be done. The rotating pyramid disappears from our space, and upon its return after rotating 180 deg. it can be slipped into the other. In our space two movements of rotation will combine into a single resultant rotation, similar to its component rotations except that the direction of the axis is different. In hyperspace, however, there is in general no resultant for two rotations. Hence there are two different types of rotation in hyperspace and a body subject to two rotations is in a totally different condition from that which it is in when subject to one only. When subject to one rotation a whole plane of the body is stationary. When subject to the double rotation no part of the body is stationary except the point containing the two planes of rotation; and if the two rotations are equal, every point in the body, except that one, describes a circle.

Freedom of movement is greater in hyperspace than in our space. The degrees of freedom of a rigid body in our space are 6, namely, 3 translations along and 3 rotations about 3 axes, while the fixing of 3 of its points can prevent all movement. In hyperspace, however, with 3 of its points fixed it could still rotate about the plane passing through those points. A rigid body has 10 possible different movements in hyperspace, namely, 4 translations along 4 axes, and 6 rotations about 6 planes, while at least 4 of its points must be fixed to prevent all movement. A material point in our space can be prevented from moving by connecting it rigidly with three fixed points outside; in hyperspace it must be rigidly connected with at least 6 points outside.

In hyperspace, a sphere if flexible could without stretching or tearing be turned inside out. Two rings of a chain could be separated without breakage. Our knots would be useless. Thus the knot shown in Fig. 5 could be unknotted without removing the fastened ends. Just as in our space a point can pass in and out of a circle without touching its circumference, so in hyperspace a body could pass in and out of a sphere (or other inclosed space) without going through the surface surrounding it. In short, all of our space including the interior of the densest solids is open to inspection and manipulation from the fourth dimension, which extends in an unimaginable direction from every point of space.

Has hyperspace a real physical existence? If so, our universe must have a small thickness in the fourth dimension, otherwise like the geometrical plane assumed to be without thickness, our world too would be a mere abstraction (as indeed some idealistic philosophers have maintained), that is, nothing but "a shadow cast by a more real four-dimensional world." The real existence of a slight extension in the fourth dimension would, moreover, simplify certain scientific theories. For instance, in our space 4 is the greatest number of points whose mutual distances, 6 in number, are all independent of each other; but in hyperspace the 10 distances between any 2 of 5 points are geometrically independent. If this greater freedom of position were permissible to atoms, it would help to explain such chemical phenomena as isomerism, where molecules of identical composition have different properties. Again, rotation in hyper-

"Star" Foot and Power Screw Cutting Lathes. FOR FINE, ACCURATE WORK. SENECA FALLS MFG. CO. 695 Water Street, Seneca Falls, N. Y., U. S. A.

Engine and Foot Lathes. MACHINE SHOP OUTFITS, TOOLS AND SUPPLIES. BEST MATERIALS. BEST WORKMANSHIP. CATALOGUE FREE. SEBASTIAN LATHE CO., 120 Culvert St., Cincinnati, O.

Veeder Counters. Price \$1.00. to register reciprocating movements or revolutions. Cut full size. Booklet Free. VEEDER MFG. CO., 18 Sargeant St., Hartford, Conn.

\$54.00 per day THE RECORD of the CAMERA-SCOPE. And we can prove it. Anyone can operate it. Makes 6 finished button photographs a minute. Price of Camera-Scope, with supplies for making 300 pictures (enough to pay for the complete outfit) \$25.00.

THE "BARNES" Upright Drills. Positive Feed. 10 to 50-inch Swing. Send for Drill Catalogue. W. F. & JNO. BARNES CO. (Established 1872) 1999 Ruby St., Rockford, Ill.

Does Your Motor Always "Mote"? Perhaps the trouble lies in faulty ignition current. The best insurance against this kind of trouble is the Hubler-Dayton Storage Battery.

WHAT WE DO—HOW WE DO IT. We will be sent to you on request. KNICKERBOCKER MACHINE WORKS, Inc., 8-10-12 Jones Street, New York

Crescent Wood Working Machinery. Better than some that may be offered you at a higher price. Band Saws, Saw Tables, Jointers, Shapers, Boring Machines, etc.

GOES LIKE SIXTY SELLS LIKE SIXTY \$60 GILSON GASOLINE ENGINE. For Pumping, Cream Separators, Churns, Wash Machines, etc. FREE TRIAL. Ask for catalog—all sizes. GILSON MFG. CO., 308 Park St., Fort Washington, Wis.

Print Your Own. Cards, circulars, book, newspaper. Press \$5. Larger \$18. Save money. Print for others, big profit. All easy, rules sent. Write factory for press catalog, type, paper, etc. THE PRESS CO., Meriden, Connecticut.

Palmer Motors and Launches. Two and Four Cycle. One, Two and Four Cylinder. Stationary and Marine. One to Twenty H.P. Catalogue FREE. PALMER BROS., Cos Cob, Conn.

SPARK COILS. Their Construction Simply Explained. Scientific American Supplement 160 describes the making of a 1 1/2-inch spark coil and condenser. Scientific American Supplement 1514 tells you how to make a coil for gas-engine ignition. Scientific American Supplement 1522 explains fully the construction of a jump-spark coil and condenser for gas-engine ignition. Scientific American Supplement 1124 describes the construction of a 6-inch spark coil. Scientific American Supplement 1087 gives a full account of the making of an alternating current coil giving a 5-inch spark. Scientific American Supplement 1527 describes a 4-inch spark coil and condenser. Scientific American Supplement 1402 gives data for the construction of coils of a definite length of spark. The above-mentioned set of seven papers will be supplied for 70 cents. Any single copy will be mailed for 10 cts. MUNN & COMPANY, Publishers 361 Broadway New York

PATENTS. INVENTORS are invited to communicate with MUNN & Co., 361 Broadway, New York, or 625 F Street, Washington, D. C., in regard to securing valid patent protection for their inventions. Trade-Marks and Copyrights registered. Design Patents and Foreign Patents secured. We undertake all Patent, Trade-Mark and Copyright Practice, both before the Patent Office and the Courts, and we have special facilities for handling Infringement and other suits in Federal and State jurisdictions. A Free Opinion as to the probable patentability of an invention will be readily given to any inventor furnishing us with a model or sketch and a brief description of the device in question. All communications are strictly confidential. Our Hand-Book on Patents will be sent free on request. Every patent secured through us receives special notice in the Scientific American. Ours is the Oldest agency for securing patents; it was established over sixty years ago. MUNN & CO., 361 Broadway, New York Branch Office, 625 F St., Washington, D. C.

INDEX OF INVENTIONS. For which Letters Patent of the United States were Issued for the Week Ending June 22, 1909, AND EACH BEARING THAT DATE. [See note at end of list about copies of these patents.]

Table listing various inventions and their patent numbers. Includes items like 'Adding and listing machine', 'Adjustable bit', 'Animal trap', 'Apron', 'Automobile', 'Bicycle coaster brake lock', 'Boiler gage glass', 'Bookcase', 'Bottle heater', 'Bottle, anti-refillable', 'Bottle, sanitary', 'Butter cutting machine', 'Cable chain grip systems', 'Caloric engine', 'Can attachment', 'Can body forming and soldering machine', 'Can opener', 'Canister, non-refillable', 'Car brake', 'Car brake operating mechanism', 'Car, concrete', 'Car coupling', 'Car coupling, carry iron', 'Car derailing device', 'Car door, box freight', 'Car, dumping', 'Car emergency brake', 'Car, passenger', 'Car stake', 'Car step raising device', 'Car stop', 'Car underframe', 'Carburetor', 'Carburetor, E. P. Warren', 'Card holder', 'Carton of package', 'Cash register', 'Caskets or burial vaults', 'Casting metal structures', 'Centrifugal machine', 'Chain links', 'Chains, making'.

space would explain the change of a body producing a right-handed into one producing a left-handed polarization of light. Further, Prof. McKendrick said before the British Association: "It is conceivable that life may be the transmission to dead matter . . . of a form of motion sui generis." Hyperspace has been brought somewhat in disrepute because spiritualists have assumed its existence in order to give "a local habitation" to their vagaries. Nevertheless, the possibility of its existence has not yet been shown to be inconsistent with any scientific fact, and the limitation of space to three dimensions, though probably correct, is therefore purely empirical.

Of what use then is the conception of hyperspace? For one thing, it gives a deeper insight into geometry. Thus, a circle considered merely as a one-dimensional aggregate of points has very few properties, while in a plane it has a center, radii, tangents, etc., and in 3-space has further numerous geometrical relations with the sphere, cone, etc. Similarly, the properties of any given line or surface increase in number when investigated in hyperspace. Also, just as it requires a 3-space to include certain one-dimensional aggregates (the helix, for instance), so in hyperspace hitherto unknown lines and surfaces become mathematically possible. Lower spaces are contained in higher (if curved, not necessarily the next higher); and just as the comprehension of plane geometry is enlarged by viewing plane figures in 3-space, so solid geometry is much illuminated by the geometry of hyperspace. fields of mathematics hitherto inaccessible to geometry are now elucidated by geometrical representations. Finally, this conception effects a complete divorce between geometric space and real space, no longer considered necessarily identical, and in other ways also enlarges our mental horizon.

A MUSEUM TO ILLUSTRATE THE DEVELOPMENT OF MATHEMATICS.

(Continued from page 10.) two astrolabes of Italian make and dating back to the fifteenth and sixteenth centuries are illustrated, so that it is possible to appreciate their fine workmanship and the accuracy of the division of the circular scales. Then at this time there were various forms of celestial spheres, planispheres or armillary spheres, where a number of concentric circles were used to illustrate the motion of earth and planets. In the celestial sphere, a sixteenth century example of which of Italian workmanship is shown herewith, the principal circles of the heavens are represented, as well as the polar axis located within meridian and horizon circles, at the center of which the observer is supposed to be. With such armillary spheres, of which the collection contains a number of specimens, the motions of planets and earth could be shown, and also direct measurements could be made. Not only are there Italian and German instruments of this kind dating back to the fifteenth and sixteenth centuries, and used by such astronomers of that time as Tycho Brahe, but there are similar instruments from India, Persia, and Arabia, one of which in modern times was used by Pandit Joshti in the restoration of the ancient observatory of Jaipur, India. The similarity of the instruments of Europe and Asia is very striking, and interest is heightened by the exhibition with the latter of Hindu and Persian texts explaining their use. Indeed, the correspondence between the methods and instruments of peoples remote from one another as brought out in the exhibition is often most impressive, and a comparison of a Japanese sphere of the sixteenth and seventeenth centuries with European spheres of the same period shows many points of identity. Not a few Japanese instruments and manuscripts are included in the collection, as for example the surveying com-

(Continued from page 15.)

passes shown in the accompanying illustration. While these particular instruments are comparatively modern, being of the early nineteenth century, yet they antedate the general introduction of western ideas into Japan, so that their makers doubtless derived their inspiration from either Jesuit or Dutch East India Company influences. The manuscript shown in the background is one of a number of Japanese treatises on surveying belonging to Prof. Smith, in which the diagrams, often in color, are most artistically executed.

Returning from the East, our interest is attracted by a small wooden cylinder with vertical slits, which was used by the early Italian surveyors. It is known as a *squadra*, and could be mounted on a staff, where by sighting through its slits arranged at angles of 90 deg. and such other convenient angles as might be needed, it was possible to run the boundary lines of land. A common level used in the same fashion as the more modern gunner's quadrant, and placed on the breech of a cannon to determine the elevation, is a small but excellent piece of Italian make, while a German level of the eighteenth century suggests rather more closely modern surveying instruments. This tendency is even more evident in the German surveying instrument of the early nineteenth century, which lacking the telescope and compass has almost every essential feature of the modern transit or universal instrument, being designed for the measurement of both horizontal and vertical angles, and showing fine workmanship and accurate division of the circles.

The mathematician is always interested in weights and scales, for aside from the arrangement of various forms of weighing devices, the division of the weights themselves and the relation of the standards and units present many problems. Thus there are many scales and balances which show the various applications and modifications of the lever, and especially in the case of those belonging to primitive people they are valuable in bringing out the development in the art of weighing. The European weights, two nests of which are shown in the photograph with the Bavarian spring balance, were often of beautiful workmanship, and the subdivision was carried out with an accuracy that is most surprising.

The measure of time also finds an important place in the museum, for the calculation of the calendar in all religions was one of chief occupations of mathematicians, but especially in the early Christian church for the computation of Easter. The Buddhist temples of Japan were concerned with calendars quite as much as the Western Church, and their calendar rolls of the sixteenth and seventeenth centuries and other appurtenances show the attention paid to the subject on this side of the world. Accompanying the instruments themselves in most cases throughout the museum are to be found the contemporary authorities in book or manuscript; and while three of the earliest publications on the reform of the calendar by Pope Gregory supply first-hand information to the student in this field, there are also Chinese, Japanese, Hindu, Church Latin, and other manuscripts in addition to works in the tongues of mediæval and modern Europe for the investigator with such languages at his command. Prof. Smith has collected from East and West representatives of all the important forms of portable sundials, many of which exhibit artistic merit in their design and construction, besides considerable complexity in their arrangement. An interesting sundial from Peking is shown in the illustration, where, with its divided circles marked with Japanese characters, its compass, and other features, a number of points of interest are presented.

In a museum of mathematics there are of course to be found in plenty compasses, sectors, protractors, diagonal scales, and



Have you tried The 1909 Issue OF SCHULTZE OR NEW E. C.?

Their special qualities are STABILITY PERFECT PATTERNS EXCELLENT VELOCITY EASY ON THE SHOULDER

Shells loaded with either of these powders can be purchased through any dealer.

Send 12 cents in stamps for a set of six pictures illustrating "A Day's Hunt." Address Dept. T,

E. I. DU PONT DE NEMOURS POWDER CO. Wilmington, Del., U. S. A.

Wizard Repeating LIQUID PISTOL. Will stop the most vicious dog (or man) without permanent injury. Perfectly safe to carry without danger of leakage. Fires and recharges by pulling the trigger. Loads from any liquid. No cartridges required. Over six shots in one loading. All dealers, or by mail, 50c. Rubber-covered holster, 10c. With Pistol, 50c. Money order or U. S. stamps. No coins. PARKER, STEARNS & CO., 208 Sheffield Avenue, Brooklyn, N. Y.

SENSITIVE LABORATORY BALANCE. By N. Monroe Hopkins. This "built-up" laboratory balance will weigh up to one pound and will turn with a quarter of a postage stamp. The balance can be made by any amateur skilled in the use of tools, and it will work as well as a \$125 balance. The article is accompanied by detailed working drawings showing various stages of the work. This article is contained in SCIENTIFIC AMERICAN SUPPLEMENT, No. 1184. Price 10 cents. For sale by MUNN & CO., 361 Broadway, New York City, or any bookseller or newsdealer.

BARKER MOTORS. "Imitated, but Not Equalled" Fine mechanical features. Honest power ratings. Reasonable prices. Manufactured by C. L. BARKER, Norwalk, - - - Conn.

HOT BATH IN TWO MINUTES FOR TWO CENTS. Moses, by the aid of a rod, struck a rock and got cold water. You, by the aid of a HUMPHREY HEATER strike a match and instantly get hot water. Easily connected, simple, durable. Write for Booklet and 30 days Trial Offer. HUMPHREY CO., Dept. 426, Kalamazoo, Mich.

Free Catalogue of Scientific and Technical Books Free. We have just issued a new edition of our Catalogue of Scientific and Technical Books, which contains 144 pages, and a copy will be mailed free to any address on application.

MUNN & CO., Publishers of Scientific American 361 Broadway, New York

Table listing various scientific and technical items with prices. Items include: Cheese protector, F. J. Lindsay; Chimney, E. Bauzhar; Chloroform in solid condition; Chuck jaw, O. Parpart; Churn, E. E. Rippey; Churn dasher, J. B. Mellor; Chute, coal, H. M. Stradling; Cigar bunch molds; Circuit breaking device; Circuit wire connection shield; Clamp, Sinning & de Lange; Clamp, H. R. Schweinler; Clamp, Newton & Jourdan; Clamp and stretcher; Cleaner; Clothes hanger; Clothing case; Clutch, W. Dennis; Clutch, J. A. Sharp; Coating machine; Cock, ball, Weaver & Anderson; Cock or bit, compression; Cock, waste; Coin operated mechanism; Coke oven; Columns, mold for making fluted; Combination lock; Compound of the anthracene series; Concentrator; Concrete construction; Concrete floor; Concrete hog trough; Concrete reinforcing bar; Concrete structures; Concrete walls; Condensing apparatus; Condiment holder; Contact timer; Controller; Convertible chair; Conveyor; Cooker, feed; Cooking apparatus; Cooling device; Cores, ventilating means; Corking apparatus; Corn husking hook; Cornice piece; Cotton chopper; Cotton chopper; Cotton chopper; Cotton trapper; Coupling; Crane, power; Crate and coop; Crate, folding; Crate or box; Crate, shipping; Cross tie and rail fastener; Cuff holder; Cultivator; Curvants; Currycomb; Curtain draping apparatus; Curtain fixture; Curtain holder; Curtain stretcher; Cuspidor; Damper; Dentator; Dental plate casting apparatus; Derailing switch; Die maker's filing tool; Dish washer; Display tray; Door and like fastener; Door check; Door opening and closing mechanism; Doors, reversible supporting plate; Dough cutting device; Draft equalizer; Drain for counters; Drawing instrument; Drilling machine; Drive mechanism; Dust collector; Dust, pneumatic device; Eaves troughs; Educational device; Egg case filler; Electric apparatus; Electric cables; Electric current regulator; Electric kiln; Electric machine; Electric machine; Electric machine; Electric machines; Electric machinery; Electrical switchboard; Electroplating apparatus; Elevator; Elevator door guard; Elevator door opening attachment; End gate; Engine; Engines; Entrain cleaning machine; Envelop; Envelop and seal; Envelop, pocket; Equalizer; Eraser cleaner; Excavating and hoisting device; Excavating bucket; Fabrics, joining or connecting; Fabrics to render them adhesive; Fastening device; Faucet, quick closing; Feed bag supporter; Fellies, making wheel; Felly for wheels; Fence builder; Filter leaf; Filter or rainer; Filtering machine; Fire alarm, automatic; Fire escape; Fire plug; Fish trap; Flexible coupling; Fluid pressure brake; Fluid pressure regulator; Fly catcher; Fodder tie; Freezing apparatus; Frog; Fruit assorting or sizing apparatus; Rowland; Fruit gatherer; Funnel, automatic self-closing; Furnace door; Furnace door; Furnace pipe fitting; Furnaces, coke ovens; Funnel, automatic self-closing; Cheese protector, F. J. Lindsay 925.489; Chimney, E. Bauzhar 925.980; Chloroform in solid condition, preparation of, C. L. Schleich 925.658; Chuck jaw, O. Parpart 926.073; Churn, E. E. Rippey 925.653; Churn dasher, J. B. Mellor 925.932; Chute, coal, H. M. Stradling 926.032; Cigar bunch molds and releasing the bunches therein, apparatus for opening, J. R. Schmitt 925.600; Circuit breaking device, E. L. Rancourt 925.538; Circuit wire connection shield, T. E. Murray 925.823; Clamp, Sinning & de Lange 925.603; Clamp, H. R. Schweinler 925.669; Clamp, Newton & Jourdan 925.828; Clamp and stretcher, combined, C. Stout 926.030; Cleaner, See Eraser cleaner; Clothes hanger, H. C. Stanley 925.523; Clothing case, J. A. Cunningham 925.872; Clutch, W. Dennis 925.760; Clutch, J. A. Sharp 925.957; Coating machine, F. E. Goldsmith 923.059; Cock, ball, Weaver & Anderson 925.538; Cock or bit, compression, A. R. Bonfield, Jr. 925.679; Cock, waste, H. F. Schroeder 925.955; Coin operated mechanism, J. J. Wood 925.548; Coke oven, H. Koppers 925.815; Columns, mold for making fluted, J. P. Archdeacon 925.858; Combination lock, J. J. Deal 925.988; Compound of the anthracene series and making same, F. Kacer 925.917; Concentrator, W. M. Stover 926.031; Concrete construction, shear bar for reinforced, C. T. Lindsay 925.643; Concrete floor, J. McMillen 925.941; Concrete hog trough and valve, J. Robertson 925.948; Concrete reinforcing bar, E. Cunnings 925.750; Concrete structures, reinforcing means for, Boyle & Upton 925.989; Concrete walls, machine for making, A. J. Innes 925.912; Condensing apparatus, steam, D. A. Quiggin 925.506; Condiment holder, Dillon & Welsh 925.464; Contact timer, multiple, E. S. Lincoln 926.066; Controller, A. W. Cheney 925.995; Convertible chair, H. A. Britton 925.558; Conveyor, A. A. Lueke 925.928; Cooker, feed, L. D. Dewey, 2d 925.463; Cooking apparatus, H. A. Winterknight 925.672; Cooling device for rooms, D. F. Soliday 925.605; Cores, ventilating means for laminated, A. J. Brown 925.991; Corking apparatus, bottle, C. Sellenscheidt 925.518; Corn husking hook, R. N. Thomas 925.529; Cornice piece, A. J. Schoenecke 925.601; Cotton chopper, H. H. Hood 925.475; Cotton chopper, A. D. Beil 925.743; Cotton chopper, E. C. Gesche 925.768; Cotton trapper, automatic, E. H. Campbell 926.046; Coupling, H. S. Kutz 925.483; Crane, power, S. J. Webb 925.968; Crate and coop, folding, Jennings & Shuptrine 925.480; Crate, folding, C. E. Evans 925.628; Crate or box, B. K. Boyd 925.799; Crate, shipping, T. A. Redick 925.507; Cross tie and rail fastener, C. English 925.999; Cuff holder, L. Brigham 925.449; Cultivator, A. Helmlinger 926.063; Curvants, system for generating alternating, W. Stanley 925.607; Currycomb, G. M. Hubbard 925.637; Curtain draping apparatus, M. A. Tompkins 925.853; Curtain fixture, P. Raminger 925.829; Curtain holder and bracket, extension, G. A. Milholland 926.071; Curtain stretcher, J. Stawartz 926.081; Cuspidor, A. Eggenhofer 925.998; Damper, fireplace, W. R. Champion 926.048; Dentator or sanitary cuspidor, A. R. Mitchell 925.587; Dental plate casting apparatus, F. W. Tracy 926.037; Derailing switch, D. I. Hullett 925.774; Die maker's filing tool, Schrade & Conklin 925.954; Dish washer, J. W. Gallup 925.892; Display tray for merchandise, foldable, Faulk & Bratt 925.888; Door and like fastener, F. G. Parker, Sr. 926.018; Door check, W. W. Morey 925.821; Door opening and closing mechanism, F. Scott 925.956; Doors, reversible supporting plate for adjustable hanging strips for, L. S. Prentiss 925.505; Dough cutting device, A. Kimmel 925.919; Draft equalizer, E. Cook 925.461; Drain for counters, etc., E. C. Frost 925.574; Drawing instrument, spiral and circle, W. Brierley 925.748; Drilling machine, multiple, G. R. Rich 925.598; Drive mechanism, variable, S. B. Gray 926.060; Dust collector, F. J. Matchette 926.070; Dust, pneumatic device for collecting and removing, A. E. Moorhead 925.646; Eaves troughs, machine for making, W. J. Plicker 925.502; Educational device, H. T. McAnulty 925.716; Egg case filler, H. B. Collins 926.049; Electric apparatus, vapor, C. Bradway 925.620; Electric cables, fault locator for, Pennell & Hoffmann 925.594; Electric current regulator, H. A. Kelp 925.776; Electric kiln, Harper & Larkworthy 925.902; Electric machine, alternating current dynamo, W. Stanley 925.666; Electric machine, alternating current dynamo, B. Elshoff 925.884; Electric machine, dynamo, B. A. Behrens 926.086; Electric machine, high speed dynamo, A. H. Wouters 925.976; Electric machines, air drier for static, M. R. Farrar 925.887; Electric machinery, dynamo, Parsons & Law 925.499; Electrical switchboard for theatres, C. T. Waddell 925.732; Electroplating apparatus, Russ & Poland 925.599; Elevator, C. Devos 925.462; Elevator door guard, L. Christiansen 925.456; Elevator door opening attachment, A. E. Karg 925.918; End gate, C. S. Wright 925.739; Engine, See Caloric engine; Engines, apparatus for producing uniform fluid pressure for, E. Engelbreton 925.627; Entrain cleaning machine, L. Svoboda 925.527; Envelop, M. J. Shaffer 926.025; Envelop and seal, tag, J. H. Reeves, Jr. 925.597; Envelop, pocket, O. C. Sweet 925.730; Equalizer, W. H. Pickle 926.019; Eraser cleaner, blackboard, A. Bstrup 925.478; Excavating and hoisting device, W. Webster 925.794; Excavating bucket, W. C. Mitchell 925.588; Fabrics, joining or connecting, W. Keller 926.004; Fabrics to render them adhesive, treating, F. J. Gleason 925.894; Fastening device, E. A. Reeves 925.596; Faucet, quick closing, H. F. Schroeder 926.024; Feed bag supporter, triple, E. J. Colgan 925.624; Fellies, making wheel, M. Conrad 925.868; Felly for wheels with pneumatic tires, T. Bruckner 925.569; Fence builder, wire, W. S. Hazelton 925.905; Filter leaf, Blaisdell & Brooks 925.574; Filter or rainer, J. Truitt 926.038; Filtering machine, R. T. Wilder 925.856; Fire alarm, automatic, H. Furlani 925.575; Fire escape, Knapke & Lange 925.922; Fire plug, E. W. Smith 926.027; Fish trap, J. H. Wilson 925.972; Flexible coupling, Thomson & Rice 925.731; Fluid pressure brake, W. P. A. Macfarlane 926.068; Fluid pressure regulator, F. L. Jahn 925.812; Fly catcher, W. Weinfeld 925.616; Fodder tie, W. A. Koble 925.484; Freezing apparatus for concentrating solutions by, E. Monti 925.820; Frog, D. Salomone 925.728; Fruit assorting or sizing apparatus, H. K. Rowland 925.950; Fruit gatherer, J. W. Fahnestock 925.885; Funnel, automatic self-closing, Mathis & Brennan 925.931; Furnace door, F. S. Lang 925.486; Furnace door, O. Aube 925.444; Furnace pipe fitting, H. B. Eager 925.702; Furnaces, coke ovens, and the like from a distance, means for operating the doors of retort, P. Riecke 925.651

I. H. C. Gasoline Engines. embody the best mechanical principles and the materials and workmanship are always right. They have the approval of all mechanics. Dependable starters, smooth running, simple, economical. They deliver their full rating of power. STYLES AND SIZES FOR ALL USES Vertical in 2, 3 and 25 H. P. Horizontal (Portable and Stationary) 4, 6, 8, 10, 12, 15 and 20 H. P. Air-Cooled in 1 and 2 H. P. Call on our local agents for further information or write us for catalog. INTERNATIONAL HARVESTER CO. OF AMERICA (Incorporated) 15 Harvester Bldg., Chicago, U. S. A.

KEROSENE Boat Engines. as made by us, are practical, economical and extremely powerful. Use less than a pint of Kerosene or distillate per horse power an hour. There's more power per gallon in these cheap fuels than in Gasoline. You easily save \$15 to \$20 a season. DUBRIE MARINE MOTORS start easily and are always ready to go. They are QUALITY ENGINES—made to last indefinitely, without trouble, repairs or adjustments. Their dogged, "never-say-die" persistence has won many a contest against higher-powered motors. The price is reasonable. Ask for catalog and learn all about it. DUBRIE MOTOR CO., 421 Guolin St. Detroit, Mich. 1 Cylinder, 4, 6 and 9 h.p. 2 Cylinders, 8, 12 and 18 h.p. 3 Cylinders, 18 and 27 h.p.

Make a Motor Boat of any Boat in 5 Minutes. You can do it with the Waterman Outboard Motor which you can quickly attach (and detach) to the stern of any skiff, row boat, dinghy, punt, sail boat, and have a good motor boat. It is not a toy, but a reliable 2 H. P. Marine Motor that will drive an 18 foot row boat 7 miles an hour, 4 hours on gallon gasoline. Simplest motor made. Weight 40 lbs. Equipped with Schebler carburetor. Four years' successful results behind it. Send for Catalog C. Canoe Motors 1, 2, 3, 4 Cylinders—Catalog K. Standard Type Motors, 1 to 30 H. P.—Catalog A. WATERMAN MARINE MOTOR CO. 1509 Fort Street, West, DETROIT, MICH., U. S. A.

Schools and Colleges Electricity Practically Taught. through the medium of tools and machinery. Our students learn by doing the work themselves, under the guidance of skilled instructors, in the largest and best equipped Electrical School in the U. S. We prove our claims by showing all applicants through the school. Write or call for Prospectus "T." NEW YORK ELECTRICAL SCHOOL 39 West 17th Street New York City

Mackay School of Mines University of Nevada. Best equipped mining school in the country—all buildings of special construction. Faculty composed of prominent engineers and every department in charge of experienced instructors. Located close to great mining district—students obtain both wages and practical experience during vacations. Splendid climate—every opportunity for outdoor life amid beautiful surroundings. Summer school of Mine, Survey and Geology begins June 14th. (Seven weeks' course.) Regular term opens August 23rd. For detailed information address JOSEPH E. STUBBS, President Reno, Nevada

STUDY LAW. Leading Law School in Correspondence Instruction. Established 1892. Prepares for the bar, Three Courses: College, Post-Graduate and Business Law. Method of instruction combines theory and practice. Approved by the bench and bar. Classes begin each month. Send for catalog giving rules for admission to the bar of the several States. Chicago Correspondence School of Law 506 Reaper Block, Chicago

MY BOOK FREE "HOW TO REMEMBER" Sent Free to Readers of this Publication Stop forgetting. You are no greater Intellectually than your memory. Easy, inexpensive, increases income; gives ready memory for recreation; faces, names, business details, studies, conversation; develops will, public speaking, personality. Send today for Free Booklet. Address DICKSON MEMORY SCHOOL, 700 Auditorium Bldg., Chicago

LEARN WATCHMAKING. We teach it thoroughly in as many months as it formerly took years. Does away with tedious apprenticeship. Money earned while studying. Positions secured. Easy terms. Send for catalog. ST. LOUIS WATCHMAKING SCHOOL, St. Louis, Mo.

(Continued from page 16.)

other instruments, which, extending from Roman to Renaissance and later times, indicate very clearly the developments in this field, while the specimens of measures of length shown suggest most forcefully the chaotic conditions that but little more than a century ago prevailed in metrology, when every nation and almost every town had its individual and peculiar standards quite unlike the others except in having the same names. One of the measures well illustrating this condition is a brass Austrian ell standard of 1732, while the various gagers' scales show the debts that metrology and mensuration owe to the collection of excise taxes.

From the slates and possible abaci of the neolithic age in Egypt to the modern counting arithmometer of the accountant or professional calculator certainly is a far cry, but the steps are marked and are shown in this collection. In the beginning is a squeeze or impression from the Salamis abacus, the earliest one known, then the Chinese swan pan, the Japanese soroban, the Korean bones, the old Japanese sangi, the Russian stchoti, the Armenian abacus, and other similar forms, many of which still in use suggest the familiar frame and beads of the primary school. But by such schemes, slide rules, and more involved devices, artificial calculation has progressed to its present state.

The many readers of the SCIENTIFIC AMERICAN interested in magic squares perhaps will be surprised to learn that in the Yih King, one of the greatest Chinese classics, here shown in written manuscript on silk, is found the first trace of the magic squares attributed to Fuh Hi (B. C. 3322), the traditional founder of the nation, as well as of permutations, and possibly of binary numerals. Indeed, number mysticism as shown in the magic squares and like phenomena turns up in many interesting forms and places, as is shown here by plaster casts of inscriptions from Chittagong, India, and in more modern times in a reproduction of Dürer's "Melancholia," where is exhibited the oldest magic square known to exist in print. The magic squares by inscriptions and manuscripts may be traced in astrology, while some interesting Pali and Singhalese manuscripts on palm leaves show forms of its expression in India.

A collection of dice would seem hardly in place in an educational museum, but as the historical development of this game, which is one of the oldest if not the oldest of the many number games, can be traced over at least 3,000 years, it lends itself readily to exposition. And it is important further in that its influence in educating people in the use of numbers has been second only to the school. In Prof. Smith's collection we can view dice from Etruscan tombs, from the remains of the Persian invaders, from Karnak in Egypt, a divination eikosahedral piece of the Ptolemaic period, long dice of the Roman conquerors of lower Egypt, loaded dice of Rome, dice of Renaissance Europe, and so on to our own times.

The many medals of famous mathematicians here shown of themselves make a unique exhibition, with Newton honored by twelve different medals and others hardly less famous in proportion, and these with the original manuscripts, autographs, and portraits bring to the study of their works much that is personal. And we find the mathematicians of the East represented with those of the West, there being such documents as manuscripts of the work of Bhaskara, the greatest of native Hindu mathematicians, who flourished in the twelfth century, and whose work was influential both in India and the adjacent countries of Ceylon and Persia. There are facsimiles of the Ahmes and Akhmim Egyptian papyri, the former of which is the oldest manuscript extant, and not only dates from about 1700 B. C., but was copied from a treatise of about 2300 B. C. The interchange of ideas and the travel of mathematical science from the West to the East, only to be brought

(Concluded on page 19.)

FOR 148 YEARS

A. W. FABER has made the highest grade of lead pencils.

"CASTELL"

DRAWING COPYING INK PENCILS

represent that acme of perfection that can be obtained only by experience and long effort to produce the finest it is possible to manufacture.

Sold by all stationers and dealers in artists' and drawing materials. Samples worth double the money will be sent you on receipt of 10c.

A. W. FABER 49 Dickerson Street, Newark, New Jersey

PIONEER

SUSPENDERS

Give positive shoulder balance—direct, easy trousers support—comfort in every motion—longest service, greatest satisfaction—fine gilt mountings, artistic webs, elegance of finish. At dealers, 50c, or we mail them with our guaranty.

Brighton

GARTER

25¢

The Flattest Clasp
The Surest Grip
Pure Silk Web

All colors and fancy effects. At dealers, or we send direct, fully guaranteed.

PIONEER SUSPENDER COMPANY
718 Market St., Philadelphia
Makers of PIONEER BELTS

JAGER Marine

4-Cycle Engines

Skillfully designed and well built. Single lever control, combining automatic carburetor with spark advance. Develops wide speed range and reliability under most trying conditions. Sizes 3 to 60 h. p. Send for catalog.

CHAS. J. JAGER CO.
281 Franklin, cor. Battery March St.
Boston, Mass.

Automatic

Auto Wrench

LAKE SUPERIOR WRENCH CO. 500 ANK

Always ready to grip any fitting, pipe or nut, of ANY shape without adjustment. The harder you pull, the tighter it holds. Equal to half a machine shop in your tool-box. Twelve inch size takes everything up to 1 1/2 inch, \$1.00 prepaid.

GARAGES, DEALERS, AGENTS: We make nine sizes and have a splendid offer to make on this fast seller. Write us today.

Lake Superior Wrench Co., 321 Maple St., Sault Ste. Marie, Mich.

TOOLS

The 9th edition of our Catalog which we have recently brought out contains 272 pages. It illustrates and describes a large number of useful, labor-saving tools and light machines. It is free. Ask for one.

GOODSELL-PRATT COMPANY
GREENFIELD, MASS.

WELL DRILLING

MACHINES

Over 70 sizes and styles, for drilling either deep or shallow wells in any kind of soil or rock. Mounted on wheels or on rails. With engines or horse powers. Strong, simple and durable. Any mechanic can operate them easily. Send for catalog.

WILLIAMS BROS., Ithaca, N. Y.

ANYTHING ELECTRICAL

JUST OUT.—A 3c. stamp will secure our New Big Catalog. Positively the most comprehensive of its kind published. Twenty-five pages of Experimental and Higher Grade Wireless Apparatus Alone.

J. J. DUCK, Arcade Building, Toledo, Ohio

ELECTRO MOTOR. SIMPLE, HOW TO

make.—By G. M. Hopkins. Description of a small electric motor devised and constructed with a view to assisting amateurs to make a motor which might be driven with advantage by a current derived from a battery, and which would have sufficient power to operate a foot lathe or any machine requiring not over one man power. With 11 figures. Contained in SCIENTIFIC AMERICAN SUPPLEMENT, No. 641. Price 10 cents. To be had at this office and from all newsdealers.

SETS OF CASTINGS OF

MODEL ENGINES

SEND 10¢ FOR 126 PAGE ILL. CATALOGUE.

ALSO TOOLS, GEAR WHEELS, & PARTS OF MODELS

GOODNOW & WIGHTMAN

Removed to 182 Milk Street.

THE BEST EQUIPPED SHOP

For Mechanical and Electrical Manufacturing

Special Machinery, Jigs, Tools, Repairs, Experimental Devices

Designing and Commercializing a Specialty

THE ROWLAND TELEGRAPHIC COMPANY, Baltimore, Md.

Chicago Beach Hotel

— Finest Hotel on the Great Lakes —

An ideal resort for rest or pleasure—ten minutes' ride from city, close to the famous Golf links and other attractions of the great South Park System. Has 450 large airy rooms, 250 private baths. There is the quiet of the lake, beach and shaded parks, or the gaiety of boating, bathing, riding or driving, golf, tennis, dancing and good music. Table always the best. Nearly 1000 feet of broad veranda overlooking Lake Michigan. For handsomely illustrated booklet address Manager, 51st Blvd. and Lake Shore, Chicago

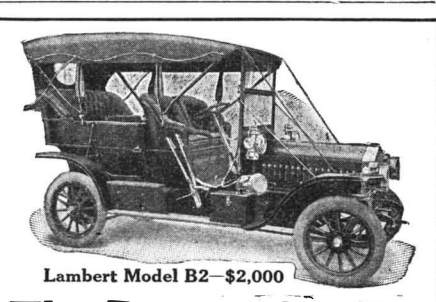

Lambert Model B2—\$2,000

The Proven Quality

which buyers of big cars demand is found in the 7-passenger Lambert Model B2, and at a price most buyers would prefer to pay. This handsome, roomy, powerful car has every bit of automobile worth we can put into it. If our price were \$3,000 the car wouldn't be any better. It's a **satisfaction** car from motor to tail lamp.

Model B2 has 4-cylinder Rubenber Motor with adjustable fan attached; 35-40 H. P.; speed 1-45 miles per hour; Lambert friction (most efficient) transmission; direct chain drive to each rear wheel; wheel base, 106 inches; 32" x 4" pneumatic quick detachable tires; painted imperial green, striped with carmine; cape extension; top, with full set storm curtains; liberal equipment of accessories and full tool kit.

Each of our six Lambert models has a full dollar's worth of power, speed, endurance, style and finish for every dollar of the price—and more too, if judged by ordinary standards.

Write for fully descriptive illustrated catalogue.

BUCKEYE MANUFACTURING CO.
1814 Columbus Ave., Anderson, Ind.

— EVERY 1910 —

Pierce Arrow

Will be Equipped at the Factory
With the Famous

Truffault Hartford Shock Absorber

"THE STANDARD OF THE WORLD"

This will make the sixth consecutive year that these celebrated cars have been Truffault-Hartford equipped.

More than 20 other prominent automobile manufacturers make the Truffault-Hartford Shock Absorbers part of their standard equipment. What better proof do you want that they should be on your car?

HARTFORD SUSPENSION COMPANY
EDW. V. HARTFORD, President
160 Bay Street, Jersey City, N. J.

BRANCHES: New York, 212-214 West 88th Street,
Boston, 319 Columbus Avenue.

MARSTON'S

Patent Hand Foot & Power
Circular & Band Saw

Send for Catalogue

J. M. MARSTON & CO.
247 Ruggles St., BOSTON, MASS.

Send for Bulletin No. 1557

The Holtzer-Cabot

Jump Spark Magneto

Double Brush Rigging, Heavy Shaft, Automatic Lubrication. Efficient, Simple and Rugged.

THE HOLTZER-CABOT ELECTRIC CO.
Boston (Brookline), Mass.
Chicago, Ill.

Incorporate and **BUSINESS** in **ARIZONA**

Laws the most liberal. Expense the least. Hold meetings, transact business anywhere. Blanks, By-Laws and forms for making stock fully-paid for cash, property or services, free. President Stoddard, FORMER SECRETARY OF ARIZONA, resident agent for many thousand companies. Reference: Any bank in Arizona

STODDARD INCORPORATING COMPANY, Box 8000
PHOENIX, ARIZONA

Furnaces for boilers, etc., burning fuel in.	925,632
C. M. Gurnee	925,632
Furnaces, refining of steel in electric, O. Thallner	925,632
Fuse plug, A. Weber, Jr.	925,632
Gage, S. G. Ryder	925,632
Game apparatus, Tutbill & Von Wormer	925,534
Garbage and rendering apparatus, C. S. Wheelwright	925,970
Garbage, extracting grease and oil from, C. S. Wheelwright	925,971
Garment supporter or hanger, J. K. Druttman	925,997
Gas, capsule for holding compressed or liquefied, Read & Campbell	926,075
Gas holders, guide frame for, H. J. Stoffels	925,850
Gas producer, L. F. Burger	925,621
Gas producer, G. Hatton	925,634
Gases and vapors, apparatus for administering, G. von Ach	925,442
Gases, composition for oxidizing and purifying explosion, H. Walker	925,670
Gaseous fuel burners, lighting attachment for, C. E. Heft	925,808
Gate, G. W. Traxler	925,668
Gate, F. Adams	925,977
Gate, H. P. Liles	926,010
Gearing, E. C. Gesche	925,769
Geography, illustrator, mathematical, W. H. Keller	926,064
Glass articles, making pressed, O. A. Mygatt	925,824
Glass furnace, H. Brooke	925,864
Go-cart or baby carriage, A. J. Adams	925,741
Gradients, means for and method of determining potential, W. Stanley	925,606
Grate, J. & W. Reagan	925,787
Grate, shaking, J. & W. Reagan	926,076
Grinding machine, multispindle metal, W. L. Bryant	925,867
Grinding mill, Beck & Kramer	925,987
Grinding wheel, G. E. Soper	925,848
Grindstone attachment, J. Sylvestre	925,610
Gun, automatic, Dawson & Buckham	926,052
Gun firing mechanism, A. Y. Leach, Jr.	925,642
Gun rammer, Meigs & Stout	925,819
Hame fastener, P. W. Napierala	925,497
Hame tugs, metallic loop for, E. H. Gulliom	925,898
Harmonica, R. L. Lanier, Sr.	925,778
Harvester conveyer, Anderson & Quesnell	926,043
Harvester, corn, J. A. Stone	925,526
Harvester, corn, Butler & Wideman	925,749
Harvester reel attachment, A. M. Somichsen	925,664
Harvester stripper, O. A. A. Rand	925,945
Hat bodies, machine for clipping blocked, J. H. Starr	925,608
Hat ventilator attachment, F. R. Skidmore	926,004
Hay press, F. A. Ryther	925,514
Heat of combustion and steam power in prime movers, utilizing, T. Shtscherbakoff	925,845
Heating apparatus, hot air forming and feeding device for, J. Eckert	925,570
Heating system, convertible, E. H. Gold	925,806
Heel plate, E. Frank	925,690
Hinge, H. E. Hoke	925,910
Hinge mechanism for windows, etc., T. I. Duffy	925,568
Hinge, spring, H. W. Steele, reissue	12,978
Horse controlling device, L. E. V. Cullinger	925,873
Horseshoe and pad, combined, B. P. Gray	925,631
Horseshoe, emergency, Belloff & Roth	925,982
Hose coupling, H. P. Magone	925,713
Hose coupling, E. W. Smith	925,959
Hose supporter, J. F. Stoldt	925,948
Household utensil, S. D. Smith	926,028
Igniter, electromagnetic, C. S. Beardsley	925,742
Indicator, H. H. Shults	926,026
Imitation device, E. De Moulin	925,878
Internal combustion engine, L. E. Fish	925,766
Internal combustion motor, C. H. Atkins	925,793
Jack spools, holding means for, L. T. Houghton	925,811
Joint. See Rail joint.	
Kitchen utensil, J. S. Grenn	925,695
Ladder, extension, H. & L. Mote	925,822
Ladder, jointed, L. W. Rentrow	925,598
Lamp burner for incubators, W. S. Ault	926,044
Lamp construction, W. Herwig	925,771
Lamp, incandescent, C. C. Woodworth	925,790
Lamp receptacle, multiple cluster, F. S. Ober	925,830
Lamp shade, W. J. Gray	925,897
Lamp, vehicle, H. W. Beebe	925,676
Lamp, vehicle, J. K. Punderford	925,720
Lamps, adjustable support for vapor, S. E. Flichtner	926,057
Lamps, supplemental light for, Taylor & Elkins	926,082
Lamps, treating metallic filaments for electric incandescent, W. Majert	926,069
Land roller, pulverizer, and seed planter, combined, V. D. Curtis	925,565
Lantern, beacon or anchor, F. P. Coulter	925,563
Lasting machine, Roberts & Ward	925,511
Latch, gate, T. Dailey	925,874
Lawn trimmer, C. E. Waters	925,671
Lenses, producing bifocal, C. W. Conner	925,802
Letter box, J. A. Steinmetz	925,524
Letter trying device, B. P. Greenwood	925,684
Line casting machine, R. G. Clark	925,753
Line casting machine, J. R. Rogers	925,843
Line casting machines, etc., keyboard mechanism for, J. R. Rogers	925,844
Linotype machine, F. B. Converse	925,754
Linotype machine, J. R. Rogers	925,842
Lock, P. S. Dunn	925,761
Lock, Faust & Hogland, reissue	12,977
Lock and fastening, J. S. Campbell	925,455
Locking detachable joint, B. Rothschild	925,654
Locomotive cylinders, planer for, W. J. Hagman	925,696
Logging grab, W. P. Smith	925,961
Loom, automatic filling replenishing, Northrop & Wood	926,015
Loom shuttle, J. Northrop	926,017
Loom shuttle, automatically threading, J. Northrop	926,016
Loom starting and stopping mechanism, A. E. Rhoades	926,021
Looms, weft cutting mechanism for weft replenishing, J. Gabler	925,891
Lunch box, P. J. Bird	925,447
Machine knives and making the same, composite stock for, P. Searle	925,661
Magnet, H. Rutshard	925,951
Mail catching and delivering apparatus, J. Wood	925,618
Mail handling apparatus, pneumatic, Riggle & Baker	926,078
Mail loader, T. B. Modlin, et al.	925,493
Mail receiving and delivering apparatus, A. D. Wack	925,966
Marble shooter or gun, J. A. Radebaugh	925,944
Marking machine, G. C. Kutz	925,923
Match box, F. E. Laffer	925,485
Match box, L. C. Lang	925,487
Match holder, W. A. Smith	926,029
Match receptacle and igniter, combined, E. Lamprecht	925,924
Measuring glass, A. Kipp	925,582
Measuring instrument, J. Green	925,807
Mechanical movement, D. K. Wilson	925,547
Mechanical movement, A. P. Crell	925,564
Medicament, producing a, W. D. Neel	925,590
Merry-go-round, aquatic, H. E. Riehl	925,840
Metals from ores and other substances, apparatus for recovering, L. Dixon	925,626
Metals of a highly refractory nature, apparatus for producing homogeneous ductile bodies from, W. von Bolton	925,798
Microphone, H. R. Stuart	925,609
Mines, trap door for, V. A. & H. Johnson	925,915
Minnow, artificial, W. G. Kahlo	925,482
Mixer. See Mortar mixer.	
Molding apparatus guides, forming, Danver & Lose	925,686
Molding apparatus guiding device, Danver & Lose	925,687
Molding hollow articles in sand by means of divided patterns, E. & T. Refsum	925,724
Mop, C. H. Davis	925,758
Mop wringer, W. P. Scheets	925,657
Mortar mixer, P. L. Blystone	925,744
Motor, Barnes & Schmitt	925,860
Motor controlling mechanism, L. Roberson	925,653
Mower track clearer, G. Braun	925,863
Multiple drill, H. E. Hawes	925,474
Music rack, J. C. Dillon	925,465

Classified Advertisements

Advertising in this column is 75 cents a line. No less than four nor more than ten lines accepted. Count seven words to the line. All orders must be accompanied by a remittance. Further information sent on request.

READ THIS COLUMN CAREFULLY.—You will find inquiries for certain classes of articles numbered in consecutive order. If you manufacture these goods write us at once and we will send you the name and address of the party desiring the information. There is no charge for this service. In every case it is necessary to give the number of the inquiry. Where manufacturers do not respond promptly the inquiry may be repeated.

MUNN & CO.

BUSINESS OPPORTUNITIES.

A LARGE MANUFACTURING COMPANY with exceptionally fine metal and wood working facilities, are interested in securing a good specialty to add to their present line. Owners of ideas, whether wholly developed or not, may find it to their advantage to communicate with us at once. Address Specialty, Box 773, N. Y.

PATENTS FOR SALE.

FOR SALE.—Outright or royalty. Shutter hinge. Shutter cannot be blown shut or rattled by strong winds. Does away with the old-fashioned turn-buckle. United States patent No. 890,547. Canadian patent No. 112,866. Non-refillable bottle. United States patent No. 905,485. Simple, cheap and practical. For further information and full particulars address E. Witman, Jr., Wernersville, Pa.

Inquiry No. 8868.—Wanted to buy nickeloid for buttons.

FOR SALE.—Patent on gas drop light. Will be issued June 29. Just what the market is looking for. For particulars address C. M. Pital, Meriden, Conn.

Inquiry No. 8904.—Wanted to buy new or second hand machinery for making bow type, mouse and rat trap springs and wire parts, single machine or full outfit.

FOR SALE.

FOR SALE.—Specialty for manufacturers. Dental boss holder, patented May, 1908. For further particulars apply direct to inventor, T. A. Tubbs, Seattle, Wash., care H. S. Emerson Company.

Inquiry No. 8908.—For a dealer in tapes and cords for Venetian blinds.

FOR SALE by private Treaty, a small collection of Fine Editions of Early Scientific Works, comprising Luce de Burgo, 1494; Cardan, 1555; Tartaglia, 1566; Vieti, 1615; Euclid, 1570; Gilbert, 1600; Kepler, 1609; Copernicus, 1543, etc. Address Box 5783, care Willings, 125, Strand, London, W.C., England.

Inquiry No. 8918.—For manufacturers of "Wyd's Electro-Catalytic Sparking Plug."

Inquiry No. 8921.—For the manufacturers of gilt paper.

HELP WANTED.

LOCAL REPRESENTATIVE WANTED.—Splendid income assured right man to act as our representative after learning our business thoroughly by mail. Former ability, ambition and willingness to learn a lucrative business. No soliciting or traveling. This is an exceptional opportunity for a man in your section to get into a big paying business without capital and become independent for life. Write at once for full particulars. Address E. R. Marden, Pres., The National Co-operative Real Estate Company, Suite 373, Marden Building, Washington, D. C.

Inquiry No. 8922.—Wanted the address of Worthington Boiler Co.

PARTNERS WANTED.

WANTED. PARTNER to invest \$10,000 to manufacture a new and successful electric clock, made at small cost, attached to electric light or power circuit. One master clock controls 200 clocks. For office buildings, court houses, etc. Principals only. Address Frank B. Andrews, 409 Superior Ave., N. W., Cleveland, O.

Inquiry No. 8928.—For the manufacturers of a steam rotary excavator as described in the Scientific American of December 12, 1908, page 347.

LISTS OF MANUFACTURERS.

COMPLETE LISTS of manufacturers in all lines supplied at short notice at moderate rates. Small and special lists compiled to order at various prices. Estimates should be obtained in advance. Address Munn & Co., List Department, Box 773, New York.

Inquiry No. 8931.—For parties who manufacture the Western Stump Borer for boring stumps.

Inquiry No. 8936.—Wanted machinery used to spin or wrap paper pencils in the manner that paper pencils are made.

A LIST OF 1,500 mining and consulting engineers on cards. A very valuable list for circularizing, etc. Price \$15.00. Address Munn & Co., List Department, Box 773, New York.

MISCELLANEOUS.

TOBACCO HABIT CURED OR NO COST. Harmless home treatment. Ni-Lio Rem. Co., Wichita, Kansas.

Inquiry No. 8941.—For manufacturers of machinery for making fly screens.

Inquiry No. 8957.—Wanted manufacturers of angle bars either malleable steel or sheared.

Inquiry No. 8960.—For the address of the Windsor Mfg. Co., manufacturers of waterproof collars and cuffs.

Inquiry No. 8966.—Wanted the address of the Cohendet Motor Co.

Inquiry No. 8969.—Wanted machines that make accordion dress plating (steam).

Inquiry No. 8972.—Wanted to buy complete outfit for making meat hooks.

Inquiry No. 8974.—For address of firms interested in fishing reels.

Inquiry No. 8975.—Wanted the address of the builders of moving stair cases.

Inquiry No. 8977.—For manufacturers of machinery for manufacturing denatured alcohol.

Inquiry No. 8978.—Wanted the address of manufacturers of dry pans or crushers to grind sand for plastering and cement works.

Inquiry No. 8980.—For the address of manufacturers of mortars and pestles that are used by druggists.

Inquiry No. 8982.—Wanted a machine or process for slitting or laminating the edges of heavy cardboard, impregnating the slit or laminated edge with a waterproof material and compressing the edge after treatment. The object of the process is to produce an edge that shall be waterproof and which shall not fray or split when in use.

Inquiry No. 8984.—Wanted the address of the manufacturers of Cypress wash tubs.

Inquiry No. 8986.—Wanted to buy crown and flint glasses for telescope objectives.

Inquiry No. 8987.—Wanted, the manufacturers of the Van Winkle, Woods & Sons, and the Weber power meters.

Inquiry No. 8989.—Wanted a machine for making cocoa fiber mats.

Inquiry No. 8990.—For information regarding shoes not made of leather but similar to the same and are as durable.

Inquiry No. 8991.—Wanted to communicate with manufacturers of large straw hats for every-day wear.

Inquiry No. 8993.—Wanted to buy producer gas plants.

Inquiry No. 8994.—For manufacturers of an apparatus to produce very high temperatures.

Inquiry No. 8995.—Wanted to buy round and oval glass paper weights, such as are used for mounting photographs.

Inquiry No. 8996.—Wanted addresses of manufacturers of machinery for working orange wood manure sticks.

Inquiry No. 8997.—Wanted the address of the manufacturers of bread or cake boxes.

Inquiry No. 8998.—Wanted an automatic snap, ball and socket or other device which can be used easily and securely to fasten together the edges of small wooden boxes.

Table listing various mechanical and scientific items for sale or inquiry, including musical instruments, pumps, and machinery parts.

Practical and Instructive Scientific Books

Extensive list of scientific books categorized by subject (Agriculture, Alcohol, Amusements, etc.) with descriptions and prices. Includes titles like 'The New Agriculture', 'Compressed Air', and 'Electricity'.

Please mention the SCIENTIFIC AMERICAN when writing to advertisers

(Concluded from page 17.)

back again to Europe by the Arabs, is strikingly illustrated in an Arabic manuscript of the famous mathematician of Alexandria, Euclid, the father of geometry, which dates from about 1300 A. D., and is thought to be the oldest surviving manuscript of this great work. But Euclid went even to China, and Prof. Smith has a Chinese translation by Matteo Ricci, written about 1600.

With the revival of learning in Europe the Arabic manuscripts were translated into Latin, and there are in the collection several editions of the fifteenth and sixteenth centuries. With a brief reference to the casts of the Babylonian mathematical tablets found at Nippur, and original cylinders with mathematical inscriptions in cuneiform characters, it is only possible to mention further the material accumulated for the study of the growth of various number systems, especially among the Hindus, Arabs, Greeks, Romans, and Chinese. This is shown in the reckoning counters, in the money, in strings of beads for ornament and for religious use, and in various commonplace articles, where the growth of the realization of numbers and the development of the number sense is typified.

It would indeed be harder to find a more impressive or direct way of demonstrating the part that mathematics has played in the development of civilization and knowledge than by a study of Prof. Smith's unique collection, which appeals with quite as much force to the casual observer as to the student of mathematical science.

Insect Powder.

Dalmatian or Persian insect powder consists of the dried and pulverized flowers of two species of chrysanthemum (sub-genus *Pyrethrum*) of which one grows wild in profusion on the snowy mountain slopes of Montenegro and the neighboring districts of Albania, Dalmatia, Herzegovina, and Italy. The other species is a native of Asia Minor. The exportation of pyrethrum powder from Montenegro began in 1865. The price was very high, exceeding one dollar per pound until the cultivation of the plant was commenced in Dalmatia.

Extensive plantations were made in California in the eighties, in consequence of which the price of the powder in the United States fell suddenly to about 8 cents per pound. It was soon discovered, however, that the cultivation of pyrethrum in California diminished its potency, and the price of the European product rose in consequence of a renewed demand from America.

The best time to pluck the flowers is in the latter part of May, when they are just opening and possess greater insecticidal power than in the fully expanded condition. The flowers are bought by dealers, who dry them, obtaining one pound of dried from four pounds of fresh flowers. Nine or ten tons of the dried flowers are annually exported from Montenegro. Formerly they went almost exclusively to Trieste, whence they were distributed to Venice, Vienna, Budapest, and Berlin, where they were pulverized. In recent years an English firm in Podgoritz has been endeavoring to capture the entire crop for a firm in New York. This firm bought 5 tons in 1906, and 7 tons in 1907. The flowers destined for America go first to London, where they are pulverized. In consequence of this attempt to corner the market the price has risen from 26 to 49 cents per pound.

For some purposes pyrethrum has been largely superseded by naphthalin, but pyrethrum powder is still employed extensively and effectively for the destruction of insects in the house and on the farm. The Montenegrin product is the best, probably because of the dry and cloudless summers of Montenegro. Even the stalks of the Montenegrin plants are said to furnish as strong a powder as the flowers produced in other countries.—Prometheus.

Sieve, adjustable, C. Cloz.....	925,623
Sight testing apparatus, J. H. Tomlinson.....	926,035
Sign exhibitor and display rack, E. G. & G. H. Cuny.....	925,757
Sign, revolving, M. Helm.....	925,907
Sky rocket, A. L. Due.....	925,577
Sleeve protector, H. Sacks.....	925,952
Slipper package, M. Woodbury.....	926,041
Snow plow, W. J. McFarland.....	925,717
Snow shovel, R. Wolf.....	925,789
Soap dispensing apparatus, liquid, Frank & Venners.....	925,629
Soap holder, W. M. Parker.....	925,943
Sole leveling machine, J. H. Rigby.....	925,509
Sound reproducer, R. B. Smith.....	925,846
Speedometer, J. H. Bullard.....	925,992
Speedometer indicators, etc., maximum hand for, J. W. Jones.....	925,814
Spike puller, E. F. Bramstadt.....	925,557
Splint holding frame, W. H. Parker.....	925,592
Stacker, hay, D. R. Long.....	925,816
Stapling machine, A. R. Tiffany.....	925,531
Steam regenerative apparatus, L. P. L. Battu.....	925,797
Steam trap, A. D. Horne.....	925,773
Steeping apparatus, A. W. H. Lenders.....	925,583
Steering gear, gyroscopic, F. M. Leavitt.....	925,709
Step, extension, E. F. Howell.....	925,476
Step switch, regulating, B. M. McInerney.....	925,495
Stock salting device, B. R. Bonney.....	925,539
Stoker, mech., J. & W. Reagan.....	925,723
Stone sawing machine, G. L. Fuller.....	925,767
Stone working tool, G. N. Williams, Jr.....	925,546
Stop, non-reversing, R. J. Moulton.....	925,715
Stove, regenerative, A. C. Nelson.....	925,827
Strainer, liquid, A. Schwieger.....	925,517
Strap, S. F. Blackburn.....	925,988
Sulfur, etc., from furnace gases, obtaining, F. R. Carpenter.....	925,751
Suspension of high tension lines, Buck & Hewlett.....	925,561
Swingletree, M. M. Wheeler.....	925,735
Switch, G. W. Hart.....	926,001
Talking machine sound modifier, E. P. Shepard.....	925,958
Tank safety device, pressure, H. C. Hanson.....	925,699
Tantalum, hardening, W. von Bolton.....	925,988
Target, H. C. Peffer.....	925,785
Target, F. J. Johnston.....	926,003
Telegraph key, L. Wilson.....	925,737
Telegraph transmitter, C. W. Leiser.....	925,925
Telephone exchange system, W. A. Fricke.....	925,573
Telephone transmitter appliance, Hutton & Ellis.....	925,775
Telephone transmitter appliance, O. H. Goodrich.....	925,806
Telephony, G. C. Cummings.....	925,756
Thimble, B. C. Callender.....	925,801
Thimble, T. Weigle.....	926,040
Thresher, traveling, G. O. Walters.....	925,967
Tide and wave motor, C. S. Kendall.....	925,581
Tile press mold, W. P. Meeker.....	925,782
Timer, F. A. Putnam.....	925,649
Tire, C. H. Keffler.....	925,589
Tire, elastic vehicle, C. Motz.....	925,937
Tire, elastic vehicle, C. A. Motz.....	926,012
Tire patch, J. A. Wheeler.....	925,969
Tire, vehicle wheel, G. W. Lilley.....	925,711
Tire, wheel, J. D. Marvill.....	925,930
Tire, wheel, A. Birnbaum.....	925,985
Tobacco cutting machine, R. E. Rosewarne.....	925,512
Tobacco stick holder, A. B. Lewis.....	925,585
Toilet article, J. Babst.....	925,675
Tool holder, friction, B. F. Vickery.....	925,854
Top, double, E. V. Guillaume.....	926,033
Torpedo, E. P. S. Andrews.....	925,857
Torpedo launching device, S. Lake.....	925,707
Torpedo steering mechanism, F. M. Leavitt.....	925,710
Torpedoes, turbine installation for, S. Z. de Ferranti.....	925,889
Towel rack, B. S. Gruner.....	925,473
Toy bank lock, C. Hansen.....	925,900
Toy top, J. A. Irving.....	925,479
Track brace, M. P. Bardou.....	925,981
Tracker bar, J. J. Kellin.....	925,777
Train stopping mechanism, J. F. Webb, Jr.....	925,733
Transits, and hand levels, attachment for engineers, F. W. Austin.....	925,674
Transom and window operating mechanism, F. A. Bickley.....	925,555
Tree. See Shoe tree.	
Trestle, paper hanger's folding, F. H. Skinner.....	925,520
Trick platform, E. De Moulin.....	925,877
Trolley attachment, F. V. Polakoskey.....	926,020
Trolley holding and retrieving device, J. W. Woodward.....	925,549
Truck, F. W. C. Bailey.....	925,705
Truck, fodder binding, W. A. Forbes.....	925,470
Truck, motor, A. Christianson.....	925,682
Trunk or package binder, J. E. Embry.....	925,763
Truss, C. Molz.....	925,645
Tungstic anhydrid, purifying, E. P. Beckwith.....	926,084
Turbine, E. I. Braddock.....	925,556
Turnbuckle, W. Hardick.....	925,901
Type bar, E. E. Tallaferrro.....	925,852
Type casting machine, W. H. Brueckmann.....	925,866
Typewriter adding machine attachment, L. M. Danie.....	925,685
Typewriter ribbon positioning device, G. Trejo.....	926,036
Typewriting machine, E. Thurey.....	925,530
Typewriting machine, J. H. Barr.....	925,796
Typewriting machine, J. C. McLaughlin.....	926,014
Typewriting machine, F. A. Cook.....	926,050
Typewriting machine, J. C. Doane.....	926,054
Typewriting machines, paper directing attachment for, B. P. Gibbs.....	925,576
Valve, E. H. Gold.....	925,692
Valve, G. Speer.....	925,725
Valve actuating mechanism, G. B. Petsche.....	925,836
Valve, gate, W. W. Doolittle.....	925,880
Valve operating mechanism, electrically controlled, H. W. Zook.....	925,673
Valve operating mechanism, flush, Young & Robertshaw.....	925,550
Vapor burner, W. Tuppstedt.....	925,965
Vegetable cutter, J. P. Spacek.....	925,663
Vegetable cutter, Goodykoontz & Byrne.....	925,693
Vehicle brake, J. H. Wesson.....	925,543
Vehicle pneumatic brake, motor, E. B. Sweet.....	925,528
Vehicle running gear, M. W. Heyenga.....	925,579
Vehicle running gear attachment, Abrams & Mason.....	925,740
Vehicle wheel, J. M. Page.....	925,498
Vehicle wheel, road, J. Henderson.....	925,908
Vending apparatus, H. J. Potter.....	925,595
Vending machine, E. B. Shanks.....	925,682
Vessel, submarine, S. Lake.....	926,065
Vessels, navigating turret for submergible, S. Lake.....	925,706
Violin support, E. R. Johns.....	925,481
Wagon brake, automatic, H. J. Williams.....	925,617
Washing machine, rotary, H. Stitzel.....	925,525
Water heater, E. A. Peterson.....	925,501
Water wheel gate controlling mechanism, A. Reid.....	925,839
Waterer, stock, P. Bernard.....	925,984
Way bill, F. H. Crump.....	925,871
Well drilling machine, Smith & Sanford.....	925,960
Wheel attachment for dragging logs and heavy loads, J. H. Long.....	925,780
Wheel bearing mechanism, vehicle, G. F. Umholtz.....	925,536
Whip socket lock, J. B. Hollenbeck.....	925,635
Windmill regulator, A. D. Dusenbery.....	925,569
Window fixture, Girouard & Perron.....	925,893
Window lift and lock, combined, I. Johnson.....	925,914
Windows, etc., apparatus for cleaning, F. A. Wible.....	925,788
Wire fabric making machine, A. L. Kitzelman.....	925,639
Wire polishing machine, H. Janssen.....	925,602
Wrench, R. M. Ryan.....	925,513
Wrench, N. S. Stalker.....	925,522
Wrench rack, C. A. Gordon.....	925,577

A printed copy of the specification and drawing of any patent in the foregoing list, or any patent in print issued since 1863, will be furnished from this office for 10 cents, provided the name and number of the patent desired and the date be given. Address Munn & Co., 361 Broadway, New York.

Canadian patents may now be obtained by the inventors for any of the inventions named in the foregoing list. For terms and further particulars address Munn & Co., 361 Broadway, New York.

The Yellowstone and Other Western Trips

A VERY attractive variety of low-fare tours through the West and Northwest may be made this year, including tours through Yellowstone Park, a trip to the Alaska-Yukon-Pacific Exposition at Seattle, through Colorado and California. You will add greatly to the comfort of your journey by *insisting* that your railroad and sleeping car tickets read via the

Chicago Milwaukee & St. Paul Railway

A few of the numerous Western trips offered, together with railroad fare from Chicago, are shown below:

Yellowstone Park Tours

\$44 round trip from Chicago to Yellowstone Park, daily until September 22d. Return limit, October 31st. Choice of routes. Fourteen different tours at various rates are offered through the park. Stop-overs.

Round Trip to Colorado

\$30 round trip from Chicago to Denver, Colorado Springs or Pueblo, daily until September 30th. Return limit, October 31st. Choice of routes. Stop-overs.

Alaska-Yukon-Pacific Exposition

\$62 round trip from Chicago to Seattle, daily until September 30th. Return limit, October 31st. Choice of routes. Stop-overs.

\$62 round trip from Chicago to Tacoma, Spokane, Portland, Victoria, Vancouver, Butte and other points. Same dates of sale, etc.

To CALIFORNIA

\$62⁵⁰ from Chicago to San Francisco, Los Angeles and San Diego, June 24th to July 10th and July 27th to August 6th.

\$72⁵⁰ round trip, daily until September 30th. Return limit, October 31st. Choice of routes. Stop-overs.

\$62 for a combination trip through the West, as follows: Chicago to Seattle, via St. Paul and Minneapolis, for the Exposition; stop-over at Yellowstone Park; returning via Portland and through Colorado to Chicago via Omaha or Kansas City. You may reverse these routes, if desired. Cost of railroad ticket for this trip, **\$62**, for the round trip.

Complete information about railroad fares, routes, train service and descriptive literature free on application.

F. A. MILLER
General Passenger Agent
CHICAGO

GEO. A. BLAIR
General Eastern Agent
381 Broadway, N. Y. City

DON'T LET YOUR PATENT LIE IDLE. We'll make dies and tools and manufacture your article ready for market. Write now—don't delay. Southern Stamping & Mfg. Co., R. 8., Nashville, Tenn.

ICE MACHINES Corliss Engines, Brewers' and Bottlers' Machinery. THE VILTRIK MFG. CO., 899 Clinton St., Milwaukee, Wis.

MODELS & EXPERIMENTAL WORK. Inventions developed. Special Machinery. E. V. BAILLARD CO., 24 Frankfort Street, New York.

RUBBER Expert Manufacturers Fine Jobbing Work PARKER, STEARNS & CO., 288-290 Sheffield Av., B'klyn, N. Y.

MOORE & CO. Special Machinery, Dies, Tools, Models. Metal Specialties, Inventions perfected. Indiana and Franklin Streets, Chicago, U.S.A.

MODELS & EXPERIMENTAL WORK Anything from a Watch to an Automobile CHAS. E. DRESSLER & CO., 141-143 East 23d Street, New York City

New York Model and Experimental Works INVENTIONS DEVELOPED. SPECIAL MACHINERY 442 East 166th Street New York, N. Y.

INVENTORS, MANUFACTURERS, METAL SPECIALTIES. FIGURE TALKING MACHINES, PRESSES, WAGONS, ETC.

SEALED PROPOSALS.

SEALED PROPOSALS will be received at the office of the Director of the Census, Washington, D. C., until 2 o'clock, July 19, 1909, and then publicly opened for furnishing all the labor, materials and work necessary for the construction in lots of 100, 150, 250, or 500 Automatic Card Punching Machines and delivering the same complete, free of all charges for transportation, at the Census Building, Washington, D. C. The right is reserved to accept or reject any or all bids in whole or part, to strike out any item or items in the specifications, and to waive any defects. For further information, specifications, blue print drawings, blank proposals, and full information address E. Dana Durand, Director of the Census, Department of Commerce and Labor, Washington, D. C.

DIE MODELS SPECIAL WORK TOOLS MACHINERY NATIONAL STAMPING AND ELECTRIC WORKS 153-159 S. Jefferson Street, Chicago, Ill.

NOVELTIES & PATENTED ARTICLES MANUFACTURED BY CONTRACT. PUNCHING DIES, SPECIAL MACHINERY. E. KONIGSLOW STAMPING & TOOL WORKS, CLEVELAND, O.

BASKETS. Calendar and Paper Cutter Free Crane Bros. Mfrs., Westfield, Mass

The Ball Transmission FOR Automobiles & Motor Boats NEW YORK GEAR WORKS. SEND FOR CATALOGUE 20 GREENWICH AVE. BROOKLYN, N. Y.

COLD GALVANIZING.
AMERICAN PROCESS. NO ROYALTIES.
 SAMPLES AND INFORMATION ON APPLICATION.

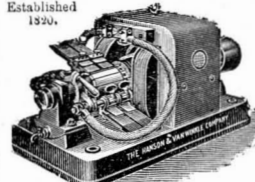

Established 1870.

NICKEL
 AND
Electro-Plating
 Apparatus and Material
 THE
Hanson & VanWinkle
 Co.,
 Newark, N. J.
 28 & 30 S. Canal St.
 Chicago.

A Clean Shave

Your Automatic Stropper for Gillette blades was received in good order and am so pleased with it that I would not take ten times the price for it now.

R. G. McKibbin,
 Knowlton, Quebec, Can.



The motion is automatic, no practice required, a child can use it. Sent postpaid on receipt of price. Be sure to state for what make of Blade. Money willingly refunded if not entirely satisfactory. Write for descriptive circular. Agents wanted.

In case with barbers' genuine Horse Hide Strop, \$2.00

GAYLOR AUTOMATIC STROPPER CO.
 Stamford, Conn.

BENJAMIN AIR RIFLE

The Gun That Shoots.
 FOR MEN AND BOYS



Sends a shot entirely through one-half inch pine and more. Uses compressed air - no spring same as used by powerful rock drills, air brakes, etc. Many times more powerful than any other Air Rifle. Force of shot under control. Accurate. One user shot 50 sparrows in one day.

Shot Arched by this gun at iron target at 50 feet. Another shoots pennies tossed into the air. Others shoot rabbits and squirrels. Practical gun for all small game. Discharge does not scare game. Can be used where cartridge guns cannot, indoors or out. Ammunition cost 10c or 15c for 1,000 shots. Sold by dealers and jobbers. If your dealer does not sell it, write us. There is no substitute or "just as good." Sent prepaid in U. S. and parcels post countries upon receipt of \$2.50. Descriptive circulars upon request. Benjamin Air Rifle & Mfg. Co., 504 Leader Bldg., St. Louis, Mo.

The Oil for Every Car

The cost of maintaining your automobile and the amount of service it gives you depend to a great extent on the use of the proper oil. No matter what the make of your car, its type or purpose, the right grade of Vacuum MOBILLOIL will give it perfect lubrication at all times and under all conditions.

VACUUM MOBILLOIL

is made in six different grades. One of these grades is prepared especially for the perfect lubrication of your car. By the use of this one grade you will save time and trouble and avoid expensive experiment.

Send for booklet listing every automobile made and the grade of MOBILLOIL prepared for it. Thereafter you need only watch the label on the can; the car will take care of itself. The booklet is free; its facts on the science of lubrication are invaluable. Give track records to date, and other potent motor pointers.

MOBILLOIL, in barrels and in cans with patent pouring spout, is sold by dealers everywhere. Manufactured by

VACUUM OIL CO.,
 Rochester, N. Y.

CONCRETE HOUSES
 Cost Less Than Wood

More handsome than Brick. Durable as granite. A Pettyjohn \$35.00 concrete block machine, sand, gravel and cement are all that is needed. Simple, easy and quick. We furnish full instructions. Save money for yourself or make money by selling blocks.

Write for catalog and suggestions

THE PETTYJOHN CO., 615 N. Sixth Street, Terre Haute, Ind.

HALF DOLLAR TAP WRENCH

worth twice its price is our No. 174, as shown in cut. It is made of steel, neatly finished, and will hold any tool that can be put into it - taps, reamers, drills, etc. Holds tools of any shape, round, square or oval. 3 inches long. Price 50c.

Send for 232 page catalog No. 18-B.

THE L. S. STARRETT CO., Athol, Mass., U. S. A.

LUFKIN
TAPES AND RULES
 ARE THE BEST.

For sale everywhere. Send for Catalog No. 16.

LUFKIN RULE CO.
 Saginaw, Mich., U. S. A.
 New York and London.

HELMETOIL
 LUBRICATES SEND FOR SAMPLE FREE
 ANYTHING 15-21 S. CLINTON ST.
 C. H. BESLY & CO. CHICAGO, U.S.A.

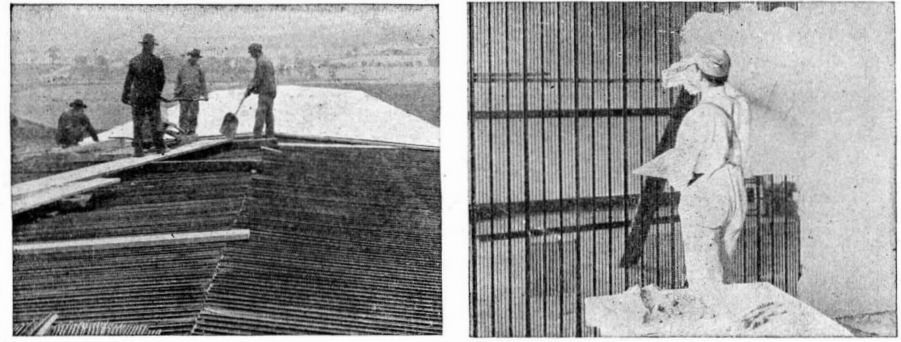

Hy-Rib Roofs and Sidings

Hy-Rib is a steel lath with deep stiffening ribs - serves as reinforcement for concrete floor and roof slabs, doing away with all centering. In walls and partitions no studs are necessary.

Simply set the Hy-Rib sheets in place - apply the cement mortar - the wall and roof are complete. Local builders or your own men can erect it. No chance for mistakes.

Hy-Rib plastered with cement means fireproof concrete construction at lowest cost. Ideal for Sidings, Walls, Partitions, Floors, Roofs, and Ceilings. Eliminates fire risks - Does away with the expense of repairs and maintenance. Use Hy-Rib in place of inflammable wood sheathing and short-lived, leaky corrugated iron.

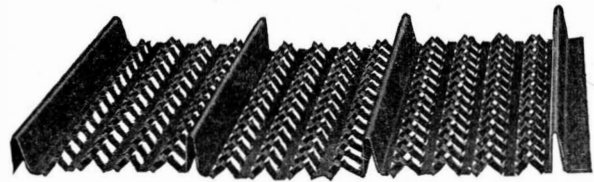

Write for free Hy-Rib Catalogue. Hy-Rib is one of the products of
Kahn System Reinforced Concrete

Other Kahn System Products include Kahn Trussed Bars, Rib-Metal, Rib-Lath, Cup-Bars, and TRUS-CON Chemical Products for finishing and waterproofing concrete.

The Kahn System of Reinforced Concrete has been used in over 2500 structures in all parts of the world, Factories, Warehouses, Stores, Office Buildings, Residences, Bridges, etc.

One large Engineering Department has been organized to co-operate with you or your architect or contractor. No matter what type of building you are interested in - large or small - it will pay you to write us. Send us outline of your proposed buildings.

TRUSSED CONCRETE STEEL COMPANY
 OFFICES IN PRINCIPAL CITIES 515 Trussed Concrete Bldg., DETROIT, MICH.

KAHN SYSTEM

WANTED - A RIDER AGENT in each town and district to ride and exhibit a 1909 Model "Ranger" bicycle furnished by us. Our agents everywhere are making money fast. Write for full particulars and special offer at once.

NO MONEY REQUIRED until you receive and approve of your bicycle. We ship to anyone, anywhere in the U. S. without a cent deposit in advance, *prepay freight*, and allow **TEN DAYS' FREE TRIAL** during which time you may ride the bicycle and put it to any test you wish. If you are then not perfectly satisfied or do not wish to keep the bicycle you may ship it back to us at our expense and you will not be out one cent.

FACTORY PRICES We furnish the highest grade bicycles it is possible to make at one small profit above actual factory cost. You save \$10 to \$25 middlemen's profits by buying direct of us and have the manufacturer's guarantee behind your bicycle. **DO NOT BUY** a bicycle or a pair of tires from anyone at any price until you receive our catalogues and learn our unheard of factory prices and remarkable special offers to rider agents.

YOU WILL BE ASTONISHED when you receive our beautiful catalogue and study our superb models at the *wonderfully low prices* we are satisfied with \$1.00 profit above factory cost. **BICYCLE DEALERS**, you can sell our bicycles under your own name plate at double our prices. Orders filled the day received.

SECOND HAND BICYCLES. We do not regularly handle second hand bicycles, but usually have a number on hand taken in trade by our Chicago retail stores. These we clear out promptly at prices ranging from \$3 to \$5 or \$10. Descriptive bargain lists mailed free.

TIRES, COASTER-BRAKES, parts, repairs and equipment of all kinds at half the usual retail prices. **DO NOT WAIT**, but write today and we will send you free by return mail our large catalogue, beautifully illustrated and containing a great fund of interesting matter and useful information; also a *wonderful proposition* on the first sample bicycle going to your town. It only costs a postal to get everything. **Write it now.**

MEAD CYCLE COMPANY Dept. L 175 CHICAGO, ILL.

Something New **A Reliable, Accurate and Hard Hitting Air Gun** **At a Moderate Price**

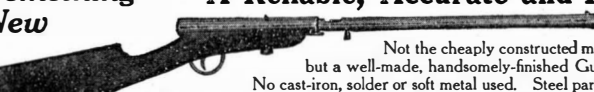

Not the cheaply constructed make-shift that lasts for a few days or weeks, but a well-made, handsomely-finished Gun that may be used indefinitely.

No cast-iron, solder or soft metal used. Steel parts finished in dark blue, and walnut stock in oil and varnish. Rear adjustable sight. Loads from Breech and Shoots Either Darts, Slugs or Shot. May be entirely taken apart in a moment for cleaning or inspection. So accurate and reliable that adults enjoy shooting with it. Write today for full particulars. If your dealer cannot supply you, will ship direct on receipt of \$3.60, charges prepaid. Colored paper Targets, Darts and a Ramrod accompany each Gun. Address

H. M. QUACKENBUSH (Maker of High Grade Air Guns for 35 Years)
 Dept. 22, HERKIMER, N. Y.

PERFECTION MARINE ENGINES Catalog Free



For launches up to 26 ft., horse-boats or auxiliary for sailboats, buy the famous 6 H. P. "Perfection." Stroke 4 1/2 in., bore 4 1/2 in. Compare with engines of similar rating; convince yourself that you want the "Perfection." Easy starting, simple, reliable. Will stand all kinds of hard work and rough usage. Schuber Carbureter; jump spark ignition; counter-balanced crankshaft; solid propeller. Complete, ready to install, \$95. 2 H. P. complete, \$35. Any size up to 25 H. P. at equally low prices. Write for catalog and full information about our "Square Deal" plan. The Gaille Perfection Motor Co., 1343 2d Ave., Detroit, Mich.

Engineering News
 (ILLUSTRATED)

The Leading Engineering Paper of the World. For Civil, Mechanical, Mining and Electrical Engineers 100 to 125 pages, 9" x 13", weekly. Send ten cents for sample copy.

If you cannot locate desired engineering equipment write our "Readers Want" department.

THE ENGINEERING NEWS PUBLISHING CO. 214 Broadway, New York

Railroad Securities and High Grade Industrial Bonds
 of proven value for conservative investment, dealt in by
McCurdy, Henderson & Co., Bankers
 Members New York Stock Exchange 24 Nassau Street, New York

UP TO DATE AND SAFE!



Remington
SOLID-BREECH HAMMERLESS

The Remington is the oldest Arms Company in America, yet Remingtons represent the youngest, the most modern ideas of all. The Remington Autoloading Shotgun and Rifle load themselves by recoil. Like the Remington Pump Gun they are Solid Breech Hammerless - are in a class by themselves.

SAFETY is the keynote of a Remington. The thick wall of solid steel protects your face.

Get a modern, up-to-date Remington - the gun that represents safety and 20th Century Progress.

Booklet N tells of Buffalo Jones roping wild cats.

THE REMINGTON ARMS CO.
 Ilion, N. Y.
 Agency, 315 Broadway, New York City

McIntyre Guaranteed Sure-Service Always-Ready



Model H 12-H.P. \$475

motor buggies and wagons have proved their positive worth as pleasure vehicles and money-saving work vehicles for thousands in every part of the civilized world.

Why Not For You?

McIntyre
 Motor Vehicles

never fail - never get tired - cost no more than a good horse and buggy - cost far less to keep - do more work in less time than three horses. Take you anywhere and back again over any kind of road, in all kinds of weather. Run 30 miles on one gallon of gasoline. Simple, durable, guaranteed mechanical construction. Solid tires - no tire troubles or repairs expense. For Free Catalog No. 68 address nearest office. **W. H. McIntyre Co., Auburn, Indiana** 256 Broadway, New York; 1730 Grand Ave., Kansas City; 418 Third Ave. So., Minneapolis; Tudhope McIntyre Co., Orelia, Can.

Automobile Trouble AND A CURE
Dunn's Allright Spark Plug
 Standard and Metric Thread, \$1.50
 GUARANTEED FOREVER
DUNN MACHINERY CO., Atlanta, Ga.

THE "BEST" LIGHT!



EVERY one is a self-contained miniature light works. 100 to 2000 candle power. Costs less than kerosene.

Absolutely safe Very brilliant Powerful and Steady.

Every lamp warranted. Over 200 styles. Agents wanted. Catalog free. Write to-day.

The Best Light Co.
 87 E. 5th St. Canton, O.

MAKES AND BURNS ITS OWN GAS

WE WILL MAKE your models and give you estimates on manufacture of any metal novelty. Automatic machinery, tools, dies and expert work our specialty. **AUTOMATIC HOOK & EYE CO.,** Hoboken, N. J.