

SCIENTIFIC AMERICAN

[Entered at the Post Office of New York, N. Y., as Second Class Matter. Copyright, 1909, by Munn & Co.]

Vol. C.—No. 17.
ESTABLISHED 1845.]

NEW YORK, APRIL 24, 1909.

[10 CENTS A COPY
\$3.00 A YEAR.]

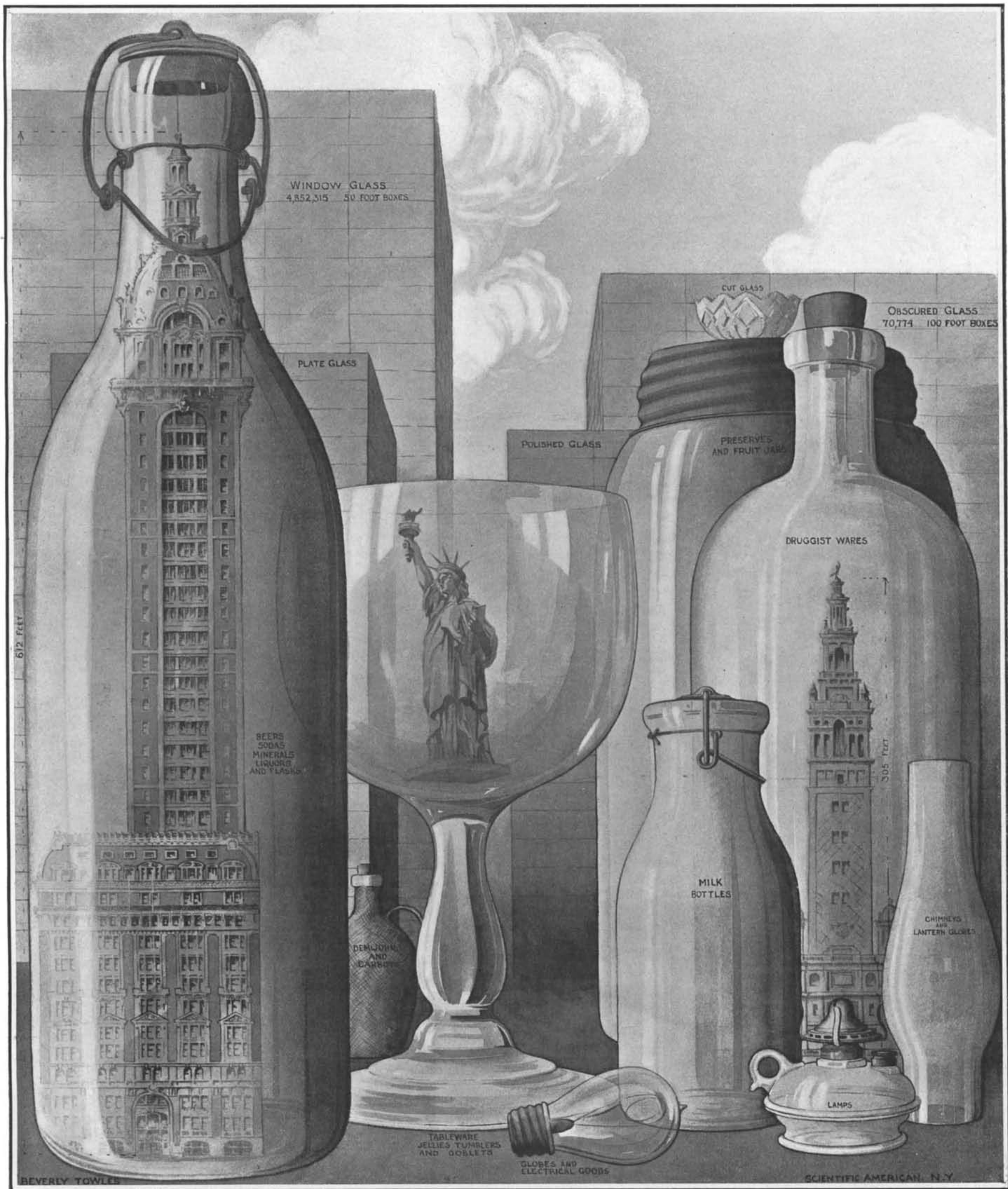

Copyright 1909 by Munn & Co. All rights reserved.

THE GIANT GLASS INDUSTRY. NEARLY \$80,000,000 WORTH OF FUSED SILICA MADE ANNUALLY IN THE UNITED STATES.—[See page 314.]

SCIENTIFIC AMERICAN

ESTABLISHED 1845

MUNN & CO.

Editors and Proprietors

Published Weekly at

No. 361 Broadway, New York

CHARLES ALLEN MUNN, *President*
361 Broadway, New York.FREDERICK CONVERSE BEACH, *Sec'y and Treas.*
361 Broadway, New York.

TERMS TO SUBSCRIBERS.

One copy, one year, for the United States or Mexico \$3.00
 One copy, one year, for Canada 3.75
 One copy, one year, to any foreign country, postage prepaid, 18s. 6d. 4.50

THE SCIENTIFIC AMERICAN PUBLICATIONS.

Scientific American (established 1845) \$3.00 a year
 Scientific American Supplement (established 1876) 5.00 "
 American Homes and Gardens 3.00 "
 Scientific American Export Edition (established 1878) 3.00 "

The combined subscription rates and rates to foreign countries, including Canada, will be furnished upon application.
 Remit by postal or express money order, or by bank draft or check.

MUNN & CO., 361 Broadway, New York.

NEW YORK, SATURDAY APRIL 24th, 1909.

The Editor is always glad to receive for examination illustrated articles on subjects of timely interest. If the photographs are *sharp*, the articles *short*, and the facts *authentic*, the contributions will receive special attention. Accepted articles will be paid for at regular space rates.

THE "DREADNOUGHT" COMPETITION.

The game of war begins to assume Brobdnagian proportions when it is played with battleships costing \$10,000,000 apiece for counters. England and Germany appear to be playing such a game just now; and this in spite of the fact that the latest official pronouncements of the two governments would lead us to suppose that the dove of peace hovers undisturbed above the international checkerboard. The present feverish excitement over the progress of Germany in the construction of battleships, is due to the sudden realization by the people of Great Britain that the excellent German system of building according to a definite programme, extending over a period of years, gives an assurance of a definite future strength and standing, which is wanting under the British system of leaving each year's addition to the navy to be decided by the caprice of the particular political party, which happens for the time being to hold the reins of office. Furthermore, by a dexterous manipulation of statistics, the party in Great Britain which is desirous of building the biggest possible navy that the liberality of Parliament will allow, has endeavored to impress the public with the belief that within two or three years' time Germany will be in possession of a greater number of "Dreadnoughts" than Great Britain itself. The note of alarm has served its purpose so well (or so ill, according as we look at it) that the Parliament has passed a bill authorizing the construction of eight of these huge and costly vessels, the appropriations for which alone will reach the huge sum of not less than \$80,000,000. That the alarm over conditions, fictitious though we believe them to be, has spread throughout the whole of the British empire, is shown by the offer of three of the leading colonies to contribute, should the mother country desire it, six additional "Dreadnoughts," or their equivalent in naval construction. This, expressed in terms of dollars and cents, would mean an additional \$60,000,000; which brings the total sum that the British empire stands prepared to invest in new battleships alone up to a round sum of about \$140,000,000.

But although we regard the immediate cause of this excitement as fictitious—the progress of German shipbuilding for the past year having been neither faster nor slower than its predetermined and publicly-announced plan called for—the spirit which has been revealed during the discussion shows how deeply is engrafted in the national consciousness of the British people the conviction that the security of the island itself, the integrity of the empire, and the preservation of its commercial supremacy, depend upon the maintenance of an overwhelming preponderance of sea power. This is a principle which has become practically the first article of faith in the catechism of British international politics. Its soundness, at least as affecting British interests, has never been called in question by the other leading powers of the world.

ECONOMIC LOSS THROUGH THE MOSQUITO.

It is well understood that the mosquito, as a vehicle for the spread of disease, is responsible for an untold amount of sickness and general inconvenience. Not all of us, however, appreciate the heavy incidental losses due to the depreciation in the value of mosquito-infected districts, the impairment of the vitality, and, therefore, of the earning capacity, of malarial patients, and the large total resulting losses as expressed in dollars and cents. A valuable study of this subject has been made by Dr. L. O. Howard, Chief of the Bureau of Entomology of the Department of Agriculture, and presented in a recently-issued Bulletin upon the subject of the economic loss to the people of the United States through insects that carry disease. The subject is dealt with mainly under the three heads

of Malaria, Yellow Fever, and the Typhoid Fly. In the present notice we confine ourselves to the mosquito as a vehicle for the spread of malaria.

It is contended that malaria has retarded in a marked degree the advance of civilization over the North American continent. Particularly was this seen in the march of the pioneers through the middle West and the Gulf States west of the Mississippi. In attempting to estimate the economic loss from the prevalence of malaria, reference is made to the method of Prof. Fisher, given before the recent International Tuberculosis Congress, by which he arrived at an estimate of over a billion dollars annually as representing the cost of tuberculosis to the people of the United States. In this estimate Prof. Fisher considered the death rate for consumption, the loss of the earning capacity of the patients, the period of invalidism, and the amount of money expended in the care of the sick. No such definite basis is available for estimating the effects of malaria; but Dr. Howard, by using the statistics of deaths due to malaria in sixteen of the northern States during the period from 1900 to 1907, arrives at an approximate death rate for the whole of the United States of 12,000 per year. In the case of malaria, however, the death rate is a less sure indication of the real economic loss than in the case of any other disease; for a man may suffer from malaria for the greater part of his life, with a reduction of his productive capacity of from fifty to seventy-five per cent, and yet ultimately die from some entirely different immediate cause. Sir Patrick Manson, writing of tropical countries, declares that malaria causes more deaths, and more predisposition to death, than all the other parasitically-induced diseases affecting mankind, together. Celli states that, owing to malaria, about five million acres of land in Italy remain very imperfectly cultivated. Creighton says that this disease has been estimated to produce one-half of the entire mortality of the human race; and, inasmuch as it is the most frequent cause of sickness and death in those parts of the globe that are most densely populated, he considers that the estimate may be taken as at least rhetorically correct.

Now, although there is no perfectly sound basis for a close estimate, at least in this country, between the number of cases of malaria and the number of deaths resulting therefrom, an estimate based by analogy upon Celli's investigation of malarial mortality in Italy leads Dr. Howard to the conclusion that the approximate number of cases of malaria in the United States must be about 3,000,000. We quite agree with the doctor that it is no exaggeration to estimate that one-fourth of the productive capacity of an individual suffering with an average case of malaria is lost. With this as a basis, and including the loss through death, the cost of medicine, the losses in malarious regions through the difficulty of obtaining competent labor, it is estimated that the loss to the United States, from malarial diseases, under present conditions, is not less than \$100,000,000 every year.

THE HUDSON-FULTON CELEBRATION.

The celebration of two such epoch-making events as the discovery of the Hudson River and the inauguration of steam navigation upon its waters is an undertaking, whose execution upon a scale commensurate with the importance of the occasion, calls for no small expenditure of thought, labor, and money. We have before us a brief statement of the object and plan of the Hudson-Fulton celebration, which shows that, as far as a well-thought-out plan can assure success, the committee has done its work thoroughly. An ambitious affair of this kind, however, must not be carried through with an over-careful consideration of the cost. If it is to be consummated with the *éclat* which its importance demands, there must be none of that lack of funds which may so easily transform an ambitious pageant, or series of pageants, of this kind into a pitiful farce. The State is committed to the enterprise; it has received world-wide advertisement, and it is for the Legislature, the various State societies, and the individual citizens of the State to join hands in rendering the forthcoming celebration worthy of the great events that it will commemorate.

It is the boast of New York State that it contains in New York harbor the principal gate of entrance, and in the Hudson River the geographical key, to the United States and the vast regions lying to the west of the Allegheny Mountains. This noble river and the magnificent harbor into which it discharges have exerted an influence in the development of the latest and greatest of the important republics of the world, which it would be hard to overestimate. When Henry Hudson sailed his little craft nearly 150 miles through navigable water into the very heart of the country, he doubtless understood, navigator and trader that he was, how valuable a route was here for the seaborne traffic of the future; but he little realized that the river formed merely part of what, in the days of the Indian occupation, was already a

great highway of travel by river, portage, and vast inland lakes, to the remote regions of western America. Still less did he understand that from the farthest point to which he had penetrated would be built in later days a great artificial waterway, through which vessels, many times larger than the "Half Moon," would be able to navigate uninterruptedly from the river's mouth to a system of vast inland seas, from whose shores they would gather and bring down to the seaboard the products of a country rivaling in area and resources that continent from which he had set sail on his adventurous quest.

We can do no more just here than give a brief summary of the elaborate plans of the celebration.

The services will begin on Monday, September 27th, 1909, with a rendezvous of American and foreign naval vessels at New York, when a *facsimile* of Hudson's "Half Moon," now being built in the Netherlands from the original plans, will enter the river and take her place in line. A *facsimile* of Fulton's "Claremont," propelled by its own engines, will start from the original site, and will also take position in line. On the same day will be opened an exhibition of paintings, books, relics, etc., at the Metropolitan Museum of Art, the American Museum of Natural History, and all the various historical societies. On Tuesday there will be a procession of historical floats, and possibly on this day will take place the competition of mechanically-propelled airships for a prize of \$10,000 offered for the winner of a race from New York to Albany. General Commemoration Day is set for Wednesday, September 29th, when there will be a dedication of memorials erected in the Hudson River valley. The number and location of some of these are unsettled, but the commission is satisfied that monuments to William the Silent and Henry Hudson, a tablet to the Founders and Patriots of New York, and a tablet on Fort Tryon, will be ready for dedication. Statues of Robert Fulton at Peekskill, Governor Clinton at Kingston, Peter Schuyler at Albany, and Van Rensselaer at Troy have been suggested. The present is an excellent opportunity for the citizens of those towns and the counties in which these towns are located to erect appropriate and too-long-delayed tributes to these distinguished men. On the same day there will be exercises at the universities and colleges throughout the State. Thursday will be devoted to military displays by the army, navy, and national guard. On Friday there will be a naval parade to Newburg, in which the "Half Moon" and the "Claremont" will be the center of attraction. After the parade has reached Newburg, a memorial arch, erected by the Daughters of the Revolution, will be dedicated.

The first week of festivities will close on Saturday, October 2nd, which is designed for a general carnival day in New York city. It will be marked by the return of the New York division of the naval parade to its starting point; and it will terminate in the evening with a grand carnival parade, the chief feature of which will be movable allegorical tableaux to be participated in by all nationalities represented in New York city. There will be a general illumination of the city, a special feature of which will be the display of fireworks from the great bridges of the East River. At 9 P. M. a chain of signal fires upon the mountain tops and other points of vantage along the whole Hudson River will be lighted simultaneously.

What will be known as Upper Hudson Week will begin on Sunday, October 3rd, when the "Half Moon" and "Claremont" will continue their journey up the river, escorted by a fleet of vessels. The center of interest on Monday will be found at Poughkeepsie, which will witness a naval parade and the erection of a statue of Robert Fulton. On Tuesday the parade will proceed to Kingston, where it is proposed to erect a permanent memorial in the form of a statue of Governor Clinton. Wednesday will find the parade at Catskill. Thursday it will reach Hudson, where a statue of the great explorer is proposed. Friday the flotilla will reach the capital of the Commonwealth, where it is hoped a statue of Peter Schuyler, the first Mayor of Albany, will be ready for dedication. Saturday, the close of the fortnight of festivities, will be marked by the arrival of the naval parade at Troy, where it is proposed to erect a statue of Van Rensselaer, who obtained the first land grant in that section of the country.

WILBUR WRIGHT'S FLIGHTS IN ITALY.

Last week Wilbur Wright made his first aeroplane flights in the vicinity of Rome. The flights were made above the plain of Centocelle, and were witnessed by a great and enthusiastic crowd. The champion aviator took up several army and navy officers. On April 16th he made three flights of 6, 10, and 5 minutes' duration. On the longest of these he flew very close to a villa, and afterward rose to a height of 150 feet. The onlookers were astonished at his performance, and at the perfect control he had over his machine. King Humbert expects to witness some of the flights.

ENGINEERING.

Some great records for steam shovel work are being made on the Panama Canal. Recently, during a working day of eight hours a steam shovel, operating in the Empire Construction District, removed 3,941 cubic yards of rock and earth. The shovel was actually at work only six hours and fifty minutes of this time, one hour and ten minutes being consumed in waiting for the cars.

The extension of the railroad system of China is proceeding steadily, if rather slowly. At the present time the total amount of road in active operation is 2,170 miles. There are 806 miles of new road under construction; provision has been made for the construction of an additional 2,232 miles; and 3,286 miles of new line are projected.

A recent report of the power efficiency committee of the American Railway Association shows that during the first fortnight in March there was a decrease in the number of surplus cars of 8,507, the total number of idle cars on March 3rd being 299,925, and on March 17th, 291,418. This steady placing of cars in service is one of the sure indications of the slowly returning prosperity of the country.

Advices from England state that the new protected cruiser "Boadicea" during her full power trials exceeded the record for a vessel of her size. The maximum speed achieved is said to have been 27.9 knots. She was designed for a speed of 25 knots, which was also the designed speed of the cruiser battleships of the "Indomitable" class, whose speed records of 26 knots and over now appear to have been surpassed by the "Boadicea."

According to an eminent German economist the aim of a healthy transportation policy should be to diminish, as far as possible, the economically unproductive cost of transport. It is in agreement with this policy that Germany has built up and is continually extending her inland waterways, upon which, during the past twenty years, she has expended \$150,000,000. At the present time Germany possesses in navigable rivers, canalized rivers, and inland canals over 8,278 miles of navigable waterways.

Speaking of canals, we note that the creation of an important naval base on the Firth of Forth on the east coast of Scotland has brought the question of a ship canal between the Forth and the Clyde once more prominently into public notice. As a commercial undertaking such a canal would have comparatively limited value; but for strategical reasons, as affording means of quickly concentrating the warships of the North Sea and the Irish Channel, on either coast, the canal would be worth the heavy expenditure which its construction would involve.

In an effort to provide shippers of coke with an improved car which can be loaded and unloaded in the shortest possible time, the Pennsylvania lines west of Pittsburg have specified that of the recent order for 3,200 new cars, 1,000 should be all-steel cars of new design and of greater capacity than any coke cars hitherto built for regular service. The chief novelty will consist of four hoppers with eight openings in the bottom of the car, making the latter practically self-clearing. The total capacity of each car is 100,000 pounds.

In spite of the rapid increase in the number of automobiles and trolley cars, the horse continues to more than hold his own. According to figures published in the last report of the Department of Agriculture, the number of horses in the United States increased from 13,537,000 in 1900 to 19,992,000 in 1908, the total value of the same having risen from \$603,000,000 to \$1,867,000,000. The fluctuations in the average price of horses have been remarkable. In 1893 it was \$61; in 1897, \$37; \$44 in 1900, and \$93 in 1908.

The conviction seems to be widespread that the future will witness a great increase in the dimensions of warships. That the German government is of this opinion is shown by the enlargement of the Kaiser Wilhelm Canal, which is to be deepened at once to 36 feet, with provision for a later deepening, if necessary, to 46 feet. The width of the canal is to be doubled, and the new locks at each end of the canal are to be 1,082 feet long, 147 feet broad, and 46 feet deep. These dimensions, by the way, considerably exceed those of the canal locks at Panama.

The huge dredger built for keeping open the Mersey Channel is aptly named the "Leviathan." She is 465 feet 9 inches in length, and is capable of pumping up 10,000 tons of sand and discharging it into her bunkers from a maximum depth of 70 feet in 50 minutes time. The pumping plant consists of four independent centrifugal pumping engines, each of 800 horse-power. Her capacity is shown by the fact that in a five hours' test, 20,000 tons of material was lifted from the Channel into the hoppers, carried 10 miles, and dumped. In a favorable year of work the "Leviathan" will dredge and remove to a suitable dumping ground at least 20,000,000 tons of sand.

ELECTRICITY

A report of the telegraph and telephone situation in Germany in 1906 to 1907 has just been published. The total length of the telegraph and telephone lines is over 2,800,000 miles, 1,360,000 miles of which are underground. There is a telephone exchange for every 1,956 inhabitants.

Some successful experiments with wireless telephony have recently been made by Lieuts. Colin and Jeance, between Paris and Melun, a distance of thirty miles. The Paris station was located at the Eiffel Tower and was operated by Lieut. Colin, while Lieut. Jeance, with the Minister of Marine, operated the instruments at Melun.

An electric railway between South Bend, Ind., and Pullman, Ill., has just been completed. The line is 77½ miles long and the single-phase system is used. The motor cars are each equipped with four 125-horsepower motors. The main line is furnished with current at 6,600 volts pressure, but this is reduced to 700 volts in cities. Pantograph collectors are used for collecting current at the higher tension.

Plans are under way for providing an unusually attractive electrical illumination during the Hudson-Fulton celebration next fall. It has been proposed to light up Washington, Union, and Madison squares and Riverside Park by means of lamps placed in the foliage. Mercury vapor lamps could be used to advantage so as to produce a remarkable effect. The Hudson River will be illuminated with search lights, while prominent buildings on Broadway and Fifth Avenue will be outlined with small electric lamps. The city has appropriated \$300,000 for this celebration.

A device is being placed on the market for preventing a consumer from using more current on his lighting circuit than he has contracted for. When the current consumption reaches the contract limit the lights begin to flicker and continue to do so until normal current is restored. This result is produced by means of a magnet which attracts a spring metal armature. By adjusting the tension of the spring the device may be set to operate at various loads. The mechanism is made to operate on two and three-wire circuits.

According to a daily press report a safe lock has been invented which is provided with phonographic mechanism so that it can be opened only by the voice of the owner. A mouthpiece like that of a telephone takes the place of a knob on the door, and this is provided with the usual style or needle which travels in a groove in the sound record of the phonograph cylinder. Before the safe can be unlocked the password must be spoken into the cylinder by the one who made the original record. The report does not state what would occur if the owner should come down to his office with a bad cold.

In order to do away with the bother of attending to exhausted batteries of doorbell systems, a transformer has just been put on the market which enables one to obtain the current from the city mains. The transformer will operate on the ordinary lighting circuits, and can be installed by anyone with a slight knowledge of electricity. As it has no moving parts, once installed it will thereafter require no attention. It is adapted to operate on circuits running from 100 to 130 volts, and is provided with taps giving 6, 12, and 18 volts, so as to meet the requirements of various styles and sizes of bells and buzzers.

In many of the smaller European towns oil engines are coming into favor as prime movers in central power stations. The reason for preferring oil engines to other engines is that they require very little space and are always ready for work. An excellent example of this use of the oil engine is to be found in the town of Iglau, Austria. The plant is described in a recent number of the Electrical World. This plant is provided with two 200-horse-power engines, rated at 165 kilowatts, and a two-cylinder engine of 130 horse-power operating a 106-kilowatt generator. Tests have shown that 272 grammes of oil are consumed for each kilowatt hour on a full load.

A new type of army rifle is being manufactured at the Springfield armory which differs from the ordinary in having electrically lighted sights for use at night. A battery is fitted in the stock of the rifle and serves to light a pair of miniature electric bulbs, placed at each side of the gun barrel, at the extreme end. The button which controls the electric circuit is fitted on the trigger guard, and when the operator presses this button the miniature lamps serve to light the rifle sight. The lights themselves are shielded from view. In twilight hours it is often impossible to take any aim with the ordinary rifle, although the object fired at, owing to its size, may be readily seen. By illuminating the sight in the manner just indicated, the shooter may aim quite accurately. The invention should be valuable for close-range fighting at night.

SCIENCE.

From extended experiments that have recently been made at Macon, Ga., it has been found that a fine grade of paper can be made from pulp prepared from the okra stem, and a plant for making paper from this source is likely to be erected in that city at an early date. Okra is easily grown in the Southern States, and could be produced in large quantities as a paper-making plant. The plant is an herb belonging to the mallow family, genus *Hibiscus*. Its botanical name is *Hibiscus esculentus*.

The first operation in this country upon a human being in which the cavity of the thorax was opened while the lungs were inflated from a chamber containing air at a greater pressure than that of the atmosphere was performed recently at the German Hospital by Dr. Willy Meyer. Many operations in the thorax have been difficult to perform, and others impossible because as soon as the cavity of the thorax is opened the lungs collapse because of the atmospheric pressure.

Later information on the results of Lieut. Shackleton's expedition to the Antarctic revealed much that was not discussed in the preliminary dispatches. It is now brought out plainly that the south magnetic pole like the north magnetic pole shifts its position. The discovery is important, because it will enable us to revise our magnetic charts and render navigation safer. It was not known before Shackleton's expedition whether or not the south geographical pole is a vast archipelago or a continent. Shackleton seems to have established the second view on a fairly firm basis.

Commandant Souié, of the Paris police, has perfected, for the use of the men in his command, spectacles, with the aid of which they may not only see very plainly what is going on ahead of them, but at the same time command a view of what is going on behind them, an arrangement that is expected to contribute materially to their efficiency. At the outer edge or corners of these unique "specs," small, concave mirrors are attached. They are very "true" and so placed as not to interfere in the least with the forward view of the wearer of the spectacles. After brief preliminary use they are found to give excellent service.

It will be remembered that M. Yves Delage succeeded in obtaining two good specimens of sea urchin by parthenogenesis at the Biological Station of Roscoff, France. These specimens continued to grow very well, but not long since they died from some cause which is unknown. M. Delage points out that the death was not due to any imperfections in the specimens. Both the specimens resulted from experiments with hydrochloric acid and ammonia. Both of them had a regular growth up to the time of their death, that is, about sixteen months after the metamorphosis. Death was probably due to poisoning in some way.

Owing to the careful adjustment and regulation of temperature necessary in bacteriological incubators, a new incubator has recently been built which will thus overcome the difficulties with gas-heated incubators. Incandescent lamps are used in the new heater to maintain the required temperature of 37 2/5 deg. C. A new mercury regulator controls the lamps. The instrument was tested quite recently for a run of forty-five days and the variations in temperature during this time were practically nothing. The incubator is formed with a triple wall, providing a water jacket and an air space, and is covered with asbestos finished in white enamel.

In a recent investigation of the influence of sulphur in illuminating gas upon the air in rooms, Mr. Arthur D. Little, chemical expert and engineer, Boston, compared the effect of the burning of a sulphur match with that of an ordinary gas jet. Analysis of the match showed that it contained enough sulphur to momentarily raise the sulphur dioxide in the room to an amount greater than would ordinarily be maintained by sulphur coming from burning gas. It was shown that the lighting of such a match would actually liberate as much sulphur into the room as ordinarily would be liberated by a standard gas jet burning for over twenty minutes.

The Arctic and Explorers' Clubs of America will organize an expedition to go north in search of Dr. Frederick Albert Cook, the polar explorer, who has not been heard from in over a year. Dr. Cook has no means of coming back. It is possible that he wintered somewhere with the Eskimos, where he could get plenty of food, but there is an uncertainty about it. According to the prearranged plans Dr. Cook was to return to headquarters at Annotoak, Greenland; down Kennedy Channel, through Smith Sound, and in case no ship arrived he would move to Cape York and thence to Upernavik, expecting to return home not later than September, 1908.

DEMOLITION OF THE FAÇADE OF THE OLD B. & P. RR. TERMINAL, BOSTON.

BY WILLIAM L. HILL.

When fire recently destroyed a considerable portion of the old Boston & Providence Railroad terminal at Park Square, in Boston—long ago abandoned for railway purposes, and of late used for indoor recreation enterprises—it was determined by those owning the property to remove what was left of the structure. Most of it has been, or will be, razed by the ordinary hand methods, but on account of the shape and size of the great arch, such methods would be hazardous to those employed in the task, and it was decided to bring it down with dynamite.

Accordingly on April 6th, in mid-forenoon, workmen placed in each of the twenty holes drilled in the southerly pier of the arch a stick of 75 per cent dynamite, about 20 pounds in all. These sticks were connected with an electric circuit and the wires strung along the ground to a point several hundred yards away.

To reduce the detonation, and save many windows—for Park Square is almost in the heart of the city—timbers 12 feet long were piled about the base of the pier. Around the timbers an iron chain was drawn, and canvas was wrapped about the chain and timbers.

The explosion was not very loud, to the disgust of the great crowds that were kept at a safe distance by details of police. The entire arch settled, almost slowly, it seemed to the spectators, to the ground, so disintegrated that its removal is an easy task.

The arch was 65 feet high, of 70 feet span, and 3 feet thick. The building was erected in 1872.

To the Inventor of Electric Railway Appliances.

A word to the inventor or the would-be inventor of electric railway apparatus may not be amiss. Their number is probably greater than in any other line of work, due partly to the substantial reward that is offered to those who are successful, partly to the fact that the deficiencies of much of the apparatus in use at present are very evident and partly because statistics show that trolley cars are used by a much larger proportion of the population of this country than any other electrical invention. To almost anyone who is familiar with street railway apparatus, there appear numerous ways in which the device and methods in use in electric railway service could either be improved or be substituted by others, with the result that the cost of maintenance would be lessened, the safety of passengers would be increased, or operation would be facilitated in some other way.

These facts cause many who are not familiar with electric railway operation or the requirements of electric railway apparatus to attempt the rôle of inventors. Such people are greatly handicapped by a lack of knowledge of the actual requirements; on the other hand, they have the advantage of looking at the question from the outside and with a free and untrammelled mind which is rarely possessed by those confined to one line of work. Their limited knowledge of operating conditions, however, usually causes them to waste the greater portion of their efforts by attempting to develop something which is impracticable or whose adoption after being perfected would probably introduce more difficulties than its use would avoid. On the other hand, the fact that they are not constantly thinking about one line of work often enables these outsiders to develop a really much needed article.

There is one device which is as alluring and which is seemingly as impossible to reach as the pot of gold at the end of the rainbow and the average inventor should regard it with caution. This is a self-replacing trolley wheel or a trolley wheel that will not jump the wire. The patent records will show that device after device, all supposed to be improvements on the present trolley, have been patented only to lie dor-

mant. While employed in the shop of a large railway system the writer remembers that it was out of the ordinary if more than two or three weeks went by without some new trolley or trolley harp being offered for trial. The master mechanic of the railway system was one of those broad-minded men who are always willing to investigate and give any new piece of apparatus a trial if it shows possibilities of success or if such trial will rid the inventor's mind of delusions. But he regarded several of these trolley devices as too dangerous to overhead construction to be

dollars had to be expended and those responsible for the scheme either did not have the money or did not have enough faith in their idea to risk parting with this amount.

On another occasion after repeated solicitation a man from a small town of about one thousand people, through which an interurban line ran, was given permission to install an automatic track switch on condition that the company would not be inconvenienced or the street torn up. After the delivery of about two wagon loads of various materials, constituting the parts of one switch, and which included some timbers about ten or twelve inches square and a dozen feet long, the management decided to call a halt, and the inventor (?) considered that he had not received fair treatment from the railway company.

Before bothering a railway company the inventor should feel certain that his device is a practical one and that he has gotten it in as advanced a state as possible, until some of its defects are made evident by trial. But he should not assume that he can make repeated trials to the inconvenience of an accommodating railway company in order to perfect the apparatus. Every breakdown causes the master mechanic, the superintendent of track or of overhead or whoever permits the trial, to lose confidence in both the apparatus and the inventor. Breakdown of experimental apparatus due to a single weak point has often caused the con-

demnation of an otherwise good article.

In developing an idea the inventor should keep simplicity uppermost in his mind. Simplicity carries with it the idea of being easily understood and of something not likely to get out of order. It must be remembered, too, that the apparatus will fall into the hands of men who are not as skilled and as careful as watchmakers and should consequently be built in such a manner that it will stand more than a reasonable amount of abuse. Street railway apparatus and appliances are in fact subjected to about as hard a treatment as any machinery devised, and it is the lack of proper design and construction to withstand such treatment that causes many new devices to be thrown out.

But if the path of the inventor of street railway apparatus is a rather thorny one, the reward is proportionately great. The electric railway fraternity is always ready to adopt a piece of apparatus that proves itself of worth and it is willing to pay well for it.

The writer remembers one casting that sold for about \$9 which to all appearance could not have cost more than 50 cents. On much other apparatus the difference between the cost price and the price at which railways are willing to purchase is almost as great.—John Hobbs, in Street Railway Journal.

Formaldehyde in Milk.

Shrewsbury and Knapp describe, in the Analyst, a rapid method of detecting and estimating formaldehyde in milk. Sixteen volumes of a normal solution of nitric acid, or 6 volumes of pure nitric acid are added to 1,000 volumes of concentrated hydrochloric acid. Two volumes of the mixed acids are heated with one volume of the suspected milk to 122 deg. F. for ten minutes over a water bath, with constant agitation, and suddenly cooled to about 60 deg. F. The presence of formaldehyde is instantly revealed by a violet coloration, and the quantity of formaldehyde can be

estimated by comparing the tint with a series of standard tints produced by mixtures containing known proportions of formaldehyde. The test is most sensitive when the proportion is from 2 to 60 parts of formaldehyde to 10 million parts of milk. If the proportion is greater than this the suspected milk should be diluted with a measured quantity of pure milk.

The greater portion of surveys on the Hudson Bay Railway has been completed. On February 1st, 365 out of a total of 465 miles had been finished.

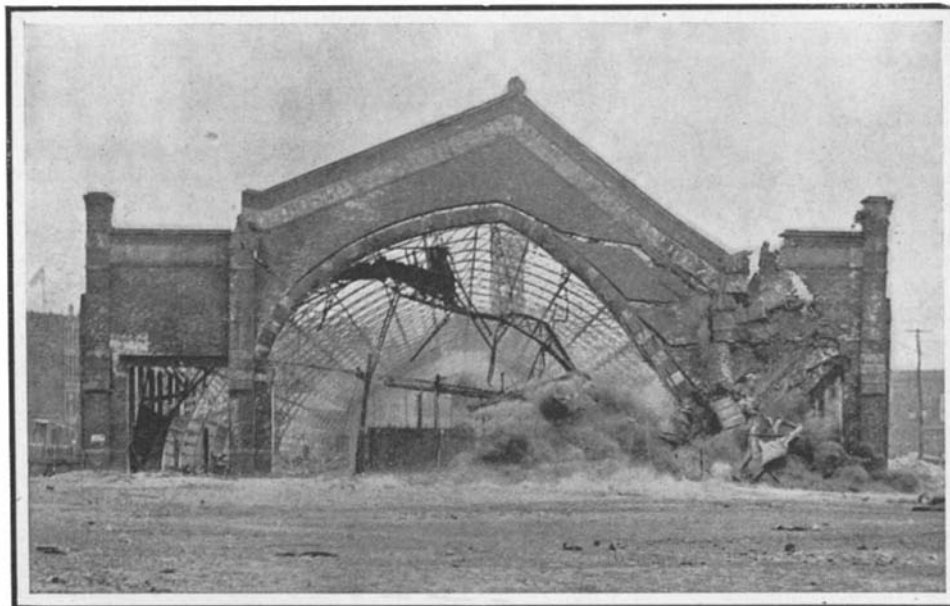

Photograph taken the instant after explosion of twenty pounds of dynamite in right abutment.

permitted on a car, even on trial. Of all the devices submitted not one was suitable and the road, like practically all other direct-current roads in the country, is to-day using the simple trolley wheel and harp.

Those who have devised apparatus which they consider great improvements often complain because the railway companies do not give them proper encouragement by allowing the apparatus to be tried or by offering facilities for its development. They do not realize to what trouble and expense the roads would be subjected if they offered encouragement to the many half-hatched schemes submitted. The writer is reminded of one or two instances which are typical. Permission was obtained by some alleged inventors to try a scheme of motor control without loss in resistances and the facilities of the shop were put at their disposal.

Under their directions all the controller reverse fin-



The station after the façade was thrown down.

DEMOLISHING THE FAÇADE OF THE OLD BOSTON & PROVIDENCE TERMINAL AT BOSTON.

gers in the storeroom were mounted on long boards and a car was also brought over the pit and the fields removed from the motors. In addition quite an amount of wire was cut into small pieces. After several days of inactivity orders were received to replace the fields in the car, the so-called inventors left the shop and the incident was closed. It afterward developed that the new "invention" consisted in weakening the fields by shunting them or by winding them in sections. Operations came to a stop because a point was reached where about one hundred and fifty

EXPERIMENTS IN INGOT CASTING.

BY J. F. S. SPRINGER.

The tremendous expansion of rail transportation in the United States in recent years has imposed upon the steel-rail mills a correspondingly excessive pressure. The present plants are marvelous creations of inventive genius resulting in an almost incredible capacity of production. But it is more than hinted that their perfection of mechanical arrangement has been unaccompanied by any improvement in the quality of the rails. Indeed, Mr. R. W. Hunt, a railway expert, declared in effect at the April meeting of the American Institute of Mining Engineers (1907) that the rail process of to-day is inferior to that of twenty-five or thirty years ago. This he thought was conclusively shown by the fact that an abandoned mill of the earlier period was purchased some years ago and reinstated in the business of turning out rails. One of the railroads has about 100,000 tons of the rails made in accordance with the older methods and an equal amount of rails manufactured more nearly after the manner of the present procedure. In the matter of rail breakages, those occurring in the rails made by the older methods are but one-fourth those with the rails of the more recent procedure. If the chemical composition of the two classes of rails be taken into account, the advantage of the older methods of manufacture would be still more marked. Reheating and slowness of manufacture seem to be the main points of differentiation. But with the steel plants to-day, haste seems to be the cardinal virtue.

Profs. Howe and Stoughton have been performing some experiments in ingot casting which indicate that increased deliberation in the preparation of the steel for the rolling mills is required. Their experiments have been made not with steel, but with wax, and their object has been the investigation of the laws governing the formation of "pipes" and segregates in ingots. Not all substances form pipes. But wax and rail-steel agree in doing so. That is, each substance, when the attempt is made to cast it in the form of solid ingots, tends instead to solidify with a more or less open core along the upper part of the axis of the ingot. If this core or pipe is still in the ingot when it reaches the rolling mills, it has been pretty well ascertained that it will not be eliminated in any of the rolling processes. Consequently, it is important to learn the fundamental cause underlying its formation, as this knowledge may lead directly to such management of the casting operation as to secure either its complete effacement or a reduction to a minimum.

These two investigators have busied themselves in casting little bars or ingots of wax. Of course it would be preferable to experiment with large steel ingots of the sizes used in rail manufacture. But such experiments are rather unmanageable and very expensive. The wax-ingot experiments are, consequently, of distinct use in pointing the way that experimentation with large steel-rail ingots should take.

Further, a second large factor contributing to the imperfection of the rail-steel ingot is the presence of segregation. That is to say, the composition of the steel in large ingots is found not to be uniform throughout the mass. There is usually one locality where the carbon, phosphorus, and sulphur contained in the steel occur, not in the average degree, but con-

centrated. This concentration is the segregate. Metallurgists do not seem to entertain very strong hopes of its total prevention. At the same time, solid information as to its character and the laws of its formation can scarcely fail to lead to methods of casting favorable to a reduction of the evil.

The wax used in the experiments was commercially pure stearic acid mixed with a small quantity of copper oleate. The oleate was of a bright green color. As its specific gravity was greater than that of the wax proper, it might be expected to go to the bottom

No. 2 (if we except the small pipe at the bottom where the teeming was rapid) is about 14 per cent of the length of the ingot. If it be thought that this bottom pipe ascribed to fast pouring at the commencement of casting confuses the evidence, Fig. 3 makes the matter clear. This ingot was poured even more slowly than No. 2. The evidence afforded by these three ingots would seem, therefore, to show very clearly that slow pouring tends to efface the pipe.

The next two ingots, Figs. 4 and 5, disclose the marked advantage of casting ingots with the large end up.

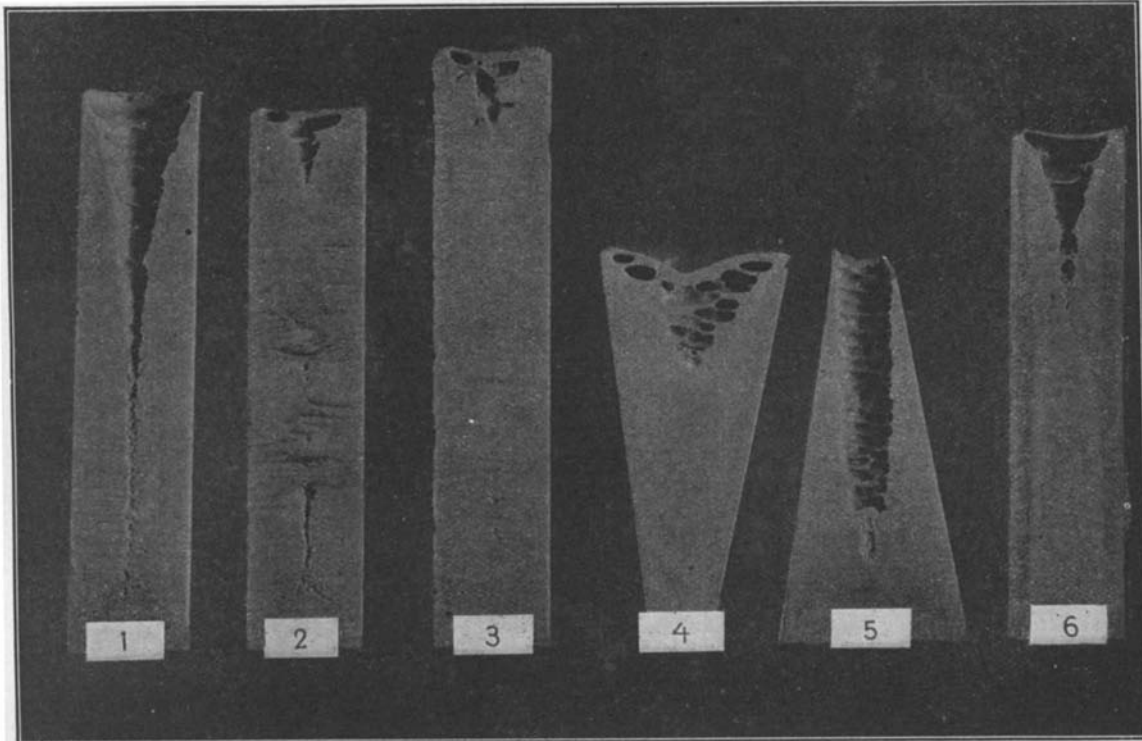

1. Ingot poured rapidly (half a minute); 2, ingot poured fast at first, but slowly afterward; 3, ingot poured very slowly; 4, ingot poured with large end up; 5, ingot poured with small end up; 6, ingot which was kept hot at top and progressively cooled at bottom.

A study of "pipes" in wax ingots.

of the ingot, if gravitation were the only influence at work. This oleate represents the carbon, sulphur, and phosphorus of the ordinary steel. Its behavior under the conditions of casting might be expected to throw light upon the segregation in steel ingots. In order to make any concentration of this green oleate markedly visible, a small quantity of red ceresine was added to the wax. This substance has, it seems, little tendency, if any, to segregation, and consequently acts as mere coloring matter, giving the stearic acid a color contrast to the oleate. It should be noticed, be-

distinctly in favor of the larger end up. The steel used was 0.50 per cent carbon. Mr. A. A. Stevenson likewise reports great diminution of piping in a steel ingot cast with the large end up as contrasted with others cast with the small ends up, all the ingots being strongly tapered.

In casting the ingot shown in Fig. 6, the top was kept in a molten condition for over an hour, while below, from the bottom upward, the ingot was progressively cooled by ice-water. Now the ingot shown in Fig. 7 was cast with these conditions of solidification pretty well reversed. That is to say, this ingot was forced to "freeze" from the top down. By comparing the two, it will be seen that there is a great contrast in the length of the pipes. The pipe in ingot No. 6 was continuous for 26 per cent of the ingot's length, but extended in a modified form for 37 per cent. In ingot No. 7 the pipe was 85 per cent of the total length of the ingot. In the engraving, the pipe of No. 7 is apparently interrupted by a "bridge" near the lower end. The pipe extends, however, through this bridge. The difference in piping brought about by solidifying from below in one case and from above in the other is indicated by the two percentages—37 and 85.

The ingots shown in Figs. 8 and 9 do not exhibit any very marked difference in piping—the pipe of No. 8 being 61 per cent while that of No. 9 is

45 per cent. The conditions were largely the same, both being cooled very slowly. The 16 per cent difference is to be attributed mainly, no doubt, to the fact that although both ingots were retarded greatly in cooling, as wholes, No. 8 was cooled from the top and No. 9 from the bottom. This agrees with the results disclosed by Nos. 4, 5, 6, and 7. Now No. 10 was cooled very rapidly, and, in contrast to the slowly cooled ingots Nos. 8 and 9, exhibits a pipe extending almost to the bottom.

In Fig. 12 we have the case of an ingot in which

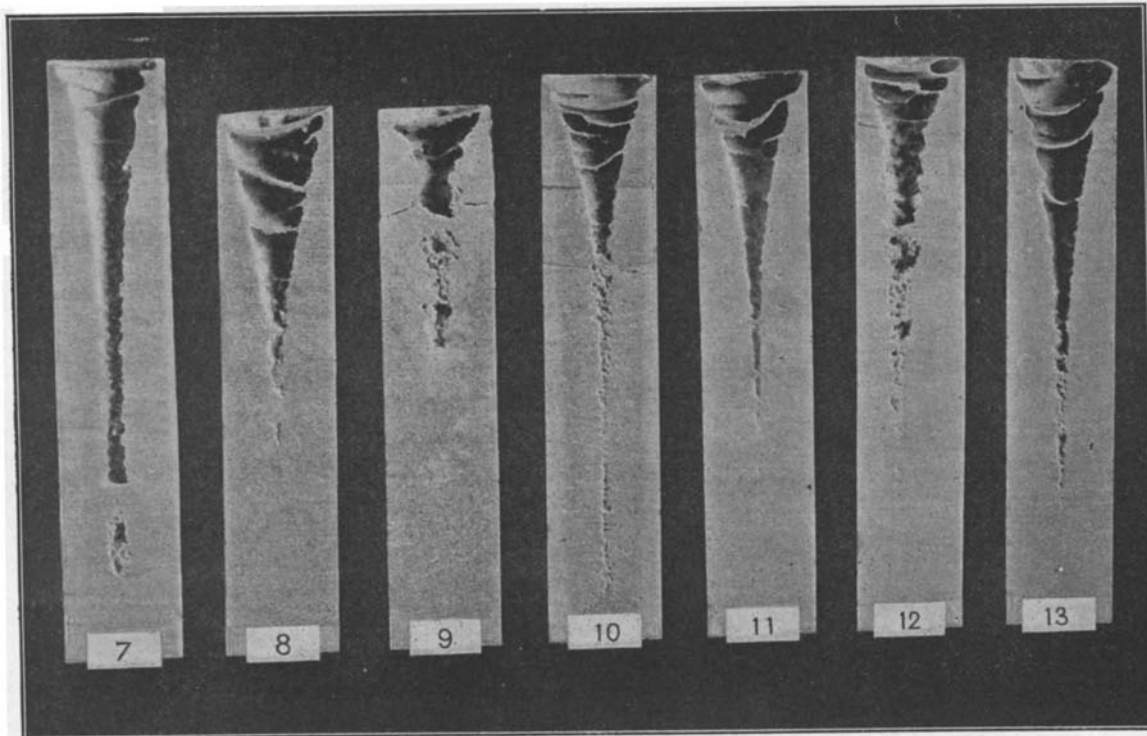

7. Ingot forced to "freeze" from top down; 8, 9, ingots cooled slowly; 10, ingot cooled rapidly; 11, ingot cooled less rapidly; 12, cooling on one side accelerated by cold water; 13, segregation in last cooling part.

A study of "pipes" in wax ingots.

EXPERIMENTS IN INGOT CASTING.

fore referring to the details of the photographs, shown in Figs. 1 to 13, that while the longitudinally split ingots of wax disclosed the color contrast, it was found necessary, in order to represent this in engravings, to retouch the photographs and then rephotograph them.

Fig. 1 is an ingot where the teeming, or pouring, was done rapidly, occupying but half a minute. Fig. 2 is an ingot poured fast at first, but with extreme deliberation afterward, the teeming occupying about an hour and a quarter. The pipe in the first ingot occupies about 90 per cent of the length. The pipe in

the cooling on the one side was accelerated by means of cold water. On the opposite side, cooling was hindered by the use of flannel. The distinct displacement of the pipe in the direction of the flannel may be very distinctly seen in the engraving (Fig. 12). Now let us gather up some of the lessons to be learned from these experiments, in so far as piping is concerned: First, slow teeming reduces the pipe. (See Figs. 1, 2, and 3.) Second, casting with the large end of tapered ingots up tends to shorten the pipe. (See Figs. 4 and 5.) Third, a top kept molten diminishes the pipe. (See Figs. 6 and 9 as contrasted with Figs. 7 and 8, respectively.)

But what of the segregate? In Fig. 1, it lies at A near the bottom. The slowness with which Nos. 2 and 3 were cast tended to prevent the concentration of the green oleate into a single segregate. There were a number of local concentrations along the axis of No. 2. In No. 3, which was cast with still more deliberation, the absence of segregation is stated to be very marked. In ingot No. 4, the segregate lies above the center, while in No. 5 it is near the bottom.

The segregate seems to display a tendency to lie in the part which freezes last. By referring to Fig. 12, where the cooling was retarded on the left but hastened on the right, the bridges E, F, and G because of the strong green coloration seem to Profs. Howe and Stoughton to mark the position of the segregate. If this be the case, though they are not unreserved in their statement, then the deflection of the segregate to the warmer side would seem pretty clear. As further evidence of segregation in the last cooling part, the cases of the ingots shown in Figs. 11 and 13 are particularly cited.

GLASS INDUSTRY OF THE UNITED STATES.

If we consider the minor factors of civilization, glass should certainly be accorded a very high place, as it enters into many of the daily affairs of life. It is one of the oldest industries in the world. Pliny states that certain Phœnician merchants were preparing a meal on the seashore, and set their cooking vessel on a mass of the sand and alkali, which, when subjected to the fire, resulted in vitrification. In all the ages glass manufacture was considered of prime importance, and was often regulated by government edicts.

Glass is a hard, transparent substance, formed by fusing together mixtures of the silicates of potash, soda, lime, magnesia, alumina, and lead in various proportions, according to the kind or quality of glass required. Silica in the form of sand is the only constituent of glass that is absolutely essential, and enters into the composition of all varieties of glass as its true foundation. Silica as sand occurs very abundantly in the United States. The proportion of silica used varies according to the character of glass desired. An increase in the percentage of silica in any glass increases the resistance to melting and fusing. The various grades of sand contain more or less impurities, which are removed or neutralized by washing or chemicals. Iron when present imparts to glass a greenish tint, which can be corrected by the use of manganese. The bases used include sodium carbonate, sodium sulphate, sodium nitrate, calcium carbonate, litharge, and potash. Other auxiliary chemicals used in glass making are arsenic, carbon, and manganese. Glass makers call arsenic the "great decarbonizer," while manganese dioxide is known as the "great decolorizer." Carbon is employed in glass making to lower the fusing point when salt cake is used as a base, and to impart color when a glass from a straw yellow to a dark amber is desired.

The question of fuel is undoubtedly the one most important to the glass maker. With the aid of a good fuel a glass maker can produce a comparatively good glass from impure materials, but he cannot make a good glass with a poor fuel, no matter how pure the materials may be. Manufacturers have naturally located where coal was cheap, or where natural gas was available. Natural gas is the ideal fuel for glass making, and as the supplies get exhausted, producer-gas is being substituted. Oil is used to some extent, but is expensive. The following figures showing the quantity and cost of materials used are from the bulletin relating to glass making issued by the Bureau of the Census for the year 1905, the latest available figures:

Materials used, total cost.....	\$26,145,522
Glass sand:	
Tons	769,792
Cost	\$1,547,147
Soda ash (carbonate of soda):	
Tons	215,462
Cost	\$4,068,804
Salt cake (sulphate of soda):	
Tons	53,905
Cost	\$802,611
Nitrate of soda:	
Tons	11,915
Cost	\$511,854

Limestone:	
Tons	115,655
Cost	\$274,209
Lime:	
Hundredweight	933,074
Cost	\$241,755
Arsenic:	
Pounds	2,676,650
Cost	\$92,574
Carbon:	
Tons	3,750
Cost	\$22,333
Manganese:	
Pounds	3,096,939
Cost	\$101,279
Litharge (red lead)	
Pounds	9,613,649
Cost	\$555,130
Potash or pearlash:	
Pounds	5,446,338
Cost	\$228,508
Grinding sand:	
Tons	410,856
Cost	\$332,013
Rouge:	
Pounds	1,098,566
Cost	\$29,869
Plaster of Paris:	
Tons	33,939
Cost	\$169,988
Fire clay or pot clay	
Pounds	42,910,286
Cost	\$290,444
Pots, not including those made at works:	
Number	9,343
Cost	\$432,591
Flattening stones:	
Number	410
Cost	\$22,266
Fuel:	
Total cost	\$6,243,006
Natural gas, cost.....	\$2,777,157
Oil—	
Gallons	18,346,660
Cost	\$526,868
Coal—	
Tons	1,488,476
Cost	\$2,748,766
All other fuel.....	\$190,215
Rent of power and heat.....	\$42,164
Lumber, casks, barrels, boxes, etc.....	\$4,750,213
Caps, metal trimmings, and rubber supplies	\$1,696,145
Supplies used in repairs on tanks and furnaces	\$741,953
Mill supplies	\$265,444
All other materials.....	\$2,192,528
Freight	\$490,594
Disregarding the processes of manufacture, which have been repeatedly dwelt upon in these columns, let us consider the finished product. The following figures are for the same period and represent a year's product:	
Products, aggregate value.....	\$79,607,998
Building glass:	
Total value	\$21,697,861
Window glass—	
50-foot boxes	4,852,315
Value	\$11,610,851
Obscured glass—	
100-foot boxes	70,774
Value	\$376,030
Plate glass—	
Total cast, square feet.....	34,804,986
Rough made for sale—	
Square feet	17,784
Value	\$3,529
Polished—	
Square feet	27,293,138
Value	\$7,978,253
Cathedral—	
Square feet	6,615,093
Value	\$293,623
Skylight—	
Square feet	15,255,541
Value	\$678,391
All other building glass, value.....	\$757,184
Pressed and blown glass:	
Total value	\$21,956,158
Tableware—	
100 pieces	1,283,974
Value	\$4,897,537
Jellies, tumblers, and goblets—	
Dozens	7,346,214
Value	\$1,639,167
Lamps—	
Dozens	487,017
Value	\$1,247,628
Chimneys—	
Dozens	7,039,756
Value	\$3,061,334

Lantern globes—	
Dozens	1,765,247
Value	\$852,823
Globes and other electrical goods—	
Dozens	1,901,415
Value	\$1,106,317
Shades, globes, and other gas goods—	
Dozens	878,244
Value	\$1,949,069
Blown tumblers, stemware, and bar goods—	
Dozens	6,282,606
Value	\$2,928,198
Opal ware—	
Dozens	1,091,208
Value	\$870,221
Cut glass—	
Dozens	83,736
Value	\$987,556
All other pressed and blown glass, value	\$2,416,308
Bottles and jars:	
Total value	\$33,631,063
Prescription vials and druggists' wares—	
Gross	3,202,586
Value	\$6,638,508
Beers, sodas, and minerals—	
Gross	2,351,852
Value	\$7,927,287
Liquors and flasks—	
Gross	2,157,807
Value	\$5,555,815
Milk jars—	
Gross	253,651
Value	\$1,160,743
Fruit jars—	
Gross	1,061,829
Value	\$3,436,047
Battery jars and other electrical goods—	
Gross	19,974
Value	\$105,632
Patent and proprietary—	
Gross	1,657,372
Value	\$3,709,510
Packers and preservers—	
Gross	1,237,065
Value	\$2,989,557
Demijohns and carboys—	
Dozens	64,450
Value	\$247,856
All other bottles and jars, value.....	\$1,860,108
All other products, value.....	\$2,322,916

We have chosen the graphical method of presentation, and have translated the quantities into mammoth jars, boxes, bottles, lamps, and chimneys. The Singer Building looks well protected from the elements in the immense bottle. The Statue of Liberty holds her torch aloft in the goblet, which symbolizes the tableware, tumblers, etc., without touching the brim. The use of oil lamps in the United States is decreasing, due to the wider use of gas and electricity, still the lamp shown represents more than a million dollars' worth. In our comparison building-glass looms up very large, the magnitude of the industry being shown by the figures. Many of the most important inventions connected with glass are due to Americans, and the industry is a typical American one.

The Current Supplement.

The great wall of China, which even to this day represents the original idea of Chin, the first emperor, is described and illustrated in the opening article of the current SUPPLEMENT, No. 1738. A. W. Gibbs writes on the smoke nuisance and the railroad. He takes up the subject in a new way and shows that the railroads must produce power with the fuel of the country through which they run, and that bituminous coal is the fuel with which the whole question must be settled. Somewhat of a novelty is the incandescent lamp device which is mounted upon the Eiffel Tower at Paris, so as to show the hour and minute. Our Paris correspondent writes on the subject. Water and salt solutions as dust preventives are discussed by Prevost Hubbard. Robert Grimshaw writes on iron-bronze alloys. Our interest in the effects of radium rays on living organisms is enhanced by the discovery that radio-activity is widely distributed in nature and that all plants and animals are influenced by radio-activity. Prof. C. Stuart Gager, of the University of Missouri, contributes an excellent article to the literature of the subject, in which article he shows the influence of radium rays on a few life processes of plants. Emil Freund tells how artificial gems have been made in the past and how they are made now. Prof. Jacob Reighard's monograph on subaqueous photography is continued. Animal fats and oils is the subject of another technological article of interest.

Correspondence.

AIRSHIP TERMINOLOGY.

To the Editor of the SCIENTIFIC AMERICAN:

An airship is either a "heavier-than-air machine" or a "lighter-than-air machine." But these are very clumsy names. Why not call the former a "pondro," and the latter a "levitar"? These words, I think, are sufficiently "regular" in derivation to justify themselves, and they are not awkward.

Washington, D. C.

AMBROSE BIERCE.

The International Aeronautic Exposition at Frankfort-on-the-Main.

The first real aeronautic exposition the world has ever seen will be held from July 10th to October 10th at Frankfort-on-the-Main, Germany.

The period from now until the opening of the exposition in July will be one of strenuous activity for the management, since the buildings and grounds are not yet completed and in order.

The Grand Exhibition Hall, with its gigantic dimensions of 130 meters (426 feet) long and 65 meters (213 feet) diameter of central dome, was erected at a cost of \$1,500,000. It is perhaps the most imposing exhibition hall in Germany, and countless numbers of inflated balloons of the ordinary round shape will be able to float freely under its great middle dome.

For the large dirigibles four huge balloon sheds are being built, one for the "Parseval," one for the Riedinger kite balloon, one for the Von Clouth dirigible from Cologne-Nippes, and one for the dirigible of Dr. Gans of Munich. A Zeppelin shed will be added as soon as the negotiations now pending with the Zeppelin interests are concluded. It may also be considered as certain that the new motor balloon of the Rhenish-Westphalian Motor Airship Company, now building in Elberfeld under the direction of the well-known aeronaut Oskar Erbslöh, will be shown in a special pavilion. Therefore four or five motor balloons will be constantly in view in Frankfort throughout the duration of the exposition.

The new "Parseval" airship of 6,000 cubic meters (211,890 cubic feet) capacity, which, since its brilliantly successful trial flights at Bitterfeld, has been put into commission, will make regular trips, carrying passengers, in the neighborhood of Frankfort throughout the duration of the exposition.

Since a great number of competitions for free balloons will be held during this time, the question of gas supply was a serious matter. This question has been most fortunately solved by the offer of the "Elektron" Chemical Company to furnish daily to the exposition free of charge 1,000 cubic meters (35,315 cubic feet) of hydrogen gas. A special track will be laid down for delivering the steel cylinders of compressed gas at the filling sheds. In this manner it will be possible to fill and refill the great balloons in their sheds directly from the railroad car without unloading the steel cylinders. Moreover, a strong current of illuminating gas will allow of the simultaneous filling of various balloons. For trial flights a level territory of perhaps half a square mile in extent has been provided near the exposition grounds.

Herr Mathis of Strasburg, who has bought the original Wright aeroplane, announces trial flights of this and also of a new Wright machine with a Fiat motor.

Trials of the Voisin aeroplanes will take place on the experimental field in Griesheim, which has been turned over to Herr Euler by the military authorities. Dr. Ing. Reissner and Herr Prof. H. Junkers have also entered flying apparatus. Furthermore, numerous models of flying machines, motor balloons, balloon sheds, etc., will be on exhibition. Instruments, maps, provisions for long balloon journeys in specially-prepared packages, methods of illumination, and special clothes for ballooning will be united in a special section.

The question of suitable attire for women has been taken under special consideration by the German Association for the Improvement of Women's Clothes, and the results arrived at will be made the subject of a special exhibition.

Of most particular interest will be the demonstration of a process discovered by the "Elektron" Chemical Company for the inexpensive production of hydrogen. A separate building will be erected for this purpose, and here may be seen the ascension of small balloons filled with the gas obtained.

An aeronautic experiment station will be erected by Prof. Prandtl, where experiments in air resistance, etc., will be conducted.

Connected with the exposition will be a recreation park, in which, among other things, will be shown for the first time the spectacle of a battle between naval and aerial men-of-war. Among the names of the guarantors who have up to the present time subscribed over \$175,000 is to be found that of Count Zeppelin, who is down for the considerable sum of \$2,500.

\$200 in Prizes for the Best Garden.

If you have a small garden and you are proud of it, the readers of American Homes and Gardens want to know all about it. For the encouragement of those who have converted an unsightly lot into a lovely, blossoming piece of ground, however small, the Editor of American Homes and Gardens offers cash prizes aggregating \$200.

The prizes are offered for the best-planted, developed and successful village or suburban gardens. The Editor and the readers of American Homes and Gardens want to know how you planted your garden and what success you had with it. You need not be a skilled writer to compete.

The unusual opportunity offered in the Garden Competition should call forth immediate and practical results. It is a project that should appeal alike to the owners and creators of gardens, and to those who want helpful hints and suggestions on the making of a small garden. For it is the home garden, the inexpensive home-grown garden, for which these prizes are offered. In other words, the gardens of the people, as distinguished from the gardens of the gardeners. Everyone may have a small garden, even if it be but a front yard, and it is precisely these home gardens which are made and tended by the family that are sought in this competition.

The Garden Competition raises the plain question, Who has the best garden? And the readers of the SCIENTIFIC AMERICAN are invited, with the utmost cordiality, to answer this question.

If your garden is a small one, so much the better. No garden is too unimportant for consideration in this competition, for the award of the prizes will be based on the merits of the gardens as gardens, and not on their size and cost.

This competition affords a splendid opportunity to give many persons pleasure by making known the beauties of your own garden to them; but it should help and stimulate others in new and other garden work, by giving them some detailed information as to the successful gardens others have created. And if one garden is good, two are better and three more so, until a whole community may be alive with this richest of rural treasures. The practical questions are, How is it done, and what can be done? These two questions, it is hoped, will be abundantly answered in the material sent in for this competition. We invite our subscribers and readers, and their friends, and the friends of their friends, who have gardens that they think of real interest and beauty, or who may possess choice bits of garden loveliness, to enter this competition.

The full conditions of the contest will be found in the May number of American Homes and Gardens.

New Experiments with Lippmann's Color Photography.

H. E. Ives has been seeking the causes of the difficulties which are encountered in the practical operation of Lippmann's process of photography in natural colors. The principal results of the investigation are the following:

The image obtained with monochromatic light is improved by using an emulsion containing less silver bromide than is usually employed. The smallness of the number of stationary waves observed in the film in previous experiments is attributed to the exclusive employment of pyrogallol acid as the developer. The tanning of the gelatine by the oxidation products of pyrogallol acid prevents the developer from penetrating deeply into the film. A much larger number of stationary waves can be detected when a hydrochinon developer is used, and it is advantageous to bleach the dark silver deposit with mercuric chloride. The purity of the reflected colors increases with the thickness of the sensitive layer. For the rendering of white a rather coarse-grained emulsion sensitized with isocol is most suitable. The whites are produced by fine particles of silver separated in development and diffused throughout the film. The colors of natural objects are most correctly reproduced by an emulsion containing silver bromide in particles rather larger than those which are most suitable for monochromatic pictures. The best thickness of the sensitive layer is 1/5,000 inch. The duration of exposure and development is of great importance.

As the fine-grained emulsion of the Lippmann plates is sensitive only for violet, and not even for bright blue, a sensitizer for blue is absolutely necessary. Isocol is the only sensitizer that was found to cover the spectrum without a gap.

As a substitute for the mercury mirror, Ives recommends a silvered celluloid film placed in optical contact with the sensitive layer. A plate of glass is heavily silvered and covered with a thick solution of celluloid in amyl acetate. After the evaporation of the solvent the plate is immersed in water, whereupon the film of celluloid separates from the glass and carries the silver with it.

Ives also obtained excellent results by combining the Lippmann process with the Ives three-color process.

Gold and Silver Coinage for 1908.

The United States government made a profit of \$10,541,371 during the year of 1908 on the coinage of silver, nickel, and one-cent bronze pieces. These figures represent the difference between the price paid by the government for the metals and their coinage value. Silver bullion purchased for subsidiary silver coinage during the past year aggregated 18,819,279 standard ounces, and mutilated and uncurrent United States silver coin of the face value of \$1,162,982 was received for recoinage. There was purchased 525,833 ounces of silver bullion for the Philippine government, the cost of which, \$295,054, was reimbursed to the United States by that government.

The coinage executed by the mints of the United States during 1908 amounted to \$197,238,377 in gold, of which \$106,182,420 was in double eagles, and \$4,829,060 in eagles of the design prepared by the American sculptor, the late Augustus Saint-Gaudens. The amount of subsidiary silver coinage was \$16,530,477, which is the largest subsidiary silver coinage executed in any one year since 1877. The amount of minor coinage was \$1,946,008. There were coined for the government of the Philippine Islands 25,003,915 pieces of silver coin, of the value of 18,131,793 pesos, and for the government of Mexico 1,397,291 silver 50-centavo pieces.

The figures showing the production of gold and silver for the past year will not be forthcoming for many months, the amount of production for 1907 having just been calculated. In that year the gold output amounted to \$90,435,700, and silver for the same period was 56,514,700 fine ounces—\$37,299,700. The total production of the precious metals of the whole world for 1907 is placed at \$410,555,300 in gold, and 185,014,623 fine ounces in silver—\$122,090,000. The consumption of gold and silver in the industrial arts in the United States amounted to \$40,727,070 and 24,369,784, respectively.

The stock of gold coin in the world on January 1st last was \$7,014,600,000; silver coin, \$3,530,000,000, and of uncovered paper, \$4,302,500,000, making the whole world's money value at that time amount to fourteen billion, eight hundred and forty-seven million, and one hundred thousand dollars.

The Distance Sense of the Blind.

It has long been known that some blind persons can move about in places that are entirely strange to them with a remarkable degree of certainty and without coming into collision with any large object. Half a century ago Spallanzani discovered that bats can steer clear of obstacles in total darkness. In order to make sure that the sense of sight was not employed, he blinded some bats, and found that they flew about as confidently and safely as before.

This experiment proved that warning of the presence of objects is received through some part of the surface of the body other than the eyes. In the case of blind persons, it was thought at one time that this warning was given by sound waves reflected by the objects, but this theory is disproved by a simple experiment. When a blind man's ears are stopped completely the sense of distance remains, although it is greatly diminished. This shows that the sense of distance is not identical with the sense of hearing and that a distinction must be made between the sense of distance and the directional power of the blind. This power depends chiefly on the sense of distance, but involves also hearing, smell, the temperature sense, and perhaps still other factors.

It is a noteworthy fact that the sense of distance is not possessed by all blind persons, but is found only in a few and to very different degrees in these. The blind possessors of this sense locate it in and near the forehead and say that the sensation is vague and somewhat resembles a light touch. From the experiments of Kunz, Woelflin and others it appears very probable that the distance sense is a function of the sensory fibers of the first branch of the nervous trigeminus, which ramifies through the face. It is still unknown whether the distance sense is served by special nerves or by fibers which also serve the pressure and other senses. An investigation of the conditions which favor this sense would be very valuable, practically as well as theoretically, for thorough development of the distance sense would make the lives of the blind far safer and more independent than they are at present.—Dr. Woelflin in Umschau.

In the production of naval stores for the year 1908, of the total 36,500,000 gallons of turpentine produced by all the naval-store producing States, the yield from Florida was more than 17,000,000 gallons; and of the total of 4,000,000 barrels of rosin, the output of this product from Florida was nearly 2,000,000 barrels. Georgia ranked next to Florida in the production of these products, yielding 1,000,000 gallons of turpentine and 10,000,000 barrels of rosin.

THE PEARL FISHERY OF CEYLON.

AN INDUSTRY OVER 3,000 YEARS OLD.

BY OUR ENGLISH CORRESPONDENT.

Oriental pearls have always been regarded as of the finest and most brilliant jewels, and have always occupied a high position, the demand far exceeding the supply. The greater part, and the most highly prized, come from Ceylon. The pearl fishery is one of the oldest industries in the world. Scientific methods have not until recently entered into its development. For over three thousand years, the pearl oyster harvest has remained in the hands of the natives, whose skill in diving has been handed down from one generation to another; and despite the great advances that have been made in the art, their primitive methods are still efficient, economical, and productive. In next week's *SCIENTIFIC AMERICAN* we will publish a description of a machine for digging oysters, which will probably be able to perform much more efficiently the work of the natives.

For years the fishery constituted a government monopoly yielding a handsome revenue, but three years ago it leased the work to a private enterprise for the sum of \$125,000 per annum. The government was probably prompted to adopt this course from the speculative character of the undertaking. Whereas formerly a bumper harvest was secured one year, realizing possibly over a million dollars, several years of barrenness followed so that the average income became comparatively small.

The fishery is jealously guarded, the season is carefully regulated by ordinances, and the oyster beds are kept under constant surveillance to prevent illegal fishing or deterioration. On the average the season lasts about a month and provides occupation for over 45,000 people. The scene of operations is the estuary of the River Modragam in the Gulf of Manaar on the northwest coast. Here the banks or beds known as "paars" are peculiarly adapted to the raising of the bivalve which thrives abundantly. The bed is a stretch of shallow water varying from 18 to 60 feet in depth and stretching 50 miles along the coast and about 20 miles out to sea. The sea bed here is clean, hard sand offering but slight

clinging security to the oysters in inclement weather. Indeed, oyster propagation is extremely dependable upon the weather. For instance, a survey showed that over one hundred thousand million young were clinging to one bank, but the facilities for their adhering were so slight that a second inspection a few weeks later found that the greater part had been swept away either by currents or the monsoon, and irretrievably lost. Under such circumstances the industry is one purely of chance.

The natural deficiencies in the sea bed must be supplemented by artificial remedies, so that the oyster spat may secure a firm hold against the severest weather. To this end the marine biological scientist Prof. Herdman, D. Sc., F. R. S., is engaged in scientific investigations to improve the conditions. In order to encourage the growth of the pearl-yielding cestode it is only possible to use certain materials for depositing or "cultching" upon the bank, to which they may adhere. The most suitable media have been found to be clean broken tiles and bricks, but as these are very difficult to obtain, experiments were made with native refuse by Prof. Herdman, but it was found to possess insufficient gravity to secure a desired deposit upon the sandy sea-bottom, and was easily and quickly swept away. The best results are now obtained from a calcareous cultch consisting of old broken bleached corals and dead shells from a beach. Prof. Herdman also advocates the utilization of the dead oyster shells themselves for this purpose. The "cultching" of the oyster beds is being carried out upon these lines.

The material has the advantage of being readily obtainable in almost inexhaustible quantities at very little cost. The area to be covered by a first installment of cultching is twenty-five square miles, upon which thousands of tons of cultch have to be dumped. The monsoons prevent this work from the middle of May to the middle of October.

Four or five months before the season commences the banks are inspected to determine whether there shall be a fishery, and to estimate the extent of the yield. This has revealed the presence of over 400,000,000 young oysters upon the Periya Paar Karai, which is a continuation of the famous Periya Paar itself, from which the greatest yields of cestodes have been gathered during the past 3,000 years. This small sized, profitable, and reliable bank lies at a depth of from 50 to 54 feet and about the limit of the capabilities of the native diver, and probably for this reason it has not received the attention in the past that its yield would suggest.

The company also first exploited the banks known as the Dutch Modragam, Karativu, and Allanturai areas. They had previously proved so poor that they became neglected. They were inspected in 1904, but were found of no value. A second survey was undertaken with the result that a fishery was effected that year which otherwise would have proved barren. It netted the Ceylon government \$300,000. In 1907 these banks yielded a gross revenue of \$350,000.

The fishery is generally carried out in March or April. A short time before this a final survey is

ers his oysters he drops over the side and quickly slides down a rope to the bed. When his bag is full he gives a sharp tug of a line and is quickly hauled to the surface where he discharges his haul and re-descends. These men can remain under water from one to one and a half minutes, and they seldom come to the surface without a full load. The oysters are placed in bags, averaged to a common size, and sealed by an officér.

A careful watch is kept on shore upon the weather, and directly the wind changes the signal is given and immediately the fleet sets sail and races home. The return of the fleet is one of the most picturesque sights in the Orient, as the accompanying illustration shows. A considerable trade was formerly transacted in pilfered gems, but owing to the stringent precautions adopted now, and the continual presence of an official on board, this traffic has practically been suppressed.

After landing, the sacks of oysters are borne off to the *kottu*, or official inclosures, where they are stored until their disposal by auction. The diver is rewarded by being given a third of his catch. As the oysters may or may not possess valuable contents he invariably disposes of them in small lots to humble speculators, who trust to luck that they may net a crop of gems.

At the auctions bids are made for oysters held in bags. Formerly bids were for parcels of 1,000, which practice involved laborious counting. The purchaser transports the load to his quarters, where if he is only a small dealer he will open them himself, but if a capitalist will hand them over to his staff. Oyster opening and searching are carried out in every part of the town and the place becomes littered with shells.

The pearls are taken to merchants whose purchases will often aggregate tens of thousands of dollars. The gems are bought by weight determined in sensitive scales with seeds used as weights. They buy and transact sales as well. The stones are bought according to their luster, fineness, and size. In addition to these merchants there are many who transact business in a small way, while the huckster is always present cutting, drilling, and mounting pearls with the

most primitive tools. Auction purchasers upon an extensive scale employ natives to open the bivalves and extract their contents, which are emptied into long vats, where they are sluiced by natives seated on the outer side of the vessels, who merely agitate the water and scour the oysters with their hands. Here again constant vigilance has to be exercised to prevent purloining of gems. Despite the care observed it is always possible for small pearls to escape into the refuse. Even this is carefully examined subsequently, as well as the oyster dried dust by being sifted through the hands.

The monopoly is required to expend a minimum of \$1,000,000 upon improvements. It realized that inspection should be carried out for ascertaining whether virgin banks existed beyond the known area. This has been partially brought about by the exhaustion of the two great fishing areas which have yielded practically the whole of the pearls found during the past 100 years. That probably there are several unknown banks is borne out by the discovery of a new paar by Prof. Herdman holding some 5,000,000 five-year-old oysters rich in pearl. In some areas the conditions are so propitious to the growth of the cestode that the spat has a severe struggle for existence. Where myriads of young bivalves appear at fairly regular intervals but never reach maturity, it has been suggested that the spat should be transplanted to more favorable areas, but here a difficult obstacle has to be overcome, since it entails the handling of millions of oysters, and in a good fishery the garnering of 100,000,000.

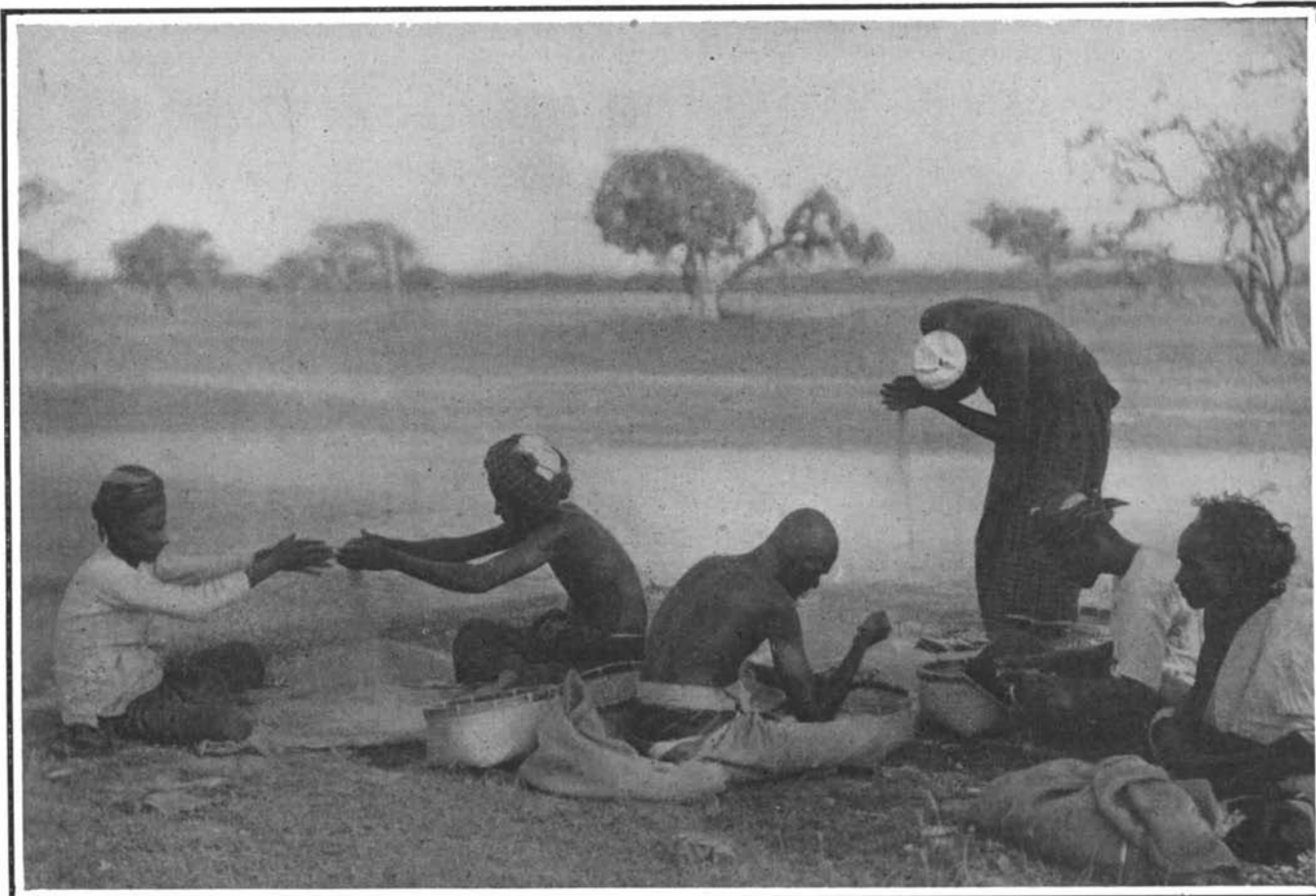

Searching for pearls in dry oyster dust at the fishery.

THE PEARL FISHERY OF CEYLON.

made and samples of oysters are tested for their yield. If satisfactory, the news is announced that a fishery will be held. It spreads like wild-fire not only through Ceylon itself but the whole of India, Malay, and up to the Persian Gulf, and the natives in these districts hurry to the island. A shanty town springs up at Marichchukkadi at the mouth of the Modragam River. It is inaccessible, practically vacant, and neglected, but in the season it is the hub of excitement. Streets of primitive dwellings fashioned of bamboo poles with a roof of palm leaves spring up, to accommodate some 45,000 natives, relieved by one or two bungalows in which agents and officials reside. The sea-front becomes crowded with a fleet of boats, some crazy and fragile, others large, roomy, and stoutly built, drawn up in one long line at anchor. Under government control no limit was placed upon the number of vessels, but now severe restrictions are imposed in order to curtail undue competition.

At this time the weather is most propitious. The sea is calm, especially during the day. Everything is carried out in methodical manner according to a strict schedule. A signal gun is fired about midnight and directly a frightful din arises from the raucous banging of tom-toms and other weird and discordant instruments beating the boat crews and divers to quarters. The keenest excitement prevails as some 300 boats strive to first reach the oyster paars.

Each boat carries native divers attired in a crude loin cloth. The diver closes his nostrils with a piece of horn and equipped with a net bag in which he gath-

In 1907, 9,000,000 of spat were moved from a rich to an impoverished bank, but it was a mere dip in the bucket. What is required is some method of economically handling the young upon an enormous scale. Dredging has been found unsuitable since it disturbs and churns up the sea-bed where the spat is lying, so that a considerable amount is destroyed. The pearl banks, it may be pointed out, are merely sand-banks formed of sandstone and concretions upon which isolated masses of coral grow without forming reefs, so that severe disturbance of the oyster bed may very easily be set up. It is found that the collection of the spat by native divers is slow but the most satisfactory.

The pearl-bearing cestode is not a true oyster for edible purposes but is more closely allied to the mussel family. It differs from the ordinary animal in

having a "byssus" or bundle of tough threads by means of which it secures a firm adherence to suitable materials, and similar to the facilities possessed by the mussel. Attempts are being made in cultivating this oyster by artificial impregnation of the pearl-forming larvæ. Investigation is being carried out to ascertain the origin of the spat, and how it periodically disappears. In connection with this research a thorough study is being made of the sea-currents on and around the oyster banks and of the surface drift in the Gulf.

The fishery is very intermittent. Prior to 1903 there had been none for twelve years, and the situation became so serious that a commission was appointed to investigate the subject. In 1905 the harvest was the greatest on record. Over 80,000,000 oysters were collected, realizing some \$1,250,000, two-

thirds going to the island's treasury. In the subsequent two years it dwindled regularly and 1908 proved barren. It is against the recurrence of intermittent fat and lean years that scientific developments are being conducted, so that the fishery each year may be of more steady and reliable proportions. By the assistance of science it is anticipated that the speculative character of the enterprise may be almost eliminated. During the past few years the tendency toward "community of interests" had developed among the natives at the auction sales. A "ring" was formed to bring prices down, at the same time keeping out small purchasers, but an officer promptly suspended the auction indefinitely. The members of the ring, apprehensive that their journey to the island would prove abortive, broke up, since which time there has never been any attempt at "combination."



Method of extracting pearls from oysters by merchants.



Examining shell refuse for pearls that escape detection in washing the oyster.

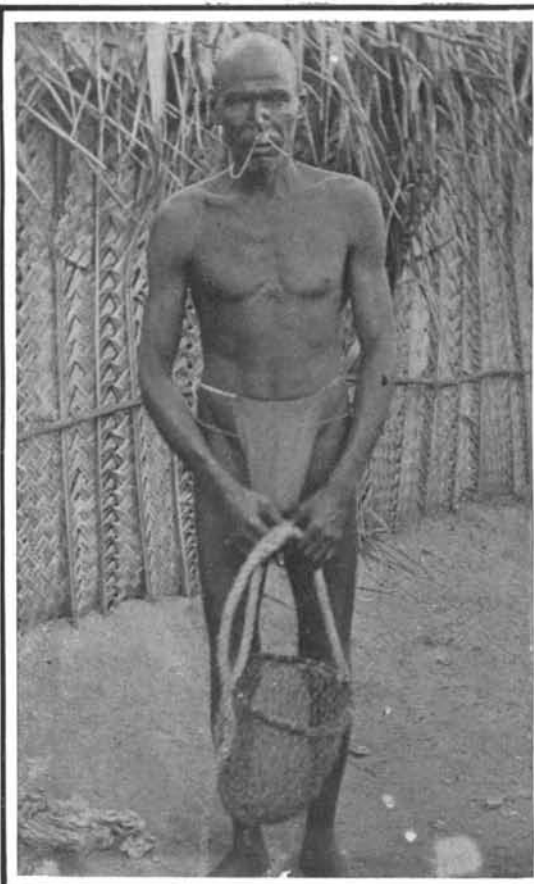

Nostrils of Arab diver closed by horn before diving.



Oyster boats coming in from the sea beds.



A native diver cleaning oysters and finding a pearl.



Counting oysters in the Goot Kottu. A process which is no longer in general use.

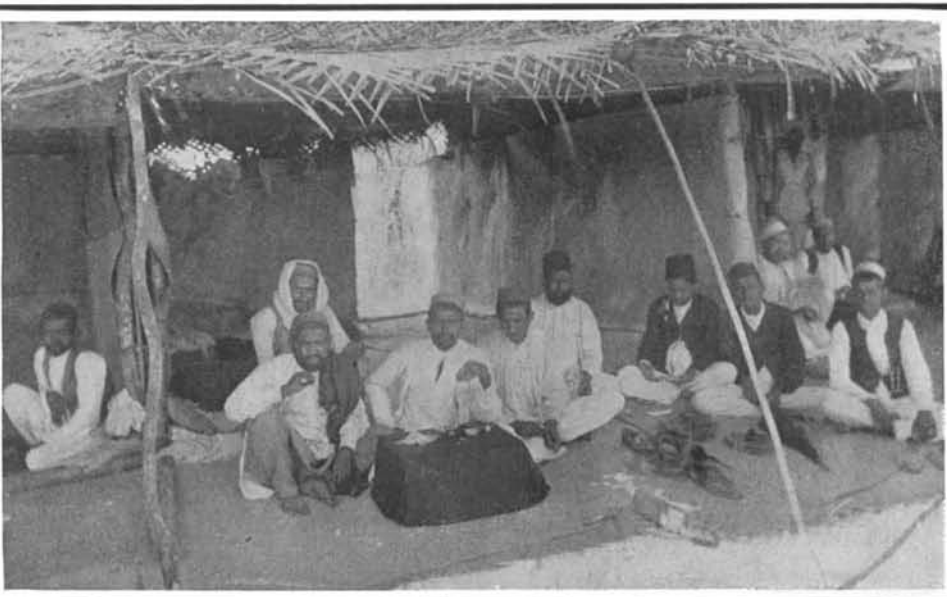

Pearl merchants weighing the gems on sensitive scales with seeds as weights.

The Dissipation of Fog and Smoke.

The experiments of Aitken have proved that dust particles play a very important part in the formation of fogs, by serving as nuclei for the condensation of water vapor. The electric and electrified particles known as ions are still more effective in condensing saturated water vapor, because their electric charges strongly attract and retain the water, thus counterbalancing the effect of surface tension, which promotes evaporation from the surfaces of drops of very small diameter. Hence ionization may produce fog and it may also destroy fog by collecting minute drops into large drops, which fall as rain.

In 1884, before Aitken's researches, Sir Oliver Lodge discovered that an electric spark discharge (which is now regarded as a stream of ions impelled by electric force) quickly dissipates smoke and dust clouds, and he has since employed the same means for the dissipation of fogs. These experiments, which have a great interest for railway and maritime traffic, are being conducted at great expense, especially in Liverpool, in the hope of keeping the suburban railway lines clear even in the foggiest weather.

About a year ago a French engineer, M. Dibos, began a series of experiments in the dispersion of fog by Hertzian waves and lately he has improved his apparatus by the addition of oxyhydrogen flames, states Cosmos. The effect produced by these flames may be partly caused by their heating the air but it is probably due chiefly to ionization, for it is well known that flames produce vast numbers of ions, or electrified particles, which become disseminated through the atmosphere.

The first decisive experiments with the flames were made on December 25th, 1908. The aerial waves were generated by an inductor of about 400,000 volts. Above the conical antenna by which the waves were emitted was placed a metal ring of smaller diameter which carried a large oxyhydrogen jet at each of the cardinal points of the compass. The four jets were connected by India rubber tubes to a central gas holder, which was supplied by a battery of cylinders containing compressed oxygen and hydrogen. The fog, which had prevailed for a week, was very thick that morning. When the emission of aerial waves commenced the oxyhydrogen flames had attained a temperature of 3,600 deg. F.

By the addition of the flames, the time required to clear the space surrounding the antenna was reduced from 40 minutes to 20 or 30 minutes and the diameter of the clear zone was greater than in the previous experiments with Hertzian waves alone, increasing from 400 feet to 500, 530, and 560 feet. The effect was maintained for nearly two hours and until the experiment was stopped by the exhaustion of the supply of oxygen. On the afternoon of the following day experiments with the Hertzian waves alone were commenced, but were discontinued in a few minutes, as the wind had shifted to the northeast and the fog was quickly dispersed by a brisk breeze from the North Sea. (These experiments were performed at Wimereux on the shore of the English Channel.)

An automobile mirror is now made based upon scientific principles. The laws of reflection and refraction are taken into proper account, so that not only is a greater volume of light projected by the lamp, but this volume is thrown just where it is wanted. The two surfaces of the mirror have curves differing in their radii the first or unsilvered surface having a deeper curve. The rays of light which strike the first surface perpendicularly pass on without refraction to the rear or silvered surface, and again reach the first surface by reflection, where they are bent or refracted. But those rays striking the mirror outside of the center do so at a greater and greater angle as the edge is approached, and are refracted more and more as the angle is increased. The marginal rays are therefore so refracted that when reflected by the silvered surface and again bent by the first surface the entire volume of reflected light is concentrated into an intense parallel beam to be directed exactly where wanted.

A HOUSE-TO-HOUSE MIRROR SYSTEM.

The idea of using mirrors to enable one to see objects without exposing one's self has found expression in more than one novel of adventure. A few patents have also been taken out for reflecting devices which render it possible to see, from a second-story room of a house, a person entering by the front door below. A New England inventor, Mr. Dana S. Dudley, has elaborated the plan on such a scale in his own town, that he is able to observe the surrounding country for a considerable distance, merely by looking down a tube mounted in his back yard.

Mr. Dudley's system may be employed for reflecting to a receiving station images of objects and persons in remote apartments of the same house or distant houses. The system comprises, as may be supposed,

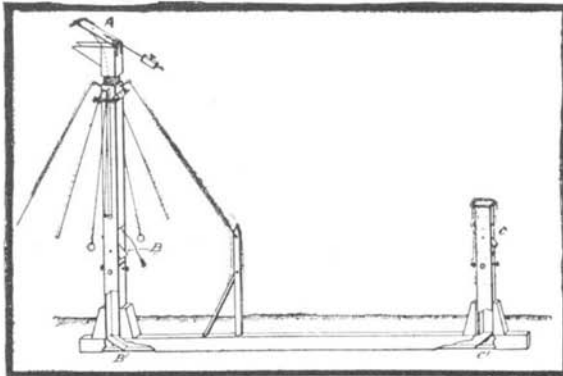
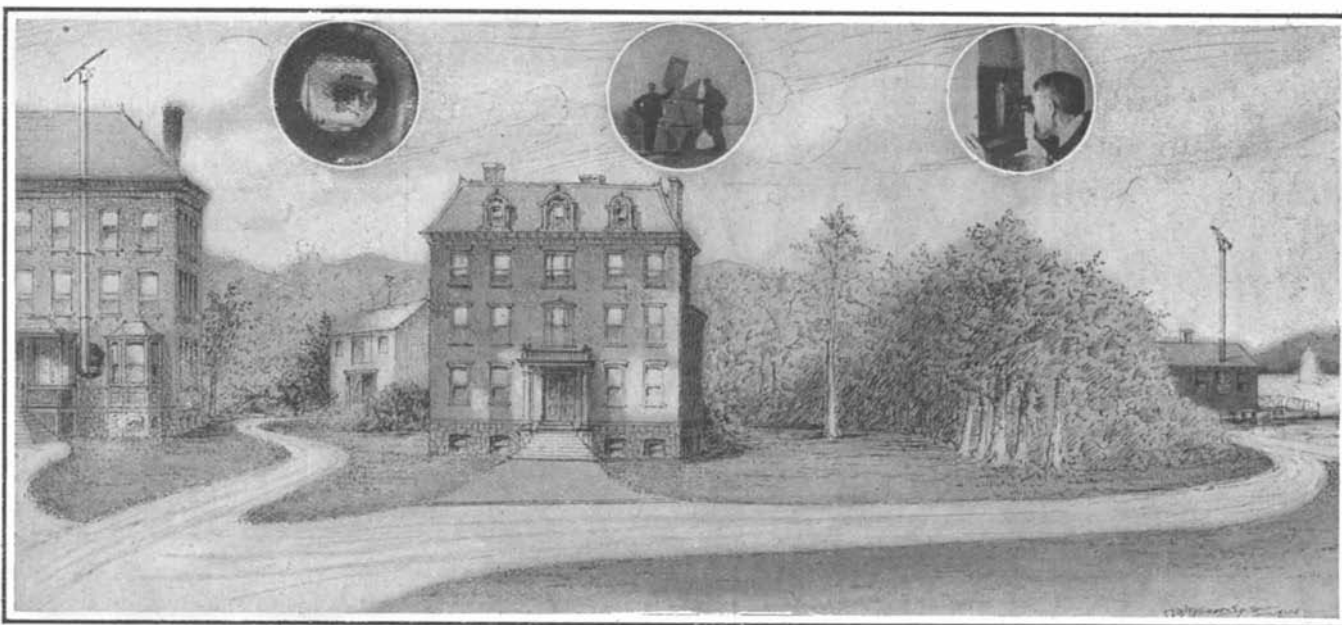

Diagram showing arrangement of mirrors and tubes.

a series of main pipes or tubes and branch tubes about a foot in diameter, which ramify a house, or which may be extended underground from one house to another beneath an intervening structure. Plane mirrors are mounted in the tubes for the purpose of reflecting the images around corners, from one tube to another. Either by electrical or mechanical means it is possible to operate a particular mirror in a particular room from a central station and cut off reflections from all other mirrors in the system, so that objects in that particular room alone may be seen. Any of the visual tubes entering the central station may be thus connected with each other.

One form of the invention (one of the simplest, moreover) is illustrated in the accompanying drawings. The object of this particular form is to render it possible to see at the point A whatever may be happening at the point C, despite the fact that a building intervenes, as shown in the drawing. At A and C, twelve-inch mirrors are mounted on ball-bearing trunnions and swiveled on a vertical axis, so that they can



The small circular pictures show respectively an image of a face transmitted through several rooms and back again; a swiveled hood on a house-top, containing a mirror; a receiving station with telescopic eye-piece.

A HOUSE-TO-HOUSE MIRROR SYSTEM.

be turned up and down and from side to side. These mirrors are designed to reflect images through tubes leading downwardly into the ground and communicating with a horizontal tube buried in the ground and passing either under or through a house situated between the stations A and C. At the points of the vertical and horizontal tubes, mirrors B' and C' are mounted at such an angle that they will reflect the image from the mirrors A and C either through the vertical tubes or through the horizontal tubes. If the image reflected to the receiving mirror is that of an object so distant that it appears very small, telescope eyepieces can be employed to magnify it, the effect being much the same as if the distant object were observed through a spy-glass.

By means of this mirror system of his, the inventor has succeeded in obtaining some very curious effects.

His arrangement of mirrors and tubes in his own house enabled him to send his own reflection through several rooms and back to himself again, so that he saw himself as if afar. He could look around the house through one lens of the telescope eyepiece and see his other eye. Two persons seated next to each other at the receiving mirror and separated by a screen could see each other clearly, after their images had been transmitted through room after room, the faces appearing remotely distant, although the two were near enough to shake hands. Mr. Dudley has also used his apparatus to reflect sunlight into cellars and dark rooms, the first mirror being so mounted that it could follow the sun's movement, as in the case of a heliostat.

Telephones can be employed in connection with this system, so that two persons may talk to each other and see each other at the same time.

A New Phonograph.

Consul Thomas H. Norton, in the following report from Chemnitz, describes a new German invention which combines the phonograph and the siren:

The methods for recording sound have reached a higher stage of perfection than those employed for its reproduction. The chief difficulty encountered in the present systems of reproducing conversation, and especially music, from phonographic and similar records, is caused by the friction of the needle resting upon the surface of the rapidly revolving disk or cylinder. This introduces a more or less noticeable buzzing or rumbling sound, which interferes materially with the clearness of musical notes or spoken words. Numerous attempts have been made to overcome this unpleasant accompaniment. In none of the devices hitherto brought forward has complete success been attained, since all involved the factor of friction as the fundamental means of transmission.

In a recent number of the Deutsche Musikwerk-Industrie, a German inventor describes a newly patented instrument, in which friction is completely avoided. It combines the leading elements of the phonograph and the siren. The novel and essential feature is the substitution of a current of compressed air for the needle or stylus of Edison's invention.

In a siren, openings of various sizes allow the production of all musical notes with any desired degree of intensity or length. In the new instrument, perforations in the disk of a siren are replaced by tangential incisions on the surface of a large record cylinder. A second perfectly smooth cylinder rests close upon the surface of the first cylinder and revolves in unison with it as the two cylinders are set in movement. A constantly varying succession of minute openings between their surfaces is presented, due to the incisions on the record cylinder. When a powerful blast of compressed air is directed upon the line of contact between the two cylinders, at such an angle as to be an exact tangent to the surfaces of both, sounds are evoked identically as in the case of an ordinary siren. It is possible to communicate signals and even words which can be readily heard miles away.

It is already evident that a field of usefulness is open to this new invention as an adjunct to the equipment of sea-going vessels. Its availability for

musical purposes has not yet been tested sufficiently to determine whether it can successfully vie with the gramophone, phonograph, etc., or even replace them.

The cylinders thus far employed are about ten times as large as ordinary phonographic cylinders, and this fact renders the instrument necessarily somewhat clumsy. The requirement of a current of compressed air may also militate against a widespread domestic use, although such a current can be supplied by a comparatively inexpensive attachment to a water tap where the water supply is under considerable pressure.

Illuminating Mass for Pyrotechnic Purposes.—Take 36 parts of nitrate of baryta, 15 parts of iron filings, 1 to 10 parts of aluminium powder, 1 part stearine, 3 parts of sugar of milk, and 3 parts of dextrine.



HOW TO BUILD A CHANUTE-TYPE GLIDER.

Many forms of glider have been tried, but the one which has so far given the most general satisfaction is known as the "Chanute" type.

Either bamboo or spruce may be used for the framework, although the latter material is the more convenient to work with.

If spruce is decided upon, the following materials will be required:

92 feet 8 inches of spruce 1 inch square in 8 pieces, 11 feet 7 inches long.

59 feet of spruce 3/4 inch square in 12 pieces, 4 feet 11 inches long.

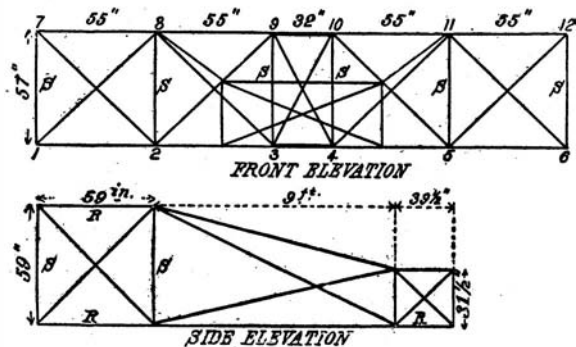

Fig. 1.—Dimensions of the frame.

57 feet of spruce 3/4 inch square in 12 pieces, 4 feet 9 inches long.

Also 50 feet of spruce 3/4 inch square in 4 pieces 6 feet 7 inches long, 4 pieces 3 feet 3 1/2 inches long, and 4 pieces 2 feet 7 1/2 inches long, for framework of rudder.

3 square feet of sheet iron 1/8 inch thick.

2 1/2 feet of mild steel rod 3/16 inch diameter.

11 dozen 3/16 inch nuts.

Ball of strong twine.

About 5 1/2 pounds of steel piano wire, No. 16.

About 40 yards of unbleached muslin 1 yard wide.

The framework should be clamped together, as holes in the sticks would seriously weaken the joints. Two suitable forms of clamp are shown in Figs. 3 and 4.

To make the clamp shown in Fig. 3, cut off a piece 8 3/4 inches long from the 3/16-inch steel rod and thread the ends for a distance of one inch, using a 3/16-inch stock and dies. Clamp the rod vertically in the vise at exactly 4 inches from one of its ends, and bend the projecting 4 inches over at right angles to the rest of the rod, using a hammer and making the bend as sharp as possible. Treat the other end in the same manner, taking care not to injure the thread on the ends. You will thus have bent the rod into the

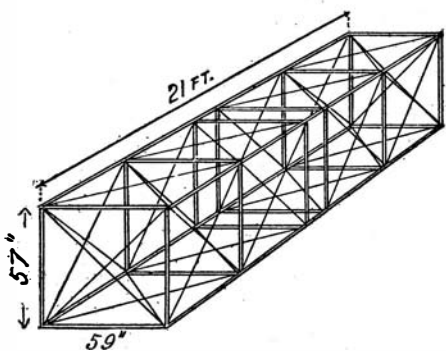

Fig. 2.—General view of main frame.

form of a letter U with a flat bottom, the sides of the U being 4 inches long and 3/4 inch apart. Take a piece of the 3/4-inch spruce and see that it fits accurately between them. Now clamp the U so formed vertically in the vise with its two legs projecting exactly 2 1/4 inches above the vise jaws. Bend them over at right angles in the same manner as before, and you will thus get the form shown in Fig. 3. For the clamp plate C cut from the sheet iron a piece 2 3/4 inches long by 3/4 inch wide.

To make the clamp shown in Figs 4 and 8 cut from 3/32-inch sheet iron a piece 6 1/2 inches by 5 1/4 inches, and then trim to the form shown in Fig. 8. As bamboo varies considerably in section from point to point, it is desirable to make each clamp to suit the dimensions of the bamboo at the point which it is to occupy. The dimensions given in Fig. 8 are therefore only approximately correct. The method of applying the clamp is shown clearly in Figs. 4 and 7; the two cross pieces of the T embrace the vertical and hori-

zontal struts, while the stem portion passes round the long horizontal rod. The clamp should be bent to shape as shown in Fig. 6, a piece of 1-inch bamboo being used to mold the circular portions. The final adjusting of the clamp should be made when it is placed in position. The two flaps of one of the T pieces pass between those of the opposite one when bolting the clamp together.

We are now ready to assemble the frame, which for convenience should be made in two sections.

Take two of the 11-foot 7-inch lengths of spruce

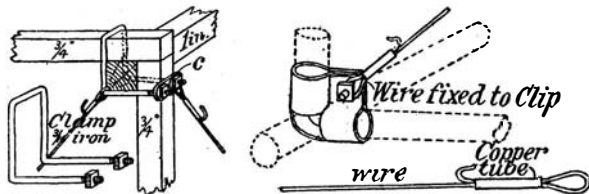

Figs. 3 and 4.—Clamps for square and round sticks.

(one being the upper edge of one side of the frame and the other the lower edge diagonally opposite) and mark off on each distances of 4 feet 7 inches and 9 feet 2 inches from one of the ends. At each of the points so found, and also at the end from which the distances were measured, clamp one of the 4-foot 11-inch and 4-foot 9-inch lengths of spruce in the manner shown in Fig. 4. To the free ends of the uprights and cross pieces attach the other two 11-foot 7-inch lengths in precisely the same manner. A rectangular cage or frame 9 feet 2 inches long by 4 feet 9 inches high will thus be formed, with the free ends of the longitudinal rods projecting 2 feet 8 inches from the end. Construct a similar cage out of the remaining rods. Place the two portions of the frame thus formed together so that the free ends of the longitudinal rods overlap, and lash each pair of the free ends together with strong twine, making the framework 21 feet in length, 4 feet 9 inches in depth, and 4 feet 11 inches wide. (See Fig. 2.)

The guy wires necessary to strengthen the frames can now be attached. Cut a number of 3/4-inch lengths of small copper tubing. Take one of these, pass one end of the piano wire through it and back again, forming a loop; bend over the free end of the wire and snip it off, leaving a small hook on the end to prevent it slipping back through the tube (Fig. 4). Pass the loop over one of the screw ends of a clamp, and run the wire to the clamp diagonally opposite,

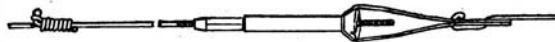

Fig. 5.—An improvised turnbuckle.

securing it there in precisely the same manner. The wires running diagonally across the frame can be fastened to the clamps by passing their ends between one of the sides of the clamp and the longitudinal rods in the manner shown in Fig. 3.

It is important that all the wires should be strained to approximately the same extent, and, as this requires some little skill to accomplish, it may be as well for the beginner to provide means for adjusting the tension of the wires after they are placed in position. An ordinary bicycle spoke introduced into the length of each wire, in the manner shown in Fig. 5, makes a good turnbuckle. One end of the divided wire is wrapped around the hub end of the spoke, the other end being secured to the spoke by a strip of thin sheet steel looped over the spoke nipple, as shown. The tension of the wire can then readily be adjusted by turning the spoke nipple.

The frame is now ready to receive the fabric. Three pieces of this must be prepared from the muslin, one 21 feet 3 inches by about 5 feet 2 inches, and the other two 5 feet 2 inches by 9 feet 6 inches. About 40 strips of spruce are required for the ribs. They should be about 1 1/2 by 1/4 inches and 5 feet long. Lay the ribs on the fabric parallel to each other and spaced at equal intervals of about one foot. Strips

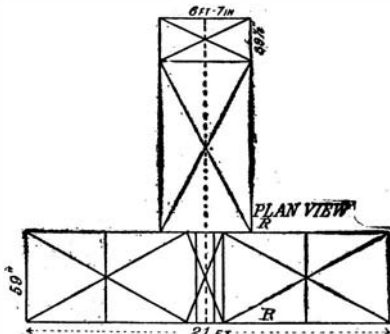

Fig. 6.—Plan view of the complete frame.

of muslin should now be laid over them longitudinally and stitched down to the fabric, thus forming a sort of pocket, open at both ends, in which the ribs can slide. The large surface with ribs in position can

now be laid on the upper deck of the frame, and the ribs lashed to the longitudinal rods by their ends at the front edge and at the point where they cross the rear portion of the frame. They will thus overhang the rear edge by about 1 foot. These overhanging portions are connected at their extremities by twine or piano wire, round which the rear edge of the fabric is lapped and glued. When this is dry the cloth can be strained into position, the front and end edges being glued to the main frame. If strong glue is used this should prove sufficient fastening, but, if desired, the fabric can be tacked to the frame as well, using small tacks. The two other pieces of cloth are secured to the lower deck in precisely the same manner, a space of about 2 feet being left between them at the center. Two pieces of spruce 3/4 inch by 1 1/2 inches should now be laid across this space from front to back about 18 inches apart and parallel to each other, and lashed to the frame with cord. They form the arm rests which support the operator. The glider is now complete with the exception of the tail, which is constructed in exactly the same manner as the main planes, the two sides, however, being covered with cloth in addition to the top and bottom. Its dimensions are given in Fig. 1. No ribs are required for the tail. It is connected

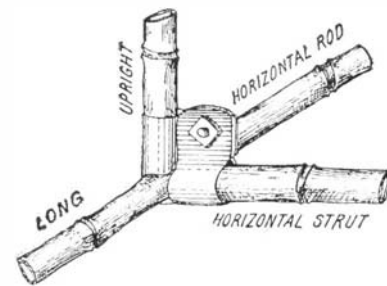

Fig. 7.—Clamp for bamboo sticks.

to the main planes by the four rectangular rods of spruce 3/4 inch square. The lower rods are lashed to the front and rear edges of the main plane about 2 inches apart, the rods being parallel to each other and spaced at equal distances on either side of the center of the plane. The other two rods are lashed to the rear edge of the upper plane and to the front edge of the tail. The tail is further braced to the main body by the piano wire in the manner shown in Fig. 1.

Curved surfaces, although not essential in a glider, can be produced in the following manner: Slightly taper the front portion of each rib for about 1/3 of its length from the front end. If the front ends of the ribs are now lashed to the frame first, and the ribs are then pushed slightly forward by their rear ends before being fastened to the rear edge of the frame, they will assume a parabolic curve. Strong glue should be applied to all lashed joints to prevent them from working loose.

If bamboo is the material selected for the frame the following lengths will be required:

- 8 pieces, 11 feet 10 inches long.
- 12 pieces, 4 feet 11 inches long.
- 12 pieces, 4 feet 9 inches long.
- 4 pieces, 6 feet 7 inches long.
- 4 pieces, 2 feet 7 1/2 inches long.
- 2 pieces, 18 feet long.

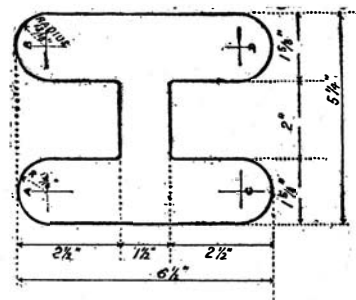

Fig. 8.—Lay-out of clamp for bamboo.

A ground suitable for the practice of gliding must have a gentle slope of about 1 in 10, if possible in the direction of the prevailing wind. If due precautions are taken, there is little danger in the art of gliding provided the beginner commences cautiously and takes sufficient time to master the balancing of his machine before attempting long glides. While learning, it is best to have two ropes about 6 feet long attached to the lateral extremities of the machine, each rope being held by an assistant. The glider is thus prevented from ascending to a dangerous height above the ground, while the novice is learning to balance it. At first there is a tendency to place the weight of the body too far back, but this difficulty is soon overcome. Steering is effected by moving the legs. To turn to the right swing both legs in that direction, and vice versa. To stop the flight, move the weight of the body backward and at the same time swing the legs forward. This will cause the machine to tilt up in front and settle down.

TOOLS FOR THE WORKSHOP.—I.

BY I. G. BAYLEY.

It is not the intention of the writer to describe in these articles all the tools necessary for a complete outfit. Such information can be obtained by studying a good tool catalogue.

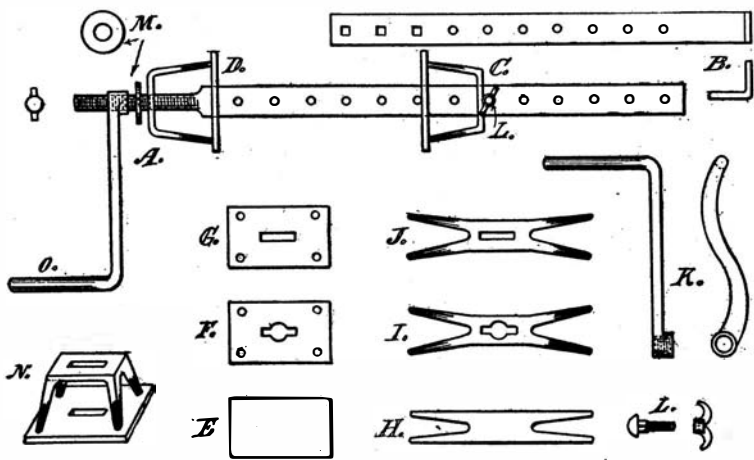

DETAILS OF THE CARPENTER'S CLAMP.

It is advisable not to take the better class of tools when called upon to do a job at a distance; for though it is commendable to make a good job of any work which may come to hand, many cases are on record where good tools have been spoiled in doing the job, which could have been done just as well with others. An excellent saw is on the market, which has the reputation of cutting through iron, nails, or hard wood, without doing itself much damage. Such a tool, with others of a kindred nature, should be put in the carpenter's shoulder chest, when called upon to do general repair work.

A CARPENTER'S CLAMP.

For holding work together while being glued or nailed, a clamp of some description is indispensable. The one herewith illustrated has the advantage of being easily made by a blacksmith or the mechanic himself.

In the illustration, A, with the extension B, shows the clamp complete. The extension B is used on large work, such as door frames. It is about 20 inches in length, after the end has been turned up, as shown, 1½ inches. The first three holes are made square to bite the thumb screw L, by which it is connected to the body A. The clamp is made of 1½ x 5/16-inch wrought iron. A is 30 inches long, including the threaded end, which is ¾ inch diameter by 6 inches long. The holes are made to suit the thumb screw L, ⅜ inch diameter. The stops D and C are identical, except that D has the slots rounded out to pass over the threaded end of the clamp, as shown in detail at I and F. Two plates are cut out as shown at E, 5 x 3 x ¼ inch, and four holes bored in the corners, ¼ inch diameter. A slot is cut in the center, large enough to slip easily over the body of the clamp. As already stated, in one case this slot must be rounded out in the center to pass over the threaded end of the clamp. Two pieces H, 3 x ¼ x 9 inches, are cut out as shown, the legs being 3 inches long, and tapered down to ¼ inch diameter. The legs are spread to suit the holes in the plates F and G, into which they are riveted, after being bent into shape as indicated in the sketch marked N.

The crank O, detailed at K, is made from a ⅝-inch diameter bar, about 15 inches in length; the part forming the handle being 4½ inches long. A boss one inch long is formed at one end, and threaded to suit the end of the clamp A. A washer M, to take up the wear, and a thumb screw L, complete the list.

A STEAM BOX.

It is sometimes necessary to bend or twist wood into various shapes, to suit certain work. Long or short strips, and even planks, can be made very pliable by steaming them from half an hour to an hour in a cheaply-constructed box, like the one illustrated. The size of the box will naturally depend upon the

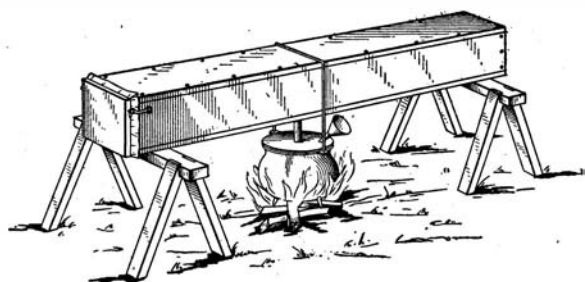

THE STEAM BOX IN USE.

class of work to be operated upon. Boxes all the way to 35 feet in length by 3 feet square have been made, for bending planks in boat building. For ordinary work, however, a box 10 to 12 inches square by 8 to 12 feet in length will be ample.

The box is made of inch boards, nailed together

with tenpenny nails, about 6 or 8 inches apart, with one end closed permanently, and the other either furnished with a hinged lid and two side catches, or left open entirely. When the latter scheme is resorted to, either an old piece of carpet, burlap, or hay can be used to close up the end. Even when the hinged lid is used, it is well to use a piece of burlap as indicated. An ample-sized pot is furnished with a wooden lid, which is made to fit the opening tightly. A hole is cut in the lid of the kettle, and the bottom of the steam box, with a compass saw, large enough to take a piece of pipe, 1½ to 2 inches in diameter.

The pipe must fit very tightly. It must be of sufficient length to prevent the box from coming too near the fire; say 4 feet from the ground.

The kettle is suspended from the middle of the box by means of a strong wire or chain over a fire. The wooden lid is furnished with an opening for a funnel to supply the kettle with water. The opening is closed with a tight-fitting cork when the funnel is not used. The box is generally placed outside the shop, within convenient reach, upon a couple of trestles or horses.

(To be continued.)

MILK TESTING WITHOUT APPARATUS.

BY PROF. GUSTAVE MICHAUD, COSTA RICA STATE COLLEGE.

The following process for the detection of added water or of skimmed milk in ordinary milk is more accurate than the simple use of the lactodensimeter without the creamometer check. The whole test can be made in five minutes. The result does not show

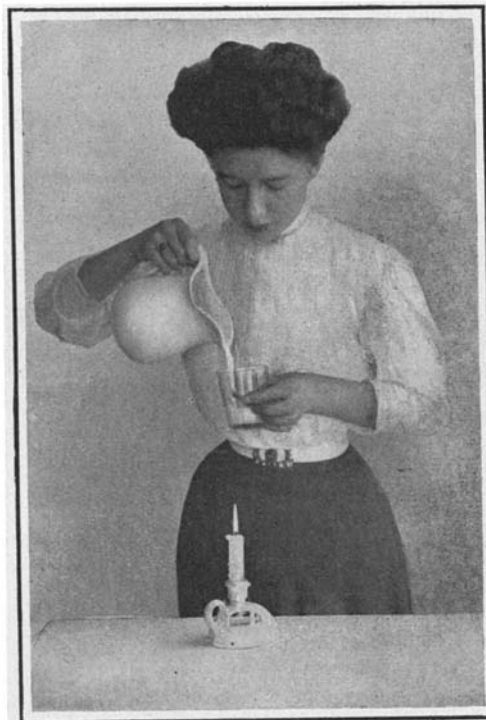

SIMPLE METHOD OF TESTING MILK.

whether the adulteration consisted in the addition of water or in the subtraction of cream, but as a rule this matters little to the consumer. What he wants to know is whether or not he had what he paid for.

The suspected milk is stirred with a spoon, in order to disseminate into the whole liquid the cream which may have come to the surface. Then one volume of milk is poured into fifty volumes of water. (One fluid ounce to two and a half pints.) A candle is lighted in a dark room. The experimenter takes an ordinary drinking glass with a tolerably flat and even bottom, and holds it right above the candle, at a distance of about one foot from it, so as to be able to see the flame of the candle through the bottom of the glass. He then pours slowly the diluted milk into the glass. (See the accompanying figure.)

The flame becomes less and less bright as the level of the liquid rises into the glass. The flame is soon reduced to a dull white spot. A little more liquid, slowly added so as to avoid pouring an excess, and the flame becomes absolutely invisible. All that remains to be done is to measure the height of the liquid in the glass, this being most conveniently ascertained by

dipping into it a strip of pasteboard and then measuring the wet part. It should measure not over one inch if the milk is pure. With good quality milk, diluted and tested as stated, the depth will be about ⅞ of an inch before the flame is lost to view. A mixture of one volume of milk and a half a volume of water should show a depth of 1½ inches. A depth of 2 inches indicates either partially skimmed milk or a mixture of one volume of good milk with one of water, and so on.

The reader has already understood that the process is based upon the close relation between the opacity of milk and the number of fatty corpuscles contained in it. Both skimming and the adding of water work in the same direction, namely, to decrease the opacity of milk. The same cannot be said of the density. Skimming increases it, adding water decreases it; and the common test, which consists in the mere introduction of the lactodensimeter in milk, is worthless, as a skimmed milk may have a normal density if care has been taken to pour into it a certain amount of water. Density should be taken before and after skimming, and the percentage of cream should be determined with the creamometer. Thus applied, the density test requires a lactodensimeter, a thermometer, and a creamometer, and the test requires twenty-four hours, while the result is not much more accurate than the opacity test just described.

SOME INTERESTING MODELS.

An exact reproduction of the apparatus used by Oersted and Faraday in their pioneer electrical work has just been prepared by Mr. Joseph G. Branch. The models show all the fundamental principles of electricity. Faraday's disk is well known in schools and colleges, but this is probably the first time in which a complete set of exact reproductions of the original apparatus used by Faraday has been made. Mr. Branch has studied copies of the original notes of Faraday and has endeavored to make perfect copies of the apparatus. Faraday's ring is not only the exact size of the original ring, but is made of the same kind of iron and the winding is similar. With this ring all the principles of the transformer can be clearly

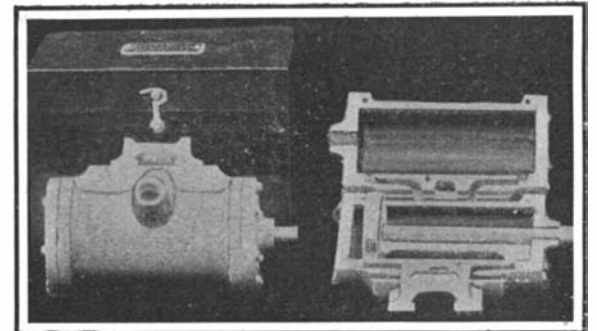

MODEL OF A "D" SLIDE VALVE.

shown, and it is so sensitive that it can be used with the ordinary pocket compass. As shown in the illustration the set is furnished with a compass galvanometer, and also with a millivoltmeter which reads to 50 millivolts on each side of the scale. There are seven models in the set illustrating relations between magnetism and electricity; how magnetism is converted into electricity; how electricity can be produced from magnetism; how one current induces a secondary current; how electricity can be produced by the expenditure of mechanical energy; and how mechanical energy can be produced from an electric current. In addition to these models Mr. Branch has prepared two engine-valve models, one of which is shown herewith. These models illustrate all the leading principles of the D slide valve and the piston valve. They are dissectible, so every detail may be examined.

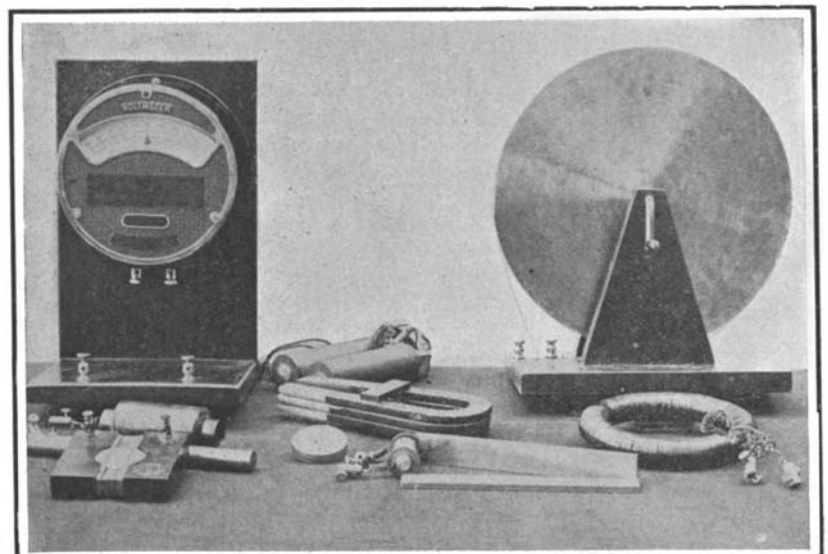

EXACT REPRODUCTIONS OF FARADAY'S AND OERSTED'S ELECTRICAL AND MAGNETIC APPARATUS.

RECENTLY PATENTED INVENTIONS. Pertaining to Apparel.

SKIRT GAGE AND MARKER.—EMMA A. HOWARD, Colorado Springs, Colo. The object of this invention is to provide a gage and marker arranged to permit accurate obtaining of the intended bottom line on the skirt without assistance, and to permit of marking the skirt for folds, tucks, and trimmings. An initial row of pencil marks is laid out by the use of a specially constructed marking device on the dress, a short distance down from the waist line and while the dress is worn by the woman for whom it is intended, and then a bottom line of marks and along which line the dress is finished as to its length.

METHOD OF OBTAINING THE CORRECT LENGTH OF SKIRTS.—EMMA A. HOWARD, Colorado Springs, Colo. In this case the method consists in first producing a row of marks on the skirt at about the hip line and at a uniform distance from the floor while the garment is supported on the wearer, and after the skirt is removed, producing a second row near the bottom a uniform distance from the first row. The invention relates to dress-making, and enables a woman without assistance, to obtain the correct length of a skirt for her own use, and also permit of marking the skirt for folds, tucks, and trimmings.

SHOE.—C. F. HELFLINGER, Taylor, Wash. The purpose of the inventor is to provide details of construction for a shoe, adapted to wear by persons of either sex, which enables the donning of the shoe in a speedy and convenient manner, and its removal readily when desired. It will fit snugly, will be waterproof at the closure joints thereof, and may be quickly secured by a shoe string without tying the latter.

Electrical Devices.

UNDER-GROOVED TROLLEY-WIRE.—L. STEINBERGER, New York, N. Y. The contact face of the wire which is protected from weather, has a plurality of bearing surfaces insuring contact of considerable area. The wire can be readily substituted for other kinds. The wire is made up from a minimum of metal for the amount of contact surface. It is of a conformity which enables it to be readily suspended from clips; its shape is such that the trolley easily engages it, and the trolley wheel cannot be readily misplaced from the wire when once in contact therewith.

THIRD-RAIL INSULATOR.—L. STEINBERGER, New York, N. Y. The more particular object of this inventor is to provide an insulator suitable for use in connection with third rails and in analogous relations where heavy conductors are employed. Among many advantages, one is in the provision of an insulated rail support presenting a relatively small mechanical contact surface to the rail, thereby allowing the rail free movement and avoiding the possibility of the rail binding on its support by rusting, freezing or otherwise, and thereby bending or breaking it.

SHEAVE.—F. JONES, C. M. BROWN, J. S. FLEMING, and W. L. McDONALD, Plymouth, Ohio. In view in this case is a sheave provided with a grooved rim substantially centrally divided on a plane at right-angles to the axis, forming the entire rim into two separable half sections, each rim section having an internally-projecting flange, a hub portion, and means carried by the hub portion, separable therefrom and from the rim, and having marginal openings engaging flat against the outer surface of the flange of each rim section, forcing the inner faces of these flanges together.

TROLLEY.—A. S. JANIN, New York, N. Y. This trolley has a collapsible diamond-shaped frame, spring and pneumatically operated, and so designed that it will readily operate at all times, especially when used in high speed work and with heavy traffic. The trolley is under complete control of the motorman, and will not leave the wire without being purposely withdrawn.

DRY-BATTERY CELL.—W. S. DOE, Jersey City, N. J. The object here is to provide certain improvements in dry battery cells, whereby the exciting fluid usually discharged from the battery filling when the battery is in use is stored and reused when in an effective manner, to increase the life of the battery and to render the same very effective at all times.

Of Interest to Farmers.

COTTON-CLEANER.—S. WILLIAMS, Texola, Okla. There is provision here for a device in which seed cotton in various states of cleanliness can be treated and then passed directly into the gins. It is a well known fact that the less the cotton is handled to put it into condition for the spinner, the better, since in the various cleaning operations, the fiber is apt to get broken, thereby impairing its usefulness.

CORN-HUSKER.—H. S. BLAIR, Bucyrus, Ohio. The aim of the improvement is to so connect the hook with the palm plate, that it may be moved from side to side and turned to varying angular positions within certain limits and secured to the plate in any position of its adjustment within these limits, whereby it may be relatively disposed on the palm plate to suit the motion of the user.

Of General Interest.

AUTOMATIC PIANO.—F. R. GOOLMAN, Binghamton, N. Y. The purpose of the invention is to provide a piano, and means electrically operated or operated by a coin, whereby to set the instrument in action, the piano acting automatically to complete any tune commenced. Further, to provide a device attachable to any piano of any type, which will render the action of the piano automatic.

DRY MEASURE.—G. W. LYONS, Grand Rapids, Wis. This measure is for use for measuring vegetables, cereals, and like goods, and permits convenient filling of the measure from the top with goods, and at the same time the measure is hung from a barrel or like vessel, containing the goods, or to allow filling the dry measure from the bottom when measuring cereals contained in a bin, barrel, etc., and convenient discharge of contents of the measure by way of the bottom.

SHEET-METAL VESSEL.—J. HÖLAND and K. J. HALLELAND, Stavanger, Norway. This invention is an improvement in sheet metal vessels more especially constructed for containing preserved foods, and has in view the provision of a seam between the can body and can head such that the can will be hermetically sealed without the use of solder and along which seam the can head and body are readily separable.

METHOD OF EXTRACTING TREES AND STUMPS FROM THE SOIL BY MEANS OF EXPLOSIVES.—G. HUNTER, Victoria, British Columbia, Canada. The object of the invention is to so bind a tree or stump that when an explosive is used for its removal in the ordinary way, by putting it into a hole under the tree or stump, it will direct the expanding gases downwardly to expend their energy on and about the roots, thereby extracting them in their entirety without unnecessarily tearing the tree apart.

PIPETTE ATTACHMENT.—A. E. HUTCHINSON, Victor, Colo. This invention is directed to improvements in pipette attachments, embodying a construction easily operable to draw into the pipette when applied thereto, any required quantity of liquid and eject the same when desired. The operation is such that the admission of the liquid to the pipette can be gaged with minuteness, making the invention particularly desirable where precision is required.

SELF-PROPELLED TORPEDO.—A. E. JONES, Fiume, Austria-Hungary. The object in this instance is improvements in torpedoes, and relates more particularly to the automatic expulsion of the leakage water, by utilizing the sinking valve itself, and also the protection of the gyroscope and its accessory parts from the harmful action of the said leakage water.

CONTROLLING-VALVE.—E. ENGREBRETSON, Devil's Lake, N. D. The valve is adapted for operation in a substantially automatic manner for controlling the supply of tensional fluids; and the object of the inventor is to provide a valve having adjusting means whereby its position may be varied relatively to the ports controlled by it, independently of the parts in connection with which the valve is used.

Hardware.

SHUTTER-HINGE.—J. B. WRIGHT, Greensboro, N. C. In this hinge the leaves are reversible with respect to each other, thus permitting the hinge to be applied at either side of the blind or shutter. In opening a shutter provided with this hinge, it is not necessary to lift the former, and the shutter is securely locked in its open position. To close the shutter the yoke connected with the hinge is lifted, thus freeing the shutter and permitting it to swing in closed position.

SAFETY-RAZOR.—C. GRABHORN, Hoboken, N. J. The intention of the improvement is to provide a razor, arranged for use in quickly folding the parts into an exceedingly small space when the razor is not in use, and when folded the razor can be conveniently and safely carried in a vest or other pocket, and when extended is ready for use for its legitimate purposes.

LOCK.—A. M. H. DE BRUYCKER, New York, N. Y. The object of the invention is to provide a lock having a bolt formed of hook members, capable of being moved in the direction of their length and adapted to be spread apart to engage the keeper with the hook ends, thus holding the bolt pivotally against retraction unless actuated by the proper key.

Heating and Lighting.

OIL AND GAS FURNACE.—J. W. RUSSELL and T. E. NEXLON, Renovo, Pa. The furnace is adapted for using oil or gas as a fuel for heating bars, frames, or other parts of iron construction, and particularly for welding engine frames. The chief object in view is the production of a furnace distinguished by strength and economy of construction, and in which refuse oil may be burned with efficient result.

GAS-FIXTURE.—A. JARMOLOWSKY, New York, N. Y. The invention contemplates a tubular gas lighter in communication with the valve casing and revoluble and vertically movable around the several lights fed from the casing, the lighter having a valve within the

casing adapted to seat on the gas inlet and thus operate to simultaneously extinguish all lights. It has reference to improvements for which Letters Patent were formerly granted to Mr. Jarmolowsky.

Household Utillies.

INDICATOR.—W. SCHNITZSPAN, New York, N. Y. In this patent the object primarily is to improve and simplify the construction of the present form of indicator, especially the hands or pointers employed, which are made of springy sheet metal and bent into a novel shape insuring against any accidental displacement from looseness when assembled.

Machines and Mechanical Devices.

TANNING-MACHINE.—F. H. YOCUM, London, Ontario, Canada. The tanning is attained by alternately dipping the hides into and removing them from a vat of liquor, and in so arranging the hides that they will pass through and emerge from the liquor in a separated condition, but while out will be in a packed condition, which assists in expressing the liquor from the hides, thus subjecting them to an alternate injection and expression, to cause the liquor to more easily enter their pores, and to change the liquor at frequent intervals.

CONTROLLING DEVICE FOR ELEVATOR-BRAKES.—W. H. C. BRENNER, Poughkeepsie, N. Y. The purpose of this improvement is to provide details of construction for a brake rope controller, whereby the rope will be pulled upon by the upward travel of the elevator platform, and automatically stop the platform at a desired point, that will render the platform level with the floor of the building in which the elevator is installed.

TRIMMER FOR LOOPERS.—W. J. STEERE, Rockwood, Tenn. The object of the invention is to provide a trimmer forming a permanent attachment for a looper and arranged to accurately cut off the surplus material above the loops held on the looper points, to direct the surplus material from the machine, and to remove all lint or other extraneous matter from the seam of the knit fabric.

MACHINE FOR CALKING HORSESHOES.—G. H. SMITH, Great Falls, Mont. The invention in this case is to produce a machine which can be operated so as to effect the operation of inserting calks in horseshoes, threading the shoes, and also providing means for holding the shoes, while the machine is operating upon them. It can be also used to remove worn calks from shoes which are being repaired.

TREADLE MECHANISM.—H. W. LODER, New York, N. Y. The aim of this inventor is to provide a mechanism for use on sewing machines and the like, and arranged to permit convenient and quick adjustment of the treadle, to suit tall or short persons, with a view to enable the same to actuate the machine with the least physical exertion and with the greatest comfort.

KNOTTER FOR COP-WINDING MACHINES.—S. J. MARTIN, Saltillo, Mexico. In cloth factories where cop winding machines are employed, it is necessary to join the ends of the thread to be wound on the cops, which operation is usually performed by hand by tying the ends together. This is a slow and tedious operation, the knots frequently coming untied, or the ends of the thread beyond the knot are not of uniform length. The attachment ties the knots in a safe and rapid manner with a uniform length of ends.

AUTOMATIC SCALE.—A. H. AUSTIN, New Rochelle, N. Y. The device is so constructed that when set to the required weight, and a feed mechanism interposed between the hopper and the scale pan has been adjusted, the material will pass freely from the hopper to the pan until the required weight has been obtained, whereupon the supply of material from the feed mechanism is automatically reduced until when the weight has been obtained the feed mechanism is automatically completely cut off, the controlling factor being electricity.

Railways and Their Accessories.

SAFETY APPLIANCE FOR RAILWAY-CARS.—R. BELDEN, Spanish Ranch, Cal. One purpose of this inventor is to provide an appliance for use for railway cars, or trains of cars, that will act to effectually prevent the cars leaving the track, particularly at abrupt curves, and will also serve to prevent the flanges of the car wheels from having undue frictional engagement with the rails.

Pertaining to Recreation.

ROLLER-SKATE.—T. S. PACIE, Chicago, Ill. The present invention has for its purpose to provide for a movement between the foot plate and rollers with greater ease, and also for the convenient removal and renewal of the cushion, as well as produce a stronger construction. This is accomplished by placing the cushion between the foot plate and roller spindle and pivotally connect these parts in a way such that the opposite ends of the spindle are adapted to swing to and from the foot plate against the action of the cushion.

NOTE.—Copies of any of these patents will be furnished by Munn & Co. for ten cents each. Please state the name of the patentee, title of the invention, and date of this paper.

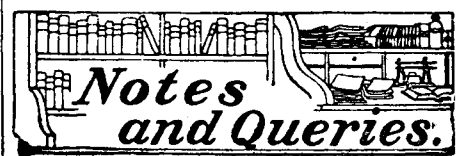

Kindly write queries on separate sheets when writing about other matters, such as patents, subscriptions, books, etc. This will facilitate answering your questions. Be sure and give full name and address on every sheet.

Full hints to correspondents were printed at the head of this column in the issue of March 13th or will be sent by mail on request.

(12067) H. D. R. asks: My friend claims that when ice is freezing in a river or pond, it first freezes in small particles "of ice" down in the water near the bottom, and then rises up to the surface and freezes solid, and I claim that it does not. Who is correct? A. Ice does not form below the surface of water and rise to the surface. Water at 39 deg. is heavier than at any other temperature. As water cools below 39 deg. it remains on the top, and the water at the surface is colder than anywhere under the surface after 39 deg. is reached. Hence water first reaches 32 deg. at the surface, and ice forms there.

(12068) J. A. B. asks: In carefully reading "The Forms of Water," by John Tyndall, I find the following startling statement (Sec. 56, page 153): "Hence to convert one pound of tropical ocean (water) into vapor the sun must expend 10,000 times as much heat as would raise one pound of iron one degree in temperature. This quantity of heat would raise the temperature of 5 pounds of iron 2,000 degrees, which is the fusing point of cast iron; at this temperature the metal would not only be white hot, but would pass into the molten condition." Can this be actually true? If so, would it not be safe to say the quantity of heat generated in the kitchen stove to thoroughly cook a 7-pound pot roast, where more than a pound of water is converted into the form of vapor, would be sufficient to melt 5 pounds of cast iron? Would any rational person believe you? Why would not this enormous quantity of heat melt down the top of the stove? A. The statement you quote from Tyndall's book is undoubtedly true. It is explained by the well-known phenomenon of the latent heat of steam—the amount of heat required to turn a pound of water at 212 deg. into steam at the same temperature. The amount of heat required to boil your pot would undoubtedly burn up the top of the stove if it could be sufficiently condensed both as regards time and space, i. e., if it were not being constantly radiated away by the large surface of the stove, used up in boiling the water, etc. 2. Again, in a recent article on the Panama Canal in the SCIENTIFIC AMERICAN, one objection made to a sea-level canal was that the rush or flow of water caused by the 10-foot difference in the level of the two oceans would have to be taken into account. Now I thought that the old "difference in level" doctrine had long been disposed of, and that the mean sea level was the same on both sides of the Isthmus of Panama. No doubt the writer referred to the tide, but he did not say so, neither would his article suggest the tide at all, as the cause of the difference in level. What is the maximum of high tide at Panama or Colon? And which direction would the tide take through the canal, were a sea-level channel to be made? A. The "doctrine" of the difference of level between the oceans at Panama has not yet been "disposed of." It is a little difficult to dispose of a physical fact of a few million square miles of ocean with a surface 9 feet higher than that at the other end of the canal. The difference of level referred to is caused by tide; it does not cease to be a difference of level on that account. The current through the canal would be nothing very serious; 9 feet head in 42 miles is not much; but in conjunction with a number of other conditions, the filling up of a sea-level canal by detritus from the Chagres River, etc., the daily reversal of a flow of that extent is a matter for serious consideration. The mean sea level is approximately the same at both ends of the canal, but the amplitude of the tide has a maximum of 2 feet at Colon and of 20 feet at Panama. That is to say, supposing the tides to synchronize, low-tide level at Colon may be 9 feet higher than low tide at Panama, and high tide at Panama 9 feet higher than high tide at Colon. The flow from one end to the other of a sea-level canal would be reversed with each mean tide.

(12069) E. G. de C. asks: I beg to refer to you for elucidation a certain point in engineering, feeling certain that you will help me with your kind assistance. Two eccentrics are hitched on to a slowly-revolving shaft, 2 r. p. m. The eccentrics are respectively 4 inches and 8 inches in diameter. To each is attached a rod, connected at the opposite end to a sliding plate, which moves in a horizontal plane. Each plate is perforated with a slot, 4 inches long and 1/4 inch wide. The length of the slot is at right angles to the plane of motion. The slots are so regulated that at the end of each stroke of the eccentric, each slot is exactly under a corresponding slot of the same size, which opens the tapering end of a hopper full of sand,

placed vertically above the sliding plate. Supposing each hopper to be alike, and filled with the same amount of the same grade of sand, what will be the proportion in the rate of flow from the two hoppers? In other words, will the two hoppers be emptied in the same length of time, or in the inverse ratio of the diameter of the eccentrics? I trust that I am not imposing too much upon your kindness, and thank you beforehand. A. As the slots in the sliding plates coincide with those at the bottom of the hopper at the end of the stroke of the former, the time during which the sliding slot coincides with the fixed one will be practically the same for both slots in spite of the difference of diameter of the eccentrics. Were the points at which the slots register in the middle of the strokes of the sliding plate, the plate operated by the 8-inch eccentric would be traveling twice as fast as that of the 4-inch, and the slot would therefore be open half the time and half the quantity of sand would be discharged; but as the speed of the sliding plate is variable, due to the conversion of rotary to sliding motion, and both plates must come to rest at each end of their strokes, the period during which each is at rest will not be measurably different. It is probable that in a long continuous run a little more sand would be found discharged through the plate operated by the 4-inch than by the 8-inch eccentric, but the quantities discharged would not differ by an amount approaching the inverse ratio of the strokes.

NEW BOOKS, ETC.

RUGS ORIENTAL AND OCCIDENTAL, ANTIQUE AND MODERN. A Hand Book for Ready Reference. By Rosa Belle Holt. Chicago: A. C. McClurg & Co., 1908. Quarto; 202 pp. Price, \$5.

Since the first edition of this book was published, circumstances connected with the buying and selling of Oriental rugs have changed, and the number of reliable authorities has increased considerably. The illustrations are of the highest possible order. They are some of the finest examples of color printing which have been brought out in years. The frontispiece is a magnificent reproduction of a beautiful antique Tabriz silk rug. The other plates are equally fine, and will be a great treat to all lovers of rugs. The work begins with the history and details of rug weaving, then the subject of rug weaving in Egypt, Persia, and Turkey is taken up, followed by a description of rug weaving as conducted in India, Afghanistan, Beluchistan, Central Asia, and the Caucasus region. Then miscellaneous Oriental rugs are treated, such as rugs of the Holy Land, Chinese rugs, Japanese rugs, Polish rugs, silk rugs, felt rugs, prayer rugs, hunting rugs. Rug weaving in Europe and the United States is treated separately, the European countries being Greece, Morocco, Spain, Bosnia, Servia, Roumania, Bulgaria, England, and France. The last chapter, giving miscellaneous information, takes up the question of inscriptions on rugs, Oriental symbols, Chinese symbols, Japanese symbols, Persian symbols, Turkish symbols, miscellaneous symbols, and the meanings of some of the place names associated with rugs. There is also some valuable geographical data and an excellent list of authorities.

THE OCEAN CARRIER. By J. Russell Smith, Ph.D. New York: G. P. Putnam's Sons, 1908. 12mo.; 344 pp. Price, \$1.50 net.

At last we have a history and analysis of ocean transportation with a discussion of its rates. This book fills a very much neglected niche in the history of transportation. It is the outgrowth of the study of three questions: The development of line traffic; the combination among carriers to control rates, and the combination of steamship lines and railways. Numerous writers have dealt with the activities of the ocean, which is a fascinating subject. Biographies of men and of ships, technical details of ships, appear to have been the interesting things. Who built the ship; just when; just where; how long she was to an inch; how wide; how deep; the material; the tonnage; the exact size of her engines; the number of strokes per minute, her speed; her best voyage-record; who captained her, etc. Such information can be collected by the volume, but there is an astonishing silence in the pages of the past as to what these wonderful ships actually did and how much they paid; what they carried; where they carried it; for whom; under what method of management, are things rarely, if ever, told by writers of maritime topics. Such records do, however, exist, as incidental statements in a wide variety of documents, and the present work takes up this information in the most painstaking manner. From the immense mass of materials available, the author traces out the main lines of past development and detects the dominant factors in the present situation. The book is well illustrated by carefully chosen engravings of vessels, and by excellent maps dealing with the great trade routes and the activities of the great steamship companies.

THE WONDER BOOK OF MAGNETISM. By Edwin J. Houston, Ph.D. New York: Frederick A. Stokes Company, 1908. 12mo.; 325 pp. Price, \$1.50 net.

The purpose of "The Wonder Books of Science" is to bring home to the young reader the fascination of the marvels of nature, and to explain the wonderful laws which govern them

The author is singularly happy in getting the point of view of the youthful reader. Having been, during his life, a practical scientist and a successful teacher of boys, he combines the most desirable forms of experience. In this book the author tells of magnetic batteries and magnetic currents; lodestones; magnets that remember and magnets that forget; the compass, the curious causes of its variations and the methods of preventing them; peculiarities of the earth's magnetism; the Auroral Lights; the telephonograph, or talking newspaper, and many other marvels.

GLASS MANUFACTURE. By Walter Rosenban, B.A., B.C.E. New York: Van Nostrand Company, 1908. 12mo.; 264 pp. Price, \$2 net.

The present volume on glass manufacturing has been written chiefly for the benefit of those who are users of glass, and therefore makes no claim to be an adequate guide or help to those engaged in glass manufacture itself. For this reason, the account of manufacturing processes has been kept as non-technical as possible; no appliances have been given, and only a few diagrams have been introduced for the purpose of avoiding lengthy verbal descriptions. There are few industries where the processes of manufacturing are kept more secret, so that the path of the author who would give an accurate account of the best modern processes used in any given department of the industry, is beset with great difficulties. The author has endeavored to steer the best course open to him under these circumstances, and he appeals to the paucity of glass literature in the English language as evidence of the difficulty to which he refers. The physical and mechanical properties of glass are first taken up, then the raw materials of glass manufacture are treated, which is followed by a chapter on crucibles and furnaces for the fusion of glass, the process of fusion, processes used in the working of glass, bottle glass, rolled or plate glass, sheet and crown glass, colored glasses, optical glass, and miscellaneous products.

THE DESIGN OF HIGHWAY BRIDGES AND THE CALCULATION OF STRESSES IN BRIDGE TRUSSES. By Milo S. Ketchum, C.E. New York: The Engineering News Publishing Company, 1908. 8vo.; 544 pp. Price, \$4.

The aim in writing this book has been to give a brief course in the calculation of the stresses in bridge trusses, followed by a systematic discussion of the details and the design of highway bridges. While there are many excellent books in which the different types of railway bridges are discussed in detail, little attention has heretofore been given to the design of highway bridges. As a consequence of this neglect, many of our highway bridges have been very badly designed, the design of these structures being ordinarily left to an engineer without experience or the agent of some bridge company who was more interested in the resulting profit than in obtaining a good design. The calculation of the stresses in highway and railway bridges is similar, but the problems in the design of the two types are very different, due to the different requirements and conditions. The problem of the design of a highway bridge includes the design of both the superstructure and the substructure. Most of the treatises on bridge design deal with the superstructure only, but in this book, due attention has been given to the design of both superstructure and substructure, and to the effect of the design of one on the other. The author discusses in detail the costs of the different parts of highway bridges. These costs are of value principally to the student and to the experienced engineer who is familiar with the conditions of the particular piece of work. The book is freely illustrated with drawings, diagrams, photo-engravings, and tables. It is an extremely valuable book for the engineer.

GENERAL LECTURES ON ELECTRICAL ENGINEERING. By Charles Proteus Steinmetz, A.M., Ph.D. Edited by Joseph Le Roy Hayden. Schenectady, N. Y.: Robson & Adee. 8vo.; pp. 284. Price, \$2.

The book contains a collection of seventeen lectures of a general nature, dealing with problems of generation, control, transmission, distribution, and utilization of electric energy. The work is largely descriptive and not mathematical. An appendix on light and illumination, and another on lightning and lightning protection, are also included in the volume.

SHOP TESTS ON ELECTRIC CAR EQUIPMENT. By Eugene C. Parham, M.E., and John C. Shedd, Ph.D. New York: McGraw Publishing Company, 12mo.; 55 illustrations; pp. 121. Price, \$1.

This is a small practical handbook adapted for the use of inspectors and foremen in the testing of electric car equipments. The tests are of such a character that they may be performed with the instruments and facilities available in a car house. In order to fix the rules and tests in the minds of the readers, many examples are given and a set of questions is provided at the end of the book.

MEMORIES OF MY LIFE. By Francis Galton, F.R.S. With eight illustrations. New York: E. P. Dutton & Co., 1909. Pp. 339. Octavo. Price, \$3.50.

Francis Galton is probably the hardest scientist to classify of our day, for the simple

reason that he was never a specialist for any great length of time, but has been what may be called a good "all-around" man of science. He has been an able statistician, a meteorologist, a "finger-print" classifier, a founder of anthropometrical and psychological laboratories, an explorer, a pedagogue, an authority on heredity, and the founder of "eugenics." These pleasantly written memoirs of his tell the story of his manifold activities in a simple, unaffected way, and give one many a rare glimpse of the great scientists who made the closing half of the nineteenth century one of the most remarkable periods in the history of the world. It is but natural that a man who has such strong notions on the subject of heredity should open his memoirs with a fairly exhaustive statement of his family stock.

Legal Notices

PATENTS

INVENTORS are invited to communicate with Munn & Co., 361 Broadway, New York, or 625 F Street, Washington, D. C., in regard to securing valid patent protection for their inventions. Trade-Marks and Copyrights registered. Design Patents and Foreign Patents secured. We undertake all Patent, Trade-Mark and Copyright Practice, both before the Patent Office and the Courts, and we have special facilities for handling Infringement and other suits in Federal and State jurisdictions. A Free Opinion as to the probable patentability of an invention will be readily given to any inventor furnishing us with a model or sketch and a brief description of the device in question. All communications are strictly confidential. Our Hand-Book on Patents will be sent free on request. Every patent secured through us receives special notice in the Scientific American. Ours is the Oldest agency for securing patents; it was established over sixty years ago. MUNN & CO., 361 Broadway, New York Branch Office, 625 F St., Washington, D. C.

INDEX OF INVENTIONS

For which Letters Patent of the United States were Issued for the Week Ending April 13, 1909, AND EACH BEARING THAT DATE [See note at end of list about copies of these patents.]

Table listing inventions with patent numbers and dates. Includes items like Abdominal support and truss, Abrasive apparatus, Acid, calcium salt of dibrom-behenic, Air compressor, etc.

Table listing inventions with patent numbers and dates. Includes items like Cap, miner's, W. C. Ballman, Cap, washable, S. Graff, Car construction, C. A. Lindstrom, etc.

AERMOTOR PUMPING DEVICES

Are known and used the world over. Hundreds of thousands of AERMOTORS in use. Thousands of GASOLINE PUMPS in use.

\$25 Buys an 8-ft. Aermotor. This is the galvanized-after-completion steel Aermotor which revolutionized the windmill business.

NOTE THE ROOM IN THE BASE OF THIS TOWER FOR PUMP, TANK OR STOCK.

\$27 Buys a 30-ft. Trussed Tripod Tower with unobstructed base.

The Aermotor Gasoline Pump is easily attached to "any old pump" in 30 minutes. The engine and pumping gears are assembled in one simple, compact and durable machine which is complete in every detail and ready to set up and go to work.

We make so many of these engines that we have put in the facilities for building them perfectly.

We are almost ashamed of so low a price on an engine so well designed and so well built, but we are proud of the engine.

No other pumping device ever gained such great popularity or reached such great sales in so short a time

PRICE \$37 1/2 For engine complete with walking-beam and supporting frame.



It occupies very little room, requires little attention, and gives a large amount of service. The supporting frame is clamped to the pump standard, making a very solid and compact arrangement.

You can afford to have one of these on every well.

These attachments have been devised to provide the easiest, quickest and most substantial way for connecting to any style of pump which is already in the well. Everything is supplied for setting up complete as shown, except the stakes.

AERMOTOR CO., Campbell Avenue and 12th Street, CHICAGO

- Engine gas generator, explosive, G. W. Price 918,197
Engine serial igniter, gas, H. A. Long 917,780
Engine sparker mechanism, H. M. Craner 918,286
Engine steering gear, traction, Randall & Whitcomb 918,368
Engle valve gear and governing mechanism, explosion, N. T. Harrington 917,941
Envelop, returnable, T. J. Sales 918,093
Envelop, safety, C. H. W. Koerner 918,330
Eyeglasses, H. S. Johnston 918,055
Eyeglasses, spring bow for, G. Bausch 917,837
Fabric shearing machine, woven pile, H. I. Mangoe 918,449
Fare register, R. C. Adams 917,834
Faucet, tap, valve, ball cock, etc., T. Crowe 918,288
Fire engine, gasoline, W. F. Gibbs 918,140
Fire escape, M. J. & G. A. Broome 918,275
Fire escape, R. Korb 918,333
Fire hose carrier, H. L. Jenkins 918,159
Firearm, L. L. Heppburn 918,447
Firearm with forward sliding barrel, automatic, A. W. Schwarzlose 918,380
Fish hook, L. Sheward 918,298
Fish hook coupling link, C. G. Davis 918,017
Fish stringer, L. B. Mullins 918,462
Fish trap, E. Jumiško 918,058
Flairton stand, W. L. Heady 918,148
Floor scraper, J. C. Peltier 917,890
Flour whitening and aging apparatus, H. Schuster 918,379
Fluid hoisting machinery, Blake & Aveling 917,992
Fluid pressure systems, automatic controlling mechanism for, W. J. Richards 917,897
Flushing apparatus, air chamber, R. Stick-dorn 918,216
Flushing tank, C. N. Marcellus 918,456
Fly paper holder, A. A. Frye 918,309
Folding stand, P. Plantinga 918,087
Foot rest, J. A. Gaertner 918,433
Friction brake, E. H. Ten Hoppen 917,909
Fruit, vegetable, and meat slicing machine, F. Hess 918,320
Fuel burner, liquid, W. E. Gard 918,310
Furnace, T. S. Blair, Jr., reissue 12,939
Furnace door frame and roof skewback, J. B. McKennan et al 918,356
Furnace stock distribution, blast, K. L. Landgrebe 918,172
Furniture, knockdown, P. Morrison 918,352
Furniture supporting foot, R. Clark 918,009
Furniture together, means for securing parts of, P. Sicotte 918,209
Fuse, electrical, W. H. Tidmarsh 918,223
Gaging device locking mechanism, G. O. Hammer 917,759
Game and recreation apparatus, race, A. G. Macculloch 918,343
Garment clasp, Coffey & Blayney 918,010
Garment fastener, E. Johnson 918,160
Garment hook, H. Poppert 918,088
Garment supporter clasp, S. Kops 918,168
Garment waistband adjuster, E. Holdgate 918,324
Gas and oxygen burner, H. Riess 918,089
Gas burner, F. E. Buddington 917,998
Gas burner, W. Wuthenow 918,245
Gas burner, inverted, J. Lederer 917,774
Gases, apparatus for the production of flame extinguishing, R. Scheuffgen 918,201
Gases, purifying, smelter, P. Danckwardt 918,424
Gate, J. J. Plowman 918,363
Gate for bins and other similar receptacles, A. E. Brown 917,746
Gate locking device, head, C. D. Butchart 918,002
Gearing, automatic change speed, L. Badois 918,258
Glass, beveling, Goehring & Troche 917,937
Glass sheets, method of and apparatus for making, H. K. Hitchcock 918,323
Gloves, G. W. Macdill 917,783
Go-cart, V. F. Pickert 918,962
Go-cart or baby carriage, A. J. Adams 918,250
Gold separator, L. L. Swenson 917,906
Grain cleaning machine attachment, C. H. Scott 918,095
Grain hulling mill, D. Uhlhorn, Jr. 918,226
Gramophone, H. F. Peltier 917,790
Granite molding and surface cutting machine, W. Murphy 918,187
Grate, C. W. Harvey 918,317
Grinder feeder, R. J. Steen 918,215
Grip mechanism, intermittent, C. Johnson 918,451
Hammer, B. F. Bird 917,840
Hammer, bed, G. F. Hoffman 917,866
Hanging clasp, J. M. Lamadrid 918,337
Harness connector, Jacky & Rupp 917,949
Harvester, corn, A. E. Combs 917,846

THE BEST RESULTS in light manufacturing, tool room, experimental laboratory, school and repair work... STAR LATHES... THE SENECA FALLS MFG. CO. 695 Water St., Seneca Falls, N. Y.

Engine and Foot Lathes MACHINE SHOP OUTFITS. TOOLS AND SUPPLIES. BEST MATERIALS. BEST WORKMANSHIP. CATALOGUE FREE SEBASTIAN LATHE CO., 120 Culvert St., Cincinnati, O.

Veeder Counters Price \$1.00 to register reciprocating movements of revolutions... VEEDER MFG. CO., 18 Sargeant St., Hartford, Conn. Cyclometers, Odometers, Tachometers, Counters and Fine Countings.

THE "BARNES" Upright Drills Positive Feed 10 to 50-inch Swing Send for Drill Catalogue. W. F. & JNO. BARNES CO. (Established 1872) 1999 Ruby St., Rockford, Ill.

\$54.00 per day The Record CAMERA-SCOPE And we can prove it. Any one can operate it. Makes 6 finished button photographs a minute. W. S. MOUNTFORD, 100 Maiden Lane, New York, N. Y.

WELL DRILLING MACHINES Over 70 sizes and styles, for drilling either deep or shallow wells in any kind of soil or rock. WILLIAMS BROS., Ithaca, N. Y.

A Home-Made 100-Mile Wireless Telegraph Set Read SCIENTIFIC AMERICAN SUPPLEMENT 1815 for a thorough, clear description, by A. Frederick Collins, of the construction of a 100-mile wireless telegraph outfit. MUNN & CO., 361 Broadway, New York

- Hasp for suit cases, W. E. Dooley 917,854
Hasp lock, A. L. Buckland 917,843
Hay carrier, P. A. Myers 918,077
Hay loader, wind shield, H. W. Betzby 918,267
Headlight, T. L. Hicks 918,151
Headstones from plastic material, apparatus for forming, C. C. Wingo 918,241
Heating plant, hot air, R. G. Elliott 917,756
Heating system, hot water, H. K. & I. Z. Kriebel 917,952
Hinge, H. Ernst 918,135
Hinge, door or window, J. Jordan 917,768
Hinge, watchcase, L. S. Hanson 918,043
Hoe, M. O. Whitehorn 917,980
Hoisting apparatus, H. C. Anderson 917,919
Hollow article mold, Kerr & Smith 918,328
Hoof pad, W. Heathermon 918,149
Horse detacher, J. W. Hughes 917,766
Horseshoe, A. Schlegel 918,094
Horseshoe hoof pad, T. F. Flaberty 918,032
Hose supporter clasp, R. B. Tunnicliffe 918,398
Hydraulic jack, Kohl & Joyce 918,167
Ice creeper, J. Kinsel 917,877
Ink ribbon feeding mechanism, automatically reversible, E. W. Scott 917,803
Instep supporter, A. Toporzer 918,101
Insulating support for high tension conductors, R. D. Mersbon 917,785
Insulator, W. G. Clark 918,127
Insurance policy, fractional, Catlett & Childress 918,280
Internal combustion engine, C. W. Snyder 918,211
Iron, metallurgy of, Simpson & Oviatt 918,381
Jack brace, wrench, W. B. Daugherty 917,928
Jar cover, T. I. Grove 918,315
Joint, H. E. Reeve 918,198
Letter bearing means, A. Lamson 918,359
Journal box dust guard, A. W. Neudeck 917,963
Keel, inverted, A. L. Reuss 917,896
Key, bath house, A. Pustera 917,894
Keyboard transmitter for Morse and other telegraphic codes, P. B. Delany 918,291
Knife, J. A. York 917,829
Knitting machine, circular, W. T. Barratt 917,989
Labeling machine wiper mechanism, F. O. Woodland 918,242
Lamp and burner, vapor, E. Charonne 918,005
Lamp, arc, W. G. Housekeeper 917,867
Lamp, calorimeter, H. Junkers 918,059
Lamp cluster, incandescent, Schwartz & Kleinmann 918,202
Lamp, gas, J. & G. Keith 917,876
Lamp, inverted hydrocarbon vapor, J. J. Meyer 918,071
Lamp, motor car and other, H. Cole 917,844
Lamp socket, incandescent, W. C. Tregoning 918,102
Lamp socket, incandescent, F. E. Seeley 918,477
Lamp starting means, G. M. Little 917,778
Lantern, Dickinson & Tyler 918,131
Lantern, C. K. Schade 918,476
Lantern construction, A. H. Handlan, Jr. 918,145
Last, J. H. Jones 918,162
Lathe, portable turning, W. D. Verschoyle 918,227
Laundry drier, wet wash, W. W. Anderson 918,114
Lawn edge trimmer, C. C. Wheeler 918,239
Leaf turner, D. Macdonald 917,782
Leafing machine, Fry, Riley & Hughes 917,966
Leather shrinking machine, A. Faifer 917,857
Letter and parcel holder, M. C. Long 918,340
Letter clamp, W. L. King 918,392
Lifting jack, W. H. Oliver 917,789
Lifting jack, W. R. Johnson 917,874
Light and power circuits, etc., automatic switch for, P. H. McCormack 918,489
Linoleum imitating wood, production of, T. Hollinger 918,153
Liquid level indicator, A. J. Stecker 918,098
Liquid meter, Speed & Wright 918,097
Lock, M. Nadolski 918,357
Lock for doors, coin controlled, H. F. Chreitberg 918,008
Locomotive, articulated, S. M. Vauclair 918,401
Locomotive engines and tenders, draft gear for, Westlake & Thomas 918,237
Loom for weaving cut pile fabrics, F. W. Rochelle 918,371
Loom shuttle, H. M. Brown 918,123
Loom shuttle box operating mechanism, G. M. Foster 918,430
Loom stop motion, D. Ward 917,817
Lubricating apparatus, F. T. Falcott 918,392
Lubricating means, H. S. Greene 918,312
Macaroni, drying, K. Gammel 918,436
Machine part having bearing sleeve, J. T. Uebbing 918,399

WE WILL MAKE your models and give you estimates on manufacture of any metal novelty. AUTOMATIC HOOK & EYE CO., Hoboken, N. J.

CONCRETE HOUSES Cost Less Than Wood Write for catalog and suggestions THE PETTYJOHN CO., 615 N. Sixth Street, Terre Haute, Ind.

"The Tool-Monger" Name given to a booklet of 288 pages which we shall be pleased to mail on request. Valueable to all users of Mechanics' Tools.

Montgomery & Co., 105-107 Fulton Street, New York City Your PATENTS and BUSINESS in ARIZONA. STODDARD INCORPORATING COMPANY, Box 8000 PHOENIX, ARIZONA

Gas, Gasoline and Oil Engines Including Producer Gas Plants By GARDNER D. HISCOX, M.E. THIS new revised and enlarged edition is a complete, comprehensive and thoroughly up-to-date work, treating fully on the construction, installation, operation and maintenance of gas, gasoline, kerosene and crude petroleum engines.



LAMBERT "30"—\$1250

A World Beater at the Price

THE 1909 automobile market offers no other "thirty" that compares with the Lambert "30" at the price. If you want a good car at about this price, it makes no difference how many other cars you may look at. If you see and drive the Lambert "30"—friction-driven, smooth-running, easy-riding, powerful on steep hills and muddy roads, speedy on good roads, graceful, well made—we will get your order.

Each of our six Lambert models, from the snappy \$800 runabout up to the big roomy 7-passenger Lambert at \$2000, is a car of full value—the choice of people who "find out" before they buy.

Write for fully illustrated descriptive catalog.

BUCKEYE MANUFACTURING CO.
1814 COLUMBUS AVE., ANDERSON, IND.

THE REASON WHY THE KREMENTZ

Roller Plate Collar Buttons Outwear all Others

THIS DIAGRAM ILLUSTRATES QUANTITY OF GOLD IN IMITATION BUTTONS

THIS ILLUSTRATES QUANTITY OF GOLD IN THE KREMENTZ BUTTON

At all dealers. Gold and rolled plate. Insist on the Krementz. If damaged in any way a new one free. Story of Collar Button showing shapes and sizes free. If dealer will not supply, we will.

Krementz & Co., 77 Chestnut St., Newark, N.J.

2¢ A WEEK

A safe, very brilliant, powerful, steady, white light. Is better than electricity or acetylene and cheaper than kerosene.

Every lamp is a complete self-contained miniature light works.

Clean—bright—odorless—portable. Made in over 200 styles for every purpose. Fully guaranteed. Catalog free. Agents wanted.

THE BEST LIGHT CO.
87 E. 5th Street
Canton, O.

THE "BEST" LIGHT.

ROTARY PUMPS AND ENGINES
Their Origin and Development.—An important series of papers giving a historical resume of the rotary pump and engine from 1588 and illustrated with clear drawings showing the construction of various forms of pumps and engines. 38 illustrations. Contained in SUPPLEMENTS 1109, 1110, 1111. Price 10 cents each. For sale by Munn & Co. and all newsdealers.

The Refined MOTOR

3 horse power and 6 horse power. Weight 60 and 110 pounds. All Refined Motors are guaranteed against defective material or poor workmanship during the life of the Motor and are also guaranteed the best Motor of their type in the world. Send for Catalog.

THRALL MOTOR CO.
47 East Fort St., Detroit, Mich., U.S.A.

ROYAL ENGINE

A simple, compact motor of strong, rigid construction, comprising the latest desirable features in gas engineering. 2½ to 15 horse power.

ROYAL EQUIPMENT CO.
145 Housatonic Ave., Bridgeport, Conn.

Free Catalogue of Scientific and Technical Books Free

We have just issued a new edition of our Catalogue of Scientific and Technical Books, which contains 144 pages, and a copy will be mailed free to any address on application.

MUNN & CO., Publishers of Scientific American
361 Broadway, New York

Mall bag catcher, J. M. Carver	917,922
Mall bag delivering and receiving apparatus, I. V. Fisher	918,136
Mall box fastening device, O. S. Smith	918,385
Manure cart, Schommer & Bosler	917,801
Manure spreader, Weber & Brown	918,232
Match receptacle, W. T. McDonald	918,079
Match safe, G. E. Parker	918,085
Measure indicating tag for fabrics, A. Van Kempen	917,913
Melon seeder, J. D. Whitsel	917,824
Melting furnace, J. E. Hewitt	918,150
Merchandise wrapper, N. J. Goodman	917,938
Metal bedsteads, detachable castor for, H. A. Palmer	918,081 to 918,083
Metal locker, R. W. Jefferis	917,869
Metal plates, machinery for upsetting the edges of, rolled, G. J. Hoskins	917,765
Metal strips edgewise, bending, G. S. Dunn	918,425
Metal tube machine, L. E. Hooker	918,154
Metal working machine, D. M. Watkins	918,105
Metals, producing, H. S. Blackmore	918,269
Metallic shelving, R. W. Jefferis	917,870
Metallic tie and rail fastener, S. J. Zaleski	917,831, 917,832
Meter. See Liquid meter.	
Milking machine, J. Nielsen	917,888
Milking machine, Sundberg & Hagg	917,905
Mixer, L. A. Thomas	918,394
Models, apparatus for making copies of, M. Kruse	918,171
Moisture producing and regulating device, L. M. Hartwick	917,863
Mold, Evert & Ryder	918,026
Mop or brush handle, W. W. Taylor	917,908
Mortar and concrete formations, solidifying, R. C. Stubbs	918,388
Music desk banger, piano, T. H. Lunde	918,066
Music sheets, apparatus for perforating master, H. M. Salyer	918,375
Musical instruments, duplex tracker bar for pneumatic, J. Wieser	917,825
Nail seal, K. Taylor	917,907
Nest, hen's, J. Hallar	917,862
Nozzle, suction, W. E. & J. H. Watson	917,819
Nut lock, P. P. Jargick	918,157, 918,158
Nut, etc., locking device, C. E. Rancillaz	918,367
Nut locking washer, A. C. Legere	917,776
Oil gate, Smith & McGregor	917,970
Ore separator, F. M. Mott	918,461
Oven, coke, J. Armstrong	917,744
Oyster carrier, R. C. Bender	918,264
Oyster receptacle, R. C. Bender	918,265
Packing box tie, E. P. Lehmann, reissue	12,941
Padlock, E. B. Stone	917,810
Pail or receptacle, C. Theurer	918,222
Pan lifter and lid holder, combination, A. R. Davis	917,929
Paper cutting machine, F. Bradmiller	918,120
Paper cutting machine, C. Seybold	918,205
Paper feed mechanism, Conger & Pearce	918,013
Paper filing device, P. H. Yawman	918,112
Paper rack, D. E. Price	918,196
Pawl and ratchet mechanism, J. C. Regan	917,965
Pelorus, Elliott & Ferber	918,133
Pencil holder, C. T. Carson	918,125
Pencil, lead, J. V. H. Nott	918,359
Perforating apparatus, H. M. Salyer	918,376
Phonograph attachment, H. E. Woods	918,111
Photographic film developing frame, E. B. Hansbury	917,940
Photographic holder and exhibitor, E. Halpern	918,040
Piano agraffe, L. Avisus, reissue	12,938
Piano bench, J. N. Wheeler	918,240
Piano, zither, J. A. Boebinger	917,994
Picture frame, J. B. Weber	918,233
Piles, making, G. A. Behrd	918,263
Pillow, C. Taarud	918,391
Pipe clamp, J. H. Wiest	918,407
Pipe cleaning apparatus, J. W. Roche	918,091
Pipe coupling head, automatic, Ward & Davidson	918,230
Pipe hanger, D. A. Donovan	918,021
Pipe joint, flexible, W. A. Greenlaw	918,144, 918,443
Pistol, automatic, W. J. Whiting	918,406
Pitman connection, C. E. Townley	918,225
Plane, bench, W. H. J. Vander Toorn	917,915
Planter, S. R. Hammit	918,041
Planter and fertilizer distributor, combined, J. W. Patty	918,364
Plastic bodies, automatic machine for forming, L. L. Burton	917,748
Plate, butter, Morris	917,962
Plow attachment, N. C. Y. Gundholm	918,445
Plow fender, corn, E. F. Kolosick	918,332
Plow gang, A. Mecham	918,182
Plow, motor, A. E. Cook	918,128
Potato cutter, E. Q. Couch	917,849
Power transmission apparatus, R. J. Fry	918,034
Power transmission mechanism, Seddon & Douglas	917,968
Printing and developing photographs on silver chlorid paper, H. J. Mallabar	918,347
Printing apparatus, G. W. Merrill	917,734
Printing device, W. L. McCarty	918,464
Printing machine, W. L. Green	917,861
Printing press, W. L. McCarty	918,465
Printing press attachment, A. Fields	918,428
Printing press, flat bed, H. F. Bechman	917,838
Printing shop counter check books, etc., machine for, F. Waite	918,104
Propeller float, P. Ferrari	918,029
Protractor or spacing instrument, E. M. Low	918,065
Pulley, band, C. Wyszong	918,248
Pulp screen plate fastener, E. A. Bayley	918,261
Pulverized substance, distributor for, S. W. & W. H. Farnham	917,757
Pump, T. E. Cherry	918,007
Pump, G. L. Herz	918,319
Pump, hydraulic rotary, I. H. Spencer	917,971
Pump, oil well, F. Morgenstern	918,460
Pump, valve, J. E. Hill	918,448
Punch, electromagnetic, J. J. Leidigh	917,955
Rack. See Display rack.	
Rack and car, combination, J. S. Wintermute	918,109
Rail bond terminals, mold for casting, W. H. Wherry	918,108
Rail joint, G. H. Pickering	918,467
Rail stay and brace, combined, J. M. Vail	917,815
Rail tie, P. Donovan	918,022
Rail tie and fastener, T. Johnson	918,452
Railway crossing gate, P. Hamer	917,939
Railway electric signaling system, J. S. Holliday	917,763
Railway portable coach, E. Bengtson	918,266
Railway signaling system, M. W. Zahor	917,830
Railway tie and rail fastening, W. P. Day	917,932
Railway tie, metallic, M. M. Riley	917,797
Railway tie, metal, W. H. Wood	918,110
Railway track, C. J. Burbank	918,277
Railway track crossing, metal, J. Anderson	918,113
Railway track structure, H. R. Lutber	917,957
Range and cooker, combined gas, H. B. Cornish	917,848
Range finder, depression, D. von Nagy	918,190, 918,191
Range, gas, A. C. Arthur	918,253
Razor, safety, O. A. Clark	918,123
Receptacle, R. & W. Wesener	918,405
Recording instrument, W. H. Bristol	918,274
Relay, polarized, P. Ribbe	918,199
Resilient wheel, G. M. Eaton	917,855
Rice huller, D. J. Hayes	918,048
Rivet, Farnell & Barron	918,305
Riveter, portable hand, P. S. Moe	918,351
Road bed, G. W. R. Culbertson	918,289
Road construction and making same, F. S. Hutchinson	918,156
Road grader, S. A. Ulrich	917,977
Rod safety appliance, connecting, E. D. Church	917,924
Rotary engine, Quigley & Meyer	917,792
Rotary engine, B. F. Hoffman	917,944
Rubber shoes, apparatus for varnishing, J. H. Wall	918,228
Rubber stamp, self-inking, L. P. Lowe	917,781
Rolling machine, T. Munzert	918,076
Sack holder, R. H. West	917,820
Safety device, D. M. Watkins	918,106
Salt and pepper box, H. A. Sedgwick	917,804
Sample case, merchandise, C. G. Duffy	918,297
Sand, etc., disposing of tailing, J. F. Jackson	918,054
Sash fastener, W. C. Robinson	918,090
Sash holder, T. H. Wilson	917,827
Sash, swinging sliding window, L. Boffrd	918,270
Sash, window, F. C. Borgmeyer	918,271
Saw handle, J. P. Jensen	917,871
Saw vise, J. Ljung	918,338

The New Models 10 and 11 of the Remington Typewriter

are the ripest fruit of Remington experience, the highest achievement of Remington skill and the perfect evidence of Remington leadership.

Some of the New Features:

- New Single Dog Escapement
- New Column Selector (Model 10)
- New Built-in Decimal Tabulator (Model 11)
- New Two-Color Dial
- New Back-Space Key
- New Variable Line Spacing Lock
- New Shift Lock
- New Paper Feed

Remington Typewriter Company
(Incorporated)
New York and Everywhere

Roberts' Motors Are Trouble Proof

They are designed by E. W. Roberts, M.E., one of the most expert mechanical engineers in the U. S., and constructed under his personal supervision, 1½ to 60 H. P., and every one guaranteed. No "freak" ideas—no gaskets—economical in use of fuel—interchangeable parts that fit perfectly—remarkable flexibility of control—simple in construction—no base explosions—or "back fire," and tested in the BEST TESTING ROOM in the U. S.

WRITE FOR OUR CATALOGUE and Book of Testimonials

ROBERTS MOTOR CO., 1411 Columbus Ave., Sandusky, Ohio, U. S. A.

Engineering News

(ILLUSTRATED)

The Leading Engineering Paper of the World. For Civil, Mechanical, Mining and Electrical Engineers 100 to 125 pages, 9" x 13", weekly. Send ten cents for sample copy.

If you cannot locate desired engineering equipment write our "Readers Want" department.

THE ENGINEERING NEWS PUBLISHING CO. 214 Broadway, New York

READY MAY 1st

The Design and Construction of Induction Coils.

By A. FREDERICK COLLINS

We take pleasure in announcing that our new book on "Induction Coils," by A. Frederick Collins, is now nearly ready, and will be published about May 1st

THIS work gives in minute details full practical directions for making eight different sizes of coils, varying from a small one giving a ½-inch spark to a large one giving 12-inch sparks. The dimensions of each and every part down to the smallest screw are given and the descriptions are written in language easily comprehended.

Much of the matter in this book has never before been published, as, for instance, the vacuum, drying and impregnating processes, the making of adjustable mica condensers, the construction of interlocking reversing switches, the set of complete wiring diagrams, the cost and purchase of materials, etc. It also contains a large number of valuable tables, many of which have never before been published.

It is the most complete and authoritative work on the subject, and contains 295 pages and 155 illustrations from original drawings made specially for this book. The price is \$3.00 postpaid.

Send us your order at once and a copy of the book will be mailed to you just as soon as published.

MUNN & COMPANY, Publishers, 361 Broadway, New York

Puts a Razor in A-1 Condition

The secret of easy shaving lies in the quality of your strop. There's no "knack" in having a sharp razor if your strop is a "Torrey." A few strokes on a

TORREY STROP

puts a razor in the finest possible trim for a cool and easy shave. Ask your dealer for Torrey Stropps and Razors

Torrey Stropps are sold for 50c, 75c, \$1.00, \$1.50, \$2.00 and \$2.50. Sent postpaid if not at dealer's. Torrey's Oil-Edge Dressing keeps a strop soft and pliable. Write for free catalogue containing valuable information for men who shave. J. R. TORREY & CO., Dept. G Worcester, Mass.



ALLEN'S FOOT-EASE

Shake Into Your Shoes



Allen's Foot-Ease, a powder for the feet. It relieves painful, swollen, smarting, nervous feet, and instantly takes the sting out of corns and bunions. It's the greatest comfort discovery of the age. Allen's Foot-Ease makes tight-fitting or new shoes feel easy. It is a certain cure for ingrowing nails, sweating, callous and hot, tired, aching feet. We have over 30,000 testimonials. **TRY IT TO-DAY.** Sold by all Druggists and Shoe Stores, 25c. Do not accept any substitute. Sent by mail for 25c. in stamps

FREE TRIAL PACKAGE sent by mail. **MOTHER GRAY'S SWEET POWDER**, the best medicine for Feverish, sickly Children. Sold by Druggists everywhere. Trial Package FREE. Address, ALLEN S. OLMSTED, Le Roy, N. Y.

The Strelinger

4 CYCLE 16 CYLINDER

For over 12 years the name "Strelinger" has stood as the best in marine gasoline engines. A distinct success. First quality from flywheel to propeller. Strong, sturdy, RELIABLE, speedy, troubleless. The engine that **ALWAYS Makes Good** Because Built Right. Famous for endurance, fuel economy, power, steady, smoothly, quietly, vibration. From 4 to 100 H.P. Free Catalog lists engines \$35 up to \$2,500. Write for a copy. Enclose 10c. stamps for nickel-plated pocket marine compass.



STRELINGER MARINE ENGINE CO. 56 Congress East, Detroit, Mich.

There is no need of paying more money for a woodworking machine than the price of a **CRESCENT**



GILSON GASOLINE ENGINE For Pumping, Cream Separators, Churns, Wash Machines, etc. FREE TRIAL. Ask for catalog—all sizes. **GILSON MFG. CO.** 309 Park St. Fort Washington, Wis.

SPARK COILS

Their Construction Simply Explained
Scientific American Supplement 160 describes the making of a 1 1/2-inch spark coil and condenser.
Scientific American Supplement 1514 tells you how to make a coil for gas-engine ignition.
Scientific American Supplement 1522 explains fully the construction of a jump-spark coil and condenser for gas-engine ignition.
Scientific American Supplement 1124 describes the construction of a 6-inch spark coil.
Scientific American Supplement 1087 gives a full account of the making of an alternating current coil giving a 5-inch spark.
Scientific American Supplement 1527 describes a 4-inch spark coil and condenser.
Scientific American Supplement 1402 gives data for the construction of coils of a definite length of spark.
The above-mentioned set of seven papers will be supplied for 70 cents.
Any single copy will be mailed for 10 cts. **MUNN & COMPANY, Publishers** 561 Broadway New York

Sawmill appliance, J. R. Hodgen 918,152
Scale ticket, F. C. Maegly 918,346
Scaling device, W. M. Shaw 917,805
Score board, M. J. Shimer 918,207
Screw driver, C. E. Mitchell 918,073
Seat for saddle implements, adjustable, C. & E. G. Young 918,249
Seat rail attachment, adjustable, C. R. Allen 918,251
Selective controller, R. Symmonds, Jr. 917,973
Sewer cleaning apparatus, W. A. Pierce 917,892
Sewing machine, J. E. Miller 918,184
Sewing machine seat, Elben & Giarusso 918,024
Shade, window, E. W. Webb 918,404
Shaft collar, J. McCaffrey 918,078
Shaft coupling, F. Bockemeyer 917,842
Shaft coupling, extensible, R. S. King 918,062
Sheaf carrier, W. Martindale 918,457
Sheet delivery mechanism, G. E. Pancoast 918,084
Sheet metal can opener, B. E. Morse 918,074
Sheet steel keg for white lead, C. Stollberg 918,387
Shelf or case, A. Grundmann 918,039
Shingling appliance, F. P. Dillon 917,853
Shock absorbing device, C. H. Foster 918,429
Shoe for tie bands, steel forged, H. Drum 918,296
Shoe sewing gaging mechanism, A. E. Jeram 917,872
Shoe shank support, A. E. Block 917,941
Shutter attachment, C. Maechler 918,345
Shutter fire resisting, L. G. Wilson 917,983
Sign, F. P. Barrett 917,888
Signal light apparatus, G. Dafen, reissue 12,940
Signal system, J. R. Walsh 918,229
Signaling and train stopping device, automatic, H. Davis 918,018
Signaling apparatus, wireless, R. A. Fessenden 918,307
Signaling, wireless, R. A. Fessenden 918,306
Sink, F. H. Caldwell 918,124
Sink or shelf bracket, B. A. Berger 918,415
Skate roller, W. J. Hille 918,321
Skylight ventilator, W. J. Smreka 918,210
Sled, hob, N. S. Doolittle 917,755
Sleeve, self-oiling, H. A. Davis 917,931
Sleigh knee, P. Gossline 918,441
Sleigh propelling mechanism, J. D. Frye 918,431
Snap fastener, G. A. Holmes 918,325
Soaps containing peroxides, manufacture of, R. F. Wolfenstein 917,828
Solar attachment, G. N. Saegmuller 917,799
Sound reproducing apparatus, W. O. C. Ellis 918,303, 918,304
Spark arrestor, Dan C. Hockenjos 918,290
Spinning frame, ring, H. C. Hockenjos 917,865
Spool holder, F. Mayor 918,180
Spring. See Vehicle spring.
Spring, coil, J. B. Knudsen 917,770
Spring, furniture, J. L. Rademacher 917,793
Spring uncoiling machine, H. W. Brashear 918,121
Spring wheel, J. J. Collins 917,845
Spring wheel, K. F. Elers 917,856
Sprinkler and hose reel, lawn, C. Buebler 917,999
Sprinkler emergency stopper, automatic, J. P. Casey 917,923
Square, tailor's, J. A. Carlstrom 918,279
Stamp, time, F. Purdy 917,893
Starching machine, W. C. Straszer 918,481
Station indicator, J. G. Harris 918,044
Steam boiler, P. Barnes 918,260
Steam separator, P. A. Johnson 918,326
Steam separator and heater, G. R. Sister-son 918,479
Steam trap, N. English 918,134
Steel, metallurgy of, Simpson & Oviatt 918,382
Steel pling, G. G. Krivoshe 918,064
Steering device, C. E. Brooks 918,122
Sterilizer, Wiley & Hall 918,409
Stick pin and pencil, combined, F. A. Rojas 918,475
Stirrup, safety, J. Solatnow 918,212
Stitch machine, impression or imitation, A. C. Spencer 917,807
Stock marker, C. F. Moffitt 917,961
Stoker, mechanical, J. A. Caldwell 917,750
Stoker, mechanical, W. H. Strouse 918,217
Stove, E. B. Hammond 918,042
Stove, air-tight heating, L. W. Hemery 918,313
Stud, self-centering fixture, J. L. Corey 917,847
Surveying instrument, G. N. Saegmuller 917,800
Sweat band, E. M. Johnson 917,873
Swingletree clip, S. Rogers 917,899
Switch, G. W. Hart 917,760
Switch, L. H. Moulthrop 918,353
Switch, Gaglio & Villani 918,434
Syringe, C. F. Welsh 918,234
Tack puller, J. S. Swan, Jr. 918,219
Talking machine needle, J. E. & W. B. Sullivan 918,389
Talking machine needle holder, W. B. Clafin 917,925
Taps in receptacles for holding liquids, securing, E. O. Blackwell 918,117
Target, drop, J. Kreek 918,170
Target throwing trap, E. D. Fulford 918,432
Target trap, J. A. Crenshaw 917,850
Teat cups, pulsating, A. Gillies 918,438
Telegraph system, G. E. Hines 918,322
Telegraphy, P. B. Delany 918,293
Telegraphy, antenna for wireless, H. E. Atherton 918,255
Telescope, prism, C. S. Hastings 918,147
Templet for infolding machines for collars, cuffs, etc., G. J. Dormandy 918,023
Tenter frame, D. J. Tavener 918,220
Testing machine, A. H. Emery 918,488
Thermometer case, M. W. Reed 918,472
Thresher yielding concave, C. W. Clark 918,285
Threshing machine attachment, C. O. Fredrickson 918,139
Tide motor, W. J. White 917,823
Tie tamper, F. J. Gilroy 917,860
Time recorder, workman's, C. T. Hawley 917,761
Time relay for selective signaling, H. A. Watson 917,916
Tire, pneumatic, B. Noldner 917,889
Tire sealing composition, vehicle, W. W. McCord, et al. 918,189
Tire sbeathing, J. Marti 918,350
Tires and tubes, making rubber, F. A. Magowan 917,958
Tires, machine for bevelling air tubes for pneumatic, A. Oller 918,360
Tobacco leaves, machine for threading, W. T. Muggil 918,075
Toilet article, G. M. Irwin 918,053
Tongue bounds, P. A. Gehring 918,035
Tool, I. E. Stump 918,483
Tool, centering, S. Sauer 918,378
Tooth, artificial, T. McCullough 917,886
Tooth brush case, P. A. Rohr 918,372
Tooth cleaning device, E. C. Chambers 918,281
Tooth, camper's, J. F. Menge 918,006
Torch, vapor, W. Chausse 918,444
Toy gun, B. Griffith 918,028
Train indicator, P. Ferrari 917,794
Transformer system, K. C. Randall 918,208
Transmitting apparatus, H. Shoemaker 918,377
Trolley guard, G. W. Sandiford 917,985
Truck, baggage, Allen & Reed 918,061
Truck, railway, H. H. Vaughan 917,979
Trunk, etc., catch lock, D. W. Eggleston 918,300
Trunk tray form, W. S. Gilson 918,311
Tubes, apparatus for producing corrugated, Pogany & Lahmann 918,469
Tumbler washer, J. S. Nash 917,887
Tunneling machine, E. F. Terry 917,974
Twister stop motion and measuring mechanism, A. E. Rhoades 918,473
Typing machine, mantle, S. Cohn 918,011
Type casting machine, J. S. Thompson 917,975
Typewriter, C. C. Christman 918,283
Typewriter machine, W. J. Barron 917,745
Typewriter machine, B. C. Stickney 917,809
Typewriter machine, R. E. Martin 917,959
Typewriter machine, F. X. Wagner 918,103
Typewriter machine, O. Woodward 918,243
Typewriter machine, J. F. Forkarth 918,308
Typewriter machine, F. L. Morgan 918,459
Typewriter machine, G. H. Smith 918,480
Umbrella, J. P. Czaplowski 918,015
Valve, F. T. Reid 917,895
Valve, D. T. Williams 917,981
Valve, J. R. Goehring 918,143
Valve, L. W. Eggleston 918,301
Valve, automatic retaining, Martin & Beasley 918,179
Valve cover ring, Blanchard & Darling 917,920
Valve, float, J. S. Brennan 918,272
Valve, float, G. J. Griffin 918,314
Valve for hot water heating systems, H. G. Thomas 917,813
Valve governor, triple, C. H. Hughes 917,946

Keeps Contents Hot a Day and a Night

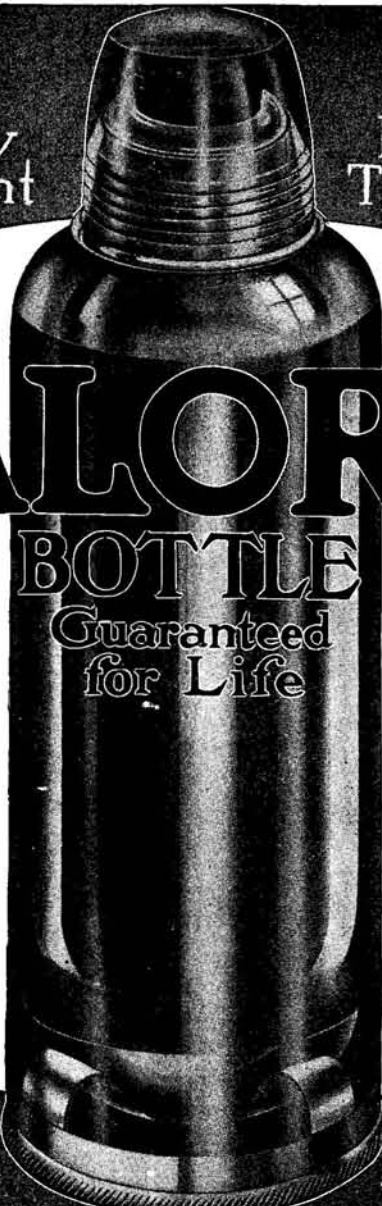

Keeps Contents Ice Cold Three Days

CALORIS BOTTLE

Guaranteed for Life
Buy a Vacuum Bottle as you would a watch—not by the outside of the case—but the inside works. Exercise this same caution, and you will unhesitatingly choose the CALORIS. The CALORIS BOTTLE will stand much harder usage than any other Vacuum Bottle. The fact that we give you a lifetime guarantee while other makers limit their confidence to 60 days, tells you which bottle to buy. Note patented construction in shadowgraph picture. "Indestructible" CALORIS—mounted nickel case with gold lined cup—removable glass bottle.

Pint Size \$3.50
Quart Size \$5.50

CALORIS MFG. CO.
New York Office
503 5TH Ave.

16 FOOT STEEL LAUNCH \$96

With 2 H.P. Engine Complete

18-21-25 foot launches at proportionate prices. All launches fitted with two cycle reversing engine with speed controlling lever; simplest engine made; starts without cranking, has only 3 moving parts. Steel row-boats, \$20.00. All boats fitted with water-tight compartments; cannot sink, need no boat house. We are the largest manufacturers of pleasure boats in the world. Orders filled the day they are received. We sell direct to user, cutting out all middle-men's profit. Free Catalogue.

Michigan Steel Boat Co., 1382 Jefferson Ave., Detroit, Mich.

THE MOTORCYCLE

has "arrived." It is perfectly practicable for any man capable of riding a bicycle and will carry a single passenger as fast and as far as an automobile.

The Greyhound

is as good as the best in material, workmanship and reliability, and is absolutely the simplest and most comfortable motorcycle in the world. Correspond with us about any motorcycle matter that interests you, either as rider or dealer. Catalogue free.

THE AUTO-BI CO., 1450 Niagara St., Buffalo, N. Y.
Oldest American Motorcycle Makers

The Man Who Pays For the Motor

Should get Good Material and Workmanship. Cushman Marine Engines have ground cylinders, pistons, piston rings, crank shafts, crank and piston pins hardened. The only 2-cycle engine with adjustable gas tight bearings. All parts are interchangeable. Get a catalogue if interested in engines from 2 to 15 H. P.

CUSHMAN MOTOR CO.
2026 N Street, Lincoln, Neb.

METAL POLISHES.—FORMULAS FOR Putz Pomades, Pastes, Liquids, Powders and Soaps for polishing metals, are contained in **SCIENTIFIC AMERICAN SUPPLEMENT** Nos. 1283, 1288 and 1289. Price 10 cents each from this office and all newsdealers.

"POROX"

Storage Batteries

The best for ignition and light. No loss of current. Absolutely reliable. Transparent jars are used for all batteries. 6 volt. 60 ampere hour battery. Price \$27.00.

Send for catalogue
ALBERT MÜLLER
145 West 49th Street, New York

Musical Tubular Bells

Highest Mechanical and Musical Art
Have you a taste for MUSIC? No talent required. Not only increases social standing, but some people have had their salary increased five fold by using our Musical Novelties. Can be learned in hours where ordinary instruments takes months. Send for our new 100-page illustrated catalogue free. Also 24 pages standard and popular sheet music arranged for one or two people, showing how to play our instruments, for 24 cents in stamps.

J. C. DEAGAN
2157 No. Clark St., Chicago, Ill.

\$3.50 A Backus Water Motor

Water Motor

For Polishing, Grinding, and Power
Can be screwed on any faucet

BACKUS WATER MOTOR CO. Newark, N. J.

BE TIME-WISE

Keep Things Moving. Stamp time, date, etc., indisputably on orders, telegrams, letters, cost, time and delivery tickets, etc., with the Automatic Time Stamp. Durable. No rubber or soft stuff. Accurate, reliable. Write for booklet. Agents Wanted.

AUTOMATIC TIME STAMP CO.
161 Congress St., Boston, Mass., Est. 1880
Originators of the art of printing time

How to Build a 5 H.P. Gas Engine at Home

In **SCIENTIFIC AMERICAN SUPPLEMENTS** 1641 and 1642, E. F. Lake describes simply and thoroughly how a five horse power gas engine can be built at home. Complete working drawings are published, with exact dimensions of each part. Price by mail for the two Supplements, 20cents.

Order from your newsdealer or from

MUNN & COMPANY
Publishers
361 Broadway, New York

Classified Advertisements

Advertising in this column is 75 cents a line. No less than four nor more than ten lines accepted. Count seven words to the line. All orders must be accompanied by a remittance. Further information sent on request.

READ THIS COLUMN CAREFULLY.—You will find inquiries for certain classes of articles numbered in consecutive order. If you manufacture these goods write us at once and we will send you the name and address of the party desiring the information. There is no charge for this service. In every case it is necessary to give the number of the inquiry. Where manufacturers do not respond promptly the inquiry may be repeated.

MUNN & CO.

BUSINESS OPPORTUNITIES.

WANTED.—Quick selling specialties for agents. We have one of the largest selling organizations in the world but need new, salable goods. Manufacturers having such an article, but lacking organization to push it properly, should write us immediately. Established over 25 years. Our salesmen cover U. S., Canada and several European countries. Exclusive rights only considered. The Scarborough Company, Indianapolis, Ind.

Inquiry No. 8868.—Wanted to buy nickeloid for buttons.

A RESPONSIBLE PROFESSIONAL MAN and laboratory worker invites attention to a new artificial material, analogous to celluloid, zylonite and the like, and which would seem to be adapted to a variety of industrial uses. Samples, both finished and unfinished, will be submitted to interested persons. Correspondence is invited. Address Box 235, Higganum, Conn.

Inquiry No. 8877.—For manufacturers of convex glass for pictures.

MY BOOK, "Building a Business," tells how mail order agency business can be started with capital of \$50 to \$100, and make several thousand dollars annually. It's free. Robert Hicks, St. Louis, Mo.

Inquiry No. 8885.—For manufacturers of the "Mysterious Ball" like that of Mr. Lepere's—a man in a ball.

PARTNER WANTED.—Will give any State in union, one-half profits of others, for placing Car Brake No. 9935 on the market. For further information address J. G. Kerr, Ionia, Kans.

Inquiry No. 8889.—Wanted to buy a machine which breaks and divides apricot stones.

CAPITAL OR MANUFACTURER DESIRED.—Patented window frame, etc., for movable shade roller. Royalty and lump sum. Address G. K., Box 773, N. Y.

Inquiry No. 8894.—For manufacturers of an automatic camera for making photographs on pin trays, etc.

HALLAS.—Oey Tjauw Bi in Bandoeng, Java, desires to become agent for manuf. of auto cars and wagons.

Inquiry No. 8897.—For the manufacturers of the "Lid on" can opener.

PATENTS BOUGHT, sold, capital interested, articles desired for mail, agents, salesmen wanted everywhere. Manufacturers & Inventors Sales Co., Binghamton, N. Y.

PATENTS FOR SALE.

FOR SALE.—U. S. Patent No. 915,489. Canadian Patent No. 116,225, moulding flask and jacket. Non-collapse and expandable, of great merit, cheap and durable. Schrag & Murray, 72 Macdonell Ave., Toronto, Canada.

Inquiry No. 8904.—Wanted to buy new or second hand machinery for making "bow type" mouse and rat trap springs and wire parts, single machine or full outfit.

FOR SALE.—Patent No. 904,273. Bullet mould. Practical and effective. Its interchangeability will make it a pleasure to load bullets, for every pistol or rifleman. Sell reasonable. A. J. Mundt, Ontonagon, Mich.

Inquiry No. 8908.—For a dealer in tapes and cords for Venetian blinds.

FOR SALE.—Patent No. 68,450. "Den'Dron." Nature's remedy used both internally as well as externally. For further particulars address E. Wiyick, 1090 Tremont Street, Roxbury, Mass.

Inquiry No. 8909.—For a machine to paint shade or blind rollers.

FOR SALE.—Patent No. 484,703. An improved pool and billiard cue tip, but tapered dove-tailed style. Needs no repairs. Simply insert new tip when old one wears out. Manufacturers and players get the tip that wins the game. Ask for sample. For further particulars and full information address William M. Dunn, Box 214, Atlanta, Ind.

Inquiry No. 8918.—For manufacturers of "Wyd's Electro-Catalytic Sparking Plug."

FOR SALE.—French, Austrian, Belgian and Spanish patents on useful device which has large sale to banks and public in America. For further particulars address "Device," Box 773, New York.

Inquiry No. 8921.—For the manufacturers of gilt paper

FOR SALE.—Patent 770,716. Most scientific finger-gramp preventer, easy writer and finger-rest penholder. Write with it all day, and your hand never tires. Address J. Engel, 711 Eighth St., Milwaukee.

Inquiry No. 8922.—Wanted the address of Worthington Boiler Co.

THE PATENT RIGHTS IN U. S. of "Locke's Wire Strainer" for \$1,200, cash sale. Offers from bona fide manufacturers to make on royalty will be considered by Duncombe, Hobart, Tasmania.

WANTED at once offers from reliable firms in Canada to manufacture in Canada Locke's Patent Wire Strainer, No. 125759, to preserve patent rights in that country. Duncombe, Hobart, Tasmania.

Inquiry No. 8928.—For the manufacturers of a steam rotary excavator as described in the Scientific American of December 12, 1908, page 847.

HELP WANTED.

LOCAL REPRESENTATIVE WANTED.—Splendid income assured right man to act as our representative after learning our business thoroughly by mail. Former experience unnecessary. All we require is honesty, ability, ambition, and willingness to learn a lucrative business. No soliciting or traveling. This is an exceptional opportunity for a man in your section to get into a big paying business without capital and become independent for life. Write at once for full particulars. Address E. R. Marden, Pres., The National Co-operative Real Estate Company, Suite 378, Marden Building, Washington, D. C.

Inquiry No. 8931.—For parties who manufacture the Western Stump Borer for boring stumps.

WANTED, by large machinery manufacturing concern, chief inspector. Must be first-class mechanic, experienced on gasoline motor work, capable of organizing and directing corps of inspectors. Good permanent position to right man. Give references, experience and salary wanted. Address Chief Inspector, Box 773, N. Y.

LISTS OF MANUFACTURERS.

COMPLETE LISTS of manufacturers in all lines supplied at short notice at moderate rates. Small and special lists compiled to order at various prices. Estimates should be obtained in advance. Address Munn & Co., List Department, Box 773, New York.

Inquiry No. 8936.—Wanted machinery used to spin or wrap paper pencils in the manner that paper pencils are made.

UNITARIAN LITERATURE, including sermons and weekly publications, sent free, on application to Miss Peck, 106 George Street, Providence, R. I.

A LIST OF 1,500 mining and consulting engineers on cards. A very valuable list for regularizing, etc. Price \$15.00. Address Munn & Co., List Department, Box 773, New York.

MISCELLANEOUS.

"HOW TO SUCCEED AS AN INVENTOR." 100-page book written by an expert, sent for two stamps Address Goodwin B. Smith, No. 700 Stafford Building, Philadelphia, Pa.

Inquiry No. 8941.—For manufacturers of machinery for making fly screens.

Inquiry No. 8943.—Wanted a portable hand machine for breaking stones for installing road surface. To be worked by two or three men.

Inquiry No. 8944.—For the address of the manufacturers of the King or lever collar button.

Inquiry No. 8948.—For manufacturers of gearing, noiseless or otherwise, suitable for speed of 3,000 to 4,000. 4. p. m., for wheels 5 inches diameter.

Inquiry No. 8950.—For manufacturers of machinery for the production of Coquito, Palm, Babosa, and Mame seed or nuts.

Inquiry No. 8951.—For manufacturers of machinery for making milk bottle sanitary fiber caps.

Inquiry No. 8952.—For firms making apparatus for using oil for fuel under a steam boiler instead of coal.

Inquiry No. 8953.—For manufacturers of water turbines.

Inquiry No. 8954.—For machinery used in manufacturing collar buttons.

Inquiry No. 8955.—For a machine to extract the small kernel from the pea-nut.

Inquiry No. 8956.—For makers of wood distilling machinery, also makers of philosophical instruments and chemists' hardware.

Inquiry No. 8957.—Wanted manufacturers of angle bars either malleable steel or sheared.

Inquiry No. 8960.—For the address of the Windsor Mfg. Co., manufacturers of waterproof collars and cuffs.

Inquiry No. 8961.—For the manufacturers of imitation pearls.

Inquiry No. 8962.—For the manufacture of the different parts of vacuum systems such as electric motor and pumps.

Inquiry No. 8963.—Wanted a machine for wrapping coin.

Inquiry No. 8964.—For address of parties making imitation horse hair.

Inquiry No. 8965.—Wanted the address of the Dirt Mover Magazine.

Inquiry No. 8966.—Wanted the address of the Cohendet Motor Co.

Inquiry No. 8967.—Wanted to buy cheap grade of cotton by the bale.

Inquiry No. 8968.—Wanted to buy a machine for crushing and grinding tobacco stems to a powder.

Inquiry No. 8969.—Wanted machines that make accordion dress plating (steam).

Inquiry No. 8970.—For manufacturers of equipment for denatured alcohol.

Inquiry No. 8971.—For manufacturers of a metal placket fastener for women's skirts or a metal fastener for the front of men's trousers.

Inquiry No. 8972.—Wanted to buy complete outfit for making meat hooks.

Inquiry No. 8973.—Wanted to buy a gasoline engine with equipment ready to put on a hearse or other vehicle of like order, work to be done by any local mechanic.

Inquiry No. 8974.—For address of firms interested in fishing reels.

Inquiry No. 8975.—Wanted the address of the builders of moving stair cases.

Table listing various mechanical parts and their prices, including Valve grinding device, Valve regulator, Valve reseating machine, etc.

DESIGNS.

Table listing various designs and their prices, including Cabinet, sewing, H. R. Miller, Card, menu, M. Altman, etc.

POWER REQUISITES. Get the engine that runs reliably, requires least attention and is a dependable starter. The simple, powerful I. H. C. Gasoline Engines. Vertical, 2, 3 and 25-H. P. Horizontal (portable and stationary), 4, 6, 8, 10, 12, 15 and 20-H. P. Air Cooled, 1 and 2-H. P. Call on I. H. C. Agents or write for catalog. INTERNATIONAL HARVESTER CO. OF AMERICA (Incorporated) 15 Harvester Bldg., Chicago, U. S. A.

Send for our free Boat Book. Do not think of buying a launch until you see our Four Launch Bargains. Only \$121 for this complete 16 foot launch. 2 1/2 H.P. guaranteed, self-starting engine. \$144 for 9 1/2 mile per hour "Speedaway." \$153 for canopy topped "Winner." \$160 for Auto-topped 3 H. P. "Comfort." All 16 feet in length. Engine result of 30 years' experience. Weedless wheel and rudder. Shipped immediately. Money back if not as represented. Send postal for our hand some catalog today—it's a gem. C. T. WRIGHT ENGINE CO. 608 Washington Street, Greenville, Mich.

No Boats Like Mullins Boats. They are lighter, stronger and easier to row. Built of pressed steel, and fitted with large air chambers like life boats. They are absolutely safe—never leak—crack—dry out—warp—or sink—and last a lifetime. The ideal boat for families—hunting—fishing—summer resort—boat liversies, etc. Our catalog of row boats, hunting boats, fishing boats, launches, motor boats and marine engines tells you all about our 1909 Models and what exceptional values they offer at very reasonable prices. Better write for a copy today. W. H. Mullins Co., 118 Franklin Street, Salem, O.

What Collier's Controls and What Collier's Offers Advertisers

IN no other magazine during 1909 will be found the Drawings of Charles Dana Gibson, Maxfield Parrish, and Frederic Remington, the Sherlock Holmes Stories of Conan Doyle, the Poems of Rudyard Kipling, the Commentary on Outdoor Life of Caspar Whitney. The work of these masters in widely separated fields will be read and enjoyed exclusively in the half-million families to which Collier's goes every week.

The story told in your advertisement goes to this same half-million families—families where good things in literature, art, and MERCHANDISE are appreciated to the point of possessing.

E. C. PATTERSON Manager Advertising Department

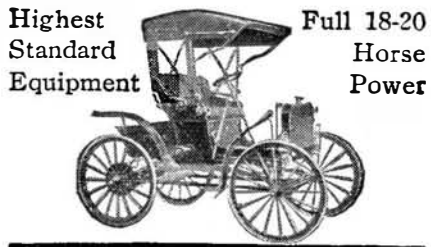

Highest Standard Equipment Full 18-20 Horse Power

This Is Quality In a High Wheel Car

Automobile experts appreciate how much it costs us to make this car the very highest standard of its type.

But find out where you get your money worth at a reasonable price in

The Only Invincible Schacht

To Remind You Schacht Mfg. Co. 2700 Spring Grove Ave., Cincinnati, O.

Send me your Automobile Catalog, post paid, free.

Name

Address

Town

State

(Cut out and mail this to us.)

WANTED, ASSISTANT CHEMIST at \$2,000 per annum, Naval Proving Ground, Indian Head, Md.

LET US BE YOUR FACTORY STAMPINGS, MODELS, EXPERT WORK THE GLOBE MACHINE AND STAMPING CO.

DON'T LET YOUR PATENT LIE IDLE. We'll make dies and tools and manufacture your article ready for market.

ICE MACHINES Corliss Engines, Brewers' and Bottlers' Machinery.

MODELS & EXPERIMENTAL WORK. Inventions developed. Special Machinery.

RUBBER Expert Manufacturers Fine Jobbing Work PARKER, STEARNS & CO.

HOEFT & COMPANY Die Makers, Model Makers, Machinery Builders, Punch Presses, Light and Heavy Stampings.

DIE MODELS SPECIAL WORK TOOLS MACHINERY NATIONAL STAMPING AND ELECTRIC WORKS

MOORE Special Machinery, Dies, Tools, Models, Metal Specialties, Inventions perfected.

New York Model and Experimental Works INVENTIONS DEVELOPED. SPECIAL MACHINERY

MODELS & EXPERIMENTAL WORK. Gears, Dies, Tools, Novelty Manufactured.

NOVELTIES & PATENTED ARTICLES MANUFACTURED BY CONTRACT. PUNCHING DIES. SPECIAL MACHINERY.

Print Your Own Cards, circulars, book, newspaper. Press \$5. Larger \$18. Save money. Print for others.

INVENTORS We manufacture METAL SPECIALTIES of all kinds, to order; largest equipment; lowest prices.

INVENTORS, MANUFACTURERS. SPECIAL TOOLS-DIES-METAL SPECIALTIES.

Dies, Models, Experimental Work; Sheet Metal Stampings. Inventions perfected.

LEARN HOW TO INVENT Our scientific lessons teach the art by correspondence. Write for free booklet.

LEARN WATCHMAKING We teach it thoroughly in as many months as it formerly took years.

SENSITIVE LABORATORY BALANCE By N. Monroe Hopkins. This "built-up" laboratory balance will weigh up to one pound.

TRADE MARKS.

Table listing various trade marks and their manufacturers, including Abrasive, crushed steel, Pittsburg Crushed Steel Co., Antiseptic salves, E. Bischoff, Asbestos slat-like building materials, fire-proof insulating, United Asbestos Co., etc.

LABELS.

Table listing various labels and their manufacturers, including "Ceres Flour," for flour, Boonville Milling Co., "Crawford" for peaches, J. H. Teats' Sons, etc.

PRINTS.

Table listing various prints and their manufacturers, including "Sapoin Gold Enamel," for gold enamel, Gerstendorfer Bros., etc.

Advertisement for Hampshire Paper Company. Text: "We say that 'clothes don't make the man,' but, except his hands and face, they're all we see of him during business hours; and they reveal a good many things in his habits and character." Includes logo for Old Hampshire Bond.

Advertisement for A.W. Faber drawing, copying and ink pencils. Text: "Drawing, Copying and Ink Pencils are the finest production of a house that has been manufacturing the highest grade lead pencils for 148 years; and has earned a reputation for excellence that has made the A.W. FABER famous all the world over."

MARK TWAIN'S Complete Works

Advertisement for Mark Twain's Complete Works. Includes a portrait of Mark Twain and a list of titles of the 25 volumes, such as 'The Innocents Abroad', 'A Tramp Abroad', 'Following the Equator', etc.

Advertisement for Harper & Brothers. Text: "WHEN you realize that all Mark Twain's books are new books, you see the great advantage of owning them—of always having new books. They never age, because humor and kindness and truth never grow old." Includes contact information for Harper & Brothers.



New Pocket Edition—Gillette Safety Razor

HERE is news indeed—for the two million men who shave themselves every morning with the Gillette Safety Razor.

Our first announcement of the latest GILLETTE achievement—the *New Pocket Edition*—the GILLETTE Safety Razor in such compact form that it can be carried like a card case in the waistcoat pocket, or slipped into the side of a travelling bag

Same size blade as before, same principle; but neater, more workmanlike, the most perfect shaving implement in the world—as compact and as beautifully finished as a piece of jewelry—and the blades are fine.

If you are a GILLETTE user call on some progressive dealer at once and examine this new razor.

If you have never used the GILLETTE now is the time to get acquainted.

You can shave yourself in from two to five minutes with the GILLETTE—a clean, satisfying shave. *No stropping, no honing.*

The pocket-case is of gold, silver or gun metal. Plain polished or richly engraved in floral and Empire designs. Inside the pocket-case are *handle and blade box*—triple silver-plated or 14-K. gold-plated. Prices \$5 to \$7.50, on sale everywhere.

You should know GILLETTE Shaving Brush—a new brush of GILLETTE quality—bristles gripped in hard rubber; and GILLETTE Shaving Stick—a shaving soap worthy of the GILLETTE Safety Razor.

New York, Times Bldg. Chicago, Stock Exchange Bldg. London Office: 17 Holborn Viaduct, E. C. **GILLETTE SALES CO.** 507 Kimball Building, Boston Canadian Office: 63 St. Alexander Street Montreal Factories: Boston, Montreal, London, Berlin, Paris



BRISTOL'S Recording Instruments



For PRESSURE TEMPERATURE & ELECTRICITY

Write for Catalogues THE BRISTOL CO., Waterbury, Conn.

BABBITT METALS.—SIX IMPORTANT FORMULAS. SCIENTIFIC AMERICAN SUPPLEMENT 1123. Price 10 cents. For sale by Munn & Co. and all news-dealers. Send for catalogue.



Low Fares to Seattle

\$62 for round-trip between Chicago and Seattle for the Alaska-Yukon-Pacific Exposition via the

CHICAGO MILWAUKEE & ST. PAUL RAILWAY

\$62 also for the round-trip between Chicago and Tacoma, Portland, Victoria or Vancouver.

Tickets on sale May 20 to September 30. Return limit October 31. Stop-overs.

Descriptive folder free.

F. A. MILLER, General Passenger Agent, Chicago

Holsman Automobiles

High Wheels Travel all Roads, Because all Roads are made to be traveled by High Wheels.

Oldest and largest makers of high-wheeled automobiles in the world. World's record for Hill-climbing and Reliability contests in this class. Only all ball-and-roller-bearing motor made. New friction-chain direct drive—no gears. Roadability and Reliability are the reasons for high wheels and solid rubber tires. Send for our catalog and learn more about these popular, intensely practicable vehicles and their low cost.



Go Anywhere

HOLSMAN AUTOMOBILE CO. Suite 119 Monadnock Bldg Chicago

PIERCE Motor Boats and Motors

"ALWAYS DEPENDABLE"

Superior to all others for Safety, Comfort, Durability and Speed. Our 24 years' experience enables us to give you the best for the least money. 33 sizes and styles of Motor Boats ranging in price from \$75.00 to \$4,000.00. Motors only, 2 to 20 H. P.

Knock Down Boat Frames with Machinery. Row Boats and Canoes. Write today for full particulars. We can save you money.

PIERCE ENGINE CO. Racine, Wis. Twenty-fourth Ave., Siegel, Cooper Co., New York City, Eastern Agents

Fractional Adding & Subtracting Rule

A practical, useful and time-saving device for students in engineering schools, machine designers, mechanical and civil engineers, &c.

Adds and subtracts fractions for you, eliminating tiresome figuring and insuring absolute accuracy. You can't make a mistake. Full directions for using. Your money back if not in every way satisfactory. Endorsed by leading instructors in mechanical schools and by practical mechanical men in all fields. Send today. Price \$1.00. Address Burgess & Sauerberg, Desk G, Kortlander Bldg., Grand Rapids, Mich.

LUFKIN TAPES AND RULES

ARE THE BEST.

For sale everywhere. Send for Catalog No. 16.

LUFKIN RULE CO. Saginaw, Mich., U. S. A. New York and London.

HELMET OIL LUBRICATES FOR ANYTHING

SEND FOR SAMPLE

15-21 S. CLINTON ST. CH. BESLY & CO. CHICAGO, U.S.A.

Model "R" Roadster

Close coupled body seating four



Can be furnished with Runabout Body seating two

Glide \$2250

This 45-H.-P. Car Sells for \$2250 and Represents \$2250 of Automobile Value

If you are willing to be done, any machine will do. —And that is just as true of an automobile as it is of any machinery you use in your business.

—Sometimes in the manufacturing business, it seems wise, for reasons of expediency, to buy cheaply. But there is too much demanded from an automobile to expect a cheaply bought car to give satisfaction even temporarily.

—As is the case with other machinery, when you are ready to part with it, you will find your cheap automobile nothing but a pile of junk and your pocketbook suffers by a many times multiplied percentage of depreciation.

—You should exercise the same common sense and business judgment in buying an automobile that you would use in any business investment. —Don't be misled by the extravagant claims made for very low-priced cars—nor the claims made for a very high-priced car.

—The features of the GLIDE are revolutionary and distinctive when the price is considered. They are built in, made an integral part of the car. —None of them are found in very low-priced cars. But few of them are found in very high-priced cars.

But Read and See—Then Ride and Know

—The power plant is a 4-cylinder (cast separately) 45 actual not theoretical) H. P. Rutenber engine. This is a grade never found in the widely heralded low-priced cars. The price alone makes it possible in the Glide.

—An improved form, selective type of transmission which eliminates jerks when starting and jolts when stopping.

—A bevel driving gear of ample size—held always in mesh by its own special bearings.

—Vanadium steel springs which do away with the need of shock absorbers.

—There is no more graceful car made. Its appearance suggests strength, reliability and that quiet purposeful performance which gives it the name—Glide.

—Detailed information will interest you if you are seeking a standard car of the best type at a price fixed at the point of safety. Write us today. We invite comparison and an opportunity to demonstrate.

THE BARTHOLOMEW COMPANY Standard Manufacturers A M C M A. 603 Glide St., Peoria, Ill. Glide Model "G" Special Touring Car, seats 7; wheel base 120 inches; 34x4 1/2-inch tires—\$2,500.

COLD GALVANIZING. AMERICAN PROCESS NO ROYALTIES

SAMPLES AND INFORMATION ON APPLICATION

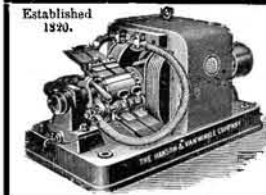

Established 1920. **NICKEL** AND Electro-Plating Apparatus and Material THE Hanson & Van Winkle Co., Newark, N. J. 28 & 30 S. Canal St. Chicago.

Can You Tell a Nut From a Bolt? IF SO \$350 BUYS THIS \$600 HIGH-GRADE RUNABOUT



THE METZ PLAN CAR

This "Plan" will appeal to you. Send for Book "S" C. H. METZ, Waltham, Mass.

NEW CATALOG

We have just issued our 9th Catalog and the pocket size is now ready for distribution. This new No. 9 Catalog contains 272 pages and shows many tools not included in the earlier editions. Just say that you would like one.

GOODSELL-PRATT COMPANY Greenfield, Mass., U. S. A.

Rider Agents Wanted

in each town to ride and exhibit sample 1909 model. Write for Special Offer. Finest Guaranteed Models \$10 to \$27 with Coaster-Brakes and Puncture-Proof tires. 1907 & 1908 Models \$7 to \$12. 500 Second-Hand Wheels. All makes and models. Good as new. \$3 to \$8. Great Factory Clearing Sale. We Ship On Approval without a cent deposit, pay the freight and allow TEN DAYS' FREE TRIAL. Tires, coaster-brakes, parts, repairs and sundries, half usual prices. Do not buy till you get our catalogs and offer. Write now. MEAD CYCLE CO., Dept. L175, Chicago

The Ball Transmission FOR Automobiles & Motor Boats

NEW YORK GEAR WORKS