

SCIENTIFIC AMERICAN

[Entered at the Post Office of New York, N. Y., as Second Class Matter. Copyright, 1909, by Munn & Co.]

Vol. C.—No. 12.
ESTABLISHED 1845.

NEW YORK, MARCH 20, 1909.

[10 CENTS A COPY
\$3.00 A YEAR.]

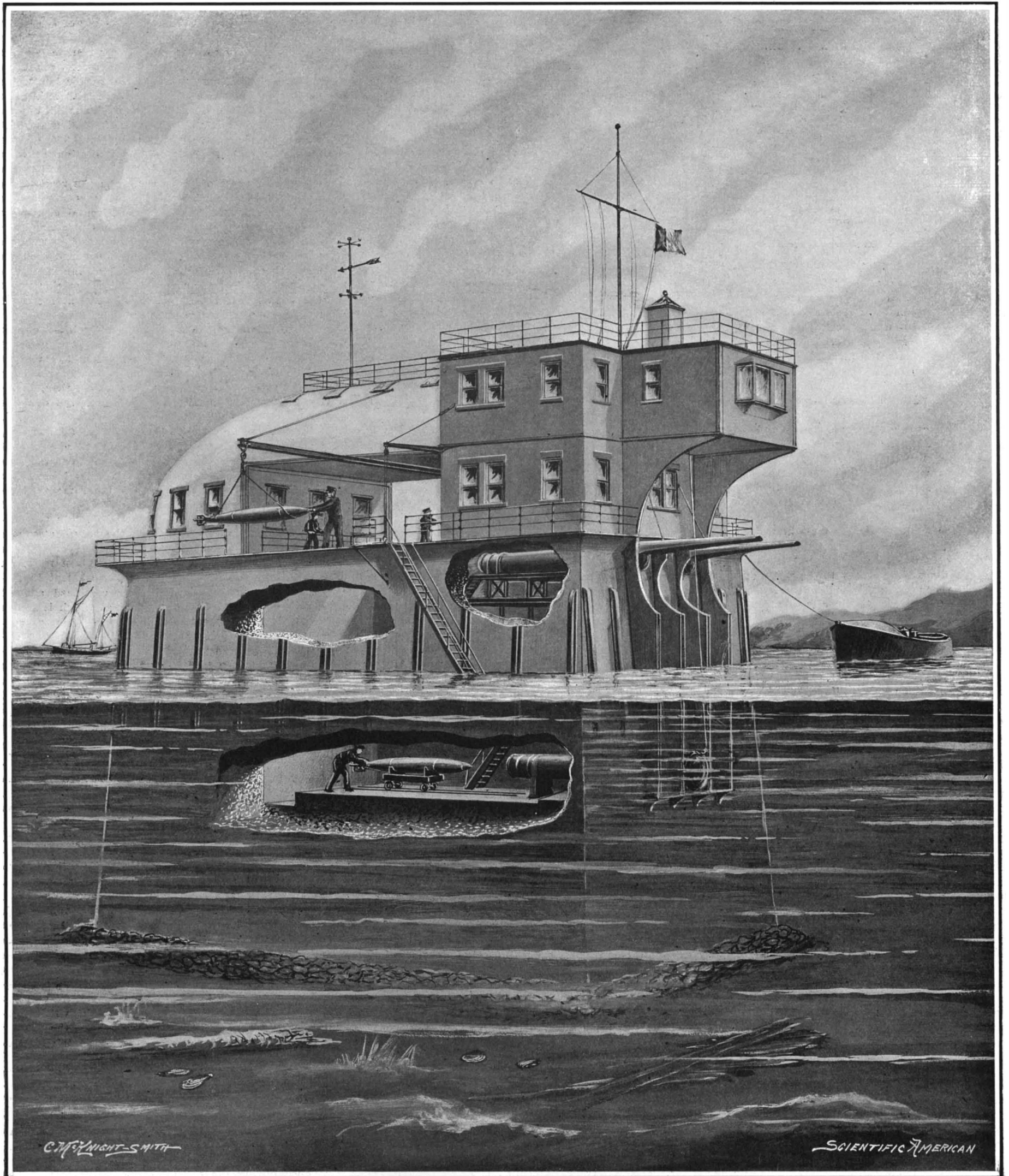

In this building the Schneider Company adjust and put in first-class running condition the new torpedoes built in their shops. The above-water launching tubes are seen below the projecting observation room. Below is seen a submerged launching tube.

A TORPEDO TESTING AND LAUNCHING STATION.—[See page 222.]

SCIENTIFIC AMERICAN

ESTABLISHED 1845

MUNN & CO. - - - Editors and Proprietors

Published Weekly at

No. 361 Broadway, New York

CHARLES ALLEN MUNN, *President*,
361 Broadway, New York.FREDERICK CONVERSE BEACH, *Sec'y and Treas.*
361 Broadway, New York.

TERMS TO SUBSCRIBERS.

One copy, one year, for the United States or Mexico \$3.00
 One copy, one year, for Canada 3.75
 One copy, one year, to any foreign country, postage prepaid, 18s. 6d. 4.50

THE SCIENTIFIC AMERICAN PUBLICATIONS.

Scientific American (established 1845) \$3.00 a year
 Scientific American Supplement (established 1876) 5.00 "
 American Homes and Gardens 3.00 "
 Scientific American Export Edition (established 1878) 3.00 "

The combined subscription rates and rates to foreign countries, including Canada, will be furnished upon application.

Remit by postal or express money order, or by bank draft or check.

MUNN & CO., 361 Broadway, New York.

NEW YORK, SATURDAY, MARCH 20th, 1909.

The Editor is always glad to receive for examination illustrated articles on subjects of timely interest. If the photographs are *sharp*, the articles *short*, and the facts *authentic*, the contributions will receive special attention. Accepted articles will be paid for at regular space rates.

THE MENACE OF THE NOISELESS GUN.

The noiseless gun, of which we gave an illustrated description in our issue of February 20th, 1909, must be regarded as one of the most successful inventions of the day. As a means of securing that secrecy in warfare which is essential to successful tactics, it is equal in importance to smokeless powder. To meet the attack of an enemy that can be neither seen nor heard will be a problem indeed, and the inventor is to be congratulated upon having introduced into warfare one more of those exacting conditions which are tending to make modern warfare so costly and destructive as to prohibit it altogether. In so far as the Maxim gun silencer renders war more difficult, it may be regarded as making indirectly for the preservation of peace, and, therefore, if we choose to so regard it, for the betterment of international conditions.

If it were possible to confine the possession of the new weapon to the military, for whose use, and for whose use alone, it was designed, we would have nothing to say against the device. But it cannot be denied that the appearance of this gun has greatly enlarged the opportunities for the commission of undetected crime. This fact is clearly realized by the Police Department of this city; and already the chief of police of the city of Pittsburg has taken steps to prevent the carrying of noiseless guns, and has announced his intention to prosecute, with the utmost severity that the law allows, all persons who are found in possession of the silencing attachment.

It is well understood that fear of detection is one of the most powerful deterrents to the commission of crime. It is because it does its work so silently that certain races prefer the knife or the stiletto to the rifle and revolver. The menace of the noiseless gun lies in the fact that the man with murder in his heart may now dispatch his victim in silence. Rarely does the burglar break into the home of the private citizen unarmed; and yet it is a fact, well understood by the police, that the last thing he desires is to be driven to use a revolver. But the housebreaker who carries a "silencer" might shoot the owner without the slightest fear of the report being heard by watchman or patrol, or even by the inmates of other rooms in the house. The new weapon is surer than the blackjack. A belated pedestrian might be shot, and the robbery of his person carried out, without the police on adjoining streets having the slightest suspicion that a crime was being committed. Not even the cover of night will be necessary for the concealment of deeds of violence. The fatal bullet can be sent to its mark on a crowded thoroughfare and in broad daylight, without there being any evidence of smoke or report to show whence it came.

The deadly character of the noiseless gun renders it, in the hands of unscrupulous people, a distinct menace to society; and we are strongly of the opinion that it should be made the subject of immediate and very stringent legislation. The principle upon which such a law would be founded is already recognized in the penalties which are attached to the carrying of concealed weapons. The frightful possibilities of undetectable crime, which are opened up by the appearance of this weapon, should be met by a statute declaring that the manufacture, sale, or possession of this weapon, for any but strictly military purposes, is a felony, and punishable by a long term of years in the penitentiary.

OPPORTUNITY FOR AMERICAN STEEL CONSTRUCTION AT MESSINA.

The United States consul at Naples has drawn attention in a recent report to the promising opening for American capital and enterprise in connection with the rebuilding of the city of Messina. It seems that the sentiment of the people is entirely in favor of reconstruction. Large sums of money have been expended in the improvement of the harbor, whose site and general excellence are such as to render its abandonment out of the question. Although, as yet, no definite plans have been formulated by the government, it is generally understood that, as soon as sanitary considerations will permit, the work of removing the debris of the city will be energetically carried through. It will be several months, however, before this work will be commenced.

In view of the fact that there will be a strong demand for the construction of houses that are both fireproof and proof against earthquake, the situation will offer an unrivaled opportunity to introduce American methods of building construction. The San Francisco disaster was made the subject of a very thorough investigation by our architects and engineers, and its lessons were carefully gathered and recorded. It was proved that the steel frame building, particularly in cases where the walls were carefully tied into the steel framework, is admirably adapted to resist earthquake stresses. Reinforced concrete construction, also, showed, in the limited amount of such work as existed in San Francisco, that, with certain modifications, it could be made proof against serious damage by earthquake. In the intervening years, great advance has been made in our knowledge of the strength, and best methods of design, of reinforced concrete; and this system of construction, if it were applied to the rebuilding of Messina, would be an ideal form, especially for buildings of moderate height. Our consul pertinently suggests that, in addition to the presentation of plans and estimates for rebuilding, American firms will find it greatly to their advantage to be represented on the spot by intelligent agents who are experts in the class of construction that is recommended.

THE SUBWAY SITUATION.

If the publication of plans and the submitting of proposals to the Public Service Commission is a guarantee of an early enlargement of rapid transit facilities in New York, the outlook for the future is rosy indeed. The company which is responsible for the Hudson tunnels has offered to extend its system by way of Sixth Avenue and Forty-second Street to the Grand Central terminal. The Interborough Company has proposed to enlarge its present system by the construction of a two-track subway from far north in the Bronx to the Battery, by way of Lexington Avenue and Seventh Avenue, and to increase the facilities of its elevated system by laying a third track for express service on its Second and Third Avenue systems; also it asks permission to lengthen the present subway platforms, to admit of the operation of ten-car express and six-car local trains. The Public Service Commission has announced that it is completing plans for a four-track system by way of Lexington Avenue and Broadway, to be built for most of the distance on two levels, with the local tracks above the express. It is understood that the Public Service Commission is disposed to grant the application of the Hudson Tunnels Company on the ground, not only that it will furnish a most important cross-town service connecting the steam railroads which enter the Grand Central station with those that terminate in New Jersey, but that it will bring the Sixth Avenue shopping district into convenient touch with the steam and electric roads, long-distance and local, of the east side of Manhattan Island. In granting this franchise the Public Service Commission will undoubtedly have the hearty indorsement of the general traveling public. The Commission is not disposed to grant the application of the Interborough Company, and this chiefly for the reason that it considers its own plans for a Lexington-Broadway four-track system to be greatly superior in convenience and capacity to the two-track systems proposed by the company. The request for permission to lengthen the existing subway platforms will undoubtedly be granted; for this change alone will result in an increase of the carrying capacity of the subway about twenty-five per cent. Moreover, it can be accomplished for \$1,000,000—a very moderate outlay for an increase of carrying capacity of from 150,000 to 200,000 per day. The proposal to add a third track on the Second and Third Avenue elevated roads is certain to meet with popular opposition, on the ground that the existing elevated roads are a disfigurement to the city, and that to increase the trackage would further darken the streets. In view of the loosening up of the East Side congestion during the rush hours, which would result from the addition of these express tracks, we think that the Commission should hesitate before finally turning down this part of the Interborough's proposal.

LIMITATIONS OF THE HYDROPLANE.

The hydroplane is regarded as such a distinctly recent invention, that it will doubtless surprise many yachtsmen to learn that, as far back as the year 1872, the theory of this type of boat was most exhaustively investigated by William Froude, the father of the modern theories of the resistance of ships. According to our contemporary, the Yachting and Boating Monthly, the experiments carried out at Torquay, England, were made with two models, respectively 3½ and 10 feet in length. The lift and speed were recorded by special automatic apparatus. Mr. Froude found that the maximum resistance of a 2,500-ton ship would not be obtained until a speed of over 120 knots was reached. The first of the series of deductions arrived at was that even if by some extraneous means the ship could be started at the tremendous speed necessary to lift it completely out of the water, it would be impossible for the boat to carry the horsepower necessary to overcome the air resistance alone. Furthermore, if a ship were being driven along the surface of the water at a speed of say 60 knots, and met a wave of twice her own length with 10 degrees of maximum slope, she would be launched upward at that angle, and would take a flight of nearly 100 feet before she again reached the water. The upward impulse would involve the communication of some rotational motion, which would inevitably add to the destructive effect of the shock when she reached the next sea. The final investigation was directed to the determination, first of the horizontal component of the normal pressure on the inclined plane, and secondly of the surface friction of so much surface as remains immersed. Mr. Froude's demonstration, as far back as 1872, of the fact that the inherent principles of the hydroplane prohibited the attainment of the phenomenal speeds which its advocates claimed for it, is summed up as follows:

If when the ship has become wholly lifted on the inclined plane we seek to diminish that element of resistance which consists of the horizontal component of the weight supported on the incline, by reducing, say halving, the steepness of the plane, then, in order that with this flattened inclination the dynamic action of the water should yield the same support, the plane must assume a doubled area of immersion, and this doubled area will involve a doubled frictional resistance. But if again we seek to diminish the area of immersion by increasing the speed, the friction per square foot will be increased in the same ratio as the lifting force per square foot, and the immersed surface, though reduced in area, will retain the doubled frictional resistance which the halved steepness of the inclination introduced. Thus, while we reduce one element of the resistance in any given ratio, we at the same time increase the other element in precisely the same ratio, and their combined amount cannot be reduced below the limit at which it stands when the two elements are equal.

If the limitations of the hydroplane, as thus disclosed thirty-seven years ago by Mr. Froude's investigations, had been known, or fully understood during the recent revival of interest in this attractive device, much misdirected effort and inevitable disappointment would have been avoided.

AVIATION IN AMERICA AND THE SCIENTIFIC AMERICAN TROPHY.

Judging from the recent performances of Mr. McCurdy in Nova Scotia with the fourth aeroplane—the "Silver Dart"—of the Aerial Experiment Association, the year 1909 is to witness even more rapid progress in aviation here than was made in France last year.

After having made comparatively few practice flights, this young Canadian engineer, on March 10th, increased his previous records to nearly 20 miles in two flights of 13 and 22 minutes duration respectively. Two days before he had already made a flight of 11 minutes duration. The aeroplane, mounted on wheels, started and landed on the ice of Lake Bras d'Or, near Baddeck, N. S. In one of the flights this new aviator is said to have attained a height of 50 feet and to have performed various evolutions. At his request, the Aero Club of America is sending a representative to Nova Scotia to officially control a flight for the SCIENTIFIC AMERICAN Trophy, which it has recently been decided to award each year to the aviator who makes the longest flight in an official trial. Hereafter, anyone having a heavier-than-air machine which has shown itself capable of flight can have an official trial by notifying the Aero Club of America two or three days in advance, and remitting double the railway fare from New York to the point of trial, plus \$4 for each day upon which a trial is to be made. The minimum distance for 1909 is 25 kilometers (15½ miles). If a sufficient number of machines are developed during the next few months, it is probable that a contest will be arranged near New York city.

The SCIENTIFIC AMERICAN Trophy has served a useful purpose in encouraging the development of new flying machines. From now on it will stand for the greatest achievement in aviation in America.

ENGINEERING.

Now that the misunderstandings between the railroads and the manufacturers have been removed and a satisfactory steel rail assured, orders for new rails are being placed in large quantities. A notable instance is a recent order of the New York Central Railroad for 101,000 tons to be delivered during the spring and early summer. Of this order, 51,000 tons are being rolled by the Lackawanna Steel Company, 42,600 tons by the United States Steel Corporation, and the balance by the Algoma Steel Company and the Bethlehem Steel Company.

The first application in England of the single-phase current to the operation of a steam railway is that on a section of the Midland Railway from Heysham to Morecambe and Lancaster. It involves electrification of ten miles of double-track road, and the equipment consists of overhead transmission, fed with single-phase alternating current at 6,600 volts and 25 cycles. Also, a section of the London, Brighton, and South Coast Railway, nine miles in length, is being furnished with overhead electric transmission, and the total length of single track that is being equipped is 23 miles. Current will be furnished by the London Electric Supply Corporation.

A vivid impression of the huge amount of material that enters into the construction of the great bridges which are being built across the East River, may be gained by a visit to the storage yard at Bayonne, where the steel for the construction of the roadways, floors, trusses, etc., of the new Manhattan Bridge has been gathered for shipment to the site as it is needed. The stack of metal, before removal to the bridge began, weighed 30,000 tons, was 35 feet high, 85 feet wide, and 800 feet long. The steel was manufactured at Phoenixville, Pa., and it required 1,600 flat cars to transport it to Bayonne.

A recent statement made by Baron Saito in the naval section of the budget committee, at Tokio, regarding the strength of the Japanese navy, shows the absurdity of regarding that navy, excellent as it is, as a competitor on equal terms with our own navy. The active list of the Japanese navy includes 13 battleships, 12 armored cruisers, 43 other cruisers, 59 destroyers, and 69 torpedo boats. Some of the important new ships are yet far from completion. The armored cruiser "Ibuki" and the battleship "Satsuma" are to be completed this year; but the armored cruiser "Kurama" and the battleship "Aki" will not be ready until 1911.

The gain in toughness and strength of steel, due to the introduction into the construction of a small percentage of vanadium, is shown in some recent comparative tests of a carbon steel frame of 78,000 pounds tensile strength and 46,000 pounds elastic limit, and a frame of similar section with vanadium added to the steel composition. The vanadium steel frame section, carried on supports four feet apart, stood twenty blows of a 5,000-pound weight falling from a height of 18 feet, before fracture took place. The carbon steel frame section was deflected 5 1/2 inches by the first blow and broke on the second. In the whole series of tests the vanadium steel showed about 15 per cent higher tensile strength and 25 per cent greater elastic limit than the carbon steel.

On March 9th there was laid at the Brooklyn navy yard the keel plate of the "Florida," which on the day of her launch will be the largest battleship afloat. A sister ship, the "Utah," is being built by the New York Shipbuilding Company, Camden, N. J. The "Florida," 521 1/2 feet over all, will have 88 feet 2 1/2 inches beam, or a few inches more than the "Mauretania." Her normal displacement will be 21,825 tons, her full load displacement 23,034 tons. She will be driven by 28,000-horse-power Parsons turbines at a speed of 20 3/4 knots. Her armament will consist of ten 12-inch and sixteen 5-inch guns. As a result of the economies due to consolidation of the bureaus, our naval constructors expect with this ship to make a new record for rapidity of construction.

The Brennan gyrostatic monorail was introduced to the New York public by Prof. Chessin, of Washington University, St. Louis, in the course of a recent lecture at Columbia University. Demonstrations were made with a 15-pound model running upon a copper wire. The automatic balancing mechanism consisted of two fly-wheels whose weight was 1/20 of the weight of the whole car, and the model contained all the essential features of the large car, for the development of which the British government has appropriated a large sum of money. While the car was running upon the wire, weight, which it successfully balanced, was gradually added upon one side of the car, which did not lose its equilibrium until a load equivalent to about 2/3 of its own weight had been placed eccentrically upon its platform. According to the lecturer, the gyroscope, in a full-sized car, would constitute about 5 per cent of the total weight and occupy about 15 per cent of the total space.

ELECTRICITY.

A novel desk lamp has recently been put on the market, which consists of a long glass tube in which the filament instead of being coiled is stretched out in a single horizontal line. The entire light is projected downward on to the desk by means of a semi-cylindrical reflector. The result is that the light is distributed over a larger area, and is more diffused than with the ordinary incandescent bulb.

The frequency of accidents to passengers alighting from the rear platform of one car and walking in front of a car approaching from the opposite direction, has led an inventor to devise an alarm which is sounded by the motorman when he stops his car if he sees another car coming on the opposite track. The alarm is located on the back platform, and at night the device is illuminated, so that the sign reading, "Look out for the car on the other track," may be read.

A novel telephone receiver without a diaphragm has recently been devised, for which many advantages are claimed. It consists of a permanent magnet, the poles of which are connected by a soft core, making a continuous magnetic circuit. A coil wound around this core is connected to the transmitter and a suitable battery. When the transmitter is spoken into, the undulatory current affects the entire magnetic circuit of the receiver, reproducing the voice very distinctly. It is said that with this receiver there are no overtones or disturbing sounds due to the vibrating of a diaphragm. In one modification of this telephone the sounds were produced with such clearness as to fill a large hall.

A new type of coffee roaster is now being made, consisting of an inner stationary and an outer rotating cylinder of perforated steel, between which the coffee beans are placed. The inner cylinder is electrically heated, and the beans are mixed thoroughly to provide a very even roast, by means of blades which operate in the space between the cylinders. One of the objections to the ordinary roaster is the fact that it must be opened to permit of sampling the contents, to determine when the beans have been properly roasted. In the new electric roaster a small cup is provided, which may be operated by the pressing of the knob to throw out three or four beans without stopping the cylinder, thus enabling the operator to sample the roasting.

In a recent issue of the Electrochemical and Metallurgical Industry, M. U. Schoop discusses the decomposition of water by means of electricity to provide gases used in the oxyhydrogen welding flame. The proportion of 1 volume oxygen to 2 of hydrogen is not suitable for welding metals, as the oxyhydrogen flame should have an excess of hydrogen. However, M. Schoop has found that by using acidulated water, the proper proportion of oxygen and hydrogen may be obtained. This result he achieved in experiments which had to be discontinued, and he suggests that others should take up this problem, and try it out with a view to obtaining a commercially practical system of producing directly the gases necessary for the oxyhydrogen flame.

Much has been done abroad in developing the electric furnace for refining steel. Although little has been done heretofore in this line, in this country, the decision of the United States Steel Corporation to install two Héroult electric furnaces, of much larger capacity than ever before built, shows that we have been closely watching the experiments of others, and are now ready to profit by the work they have done. One of the Héroult furnaces is to be used at South Chicago, to produce an extra fine steel for rails. The metal will be taken from a Bessemer converter, and then refined in the electric furnace. The furnace will have a capacity of 15 tons, and if it proves a success, furnaces of twice this capacity will be installed. The second Héroult furnace is to be installed at Worcester, to refine steel used in making wire. Here the furnace will be used in conjunction with the open hearth.

Another "C. Q. D." message has awakened the public to the importance of equipping all ocean-going vessels with wireless telegraph apparatus. In the case of the collision between the "Horatio Hall" and "H. F. Dimock," this importance was more strikingly shown than in the previous collision between the "Florida" and the "Republic." The passenger steamer was equipped with wireless telegraph apparatus, but the injury it received was so serious, that the operator had no time to send out any detailed information about the accident or its whereabouts. Although the passengers were taken aboard the "Dimock," considerable anxiety was felt for their safety, owing to the absence of further wireless messages. The freight boat with the passengers aboard was in a precarious condition, but could summon no assistance because it possessed no wireless outfit. Had the law been in force compelling all vessels to carry wireless telegraph apparatus, it would have been possible for the "Dimock" to communicate with the revenue cutter "Gresham," which was searching for it in the fog.

SCIENCE.

In an obituary notice of the late Mr. Ezram von Jerzmanowski we stated that he was the introducer of the water-gas process in this country. A subscriber of the SCIENTIFIC AMERICAN questioned this statement, and held that the honor belonged Mr. T. S. C. Lowe. We are informed by Dr. Arthur H. Elliott, engineer-chemist of the Consolidated Gas Company, that the credit of the introduction really belongs to M. Tessie du Motay, the inventor of the water-gas process, and that Mr. von Jerzmanowski was an assistant of his. Mr. T. S. C. Lowe modified Du Motay's process, and made it practically continuous.

Mrs. W. K. Vanderbilt's plan of building in New York city four model tenement houses for tuberculous families deserves praise. What the tuberculosis patient needs, and what he can get only in a well-conducted hospital or sanitarium, is intelligent supervision of his sleeping quarters. According to Mrs. Vanderbilt's scheme, the families to be housed in her model tenements will be thus supervised until they can safely live elsewhere. A particularly valuable feature of her plan is the fact that it tends to keep the family together. The dispersion of the family undoubtedly has its bad effect upon the patient himself, and frequently results in the separation of the entire family.

The recent newspaper announcement of the discovery by two homeopathic physicians of "Tho-rad-x," "the most powerful therapeutic agent in the world," which like all other cure-alls "will revolutionize the practice of surgery," has been made the butt of ridicule in serious medical papers. It is asserted that radium has hardly lived up to the promises which were originally held out. After all, it must be confessed that we are still much in the dark as to the therapeutical value of radioactive substances. The indiscriminate publication of such "discoveries" cannot but have an evil effect in so far as they arouse false hopes.

Capt. C. E. Thomas of Saranac Lake has discovered an opening to a great cavern on the summit of a mountain in the Adirondacks, N. Y. He penetrated the cave for about 1,000 feet, and then returned because he had no proper equipment to continue his exploration. The cave is situated on a mountain known as "W" Mountain, several miles from Standish, N. Y. The mouth of the cave is about 50 feet wide, and the first room 50 feet long, 20 feet wide, and 30 feet high. Bats lined the walls. In the second room, which was about 40 x 15 x 25 feet, ramified passages were found.

On April 9th, 1908, an inverted rainbow was seen from the Italian geodynamic observatory of Rocca de Papa by Prof. Agamennone, the director of the observatory, and a party of visitors. The morning was showery; and when the visitors reached the observatory, 2,500 feet above sea level, and looked down on the vast Campagna, they were astonished to see, projected on the vineyards and trees beneath, a perfect rainbow with its convex side down and its middle point bearing northeast. Inverted rainbows are very rare, even in mountainous regions. None of the visitors, who were French and Italian meteorologists, had ever seen one, nor had Prof. Agamennone, although he had been director of the observatory for eight years. The phenomenon, however, is not unknown. It was observed from the Eiffel Tower in Paris in April, 1891. In this case there was a double rainbow, extending above and below the horizon to form two nearly complete concentric circles.

Last July Drs. Soubbris and Crouson, with the aeronaut Decugris, made a balloon ascension for the purpose of studying the cause of "balloon sickness," which has been ascribed both to deficiency of oxygen and to deficiency of carbon dioxide in the blood; Agazotti going so far as to recommend, for inhalation at great altitudes, a mixture of 13 per cent of oxygen and 87 per cent of carbon dioxide, in preference to pure oxygen. Dr. Soubbris, who alone suffered from balloon sickness in this ascension, experienced six distinct attacks; of which three were relieved by Agazotti's mixture, and the others were cured, far more completely, by pure oxygen, which therefore appears preferable for inhalation. Various other observations were made during the ascension. The arterial pressure was found to vary irregularly, with the altitude and the individual. The muscular strength of two of the men diminished regularly as the altitude increased, while in the third case the strength first diminished and then increased, as the following table shows:

Altitude.	Muscular Strength		
	No. 1.	No. 2.	No. 3.
0	45	57	41
13,120 feet	38	38	42
11,800 feet	42	51	39

No definite law of variation of cutaneous sensibility could be detected with Weber's compass. Bonnier's diapason also gave negative results in regard to acuteness of hearing.

IMPROVED FORMS OF THE BUGGY-TYPE AUTOMOBILE.

The modern motor buggy is an example of reversion to an original form, as can be seen by comparing photographs of some of the machines herewith illustrated with those of the Selden car, shown on another page. The pioneer automobile builders generally sought to place a motor upon a horse-drawn vehicle, and thus make it self-propelled, and as horse-drawn vehicles generally had large wheels, these were also used upon the first American automobiles, such as those produced by Haynes and Duryea.

Some six or eight years ago Mr. Holsman, of Chicago, reverted to the old scheme of applying a motor to a high-wheeled buggy. The machine had novel features, such as a rope drive, compact power plant, etc., and it showed itself capable of traveling over extremely bad and muddy roads with considerable facility. The use of solid rubber tires did away with all tire trouble, and in the hands of the actual user these machines gave thorough satisfaction. They were gradually improved in details and the latest change has been the substitution of a four-cylinder opposed-type motor of novel design for the double-opposed-cylinder motor that has heretofore been used. A partially-sectioned plan view of this motor is shown below. The opposed pistons in each pair of cylinders are rigidly connected, the frame that unites them having a vertical slot in which is mounted a roller bearing. An eccentric disk on the motor shaft (which takes the place of the crank) fits in this roller bearing, and the back-and-forth horizontal movement of the pistons rotates the eccentric and thus the motor shaft of which it forms a part. The up-and-down movement of the eccentric is allowed for by the roller rolling up one side of the slot in the piston-connecting frame, and down the other. There is a clearance of 1/1000 of an inch between the slot and the roller, so that it clears on the side of the slot at which there is no pressure while moving up or down the other side. The motor shaft is mounted on ball bearings and is extended outward on either side of the carriage body. At and near each end there are two V-shaped pulleys. The outermost one presses against the tires of the rear wheels and reverses the vehicle when the motor is swung backward on its two hangers. The other pulleys near each end of the motor shaft drive the rear wheels by means of a special new form of friction chain which runs over large sheaves on the rear wheels. For the low speed a positive drive is obtained by spreading the driving pulleys and allowing the chain to fall on a small sprocket at the center of each one. This is an extremely novel feature and is an excellent one, as it gives a practically positive drive on the low speed which sometimes has to be used in pulling the vehicle out of a hole. Another novel feature of this new motor is the drawing of the charge of gas into the crank case, whence it passes through automatic inlet valves in the heads of the pistons into the cylinders. By dissolving the lubricating oil in the gasoline, all the working parts of the motor are thoroughly lubricated as the charge is drawn into the crank case. The exhaust valves are located in flanged chambers on the sides of the cylinders and are operated by a slotted cam on the motor shaft, thus dispensing with all cam gears. The exhaust passes through a pipe into a muffler which surrounds the motor shaft and is entirely separated from it. The new motor has a bore and stroke of 4 inches and is rated at 26 horse-power. It is of the air-cooled type, which is the type usually employed in this class of machine on account of its simplicity and economy. It is mounted under the center of the vehicle body and is readily accessible by taking up the floor. The success that at-

tended the Holsman machine caused others to take up the manufacture of this type of automobile, and there are at the present time fully half a hundred makers of high-wheeled buggy-type automobiles throughout the United States. Most of these conform more or less closely to the lines laid down by Holsman, though there are some variations in the form of drive and of motor used. For instance, in the McIntyre machine, and also in the International, the double-opposed air-cooled motor has a planetary two-speed transmission mounted directly upon the crankshaft and arranged to drive a countershaft, placed at the rear, by means of a single chain. The final drive to the rear wheels is by double chains from the ends of this countershaft. A good idea of this arrangement is to be had from the

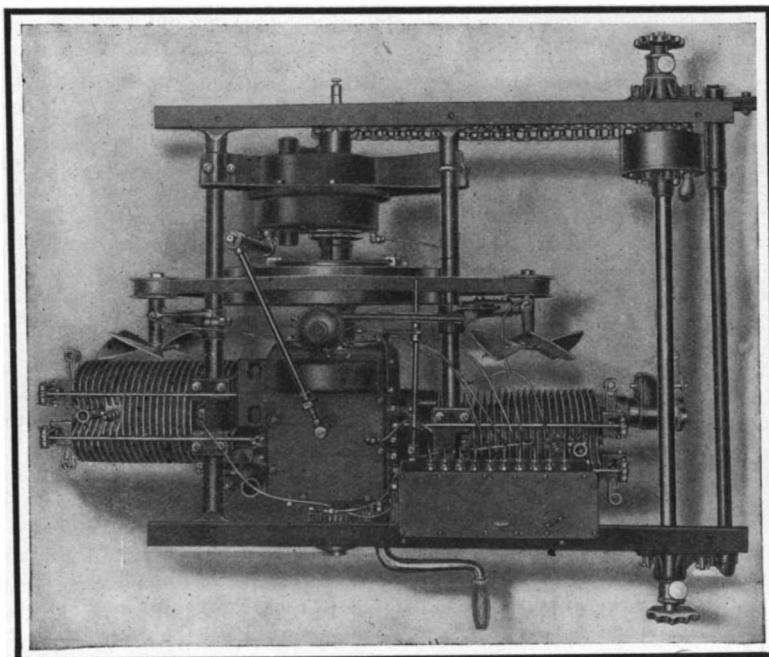

Power plant of the International motor buggy.

This is a typical power plant having an air-cooled double-opposed-cylinder motor with offset cylinders and all mechanically operated valves, direct-connected to a two-speed-and-reverse planetary transmission a single chain from which drives a countershaft carrying a differential. Two chains from the end of this countershaft drive the rear wheels. A novelty is the two fans ingeniously driven by a belt passing under and over the flywheel. The motor is thoroughly lubricated by a mechanical oiler having ten outlets.

plan view of the power plant of the International automobile buggy. In this case special fans are arranged to blow upon the exhaust valve chambers and keep them well cooled, while the lubrication is effected by means of a mechanical oiler positively driven from the motor crankshaft. A powerful 5 x 5 opposed-cylinder motor of 14 brake-horse-power is used in this car. The motor is mounted upon a steel sub-frame, and its location in the center of the vehicle makes an equal distribution of weight. The body is mounted upon four full-elliptic springs 3 feet in length. The wheels are 40-inch diameter in front and 44 in the rear, and they are fitted with special flat-tread solid rubber tires of 1 1/4 inches diameter. Internal expanding brakes are fitted in the sprocket drums.

The McIntyre machine has a motor of 4 1/8 x 3 3/4 inches bore and stroke, rated at 12 to 14 horse-power. The wheels are fitted with 1 1/4-inch solid rubber tires and contracting ring brakes are used on the driving wheels. The front and rear wheels are 34 and 38 inches in diameter respectively. This concern has

recently brought out a large four-passenger automobile with a four-cylinder vertical motor placed in front under a bonnet and with shaft drive through a two-speed planetary transmission to the rear axle. The motor used on this car has the same bore and stroke as the other and is rated at 28 to 32 horse-power. The use of solid tires on a large car of this kind necessarily limits the speed at which it can be regularly driven to not much more than 20 miles an hour; but for certain purposes the solid tire is preferable on account of its reliability and freedom from puncture.

Still another variation in the power plant of the medium-priced buggy-type machine is to be found in the Schacht runabout, in which a water-cooled double-opposed-cylinder motor is mounted transversely in the box at the rear of the body and is arranged to drive, by means of a composition alloy metal disk attached to its flywheel, a paper-rimmed wheel mounted upon a countershaft forward of the motor. This wheel contains a differential in its hub—a feature that is necessary in order to allow a difference in speed of the driving sprockets on the ends of the countershaft when the vehicle makes a turn. The drive to the rear wheels is by two side chains. The radiator used as a dash-board is a novel feature of this machine.

One of the simplest buggy-type automobiles yet devised is the "Buggyaut" of the pioneer automobile constructor, Mr. Charles E. Duryea. This machine is fitted with a two-cylinder, two-cycle, air-cooled motor of about 12 horse-power. The bore and stroke of the cylinders are 3 3/4 inches respectively. The motor is mounted in a horizontal triangular frame the base of which is formed by the extensions of the motor crankshaft through suitable casings. These tubular casings contain spiral pockets, A, and flanges upon the motor shaft extensions fit in the pockets. By rocking the tubular casing the shaft extensions are thus moved sideways and the two grooved pulleys at their ends are brought opposite the grooved rings on the wheels to obtain the low or high speeds. The frame containing the motor is then swung forward until the pulleys are brought into mesh with the rings sufficiently tightly to drive them by friction.

The drive is similar to that of a locomotive upon rails, except that in this case the rails are round and grooved, thus making greater frictional contact and lessening the pressure required. The pulleys are made of steel, and the rings, which can be readily and cheaply renewed in a few minutes after they have worn out, are also of this material. Both the large rings and the larger of the two driving pulleys are made up of separate beveled circular pieces. A smaller ring with external grooves is used for the reverse. The bearings of the motor are large and are lubricated by grease cups. The cranks and pistons are lubricated by the feeding of oil with the gasoline, which system was introduced last summer by Mr. Duryea. The forward end of the triangular frame containing the motor is connected with the steering post, so that when the front wheels are turned in one direction or the other, the motor is moved slightly sideways and the friction upon the innermost driving-wheel ring is reduced, thus allowing the pulley to slip with the difference of speed occurs in turning a corner. The flywheel, F, is fitted with notches into

which a lug on the starting spring, S, slips. A cord on the front end of this spring runs forward and over a pulley up through the floor. By pulling the handle on the end of the cord the motor can be turned over and started from the seat. A starting crank can also be used on one end of the motor shaft extension if desired. The two-cycle motor is by all odds the simplest and most reliable type, and when this is made air-cooled (as it is in this case by means of special copper heat-radiating flanges of great conductivity

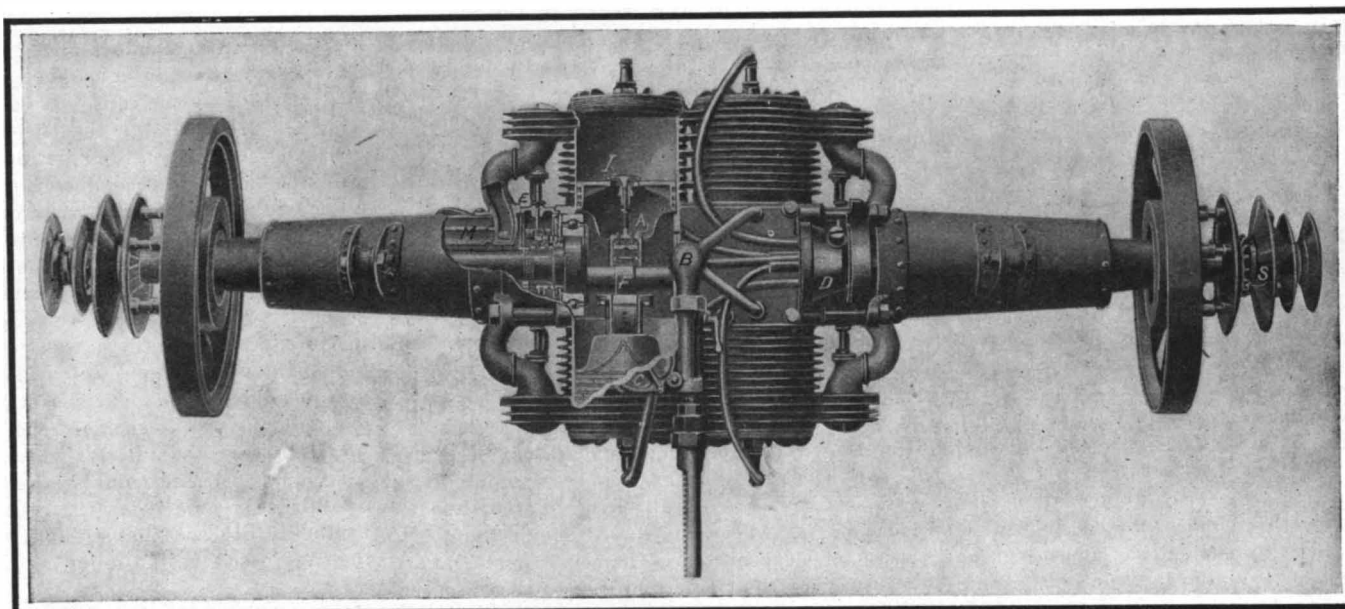

The twin opposed-cylinder engine and driving mechanism of the Holsman motor buggy.

The motor has novel features such as eccentric disks, F, on its shaft instead of cranks; inlet valves, I, in the pistons; and exhaust valves, E, operated by special grooved cams without gears. The pistons are connected together by a rigid frame and the eccentric disk works in a slot in same in a roller bearing, A. C is the carbureter and B the manifold connecting it to the crank case, into which the charge is drawn. The exhaust passes through the exhaust valves into mufflers, M, surrounding the extensions of the motor shaft. D is the distributor from which the wires run to the spark plugs. The power plant is hung upon two rollers. Note the expansible pulley with sprocket, S, for the low speed.

ity), and fitted with the simple lubricating arrangements that are used on such motors of the marine type, an engine of long life and simplicity and excellent wearing qualities is produced.

Another machine which resembles an ordinary automobile closely as far as the power plant is concerned is the "Simplo." This machine has a double-opposed-cylinder motor mounted in front under a bonnet. The motor is either of the air-cooled or water-cooled type. The longitudinal driving shaft, *S*, (see illustration) extends back from the motor to the middle of the frame

Tires (8 at \$8 each, requiring one hour to put on)....	\$2.00
Storage (machine kept in garage first year).....	4.50
Oil	1.72
Gasoline	6.11
New parts (cables \$15, chains \$24.50, coil \$42, sheaves \$11.20, batteries \$10, spark plugs \$12, muffler, \$6.75)	3.79
Overhauling (including painting once in 32 months)....	9.00
Labor	9.19
Substitute vehicle during repairs.....	2.00
	\$38.31

The machine referred to traveled an average of 20 miles a day and gave its owner satisfaction. The total cost of \$0.06 a mile for the 20,000 miles it has been operated is about one-quarter the cost of

Analysis of Honey.

C. A. Browne has published the results of an exhaustive research into the composition of specimens of American honey, with special reference to the influences exerted by the nectars of various flowers and by local conditions. Browne also formulates general rules for the variations in the composition of honey, which will be very serviceable to chemists engaged in the inspection of foodstuffs, and suggests valuable tests and improvements of official methods of analysis. In addition a number of problems of the chemistry of

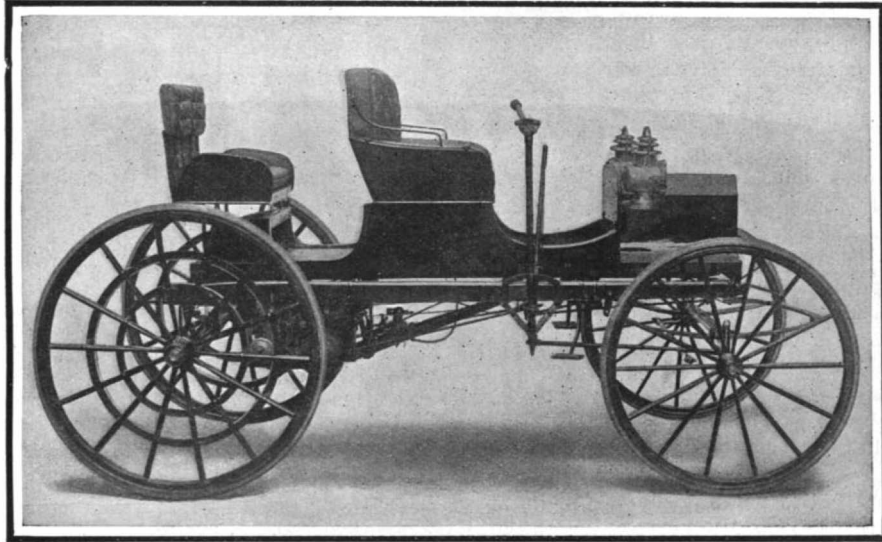

Duryea "Buggyaut" with extra foldable seat in the rear.

The simple friction drive direct from the pulleys on the ends of the motor crankshaft to the rings on the rear wheels is apparent in this photograph. The steering is done by a lever and the motor is throttled by twisting the steering handle.



The McIntyre motor buggy—a typical machine of this kind.

This machine has a 10-11-horse-power, $3\frac{1}{2} \times 3\frac{1}{2}$ double-opposed-cylinder motor, planetary transmission, and double side chain drive from a countershaft. A regular automobile steering wheel is used.

and carries on its end a cone, *C*, of impregnated fiber, which is mounted to slide upon it. On a transverse countershaft there are slidably mounted two beveled disks, *FG* and *RG*. One of these disks, *RG*, is used for the reverse, while the other one, *FG*, gives the forward speeds. As the cone *C* is moved forward by means of a hand lever, the beveled disk *FG* is slid upon its shaft so that it is kept in close proximity to the cone. Contact is obtained by pushing the two together by means of a pedal, whereupon *C* drives *FG*, which in turn drives the live rear axle through its shaft by means of a single chain. As the driven disks are of metal and the driver *C* of paper, any wear caused by slipping does not wear uneven places upon the paper pulley, as generally happens when this is the driven member, which it usually is in most friction-disk transmissions. The principal point about the cone-and-beveled-disk transmission is that the entire friction surface of the two members is in good rolling contact and that there is no difference in speed between the two edges of the driven disk, with the consequent slippage that necessarily occurs with the usual type of flat friction-disk transmission.

To give some idea of the cost of maintaining and operating an automobile of the high-wheeled, buggy type, we append some figures obtained from a physician in a New England city, who has used one of them constantly for the past three years. The machine was in almost constant use about town and long trips were occasionally made with it into the country over roads that were none too good. The average cost per month for a period of 32 months was \$38.31, which was distributed as follows:

running a pneumatic-tired automobile; and this could doubtless be considerably reduced in many instances.

In addition to the runabouts illustrated herewith, most manufacturers now make surreys and other forms of four-passenger rigs upon the same general lines. They have also entered the commercial vehicle field, and delivery wagons that can be quickly converted into passenger vehicles after they have been used for business are now on the market. The farmers of the middle West are rapidly coming to appreciate the advantages of this type of machine, and many of them are using it in place of horses. Such a convertible rig can be used to haul produce to market, and afterward to give the family a ride at the end of the day's work. It will traverse bad roads and is very serviceable.

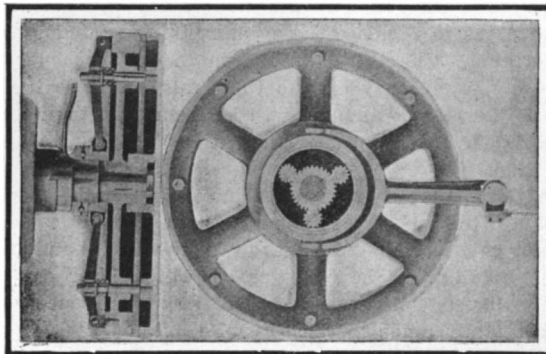

Disk transmission of the Schacht motor buggy.

The large wheel with the differential gear in its hub is slid over the face of the disk attached to the flywheel in order to obtain the different speeds.

honey are discussed, including the relations between honey and honey dew, gums, and other vegetable secretions, and the effect of artificial feeding of bees on the composition of the honey produced by them. The composition of honey dew, and floral nectars, and the methods by which they are transformed, "inverted" and preserved by the bees are described, and analyses are given of 100 specimens of honey, produced from 50 varieties of flowers in 32 States. The investigation includes both optical methods (direct polarization, polarization by inversion, estimation of levulose by Wiley's process) and chemical methods (determination of water, sugar, reducing sugar, ash, dextrine, free acid). The article also gives data concerning the adulteration of honey with cane sugar, invert sugar, and syrup made from starch, and methods of detecting such adulteration.

Death of Major E. L. G. Zalinski.

Major Edmund Louis Gray Zalinski, well known as the inventor of the dynamite gun which bears his name, and which was installed upon the "Vesuvius," died on March 11th in New York city. Major Zalinski was born in Kurnich, Prussian Poland, on December 13th, 1849, and came to this country when he was four years of age. During the civil war he served as an aide to Gen. Nelson A. Miles, and later entered the regular army. Between 1883 and 1889 Major Zalinski became widely known as an inventor of military devices and as an investigator of explosives. He was best known for his development of the pneumatic dynamite torpedo gun, which however never attained the widespread use that he hoped.

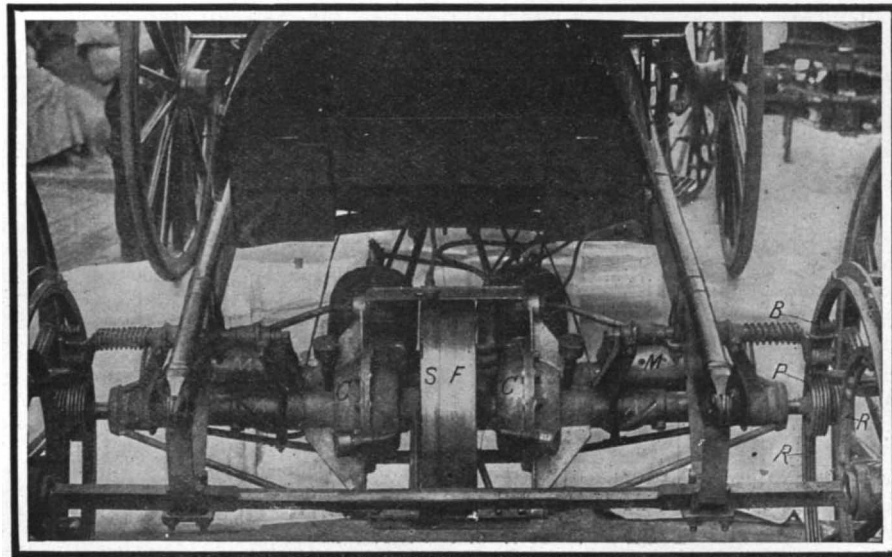

The power plant and driving mechanism of the Duryea "Buggyaut."

The two-cylinder air-cooled two-cycle motor has slidable extensions of its crankshaft carrying on their ends large and small grooved pulleys, *P*, which friction against the large grooved rings, *RF*, for the forward and reverse motion. *B* is the brake shoe. The crank cases of the motors are shown at *CC*; *F* is the flywheel between the two; and *S* the starting strap for starting the motor from the seat. The mufflers are shown at *MM*. *AA* indicate the spiral grooves in the crankshaft casing which, when the casing is rocked, cause the shaft extensions to move sideways and bring the small or large pulley opposite the ring for low or high speed.

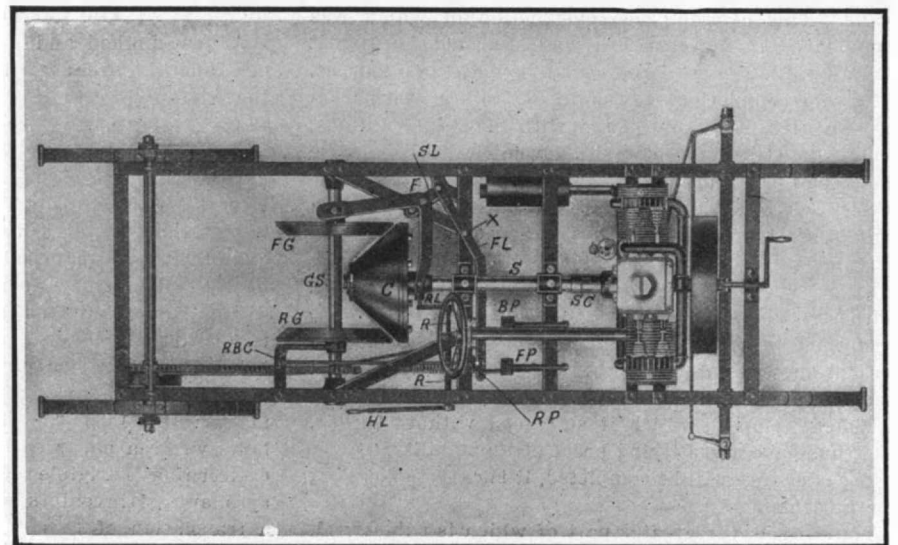

Plan view of chassis of "Simplo" runabout.

S, Extension of motor crankshaft carrying conical driving disk, *C*. *FG*, Beveled disk meshing with *C* for forward drive. *RG*, Reverse drive disk. *GS*, Countershaft. *HL*, Hand lever for operating disks and cone *C*. *FP*, Pedal for bringing disks and cone in contact. *BP*, Brake pedal. The cone and beveled disks, which are used in place of the usual flat disks shown above, have several distinct advantages which will be found described in the text. This car is different from most of its kind in that a live rear axle is used and also in the placing of the engine in front under a bonnet.

THE SCHNEIDER TORPEDO-LAUNCHING STATION.

The Schneider Company is completing a structure of a novel and unique character for the launching and regulation of the automobile torpedoes which it constructs for the French navy. The mechanism of these torpedoes is very intricate and delicate, including a four-cylinder motor, an auxiliary motor for steering, many pipes, valves, and cranks, and a system of gearing by which power is transmitted from the motor to the twin screws.

In addition, there is the ingenious regulating mechanism, including a clock, a hydrostatic piston, and a gyroscope, by which the vessel is held rigidly to the prescribed course and depth of immersion.

All of this machinery is contained in a hull 23 feet long, a large part of which is occupied by the compartment containing the compressed air by which the motors are driven.

It is easy to understand that the assembling of all these delicate organs is a difficult task. It is necessary to co-ordinate the movements of the various parts and to regulate their action until the torpedo can be relied on to pursue a perfectly straight course.

The regulation is effected by making infinitesimal changes in the positions and motions of the rudders, the clock, and the hydrostatic piston, the adjustment being determined half by theory, a quarter by practical experience, and the remaining fourth by trial and error. The regulation involves a number of launchings and trial trips, which must take place under certain favorable conditions. It is necessary, above all, to select a sheltered spot, where still water can be found even when the sea is rough, and where the torpedo can accomplish its full range, about 2½ miles, without risk of encountering vessels or other obstacles or a depth of water less than 50 feet. The trial ground must also be situated near a seaport and a railway, and it must have attached to it structures suitable for the preparation, regulation, and launching of torpedoes.

A site offering the conditions requisite for an establishment of this sort is not easily found. The company thoroughly searched the Atlantic and Mediterranean coasts of France before it found a suitable location, in the fine roadstead that extends between the Hyères islands and the Mediterranean shore, near Toulon. Even this site has the defect that a depth of 50 feet is not found sufficiently near the shore to make it practicable to erect the required buildings on land. Torpedoes are usually adjusted to travel about 12 feet below the surface, but as they are launched from a considerable height they go much deeper at the first plunge and make several oscillations upward and downward before they become definitely established at their normal level. Hence it is necessary to have a considerable depth of water in order to avoid all danger of striking the bottom, and a depth of 50 feet is deemed requisite.

Under these conditions the company decided to construct, at the point where this depth is found, and whence the course extends seaward, nearly at right angles to the shore, an artificial island to support a building containing all the appliances required for regulating and launching torpedoes.

This ingenious project is now accomplished and the tourists and fishermen see a many-windowed building, resembling a commodious dwelling, rising 30 feet above the water and apparently resting on it, 800 feet from the shore. The building is made entirely of armored concrete. It was designed by the engineers of the Schneider and Hennebique firms, in collaboration, and constructed at the shipyard at La Seyne, 20 nautical miles distant from its present site. The lower part of the structure is a huge caisson with slightly inclined walls. This caisson, the construction of which was commenced in March, 1908, was launched in August like an ordinary vessel and remained afloat two months. After its completion it was towed to its destination by two tugs, very slowly and with many precautions, on a calm, still night, early in November. The emplacement had been prepared by divers, and a carefully leveled bed of stone, about 12 feet thick, had been laid on the sea bottom. The caisson was moored very exactly over this foundation and gradually sunk by admitting water into compartments designed for that purpose. These difficult and delicate operations were performed in exceptionally favorable weather and with perfect success. A few hours after the floating island had become a fixed one it was exposed to the fury of a violent tempest, which it sustained without injury, and thus gave a gratifying proof of its stability.

The structure will be completed, it is expected, during the present month.

The caisson, the greater part of which is submerged, terminates in a platform 11 feet above mean sea level. It is almost a solid mass of concrete, but contains a subaqueous water-tight chamber, in which are placed tubes for launching torpedoes under water. These tubes project through the wall of the chamber, and are fitted with water-tight joints. Their outer ends are surrounded by a lock, which, when closed and pumped dry, permits examination and repair of the tubes and their doors. At and above the water line, the caisson

is protected by wooden fenders from injury by vessels, torpedoes, and other floating objects.

A two-story building is erected upon the platform. The lower story contains tubes for launching torpedoes above the water level and is connected with the chamber beneath by a large opening in the floor. After each torpedo has finished its course it will be picked up by a vessel, brought back to the station, hoisted to the platform by tackle running on a concrete beam and received in a large recess in the first story, whence it will go to the regulating and repair room for further adjustment. All the hoisting, conveying, and other machinery, including a series of railways, a pump for emptying the subaqueous chamber, and air compressors for charging the torpedoes, will be operated by electricity furnished by two generators, driven by petroleum motors.

The upper story of the building will contain offices, lodgings for caretakers, and an observation room placed directly over the launching tubes, and supported on cantilevers outside the wall of the building. This room will have a bay window with a glass floor, so that the moment at which the torpedo leaves the tube can be noted, for the purpose of determining the velocity. The observation room will be surmounted by a signal tower from which communication can be held with observers stationed on floats at various points of the course.

The Amateur Wireless Operator.

Some time ago, when the fleet was on its last lap of the famous around-the-world trip, trouble was experienced by the operators of several naval wireless shore stations scattered along the Atlantic coast. Complete messages could not be received by these stations, because amateur wireless operators would interfere. Their periodicity was nearly the same as that of the ships of the fleet, that is, 425 meters wave length, and many of them have as strong a sending apparatus as the ships.

Take Washington, D. C., for instance. There are at least fifty well-equipped stations. Their operators range from twelve to fifty years of age. They may not be able to send as far as the naval station, but when it comes to receiving, they get everything that is in the ether. Many of them at times hear distant stations calling the navy yard, and when no answer is heard, these young operators then call the naval station, and report that a distant station is calling them. It is claimed that the operators on watch never respond to these favors, and go on with their regular business. It certainly seems as though the naval operators were not appreciative.

Complaints are sent in every day at the Navy Department. If this continued interference keeps up, the wireless amateurs will get themselves into trouble. Two plans to regulate these youngsters are under consideration. One is to limit them to certain hours of the day, when they can do their talking. The hours most likely to be adopted will be from 3:30 to 7. Another plan is to license these stations, as they do over in England.

About a year or so ago, a high school student, who had a wireless station, thought he would have some fun by sending fake messages to the navy yard and sign the "Dolphin." The operator on watch later caught the guilty offender. A report of this occurrence was immediately made to the Navy Department, which referred the matter to the District Attorney. It was found that nothing could be done with the young man, who promised to "be good" when it was explained just what damage his mischievous pranks with wireless might do.

The Current Supplement.

A new method and a machine for degreasing wool continuously are described in the opening article of the current SUPPLEMENT, No. 1733. Dr. Robert Grimshaw exposes some wire-nail fallacies. Prof. Reginald Fessenden's paper on Wireless Telephony is continued. John S. Fielding writes on "Safety Factors in Dams." San Francisco's new fire-protection system is exhaustively described. Brimming with many a quaint bit of historical information is Franz Feldhaus's "Submarine Experiments of the Past." A. E. H. Tutton contributes an excellent paper on the Crystallization of Water. In a paper entitled "The Untilled Field of Chemistry" Arthur D. Little dwells on the stupendous stores of potential energy bound up in matter. In 1885 the distinguished physicist Helmholtz wrote a paper entitled "Theoretical Speculations Concerning Dirigible Balloons." For the benefit of aeronautical inventors we publish in the SUPPLEMENT a translation of this paper.

Magnesium is now being employed to some extent as a deoxidizer in brass manufacture, having the advantage over phosphorus that an excess may be used without harm, and, indeed, may improve the quality of the brass. Magnesium is a metal which belongs to the same family as zinc. Ordinarily the addition of 0.05 per cent of magnesium to the brass is sufficient for deoxidizing purposes.

Correspondence.**GENERAL FORMULA FOR COMBINATIONS OF NUMBERS.**

To the Editor of the SCIENTIFIC AMERICAN:

I was much interested in Dr. J. G. Bland's letter in the issue of February 13th, as I had made some researches in a similar direction. I was seeking combinations of numbers that would bring any finite results in problems illustrating Euclid's proposition No. 47, Book I.

In the (Boston) Journal of Education of September 5th, 1907, and April 2nd, 1908, appeared communications from me bearing on this.

I would now submit an equation in harmony with which must be all problems, which secure finite results, illustrating this proposition:

$$(ln)^2 + \left[l \left(\frac{n^2}{2m} - \frac{m}{2} \right) \right]^2 = \left[l \left(\frac{n^2}{2m} + \frac{m}{2} \right) \right]^2$$

FRANK JEROME, SR.

Boston, Mass.

ACCURACY IN SCIENTIFIC DICTION.

To the Editor of the SCIENTIFIC AMERICAN:

Prof. S. A. Mitchell's article in the SCIENTIFIC AMERICAN of February 6th contains a number of inaccuracies that should not pass unnoticed.

First, the extremely loose way in which the terms "temperature" and "heat quantity" are used is to be deprecated. It should be remembered that the thermometer measures temperatures, and that such terms as "degrees of heat" have no meaning.

In explaining the action of the thermopile Prof. Mitchell says: "When heat strikes a thermopile it alters the resistance offered to an electrical current passing through it, and this change of resistance is measured by the galvanometer." The most elementary text-book shows that the action of the thermopile is nothing of the sort.

Further on we find: "Where the strength of the solar heat is the large number 10,000,000 that of the moon (i. e., reflected solar radiation) is only 12; or in other words the sun shines with an intensity 800,000 times that of the moon." It would be pleasing to learn what justification there may be for the term "strength" as applied to solar heat. This sentence, however, commits the graver fault of treating two distinct propositions as identical. It may be that the sun shines with an intensity 800,000 times that of the moon, the comparison being made with the photometer, but when the total radiations of the two bodies are compared the ratio is about 180,000 to 1, and the latter is the ratio here involved, as nearly as I can make out.

What is meant by the "intensity of the corona at 1.5 millimeters from the sun's limb," etc.? We may guess that Prof. Mitchell means the rate of radiation of the corona at the above-mentioned distance from the edge of the solar image (size not specified) given by his particular apparatus, but as the language stands it really means nothing at all. It is an extremely dangerous practice to use scientific terms in other than their exact and accepted signification.

C. C. HUTCHINS.

Bowdoin College, Brunswick, Me.

FROM THE TRACK-WALKER'S STANDPOINT.

To the Editor of the SCIENTIFIC AMERICAN:

The unveiling of disagreeable facts sometimes helps to needed reforms. In a late editorial you bore down heavily on the antiquated railroad spike as out of place in the modern American roadbed and track, and only fit for a museum of railroad antiquities; at the same time commending the general excellence of the best modern American roadbed and track.

I venture the assertion that there is as little of such bed and track in proportion to the whole as there is of the best American highway.

The locomotive is said to be the most perfect and useful or satisfactory machine that man has made, and the ordinary wheeled vehicle, to say nothing of the automobile, has also reached a high state of perfection. Yet they both run upon roads that in general are full of defects.

In all the controversy between the railroads and the railmakers over the weakness and imperfections of the rail, the railmen have always acted upon the defensive, whereas they might well, and with perfect safety, have carried the war into the camp of the enemy. Rails are sometimes defective, it is true, but the treatment they receive, and the abnormal strains to which they are subjected and in the main endure without injury, entitle them to be called one of the very best products of the American manufacturer.

The rail as delivered to the consumer is a straight piece of steel, and is intended to lie flat, with more or less rigid connections, upon a comparatively unyielding surface. It is actually placed upon a bed almost as yielding in proportion as the packed soil of the ordinary highway yields to the carriage wheel. In most cases it very soon assumes a bent condition, usually lowest at the joints, and in many cases very much depressed, so that in looking along the line from a little above its level, it seems to be made up of arcs of circles. These are short in perspective, and so they are in the rapid transit of heavy wheels over them, making the shock of impact very abrupt. Moreover, they do not lie still, but a wave of depression passes along them as the wheel advances. In a short time, as you say, the vertical motion has loosened the spikes, and the depression at the joints increases. How hard it is to make a level joint appears from the fact that on many bridges and trestles where the foundation is timber and not soil, this joint depression is plainly to be seen.

In the electric traction experiments at Berlin, it was found that high speed was so destructive to the track, that an entirely new system of road building had to be devised. It may come to this for the use of our fast and heavy locomotives before safety can be assured. The imperfections mentioned would seldom be noted by the unpractised eye from the level of the car, but from the level of the trucks they are only too apparent.

I have repeatedly watched the great depression at the rail joints from the passing of locomotives on good track and away from stations. In one instance, five heavy mountain engines coupled together passed me between stations on a road accounted one of the best. The rails not only bent deeply at the joints, but the ties away from the joints seemed to move freely up and down in the ballast. The ballasting, though apparently of the best, was too coarse, so that it did not hug the ties, and a large proportion of the spikes did not bind the rails to the ties. Though the curves were short here, and the grades heavy, there was no lateral bracing of the rails to insure their standing up, and I was told that accidents on this part of the line were of frequent occurrence. And here was in use a heavy, wide, tie plate, which practically covered the full width of the ties, whereas the ordinary tie plate, as I have seen it, is so narrow as to afford but little more bearing than the rail itself. Section men say that the short life of the tie is owing not so much to decay as to the cutting occasioned by the pounding of the wheels. How necessary, then, to employ a tie plate with a wide bearing on the tie.

On at least one great transcontinental line, the tie plate, so essential in preventing lateral movement also, is conspicuous by its absence; and this line boasts some of the heaviest locomotives in use. I noted also along this line piles of ties just removed and awaiting the torch, which seemed to be but masses of splinters and decay, so long had they been kept in the ground.

On another line I saw one place where the shattered ties, four or five together, afforded but little support for six or eight feet of rail. And no doubt it is in such places as this that the rails spread, as certainly there is little to hinder. One fast train which I failed to catch, I was later interested in learning, was ditched while running at good speed on straight track, by spreading rails.

No doubt individual pieces of track show care, or the want of it, on the part of the section boss, but the lack of tie plates, and of lateral bracing on curves, indicate a defective system.

I saw two rails, opposites, in which only two spikes at each end of the rail were driven home, the section men evidently having been called off to other work. All the rest were started only, and stood from one to three or four inches above the rail base. This condition lasted for forty-eight hours on a main line where there was an average of a train an hour, many of them fast and heavy express trains. It was invitation to disaster, and yet had a derailment and wreck occurred, who even of the officials would have suspected the cause?

On one electric line I watched for many miles a new curve. The usual joint depression was marked, but in addition the rails were spread at the joints, where they were highly polished by the pounding of the wheels, while on the apex of the curve the wear showed only on the inner half of the rail face. While high speed was made on this road, its roughness appeared from the fact that it was difficult to keep one's seat without bracing the feet. The rails were comparatively light, and more readily responsive to the inequalities of the roadbed.

I think these observations go to show, not only the remarkable endurance of the American rail, but the need of a better bed for it to lie on, not only for its own life, but for that of the traveler.

Chicago, Ill.

GEORGE S. PAINE.

THE LOCUST TREE: AN IMPORTANT FIELD FOR INVESTIGATION.

To the Editor of the SCIENTIFIC AMERICAN:

The locust is one of the most valuable trees growing in the United States. In common speech we have the black, yellow, and honey locust. The botanists recognize the false acacia, or *Robinia pseudacacia*, and the *R. hispida*. The wood has a strength as great as or greater than any of our native woods. Its only rival in common use is the hickory. The latter, however, is not nearly as strong. Hickory has the one advantage of being much more elastic. The locust resists crushing in experiment to the extent of 9,800 pounds, and its tensile strength is put at 18,000 pounds per square inch. The wood is almost insensible to decay, and lasts under water like white pine, which is in that position indestructible. Its great tensile strength and durability caused its universal use for treenails in wooden ships. No other wood ever took its place for this purpose.

The insensibility of the wood to decay appears to be due to some form of pitch or waterproof varnish within the wood. It seems to the casual observer that there was some chemical combination with the cellulose itself, which rendered it immune from the action of water. Even a locust post seems perfectly indifferent to decay at the surface of the ground.

Since the cellulose of the locust seems not to be different from that of other trees, the importance of a chemical investigation, which shall discover the secret of its remarkable and valuable characteristics, can at once be seen. The discovery of some means of converting ordinary cellulose into a compound having the same properties as that of the locust would be simply invaluable in the arts. If merely a method of imparting its waterproof qualities to the cellulose of the spruce, for example, could be discovered, it would result in the creation of a new and gigantic industry, perhaps several.

An investigation of this subject opens a wide field to the young man. Its importance and value can hardly be overestimated.

It will be interesting to note the fact that the finest, strongest, and most desirable locust timber in the United States is said to be found on Long Island. It is also said that the tree grows more rapidly there than anywhere in the country. From the so-called annual rings, it appears to be one of our most rapidly-growing trees. Owing to the extreme hardness of the timber, it does not promise to be a favorite with lumbermen. It is somewhat surprising that the locust is not more frequently recommended for railroad plantations.

B.

WHAT IS THE SELDEN PATENT?

BY CHARLES B. HAYWOOD.

Although manufacturers' organizations, formed as the result of differences of opinion concerning its validity, have done a great deal to spread knowledge concerning it and have greatly emphasized its importance, much confusion exists in the public mind as to just what the so-called Selden patent is. Exactly what its claims cover is something of which even the majority of well-informed motorists have but the haziest conception. Probably the one thing that is generally known regarding what bids fair to make for itself a niche in American patent history, as lasting as that of the Bell telephone, or McCormick reaper litigation, is that there are a certain number of manufacturers who acknowledge the validity of the Selden patent and pay royalties under license; likewise that there are others who refuse to part with even the small percentage of their profits now demanded as tribute. Originally the royalty paid by the licensees to the owners of the patent was 1.25 per cent. A reduction to 1 per cent was afterward made by the owners of the patent, voluntarily, as the volume of business increased. Subsequently, owing to the refusal of several of the licensees to pay the royalties at the old rate to the receivers of the Electrical Vehicle Company, the owners of the patent, a petition, filed by the licensees, was granted by the Federal Court for a reduction in the amount of royalty from 1 per cent to 0.8 of 1 per cent.

It is also generally known that the two trade organizations in question have been formed for the mutual protection of the interests of their members; one to uphold the Selden patent, hold automobile shows, and generally advance the welfare of its supporters by various means, such as the maintenance of a laboratory, an engineers' department holding monthly meetings, and the like; the other to fight the patent, its objects otherwise being the same as the first, though it has not developed them to the same extent as yet. These are respectively the Association of Licensed Automobile Manufacturers and the American Motor Car Manufacturers' Association, generally known as the Licensed Association and the Independents. Each holds an automobile show in New York annually. In Chicago, they sink their differences for the time and exhibit together simultaneously. This serves to sum up the extent of general knowledge on the subject. It may be added here that there are other manufacturers, of no small importance, who acknowledge the standing of neither association by holding aloof from both. Needless to add, they pay no royalties.

The Selden patent was granted to George B. Selden, of Rochester, N. Y., November 5th, 1895, and is known in the United States Patent Office files as No. 549,160. The application for patent rights was filed sixteen years earlier, or on May 8th, 1879. The subject of the patent is set forth by the applicant as an "Improved Road Engine," while its chief advantages are stated as "the elimination of the great weight of the boiler, engine, water, water tanks, the complicated apparatus necessary to adapt the machine to the roughness of the roads which it must traverse, the necessity of a skilled engineer to prevent accidents, and the unsightly appearance of locomotives built on this plan."

Parts of the specifications upon which the inventor and the Licensed Association found their appeals to the courts to sustain the basic nature of the Selden patent, are as follows: "I have succeeded in overcoming these difficulties by the construction of a road locomotive propelled by a liquid hydrocarbon engine of the compression type, of a design which permits it to be operated in connection with the running gear . . . very largely reducing the weight of the machine in proportion to the power produced, and which enable me, while employing a most condensed form of fuel, to produce a power road wagon, which differs but little in appearance from, and is not materially heavier than the carriages in common use, is capable of being managed by persons of ordinary skill at a minimum of trouble and expense, and which possesses sufficient power to overcome any ordinary inclination. Any form of liquid hydrocarbon engine of the compression type may be employed in my improved road locomotive. As the general mode of construction and operation of liquid hydrocarbon engines of this class are now well known, it is considered unnecessary to further describe them here.

"The traction wheels are attached to the axle by clutches, splined on the driving shaft and held in mesh by springs in order to permit of the wheels rotating independently of each other to facilitate progress over rough roads and the turning of corners. These clutches may also be used for the purpose of disconnecting the engines from the traction wheels. Friction or ball clutches may be used for this purpose. Provision is made for backing my improved road engine by reversing the motion of the driving wheels by a set of reversing gears . . . a clutch is interposed between the engine and the driving wheels so as to admit of running the engine while the carriage is stationary."

Selden accordingly made the following claim:

"The combination with a road locomotive, pro-

vided with suitable running gear, including a propelling wheel and steering mechanism, of a liquid hydrocarbon gas engine of the compression type, comprising one or more cylinders, a suitable liquid fuel receptacle, a power shaft connected with and arranged to run faster than the propelling wheel, an intermediate clutch or disconnecting device, and a suitable carriage body adapted to the conveyance of persons or goods, substantially as described."

It will be apparent from this that the patent granted to Selden accordingly covers every one of the fundamental essentials of the gasoline automobile of the present day—the internal-combustion motor working on a compression cycle, a clutch or means of disconnecting the road wheels from the engine, the latter being designed to run much faster than the road wheels, and a means of reversing by a gear train. The differential principle of driving the wheels was also involved, but this has no bearing on the patent. Evidently, if Selden's claims can be substantiated, they are basic, and enormous royalties may be collected. It all hinges upon whether or not Selden was anticipated by other investigators in the same field, or as the legal phraseology of the Patent Office has it, whether there is anything in the "prior art," which would render his claims to originality entirely unfounded.

Apparently, this is rather a simple question and it has been settled times without number, both *pro* and *con*, by automobile enthusiasts, who are willing to pass unequivocal judgment in accordance with their own views without the slightest hesitation. Thus far, however, it has consumed nine years of litigation, almost half a million dollars, and 60,000 folios of testimony to provide the courts with something upon which to base a decision, and this has yet to be rendered. The life of the Selden patent comes to an end, November 5th, 1912, and there is at least a doubt as to whether the question of its validity will be finally settled before it legally expires. It has been considered in automobile circles that this is somewhat of an exceptionally long-drawn-out instance of patent litigation, but the telephone, reaper and binder, and the sewing machine furnish parallel cases that greatly exceed it, these landmarks in our patent history having been in the courts throughout practically the entire terms of their legal existence of seventeen years.

As early as 1899, George Day, then president of the Electric Vehicle Company, became convinced of the value of the Selden claims, and his company accordingly acquired a controlling interest in the patent. The company in question, which is now operating in the hands of a receiver, was then making gasoline as well as electric vehicles, and in 1900 it undertook the task of enforcing its right by bringing an action against the Buffalo Gasoline Motor Company, and the Automobile Fore Carriage Company (it was always Selden's idea to drive the forward wheels) as infringers. Half a year later, another action was instituted against the Winton Motor Carriage Company, which was one of the first concerns in this country to market gasoline-driven vehicles on any scale. About two and a half years then passed without any developments of note, and then George Day, having resigned as an official of the Electric Vehicle Company, undertook the organization of the Association of Licensed Automobile Manufacturers. It was on March 10th, 1903, that the association came into existence with ten American manufacturers of automobiles as charter members. The litigation against the Buffalo and Winton concerns was then amicably terminated by the defendants agreeing to become members of the association and to pay royalties. A number of minor actions in the shape of petitions to the federal courts to enjoin the use of imported vehicles were brought against individuals and importing companies about the same time, with varying results. One or two were allowed to go by default through the defendant's failure to appear and contest the case, and injunctions obtained under such circumstances were exploited as evidence of the validity of the patent, Judge Hough of the United States Circuit Court for the Southern District of New York, denying an application to punish for contempt of court the violation of one of the injunctions obtained by default, stating emphatically that the patent could not be established by injunction. As a whole, the result of these actions was not any great gain or loss to either side.

About six months after the actions against the first infringers to be proceeded against had been ended by their capitulation, the Ford Motor Company was organized in Detroit. One of the most important clauses in the articles of agreement of the Association of Licensed Automobile Manufacturers is to the effect that only firms which were actually engaged in the manufacture of automobiles on or before the date of its organization (it is not an incorporated body) were eligible to membership, and as the industry was hardly in its first swaddling clothes in the early part of 1903, it will be apparent that many important companies entering the field later were barred, willy-nilly. A notable instance of this was found in the organization of the Selden Motor Car Company in 1907, the inventor being com-

pelled to acquire an outstanding license under his own patent before he would be permitted to manufacture automobiles. This was accomplished by the acquirement of the license of the Buffalo Gasoline Motor Company, which relinquished its membership and gave up the manufacture of automobile motors, devoting its efforts entirely to the building of marine motors. As the number of licenses in the market was governed entirely by the failure or retirement of existing concerns, it will be evident that there was no alternative to companies starting at a later date, than to cast their lot with the Independents, whether they actually joined that organization or not. The American Motor Car Manufacturers' Association did not come into existence for some time afterward (February, 1905), and, due to poor management, did not make its influence felt at first.

Whether it had been possible to obtain a license or not would not have influenced Henry Ford, as he was determined to fight the Selden claims and has done so steadily for the past six years. From the very first, the action of the Electric Vehicle Company vs. the Ford Motor Company developed into a test case. During that period no stone has been left unturned to procure evidence of inventions antedating Selden. It is said that the claim of the combination of a hydrocarbon motor with a running gear and a device for disconnecting the engine from the running wheels is not tenable as such, whether as a basic claim or otherwise, and the upholders of the patent have accordingly founded their appeals to validity upon limitations concerning the type of engine to be employed. To prove these contentions, expert witnesses have been brought from abroad, a notable instance being that of Dugald Clerk, the well-known English authority on the internal-combustion motor, who spent several months here giving testimony for the owners of the patent. Every possible record having the slightest bearing upon the matter during the past century has been investigated, and in this way a mass of testimony, the taking of which was only concluded a month or so ago, has been accumulated.

Considerable misconception exists as to the vehicles which have been built under the Selden patent, one of

the chief contentions of the defendants in the test case being that a vehicle built to conform to the patent specifications would be utterly impracticable. The car shown in the accompanying photograph and bearing the date 1877 will be seen to resemble the vehicle of

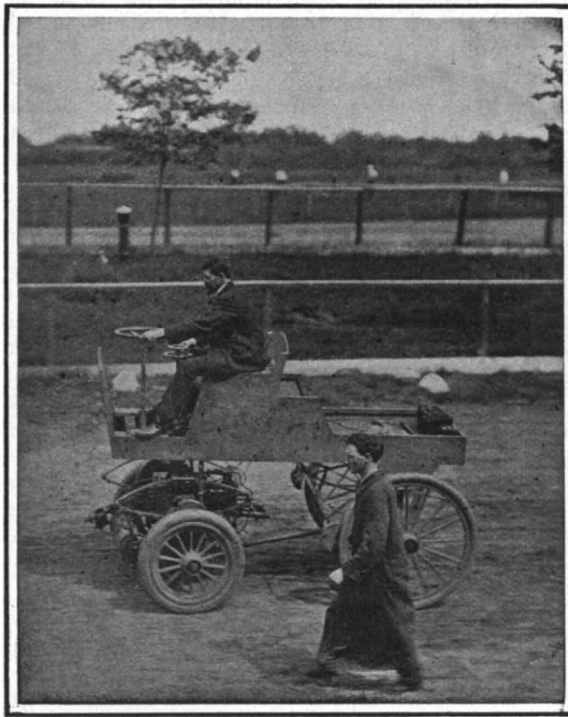

"Hartford" Selden car built in 1905.

Note the control wheel. The exhaust is ahead of the car.

the patent drawings, though, as a matter of fact, it did not come into existence until the latter part of 1905, or the early part of 1906, and it is claimed to differ materially from the original specifications in that electric ignition has been substituted for the original device described. What is known as the "Hartford" car, which was built a little earlier than the

"1877" model by the Electric Vehicle Company at Hartford, is also shown by the photographs. In this engine the nature of the cycle differs materially from that of the patent, the motor being of the constant-pressure type, and also having electric ignition. It was tried out at the old Guttenberg track a few years ago, but it did not make as good a showing as the other car has in its various trials upon the New York streets, some of these events being illustrated by the accompanying photographs.

In the course of hunting up old records, an unusual number of instances that the respondents in the test case claim to antedate Selden have been found. Some of these go back as far as 1828, and it would require a volume of no mean dimensions simply to attempt to catalogue them all. The actual application of the automobile has really come about within a very few years, but it will be apparent from this that it is the development of a great many years of experimenting. Some of those cited as having antedated Selden in more ways than one, are Becquar, 1828; Lenoir, 1861; Carré, 1865; Menn, 1877, and a great number of others on the Continent. In this country, Brayton actually applied one of his constant-pressure type of gas engines to a street car in 1873, and to an omnibus five years later, though in neither case did these applications come into commercial use.

All this testimony is naturally merely supplementary to the contentions of the respondents that the machines built a few years ago by the upholders of the patent, in order to show that the latter was workable, are in reality not in conformity with the specifications of the patent, and that a machine built strictly in accordance with what it sets forth would be utterly impracticable. Both of the motors built to serve as exhibits in the case work on what is technically known as the two-part cycle, or more generally as the two-cycle, in that the cylinder fires a charge once in every revolution. The patent drawings show a type of engine having a differential piston, the small end acting as an air pump and maintaining pressure in a special air tank, while the liquid fuel is sprayed into the air rushing into the cylinder through the inlet valve, a small oil pump being employed for this purpose. One of the

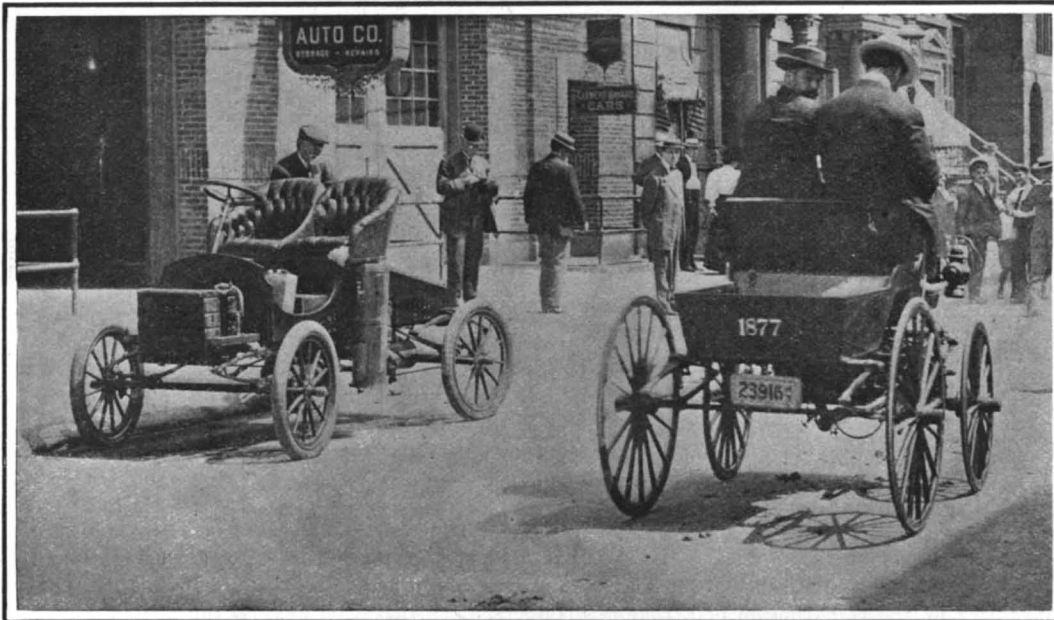

The "1877" Selden car built about 1905.

Standing at the curb is the car built by Henry Ford as an exhibit in the suit. It is equipped with a constant pressure engine and carbureter which was invented about 1865 and which is the large copper tank shown at the side.

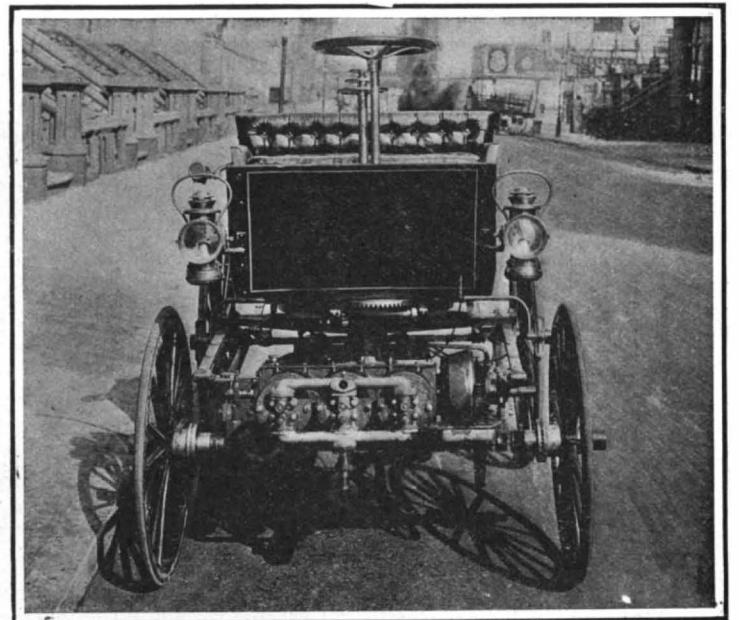

Front view of the "1877" Selden automobile.

The car has been built as nearly as possible to conform with the specifications of the Selden patent. The patent will expire in 1912.

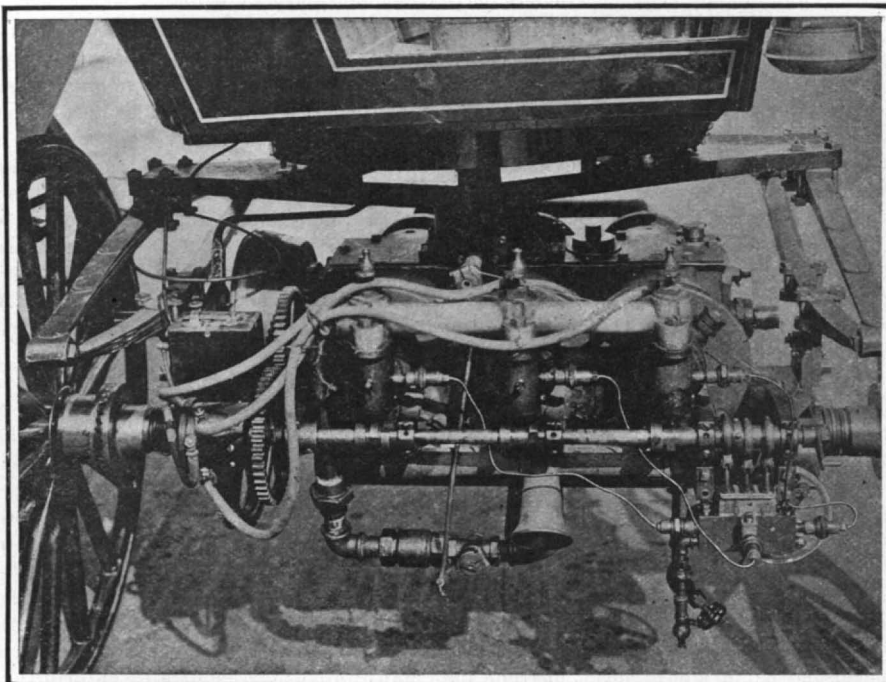

Oil pump for fuel feed at right. The bell mouth extending downward is the exhaust.

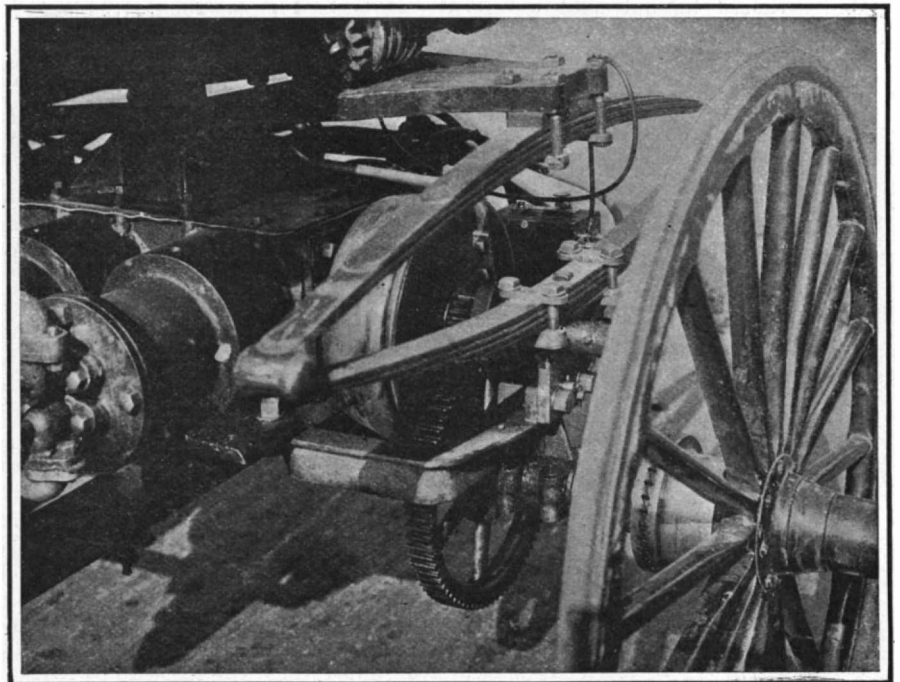

Friction clutch, reducing gears, and hub clutch.

AUTOMOBILES CONSTRUCTED ACCORDING TO THE SELDEN PATENT.

contentions of those who are trying to have the patent declared invalid is that such an arrangement of feeding air and fuel could never be practical on a vehicle, regardless of the smoothness of the roads.

To sum up, the situation with regard to the Selden patent at the present moment is about as follows: All the testimony to be presented by both of the litigants has been heard, the last having been taken early in January of the present year. This huge mass of matter,

to attempt to move the wire away, or drag the victim out of contact with it, but by taking a coat by the sleeves and twisting it into a rope, as shown in one of the illustrations, two men on either side of the wire may lift it safely with the improvised rope. This experiment was tried even with a damp coat, and high-tension conductors were lifted without the operators' feeling the slightest shock. In case of a victim falling across a live rail, he may be removed either by

rent line. These experiments then show that a fireman need have little fear of injury to himself when operating in the vicinity of high-tension circuits. The experiment of using salt water in the hose line was not tried. No doubt, as salt water is a far better conductor than fresh water, the firemen might have found it quite hazardous to use the hose so close to the high-tension wires. Chemical extinguishers were found to be very dangerous. A voltmeter was connected be-

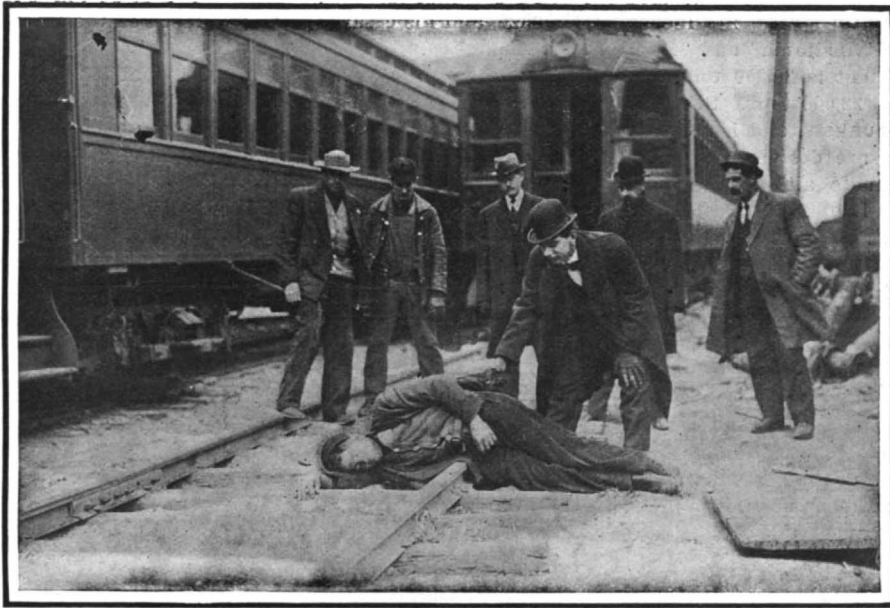

The safest way of dragging a man off a live rail.

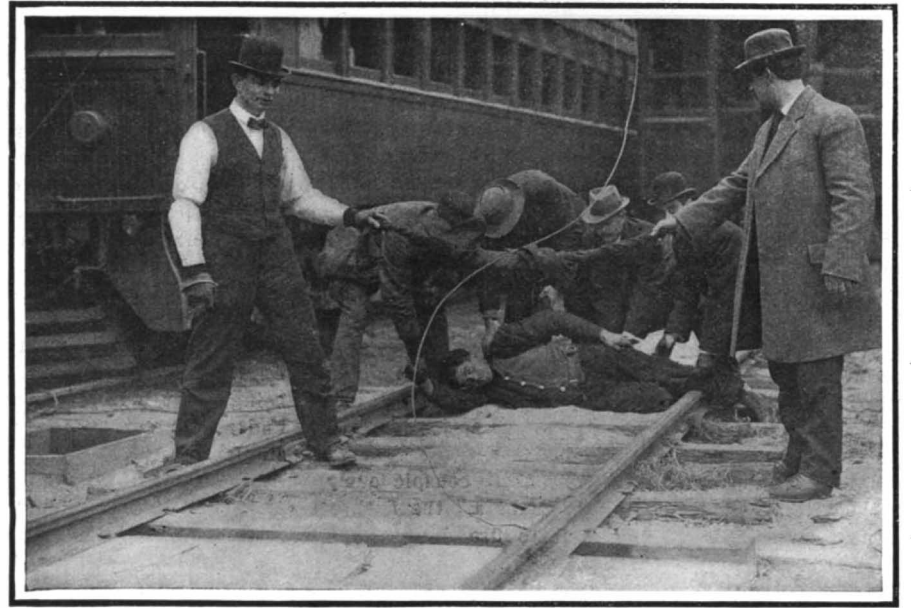

Using a coat as a rope to lift a live wire.

comprising many thousand typewritten folio sheets, will be printed as the record of the case, and if the thirty-odd cases that are on the Circuit Court calendar in New York for its spring sessions can be disposed of in time, the Selden case will come up for trial in May next, this consisting principally of an oral argument of the merits, *pro* and *con*, by counsel for each side. Regardless of which party the court's decision favors, it is a foregone conclusion that there will be an appeal. That will mean the lapse of about another year, before the matter again comes before the court, this time the Circuit Court of Appeals. Then some time will elapse before a decision is rendered, so that it will probably be 1911 before there is anything definite to record. A few of the customary delays will easily bring this up to the date of expiration in 1912.

FIRST AID TO THOSE INJURED BY ELECTRICITY.

The increasing use of electricity on our large railroad systems, and the danger it offers to employees, have aroused officials to the importance of instructing their men how to act in case of accident. It frequently happens that a man who receives a shock is allowed to suffer from lack of proper immediate treatment, owing to the inherent dread of electricity among all those who are not familiar with the handling of electric circuits. Again, the victim may receive a severe shock and may appear to be dead when he is

seizing the twisted end of his coat and dragging him off, or by using a wooden pole; as dry wood is a very good non-conductor.

At the meeting in Altoona, a new type of pliers was tried out, and found to be just the thing for cutting live wires. The pliers were provided with wooden handles, so that the hand did not come in contact with any of the metal parts. The handles were boiled in paraffine, rendering them such good insulators that they withstood a pressure of 8,000 volts. With these pliers a line carrying 2,300 volts was repeatedly cut by a man standing on the ground, without his experiencing any unpleasant shock.

A very interesting series of experiments was undertaken, to determine what measure of danger there would be to a fireman who was obliged to direct a stream of water against a live wire. For this purpose several circuits were provided, one a 525-volt direct-current circuit. One side of this circuit was grounded, and a 5/8-inch stream of water was played against the other side. A voltmeter placed between the hose nozzle and the ground showed a potential of 20 volts when the nozzle was held at a distance of 7 feet 5 inches from the wire. At 3 feet 7 1/2 inches the potential was 60 volts, and at 2 feet 2 inches 70 volts, while at 7 1/2 inches it amounted to 210 volts. This showed that the firemen need not fear to operate the hose at a distance of 3 or 4 feet from the wire, and if stand-

tween the ground and an extinguisher, and a stream from the latter played on a line carrying 2,500 volts. At a distance of 9 inches from the line, the voltmeter showed a reading of 1,500 volts. This is a very important matter to bring to the attention of the public, for the reason that passenger trains are usually equipped with chemical extinguishers, and in case of a wreck on an electrified line, serious consequences might result from the promiscuous use of these extinguishers.

Official Meteorological Summary, New York, N. Y., February, 1909.

Atmospheric pressure: Highest, 30.41; lowest, 29.24; mean, 29.95. Temperature: Highest, 58; date, 10th; lowest, 5; date, 1st; mean of warmest day, 47; date, 24th; coolest day, 12; date, 1st; mean of maximum for the month, 43.7; mean of minimum, 30.9; absolute mean, 37.3; normal, 30.7; excess compared with mean of 39 years, 6.6. Warmest mean temperature of February, 40, in 1890. Coldest mean, 23, in 1875 and 1885. Absolute maximum and minimum for this month for 39 years, 69 and -6. Average daily excess since January 1, 4.5. Precipitation: 4.31; greatest in 24 hours, 1.56; date, 23rd and 24th; average of this month for 39 years, 3.80. Excess, 0.51. Accumulated excess since January 1st, 0.08. Greatest February precipitation, 7.81, in 1893; least, 0.82, in 1895. Snowfall, 1.4. Wind:

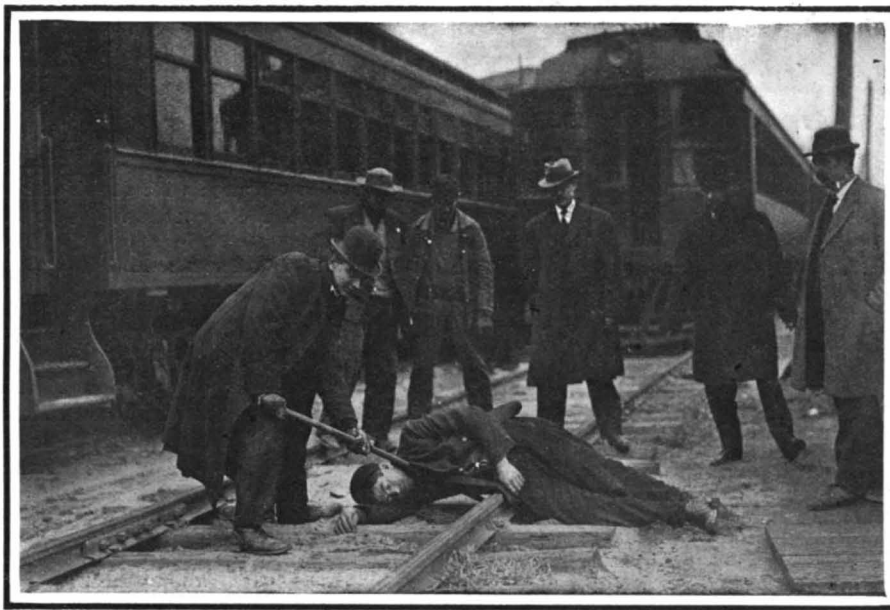

Prying a victim off a live rail with a wooden pole.

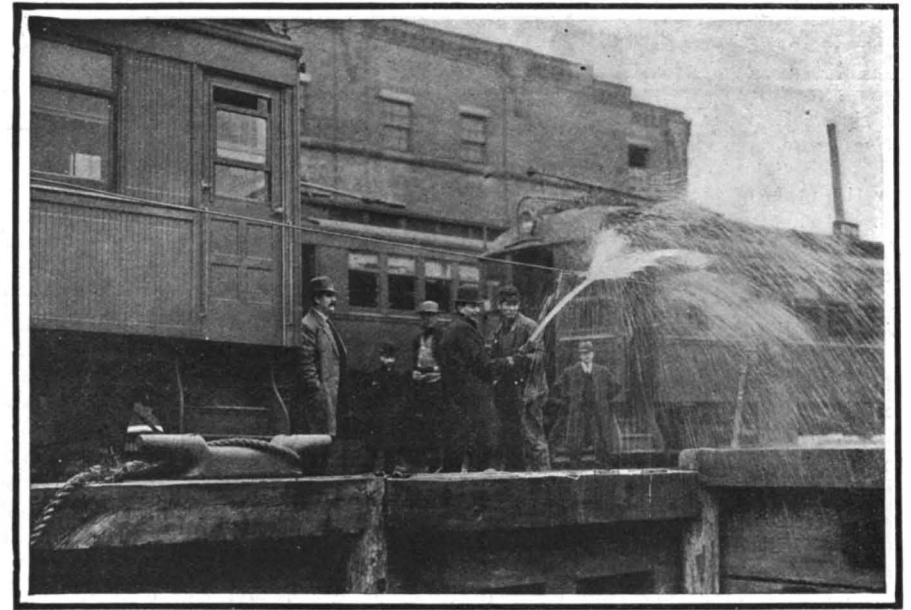

Playing the hose on a high-tension conductor.

FIRST AID TO THOSE INJURED BY ELECTRICITY.

only stunned, and if properly worked over he may be resuscitated.

Not long ago the Pennsylvania Railroad assembled at Altoona, Pa., two hundred officials and employees from the various sections of its system, and gave them practical instructions in the various first-aid treatments which would be applicable to those injured by electricity. When a man is injured by coming in contact with a fallen live wire, it is a dangerous matter

ing on a ladder, they may hold the nozzle within a few inches of the wire. The same experiment tried with an alternating-current line of 2,050 volts produced no reading at all in the voltmeter when the nozzle was held within 3 1/2 and 6 1/2 feet of the line, and the only effect noticeable was a slight static discharge when the nozzle was touched with the hand. A similar result was observed when playing the hose at the same distances on a 4,100-volt alternating-cur-

Prevailing direction, west; total movement, 11,012 miles; average hourly velocity, 16.4 miles; maximum velocity, 73 miles per hour. Weather: Clear days, 3; partly cloudy, 11; cloudy, 14; on which 0.01 inch or more of precipitation occurred, 12. Sleet, 9th, 23rd. Fogs (dense), 15th, 16th, 24th. Mean temperature of the past winter, 35.23; normal, 31.80. Precipitation of the past winter, 10.85; normal, 10.94. Deficiency, 0.9. Snowfall of the past winter, 16.

PROGRESS OF THE 20,000-TON "NORTH DAKOTA."

The accompanying photograph, taken at the yards of the Fore River Shipbuilding Company, shows the advanced stage to which the construction of our first battleship of the "Dreadnought" type, the "North Dakota," has been carried. The point of view from off the starboard quarter has been well chosen, for it gives a striking impression of the unusual gun-power of this great battleship. The total armament of ten 12-inch guns is mounted in five 2-gun turrets; two forward on the forecastle deck, the guns of the after turret firing above the roof of the forward turret, and three on the main deck abaft of the after mast. In our photograph the pair of 12-inch guns in the foremost turret are to be seen swung over, to starboard. The other turret is to be seen in course of assembling upon the dock in the middle foreground. This view is instructive as showing the plate framing of the turret before the roof and the side and front armor have been put in place. In the immediate foreground is one of this turret's 45-caliber, 12-inch guns. To the left of the breech of the gun lies one of the port shields, which are mounted upon the guns, within and close up to the port opening of the turret, for the purpose of preventing the entrance of shells. This shield moves with the gun as it is elevated or depressed, and serves to close the opening in whatever position the gun may happen to be.

Of the three turrets which show up so conspicuously on the after deck of the "North Dakota," the first is elevated sufficiently to enable it to fire dead astern

and hence, the American system assures a greater all-round efficiency for a given number of guns.

The series of triangular-headed vertical frames, which are seen hanging along the side of the "North Dakota," are the supports for the platforms from which the carpenters are engaged in bolting on the wooden backing for the side armor, a considerable portion of which, traceable on the photograph by its lighter shade, is already in place.

The "North Dakota" is a huge ship in every respect. Her length over all, 518 feet 9 inches, is equal to that of many ocean liners. Her beam of 85 feet 2½ inches is exceeded only by that of the "Lusitania" and "Mauritania." Her normal displacement is 20,000 tons and her full-load displacement over 22,000 tons. She will stow 2,500 tons of coal in her bunkers, and her Curtis turbines of 25,000 horse-power are designed to drive her at a contract speed of 21 knots, although on trial she will probably make over 22 knots. In addition to her main battery of ten 12-inch guns, she will carry fourteen 50-caliber 5-inch guns on the gun deck below. The protection will consist of a wide belt of armor, varying in thickness from 10 to 12 inches in the lower half of it, and from 10 to 8 inches in the upper half. As a protection against torpedo attack, her hull is being built with an unusually complete system of underwater subdivision, which is so elaborate that no single blow from the torpedo could sink her.

In respect to the speed with which she has been built, the "North Dakota" will mark an era in the progress of our navy. Although her keel was laid as late

4. All essays must be in the office of the SCIENTIFIC AMERICAN by April 1, 1909.

5. The Editor of the SCIENTIFIC AMERICAN will retain the small sealed envelope containing the address of the competitor and forward the essays to the Judges, who will select the prize-winning essay.

6. As soon as the Judges have agreed upon the winning essay, they will notify the Editor, who will open the envelope bearing the proper pseudonym and containing the competitor's true name. The competitor will be notified by the Editor that he has won the prize, and his essay will be published in the SCIENTIFIC AMERICAN.

7. The Editor reserves the right to publish in the columns of the SCIENTIFIC AMERICAN or the SCIENTIFIC AMERICAN SUPPLEMENT three or four of the more meritorious essays, which in the opinion of the judges are worthy of honorable mention.

Prof. Henry B. Manning, of Brown University, and Prof. S. A. Mitchell, of Columbia University, will be the judges.

Death of William A. Austin.

William A. Austin, who constructed one of the first steam carriages and steam bicycles, died on March 8th at Winthrop, Mass., at the age of 85. Despite his advanced age, Mr. Austin kept up his interest in inventions to the last. At the time of his death he was improving a gasoline lamp which was shortly to have been placed upon the market. Mr. Austin built a steam carriage at about the beginning of the civil war, and

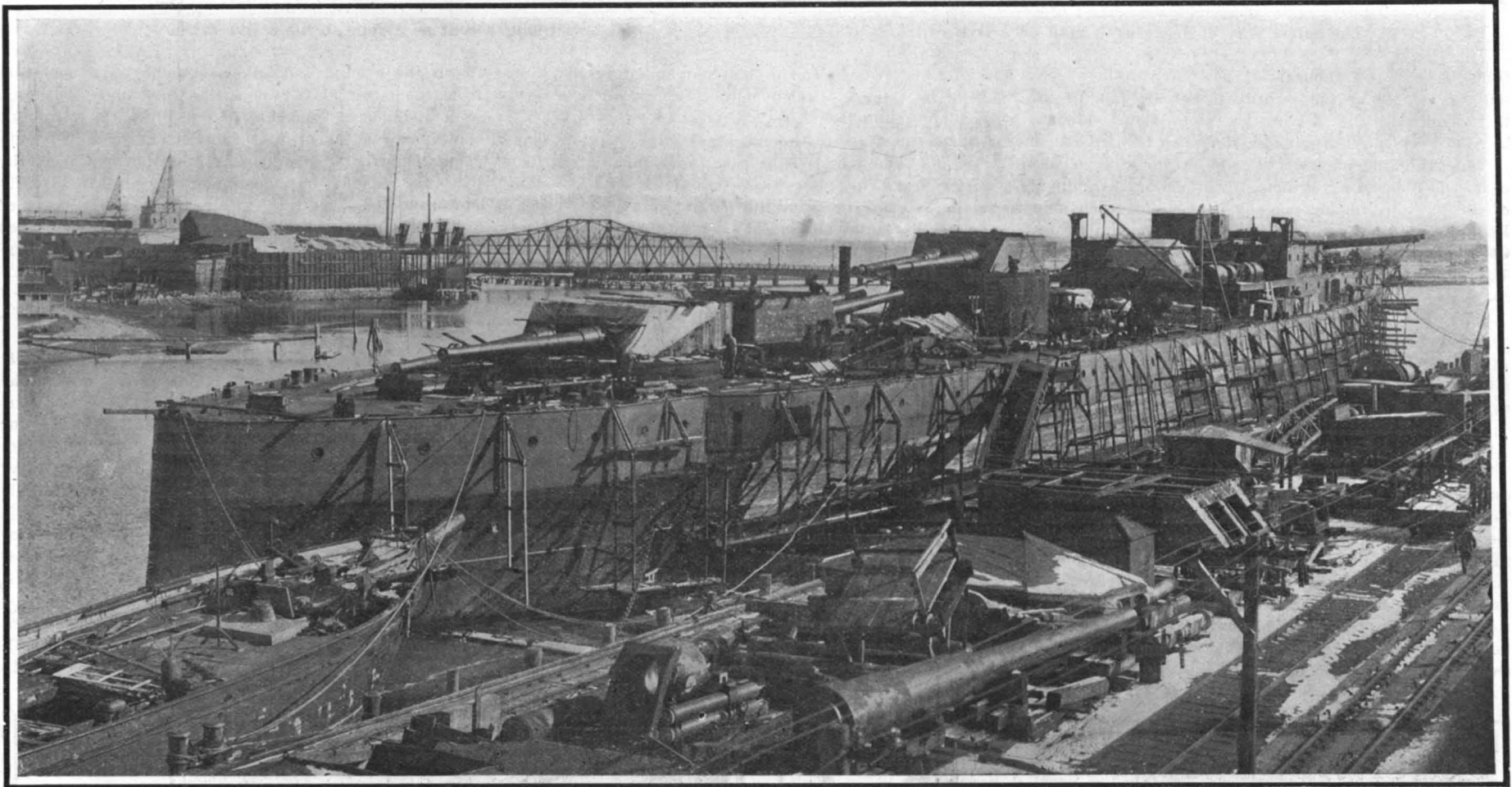

THE "NORTH DAKOTA," OUR FIRST "DREADNOUGHT," 80 PER CENT COMPLETED.

over the roofs of the two after turrets, so that if the "North Dakota" should be engaged in action with a ship or ships astern of her, she could concentrate the two guns in this turret and the two in the aftermost turret upon the enemy.

All five turrets are located on the longitudinal, center line of the ship, and all ten guns can be fired on either broadside. This is one of the excellences of the "Dreadnought" design, and indeed the credit for introducing the center line arrangement is due to our own naval constructors, with whom it originated. The arrangement affords a distinct advantage over the English system as used on the original "Dreadnought" and all subsequent ships of her type; for, although they also carry ten 12-inch guns, it is possible to concentrate on each broadside only eight of these guns. This limitation is due to the fact that two of the turrets are placed, one on each beam, with the superstructure of the ship intervening between them; and, consequently, on whichever side the ship is engaged, it necessarily follows that the broadside or "wing" turret of the opposite side is masked by the superstructure and cannot for the time being be brought into action. The English arrangement has the advantage that both of the wing turrets can be fired directly ahead or astern, which gives the ship a heavy end-on fire of six 12-inch guns, as against an end-fire of four 12-inch for the "North Dakota." It is unlikely, however, that much fighting will be done from the end-on position. Future engagements will be broadside to broadside;

as December 16th, 1907, she was launched November 10th, 1908, and at the present time is nearly 80 per cent completed. She will probably have her trials during the late summer or early autumn and, unless something unforeseen occurs, she will be completed several months before the contract date of June 21st, 1910.

A \$500 Prize for a Simple Explanation of the Fourth Dimension.

A friend of the SCIENTIFIC AMERICAN, who desires to remain unknown, has paid into the hands of the publishers the sum of \$500, which is to be awarded as a prize for the best popular explanation of the Fourth Dimension, the object being to set forth in an essay the meaning of the term so that the ordinary lay reader can understand it.

Competitors for the prize must comply with the following conditions:

1. No essay must be longer than 2,500 words.
2. The essays must be written as simply, lucidly, and non-technically as possible.
3. Each essay must be typewritten and identified with a pseudonym. The essay must be inclosed in a plain sealed envelope, bearing only the pseudonym. With the essay should be sent a second plain sealed envelope, also labeled with the pseudonym, and containing the name and address of the competitor. Both these envelopes should be sent to "Fourth Dimension Editor, SCIENTIFIC AMERICAN, 361 Broadway, New York, N. Y."

exhibited it throughout the country, with considerable profit to himself. Later he built a steam bicycle of phenomenal speed.

Collier "Prometheus" Launched.

On December 5th the collier "Prometheus," the first great steel vessel of the United States navy built at a navy yard on the Pacific coast, was launched at the Mare Island navy yard, Cal. The structural material for the "Prometheus" was received about the middle of September, 1907, and work began on October 1st, the keel being laid on October 18th. The construction thus occupied less than fourteen months and the "Prometheus" is further advanced at the launching than has been the case with any large vessel built previously at a United States navy yard. Notwithstanding the higher cost of material and labor on the Pacific coast, she will be completed at a smaller cost than the sister vessel that is being built at the New York navy yard.

An interesting series of experiments in wireless telegraphy were made not long since between portable stations which were installed one in the suburbs of Paris and the second at Melun. The messages were transmitted and also received with an antenna which has a very moderate height, this being not more than 60 or 70 feet. The antenna is designed so that it can be mounted within fifteen minutes by one or two men.



A PORTABLE AUTOMOBILE HOUSE.
BY W. M. BENNETT.

It is the purpose of this article to show how to build an automobile house which has the following advantages: It is portable, as all sections and other parts are held together with a minimum number of bolts and screws. It requires no special skill with

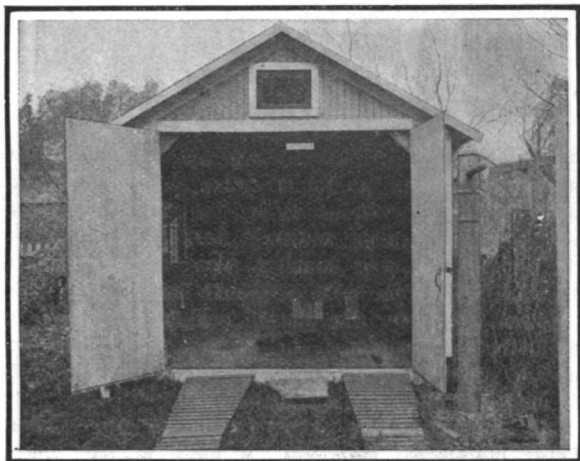

FRONT VIEW OF THE AUTOMOBILE HOUSE.

tools. It is easily set up and taken apart. It is light and sufficiently strong, and presents a neat and finished appearance.

The complete bill of materials for the house as shown herewith costs \$70. To this may be added about \$10 for paint. Because of its ready portability, it may be set up by the lake shore or in the woods and used as a summer cottage. It makes but one easy wagon load for two horses. It has no masonry supports, and therefore does not revert to the owner of the land on which it is placed, but it can be moved whenever moving day comes. The open doorway gives almost seven feet clearance, which is sufficient to admit an auto with top up. It is large enough for a small touring car with room to work all around it, as well as for the storage of supplies. With a run-about it gives room for shelves and a bench for a convenient workroom at the end.

The frame is of hemlock, Fig. 1, and measures 15 feet 4 inches by 9 feet 6 inches by 7 feet 8 inches high. Above the floors the frame consists of only four corner posts, the plate frame, two pairs of rafters, two

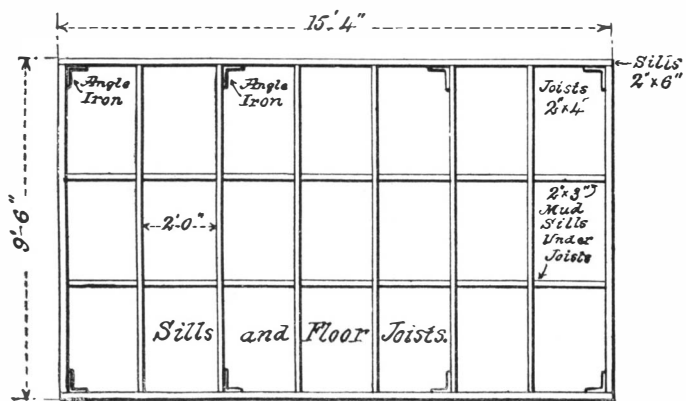
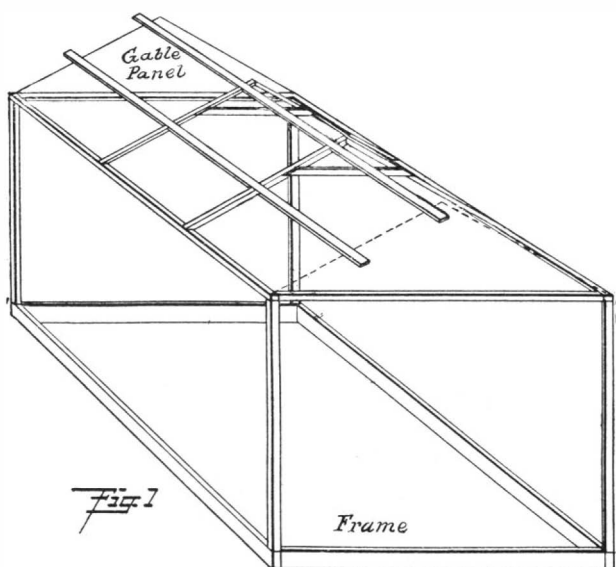

THE FLOOR PLAN AND FRAME.

tie-pieces—not shown—across from plate to plate at the foot of the rafters, all of 2-inch by 3-inch hemlock dressed, and four roof boards, 7/8 inch by 4 inches. The gable sections serve also as rafters. The sills are held together at the corners by angle irons 6 inches by 6 inches, 3/16 inch thick and 1 inch wide, fastened with carriage bolts 3/8 inch by 2 1/2 inches, Fig. 3. These should fit snugly in the sills, so that the square shoulders will prevent turning, and the heads are countersunk flush.

The floor joists rest on straps nailed to the side sills, Fig. 4. Two of the joists, Fig. 2, are fastened with lighter angle irons to prevent the sills springing outward. The rest are held in place by small cleats. Two mudsills, 2 inches by 3 inches, are laid under the joists to stiffen them for the load of the machine. These, as well as the whole frame, are blocked up and rest upon boards or plank pieces about 8 inches by 12 inches crossed and laid up under the sills at distances of four or five feet. If these supports settle by the action of frost, it is a simple matter to level up by adding more.

The corner posts stand on the sills, to be fastened later by corner boards, Figs. 3 and 5. The plate sticks are halved together at the corners, a hole is bored down through their ends into the top of the post, and a 24-penny wire spike is pushed into it. The plates are also held together by small angle irons at the corners. At this point the frame must be stayed up while the side and roof sections are put in place.

The side panels, Fig. 6, are of matched Georgia pine ceiling material, 7/16 inch thick, dressed and beaded one side, cleated with 3/8-inch dressed pine on the outside as shown, and cleated with a strip of the 7/16-inch material on the inside. They cover each 3 feet by 7 feet and are all interchangeable except that the corner sections are slightly modified to slip under the corner boards.

The window sections are made interchangeable with the rest, and the position of the windows may be varied to suit circumstances. The bevel on the cleats and on base and eaves boards, Figs. 7 and 8, aids in excluding the weather. The way in which the battens and cleats of the panels interlock to give tightness and strength is apparent from details of Fig. 6. Cleats, 2 inches by 7/8 inch, are fastened with 1 3/8-inch package wire nails, clinched on the outside. The inside cleat is fastened with 3/8-inch nails clinched inside. In general, the nailing is done with nails just long enough, so that the sharp points prick through slightly. The nail is driven against an iron block, and is really bent within the wood instead of forming a clinch visible outside.

In the window panel the frame is slotted on the sides to admit the battens. This panel is further stiffened inside by a frame of 3/8-inch stuff around the window opening. The double casement windows are factory made, sash 1 3/8-inch thick, and cost \$1.50 per pair or window. They are hung with parliament butts—separable—swing inside, and shut against the outside frame about 3/8 inch. The sill is beveled outside of foot of window sash, and a small square bead is run on the sill for them to shut against. The windows are rabbeted together with a simple L rabbet, and are then fastened inside with small bar bolts top and bottom.

The front gable section is framed of 3/8-inch pine, with the 7/16-inch siding nailed to it. The bottom board of this frame overhangs the front plate 1 1/2 inches, and the matched stuff rests on top of the plate. This leaves the lower 1/2 inch of the plate for the doors to shut against. The gable window opening is framed around with 3/8-inch stuff outside, and with 7/16-inch stuff inside. The gable window sash are home-made of 3/8-inch pine, and are hinged with separable butts to swing up for ventilation. The rear gable is slightly modified by narrowing up the bottom board and beveling it to overhang the plate 3/4 inch, and by fastening a beveled trim board to the plate to retain the panels below the plate in the same way, the side panels are held by eaves boards.

The floor is made in three sections strongly cleated underneath with cleats passing two inches beyond the

section edges to stiffen the joints between sections. The floor serves to retain the rear panels on the sill, but stops flush with the front face of front sill.

The front door is constructed of 3/8-inch pine. The top boards shut against the plate 1/2 inch, while the bottom boards shut against the ends of the floor. The matched stuff stands between the plate and the floor.

The roof sections have an overhang at the eaves of about 9 1/2 inches, and the same overhang at the gable ends. Ten sections cover 3 feet by 6 feet 4 inches each, and two sections cover 2 feet by 6 feet 4 inches. They have each three cleats of the same 7/16-inch material, the bottom cleat being only one inch wide. They are first cleated together (Fig. 9) with the end of a strip of unbleached factory cloth under the bottom cleat, which is nailed from the outside with all nails well clinched. The cloth is smoothed loosely over the section and cut off, and then the face of the section is given one or two coats of white lead mixed thin with

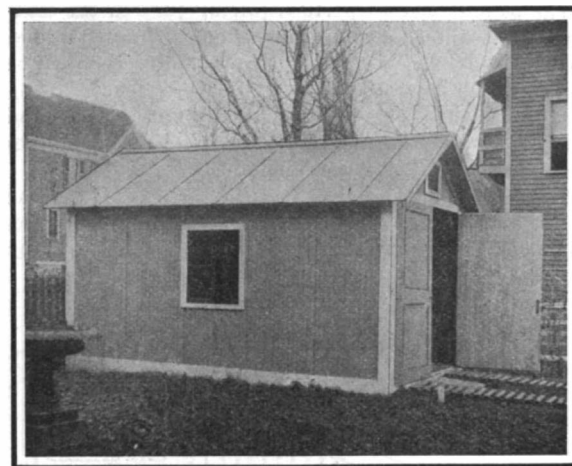

A SIDE VIEW OF THE PORTABLE AUTOMOBILE HOUSE.

raw oil and turpentine. After this dries the cloth is brought over, laid smooth without stretching, and tacked thoroughly at top and sides. Then a batten strip is nailed on at the left edge to cover the joint, as in the side panels. Care must be taken not to stretch the cloth, but to leave it as loose as possible without actual wrinkles, as it will shrink in the subsequent painting. The finished panel must now be given repeated coats of good paint until the cloth is filled and a glossy, weatherproof deck surface is formed. On each slope of the roof two roof boards of hard pine, 4 inches by 7/8 inch by 17 feet, are let into and flush with the rafters and gable sections and fastened with long screws.

After the frame is up, the base boards and eaves boards are temporarily tacked in place; then the panels are put in place from the inside, bottom end first; then the base and eaves boards are permanently adjusted and fastened to sill and plate with long screws. The corner boards are set together with screws, and then fastened in place with long screws into sill and post and plate. The panels next the corner boards are bolted to the corner boards at the middle cleat with roundhead stove bolts, using washers. The roof sections are held in place by stove bolts through the loose edge of the battens and the roof boards, and by screws into the plate. The ridge boards, one 4 inches,

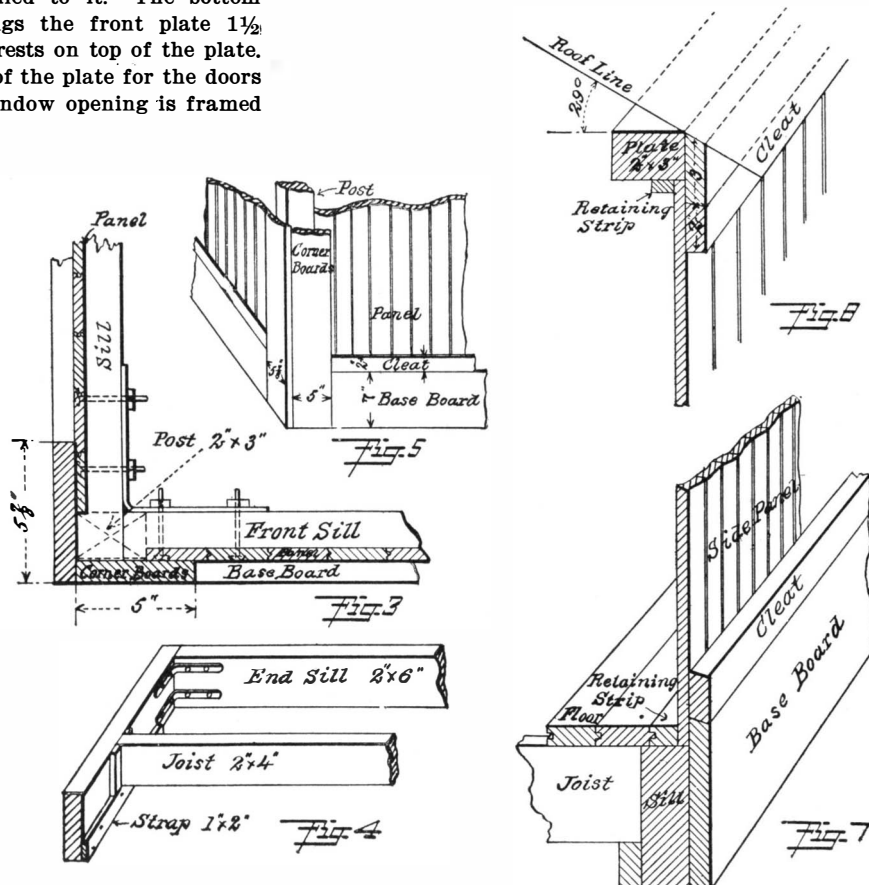

VARIOUS DETAILS OF CONSTRUCTION.

the other 5 inches wide, are beveled and put together with long wire nails. They are then put in place, and pieces of the 7/16-inch siding, 2 feet 9 1/2 inches long, are slipped under the ridge boards to level up between the battens, and stove bolts are put through the ridge board, understrip, and roof section. This fastening adds much to the strength of the roof. Finish boards of the 7/16-inch material should be cut and fitted at the gable edge of the roof to give a neat appearance. To stiffen the door opening, brace boards should be put across inside from plate to post at the upper corners of the opening.

In the work of erecting the building no fastenings are to be used but bolts and screws, and to facilitate the work, provide two bitstocks, one for a screwdriver bit, the other for a proper size gimlet. After the house is finished, it should have three coats of paint well brushed into the grooves in the beading, etc. The inside of the doors should also be painted, since they are frequently exposed to the weather.

The panels, and all parts requiring time in the making, can be put together in a shop of limited space, and given a coat of priming paint before erecting the building. This coat should be of white lead and oil, possibly shaded with lampblack ground in oil, and thinned well with turpentine, so that it will strike into the pitchy surface of Georgia pine.

The house shown has been in use for a year, and has proved both tight and strong, in contradiction to the critics of the plan, who thought it would do all sorts

- Finish Boards.—Second quality pine, 7/8 inch dressed and ripped, corner boards, 2 5 inches by 14 feet, 2 6 inches by 14 feet; base and eaves, 2 7 inches by 16 feet, 2 3 1/2 inches by 16 feet; base and rear plate, 2 7 inches by 16 feet, 1 2 1/2 inches by 12 feet..... 76 feet
- Roof and Ridge Boards.—Georgia pine, 7/8 inch dressed, 5 4 inches by 18 feet, 1 5 inches by 18 feet; window sills, white pine dressed, 1 2 inches by 3 1/2 inches by 7 feet..... 44 feet

AN INTERESTING EXPERIMENT AND ITS EXPLANATION

BY ALFRED P. MORGAN.

Ordinarily, the precipitate produced by mixing two chemicals in solution is formed more or less slowly. But in the following experiment we have a case where two different speeds of reaction are shown. The first takes several seconds before it is complete, while the second is quicker than a flash. The experiment also shows just when that action takes place.

When iodine is added to a starch solution, or vice versa, the solution is colored blue. This is a well-known test for either free iodine or starch.

Prepare a solution, A, of starch in water, and add to it some sulphurous acid. Prepare a separate solution, B, of potassium iodate, and add to it a little sulphuric acid. These last two substances form potas-

mixing the remainder. Care should be taken not to use too much sulphurous acid.

HOME-MADE SPRING WINDER.

BY J. O. BROUILLET.

Not long ago the writer was called upon to replace a broken spring in a machine. It had to be done at a moment's notice, as the work could not be held up.

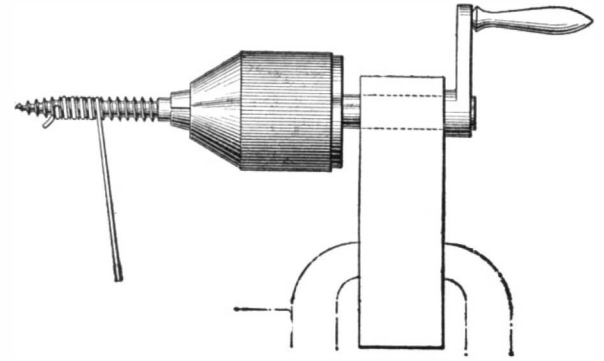

HOME-MADE SPRING WINDER.

The supply of springs was exhausted. The writer was given a piece of No. 60 wire, but no one had such a thing as a winder, so he was obliged to make one, and had a spring within a half hour.

In a junk pile was found a piece of soft steel, 4 x 1 1/4 x 1/2 inch wide, with a 1/2-inch hole in one end. A 1/2-inch lag screw was placed in a brace, a pinhole was drilled in the gimlet end of the screw, then putting the screw through the hole in the steel, which was held in a vise, the spring was easily wound.

This suggested the construction of the spring winder illustrated herewith. A piece of soft steel, 4 x 1 1/4 x 1 1/4 inch, forms the body. A 1/2-inch shank, fitted with a chuck taking from 0 to 1/2 inch, was run through the hole at the top and provided with a crank handle.

An assorted lot of lag screws serves for the open springs, and rods are used for the close springs and springs of oval or odd shapes.

FORGING A MASTHEAD OR BOOM RING.

BY I. G. BAYLEY.

On account of the severe strains to which the lugs on a masthead are subjected, they and the ring are usually made from one and the same piece of iron, instead of the former being welded on after the ring is made. The ring is made in two halves, the iron being cut sufficiently long to make two lugs, and go half way round the masthead or ends of main or jib boom. The comparative length of the iron is given in Fig. 1. The diameter of the bands, of course, varies, and the section of iron used is in proportion. The position of the lugs is marked out, and the bar heated and bent into shape (Fig. 2), the ends being shaped for welding, when the two halves are brought together, to form the circle. The lugs are closed and welded in the next heat (Fig. 3). Fig. 4 shows the half band, a similar one being made in the same manner. The holes for the wire ropes are countersunk on both sides, and are made at the roots of the lugs, close up to the bands. They are flattened out when being welded, their depth being a little more than the depth of the band, to give more metal in the direction of the pull.

To give a smooth surface on the inside of the band, a piece of metal called a "fish" is welded in the "gutters" formed at the roots of the lugs. These several details are shown in Fig. 5. The two halves are next welded, as shown in the completed band (Fig. 6). The outside edges of the band, top and

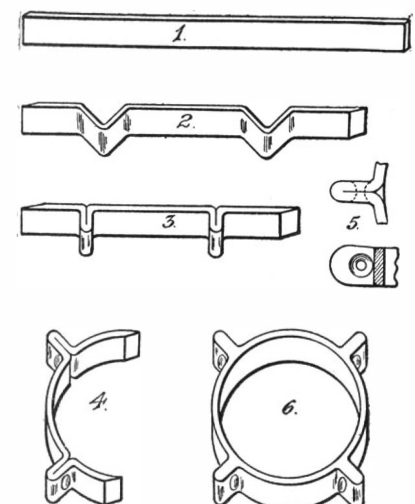

PROGRESSIVE STEPS IN THE FORGING OF A MASTHEAD.

bottom, are rounded off, and all sharp corners on the lugs removed, to prevent any accidental wear on the ropes. The top of the mast or ends of the booms are cut down to a shoulder, the thickness of the bands in width, and the bands driven on.

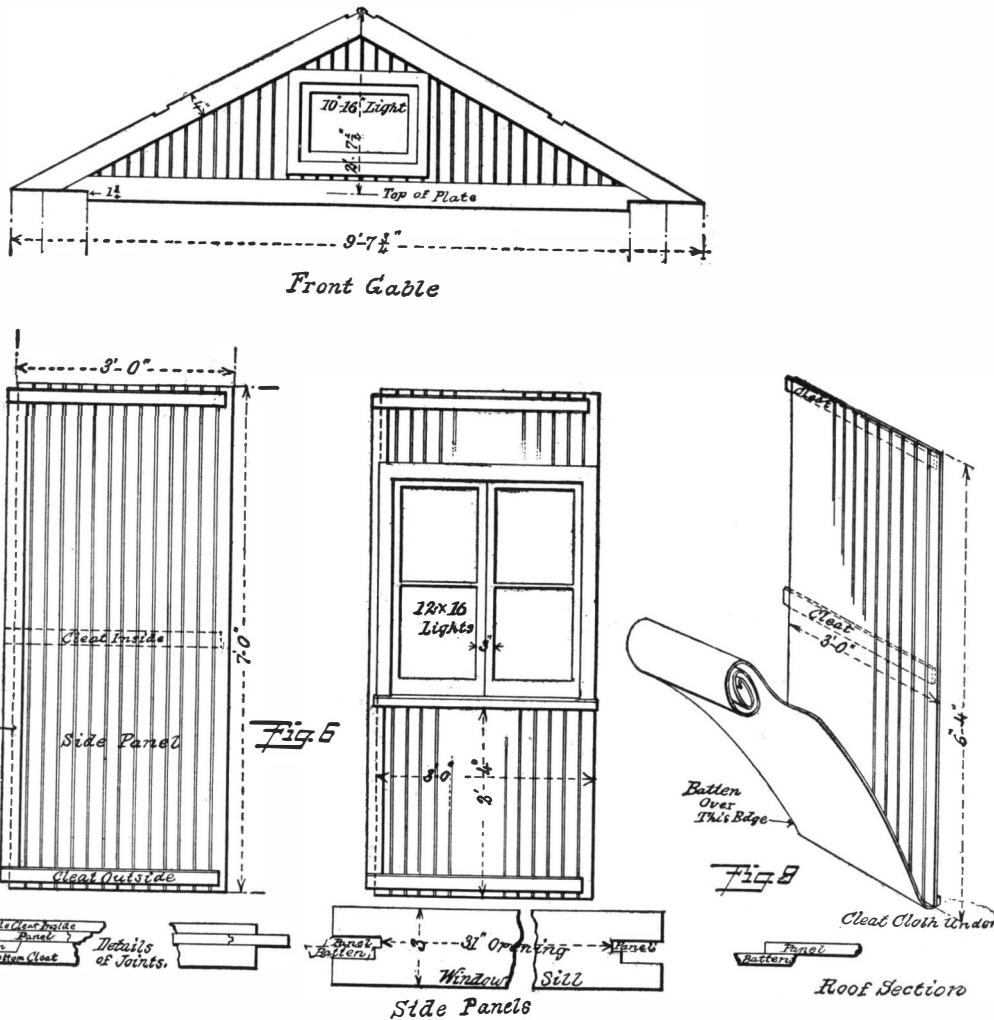

THE GABLE AND SIDE PANELS.

of undesirable things under the heat and rains of summer. It is most essential that it be well painted before the weather acts upon it, and that it be kept well painted.

LUMBER BILL.

- Side Panels and Roof Panels.—Matched and beaded Georgia pine ceiling stuff, 7/16 inch by 2 1/2 inches by 14 feet. Lengths to cover 700 square feet; add 1/4 for matching..... 875 square feet
- Sills, Mudsills, and Joists.—Rough hemlock, 2 sticks 2 inches by 6 inches by 16 feet; 1 stick 2 inches by 6 inches by 20 feet; 4 sticks 2 inches by 4 inches by 19 feet; 2 sticks 2 inches by 3 inches by 16 feet..... 119 feet
- Upper Frame.—2 inches by 3 inches dressed hemlock, posts, 2 sticks 14 feet; rafters, 2 sticks 12 feet; plates, 2 sticks 16 feet; 2 sticks 20 feet (1 for plate ties)..... 62 feet
- Floor.—Third quality pine flooring, matched and dressed, 16 feet long, cover 180 square feet, add 1/4..... 225 feet
- Framing Boards.—Of same stuff, 8 4 inches by 14 feet, 2 8 inches by 16 feet; cleats, 26 2 1/4 inches by 3 feet; next to doors, 1 8 inches by 16 feet; joist supports, 2 2 inches by 14 feet. approximate 150 feet

sium sulphate and iodic acid, in accordance with the following reaction:

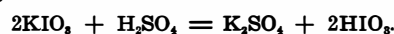

The iodic acid is the only constituent which plays any part and need be considered in the experiment proper. Pour A + B together quickly into a glass vessel and watch it closely. In a few seconds the solution will change like a flash to a deep blue. The explanation and reactions are as follows:

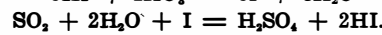
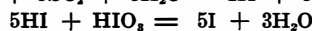

The iodic acid unites with the sulphurous acid to form hydriodic acid and sulphuric acid. The iodic acid then unites with some of the hydriodic acid and forms iodine. But the iodine does not get a chance for existence, because it is immediately taken up by some of the sulphurous acid and formed into iodic acid. This process keeps on as long as there is any sulphurous acid present, and the solution remains clear, for there is also no free iodine present. But just as soon as the last molecule of sulphurous acid disappears, the whole solution turns blue so quickly that one looks twice before believing. The blue color generally flashes in from 20 to 40 seconds, depending upon the concentration and strength of the solutions. With a little experimenting the solution may be made to change in a predetermined time. It is a good idea to use a small part of the solution, and time it before

The Prudential

made the

Greatest Gain in Insurance in Force

in 1908,

of Any Life Insurance Company in the World!

Giant Strides of a Giant Company:

Gain in Life Insurance in Force, in 1908, over	-	-	-	97 Million Dollars
Paid Policyholders, during 1908, over	-	-	-	19 Million Dollars
Dividend Fund to Credit of Participating Policies, Decem- ber 31, 1908, nearly	-	-	-	15 Million Dollars

Total Payments to Policyholders Since Organization, plus Amount Held at Interest to Their Credit, Over 313 Million Dollars!

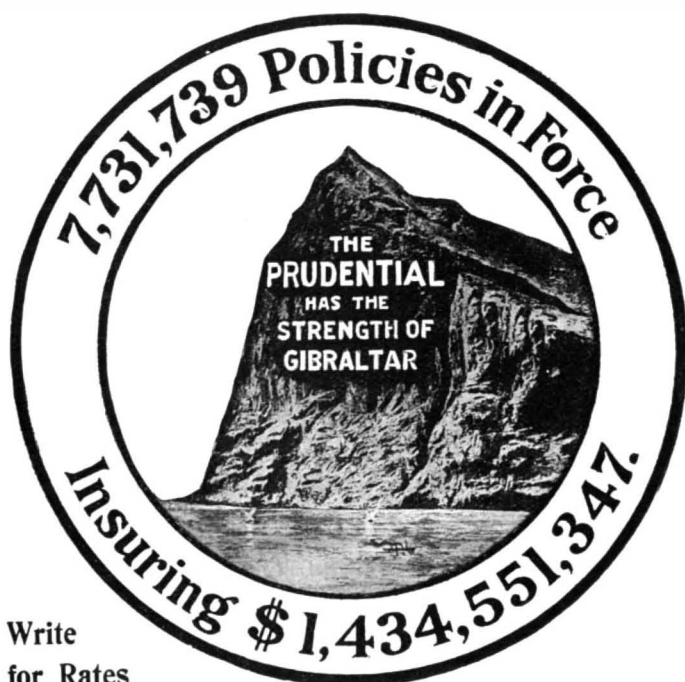

Write
for Rates
of New Low Cost
Policy. Dept. 121

OTHER 1908 FEATURES

Expenses Reduced.

New Monthly Income Policy Inaugurated.

Loaned to Policyholders, on Security of their Policies, to Dec. 31, 1908, over 10 Million Dollars.

Tax Payments in 1908, nearly 1¼ Million Dollars.

The Prudential Insurance Co. of America.

Incorporated as a Stock Company by the State of New Jersey.

JOHN F. DRYDEN, President.

Home Office, Newark, N. J.

lime may be washed out if the cement is sufficiently pervious, more being formed by fresh sea water attacking the lime until the latter is destroyed.

NEW BOOKS, ETC.

A HANDBOOK OF SMALL TOOLS. By Erik Oberg. New York: John Wiley & Sons, 1909. 517 large 12mo. pp.; 282 illustrations; cloth. Price, \$3.

In the present multiplication of books on all sorts of subjects it is comparatively rarely that one comes across a new publication the subject of which has not already been treated, less comprehensively or less thoroughly or simply earlier, but the present work seems to fill not a "long-felt want" so much as a recently arisen and hitherto unmet want.

HOW IT IS DONE: OR, VICTORIES OF THE ENGINEER. By Archibald Williams. New York: Thomas Nelson & Sons, 1908. 12mo.; cloth; pp. 484; 268 ill. Price, \$1.25.

In this book the author has described in simple language how the great engineering feats of the world have been accomplished. Among the subjects treated are railroad engineering, the building of a big ship, bridge building (including an account of suspension and cantilever bridges and detailed descriptions of the Forth Bridge, Blackwell's Island Bridge, and the collapse of the Quebec Bridge).

Table listing various mechanical parts and their prices, including items like Animal trap, Automatic fountain, Automobile air cushion, and various types of pumps and valves.

Economical Production and shop equipment that is unequalled in facilities and management. "Star" Lathes for belt or foot power at most moderate prices.

Engine and Foot Lathes. MACHINE SHOP OUTFITS, TOOLS AND SUPPLIES. BEST MATERIALS. BEST WORKMANSHIP. CATALOGUE FREE.

Foot and Power and Turret Lathes, Planers, Shapers, and Drill Presses. SHEPARD LATHE CO., 133 W. 2d St. Cincinnati, O.

THE "BARNES" Upright Drills. Positive Feed. 10 to 50-inch Swing. Send for Drill Catalogue.

"Bougie Eyquem" The FRENCH SPARK PLUG that Protects Your Coil and Magneto. A plug that surpasses anything on the market.

Pipe Cutting and Threading Machine. For Either Hand or Power. This machine is the regular hand machine supplied with a power base, pinion, countershaft, etc.

Safety Razors FREE. To quickly introduce the celebrated Ideal Shaving and Complexion Soap which beautifies, removes pimples, blotches and all facial eruptions.

How to Construct An Independent Interrupter. IN SCIENTIFIC AMERICAN SUPPLEMENT, 1615. A. Frederick Collins describes fully and clearly with the help of good drawings how an independent multiple interrupter may be constructed for a large induction coil.

THIS IS THE ONLY Correspondence School formulated on practical engineering lines for giving instruction in Modern Cost Systems; Factory and Commercial Office Systems; Manufacturing Methods and Systems; Shop Organization and Management; Shop Construction and Equipment; Pattern Shop and Foundry Systems; Mechanical Drawing; Mechanical Engineering, etc.

Modern Systems Correspondence School. Executive Offices, 6 Beacon St., Boston. OSCAR E. PERRIGO, M. E., Educational Director (Consulting Mechanical Engineer).

Modern Systems Correspondence School. Fill out, check subject and send us TODAY the following coupon and we will mail you FREE our Prospectus of valuable information:

Form for requesting a prospectus from the Modern Systems Correspondence School, including fields for Name, Occupation, Address, and City.

Table listing various mechanical parts and their prices, including items like Disks, cutting, Door catch, Door catch, Door controlling device, Door hanger, Door lock, Double acting clamp, Dough raising apparatus, Draught level, Dressmaker's gage and stand, Drill adjusting device, Drilling machine, Dust pan, Dynamite machine, Electric accumulator plate, Electric cigar lighter, Electric controller, Electric current and voltage regulator, Electric furnace, Electric igniter switch, Electric light cord or cable adjuster, Electric light, portable, Electric switch, Electric switch shunt contact, Electrical insect destroyer, Electrically operated brake, Electricity, device for vending, Electricity rectifier, Electrode for arc lights, Electrolytic apparatus, Electrotyping plates, Elevating and cleaning material of a granular nature, Elevator and mine cage breakaway clutch, Embroidery needle, machine, Engine, Engine electric ignition apparatus, Engine explosive mixture, combustion, Engine starting mechanism, internal combustion, Engine steering device, traction, Engineer's alarm, Envelope seal, Explosive engine, Epelet, Fabric and weaving the same, Fabric bleaching and dyeing machine, Fan, electric, Fare box, Faucet, Faucet combination the, Feeder, poultry, Fence post, Fender, Filing system, Film frame carrier, adjustable, Filter, C. R. Perry, Filter press plate, Fire escape, Fireproof floor, Maglie, Fire protection, Firearm auxiliary stock, Fish hook, Fish hook, C. M. Willis, Flask, molder's, Flue stopper, M. F. Stearling, Fluid circulating and cooling apparatus, Flushing apparatus, Food products and making same, Frame for molders' use, extensible, Friction insert for braking surfaces, Fruit picker, Fruit stand, folding, Fruit stand, F. H. Sabo, Fuel, compound, Furnace charging apparatus, blast, Furnace, apparatus for feeding flour iron ore to blast, Furniture, adjustable, Furniture, adjustable, Furrow opening attachment, Galvanizing machine, Game apparatus, Game register, pool and billiard, Garbage receptacle, Gas conduits, combined liquid separator and indicator for, Gas, generating, Gas producer, Gate frame, hinge, Gate operating mechanism, automatic, Gate, W. Patterson, Gear, friction transmission, Gear, reversing, Gearing, changeable speed, Gears, forming herring bone, Gears, means for casting, Glass drawing apparatus, Glass gathering and shaping machine, Glass making decorative, Glassware carton, Golf apparatus, Grain separator, Grain shocking apparatus, Granophone, Grapple, Gravity conveyor, automatic, Grinding device, Grinding machine, Hammer and hammer support, Hammer drop board, Hammer, hanging, Handle fastening, Harness hanger and stretcher, combined, Harvester, corn, Harvester device, Harvester snapping roller, Hat brim press to form welt edges, Hay stacker, Head rest, Heater, G. L. Fogler, Heater, L. B. Piper, Hedge trimmer, Hedge trimmer, Heel building machine, Hinge, A. Krauth, Hinge and article hanger, combined, Hoisting attachment and cornice protector, Hook, See Fish hook, Horn, amplifying, Horse detacher, Horseshoe, C. Wernstrom, Horseshoe, A. F. Paulsen, Hot air register, Humidifying and air conditioning apparatus, Hydraulic motor, Igniter, Mantion & Stanley Illuminator, Index, L. Dennick, Indicator contact maker, Insect trap, Heath & Martin, Insecticide, Insele cleaning machine or device, Noonan, Internal combustion engine, Invalid's supporter, Iron cutter, Ironing board, Ironing machine, Jar or bottle stopper, Joint chair, railway, Journal box lubricating device, Kinetoscope, Ladder, A. H. Loomis, Lamp, P. Heyland, Lamp, arc, W. F. Warner

Legal Notices. 60 YEARS' EXPERIENCE. PATENTS. TRADE MARKS, DESIGNS, COPYRIGHTS &c. Anyone sending a sketch and description may quickly ascertain our opinion free whether an invention is probably patentable. MUNN & Co. 361 Broadway, New York.

INDEX OF INVENTIONS. For which Letters Patent of the United States were Issued for the Week Ending March 9, 1909, AND EACH BEARING THAT DATE. [See note at end of list about copies of these patents.]

Table listing various mechanical parts and their prices, including items like Abdomen compress, Acid, Addressing machine, Advertising device, Aeroplane, Air brake automatic coupling, Air moistener, Airship, Curling iron, Current indicating apparatus, Current motor, Curtain pole, Curtain supporter, Cuspidor, Cutting, piercing, and marking pen machine, Cycle, C. S. Johnston, Dam, W. G. Fargo, Dam crest, automatically movable, Delivery mechanism, Deodorizing and disinfecting device, Derrick pile driver, Detuning, von Kugelgen & Seward, Die stock, adjustable, Dipping machine, Disinfecting apparatus, V. A. Williams

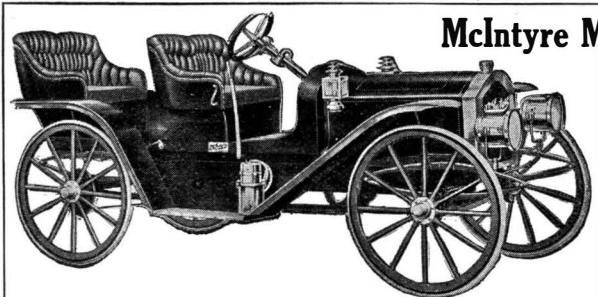

McIntyre Model M—\$850

Wheel Base—111"
Motor—Four-cylinder vertical, 4 1/2" x 3 3/4"
Horse Power—28-32
Transmission—Planetary; 2 forward speeds, 1 reverse.

McIntyre

High-Wheel Motor Vehicles

Yes, high wheels! Why not? The highest priced automobiles have been coming gradually but surely to the high wheels. Not so very long ago 28-inch and 30-inch wheels were considered correct. Today they are found only on cheap cars.

McIntyre Motor Vehicles give perfect service in town or country—over any kind of roads—mud, sand or hills—speed, 30 miles an hour—economical—simple—good style.

W. H. McINTYRE COMPANY, Auburn, Indiana
256-257 Broadway, New York
1730 Grand Avenue, Kansas City, Mo.

McIntyre Model H H—\$510

Motor—Double cylinder, opposed offset, 4 1/2" x 3 3/4"
Horse Power—12-14.
Transmission—Planetary; 2 forward speeds, 1 reverse.



- Lamp, arc, W. R. Whitney 915,052
Lamp, electric arc, C. Oliver..... 914,868
Lamp, electric arc, Fleming & Halvorson... 914,939
Lamp, hydrocarbon incandescent, H. H. Eason 914,709

Our Improved Method of FINISHING FLOORS old or new, for rugs or otherwise, with GRIPPIN'S FLOOR CRACK FILLER AND FINISHES



"Is That Your Collar?" Killing the Collar. A collar gets most worn when not worn—chewed up and rubbed to death at the laundry.

MOTORCYCLES BICYCLE MOTORS 100 New Motorcycle Accessories. Everyone interested in Motorcycles should have our big catalog.

GAS ENGINE DETAILS.—A VALUABLE and fully illustrated article on this subject is contained in SUPPLEMENT No. 1292.

GEER MOTORCYCLES 5-H. P. 2-Cylinder Green Egg, \$225.00
4-H. P. Bluebird 200.00
2 1/2-H. P. Geer, Model 4. 150.00

Instructive Scientific Papers ON TIMELY TOPICS Price 10 Cents each by mail

ARTIFICIAL STONE. By L. P. Ford. A paper of immense practical value to the architect and builder. SCIENTIFIC AMERICAN SUPPLEMENT 1500.
THE SHRINKAGE AND WARPING OF TIMBER. By Harold Busbridge. An excellent presentation of modern views; fully illustrated. SCIENTIFIC AMERICAN SUPPLEMENT 1500.

Patent For Sale Electric Motor

Palmer Motors Two and Four Cycle. One, Two and Four Cylinder. Stationary and Marine. One to Twenty H. P. Catalogue FREE.

BE A TRAVELING SALESMAN We have trained hundreds of men who had no former experience as salesmen and who formerly earned from \$25 to \$75 per month to be Traveling Salesmen and assisted them to secure positions on the road when they have since earned from \$100 to \$500 per month and expenses.

Dwiggins Lifetime Quality Fences "Cost Less Than Wood" LAWN, FARM AND POULTRY FENCES.

The Banking and Currency Problem in the United States By VICTOR MORAWETZ THE author takes up the problem of the National Monetary Commission, appointed by Congress, and discusses the means of providing a permanent safeguard against money stringencies and panics.

Classified Advertisements

Advertising in this column is 75 cents a line. No less than four nor more than ten lines accepted...

Inquiry No. 8947.—For the manufacturers of a machine to compel deep breathing called "Pneumaxeter."

BUSINESS OPPORTUNITIES.

MAKE \$250 TO \$500 PER MONTH.—I will teach you the Real Estate Business by mail and appoint you my Special Representative.

INQUIRY NO. 8868.—Wanted to buy nickeloid for buttons.

DONT LET YOUR PATENT LIE IDLE. We'll make dies and tools and manufacture your article ready for market.

INQUIRY NO. 8877.—For manufacturers of convex glass for pictures.

WANTED.—Party to manufacture and promote sale of Brake Lever Pat. No. 912,586.

INQUIRY NO. 8885.—For manufacturers of the "Mysterious Ball" like that of Mr. Lepere's—a man in a ball.

PATENTS FOR SALE.

FOR SALE outright patent 901,124, Oct. 13, 1908. Air agitator device for value bearing solutions or any solution requiring constant agitating.

INQUIRY NO. 8889.—Wanted to buy a machine which breaks and divides apricot stones.

FOR SALE.—Patent rights 702,249. The May-Bell-Smoking Pipe. The only sanitary pipe that effectually removes the nicotine and other impurities, collects and absorbs them so they cannot reach the mouth.

INQUIRY NO. 8894.—For manufacturers of an automatic camera for making photographs on pin trays, etc.

PATENT FOR SALE.—Figures and print in paper, invisible when the paper is dry, visible when wet.

INQUIRY NO. 8897.—For the manufacturers of the "Lid on" can opener.

FOR SALE or on royalty, Pat. No. 902,877. Practical and simple music leaf turner.

INQUIRY NO. 8903.—For firms dealing in motor cars to suit Indian climate.

AGENTS WANTED.

AGENTS WANTED for new 25c. darning machine; just out. Weaves new heel or toe in sock in few minutes.

INQUIRY NO. 8904.—Wanted to buy new or second hand machinery for making "bow type" mouse and rat trap springs and wire parts, single machine or full outfit.

STAMPS AND COINS.

WE BUY U. S. and foreign coins many dates and denominations; premiums up to \$5.00. Also every kind of used stamps. Particulars free.

INQUIRY NO. 8908.—For a dealer in tapes and cords for Venetian blinds.

FOR SALE.

FOR SALE or to place on royalty. Latest and best sanitary telephone transmitter mouthpieces ever invented.

INQUIRY NO. 8909.—For a machine to paint shade or blind rollers.

LISTS OF MANUFACTURERS.

COMPLETE LISTS of manufacturers in all lines supplied at short notice at moderate rates. Small and special lists compiled to order at various prices.

A LIST OF 1,500 mining and consulting engineers on cards. A very valuable list for circularizing, etc.

INQUIRY NO. 8918.—For manufacturers of "Wydt's Electro-Catalytic Sparking Plug."

MISCELLANEOUS.

WANTED.—One good second-hand drill press about 25-inch back geared. Must be cheap in price.

INQUIRY NO. 8920.—For a still for extracting alcohol from saw dust.

UNITARIAN LITERATURE, including sermons and weekly publications, sent free, on application to Miss Peck, 106 George Street, Providence, R. I.

INQUIRY NO. 8921.—For the manufacturers of gilt paper.

INQUIRY NO. 8922.—Wanted the address of Worthington Boiler Co.

INQUIRY NO. 8926.—Wanted to buy a tree digger of steel plates which are forced down beside the tree and locked in position.

INQUIRY NO. 8927.—Wanted to buy an apparatus for sterilizing water at the tap by an ozonizer.

INQUIRY NO. 8928.—For the manufacturers of a steam rotary excavator as described in the Scientific American of December 12, 1908, page 347.

INQUIRY NO. 8931.—For parties who manufacture the Western Stamp Borer for boring stumps.

INQUIRY NO. 8934.—Wanted to buy seal and book of blank stock certificate.

INQUIRY NO. 8936.—Wanted machinery used to spin or wrap paper pencils in the manner that paper pencils are made.

INQUIRY NO. 8941.—For manufacturers of machinery for making fly screens.

INQUIRY NO. 8942.—Wanted to buy apparatus to enable anyone with rheumatism or other causes to hold a penholder.

INQUIRY NO. 8943.—Wanted a portable hand machine for breaking stones for installing road surface.

INQUIRY NO. 8944.—For the address of the manufacturers of the King or lever collar button.

INQUIRY NO. 8948.—For manufacturers of gearing, noiseless or otherwise, suitable for speed of 3,000 to 4,000 r. p. m. for wheels 5 inches diameter.

INQUIRY NO. 8950.—For manufacturers of machinery for the production of Coquito, Palm, Babosa, and Mame seed or nuts.

INQUIRY NO. 8951.—For manufacturers of machinery for making milk bottle sanitary fiber caps.

INQUIRY NO. 8952.—For firms making apparatus for using oil for fuel under a steam boiler instead of coal.

INQUIRY NO. 8953.—For manufacturers of water turbines.

INQUIRY NO. 8954.—For machinery used in manufacturing collar buttons.

INQUIRY NO. 8955.—For a machine to extract the small kernel from the pea-nut.

INQUIRY NO. 8956.—For makers of wood distilling machinery, also makers of philosophical instruments and chemists' hardware.

INQUIRY NO. 8957.—Wanted manufacturers of angle bars either malleable steel or sheared.

INQUIRY NO. 8958.—For the manufacturer of a drier for sugar beet pulp.

INQUIRY NO. 8959.—For manufacturers of any platinum sponge gas lighter.

INQUIRY NO. 8960.—For the address of the Windsor Mfg. Co., manufacturers of waterproof collars and cuffs.

Tie attachment, W. T. Hulscher 914,416

Tile, J. A. McKee 914,862

Time indicating device, S. P. Thrasher 914,534

Tire, vehicle, W. D. McNaull 914,589

Tire, wheel, J. Christy 914,551

Towel article, H. Straus 914,682

Tongue depressor, E. Hubbell 914,415

Tool, combination, E. H. Nylin 914,601

Tool, engraving, H. W. Wells 914,621

Outdoor America

"A Magazine Within a Magazine"

COLLIER'S will print, once every month, an eight-page section entitled Outdoor America.

It will be edited by Caspar Whitney, formerly editor of "Outing" magazine, whose writings will be supplemented by many able contributors.

It will endeavor to stimulate interest in all outdoor activities.

Advertisers of outdoor requisites are assured of a large circle of readers who are especially interested and ready to buy.



Collier's The National Weekly

E. C. PATTERSON Manager Advertising Department

NEW YORK BOSTON CHICAGO

SMALL HOUSE NUMBER of AMERICAN HOMES AND GARDENS

THE artistic and inexpensive house is the chief demand of the home seeker of to-day.

This issue will contain a vast amount of valuable information for the prospective home builder.

THE ARTISTIC EXPRESSION OF THE SMALL HOUSE is well explained in an article by Francis Durando Nichols.

PLUMBING FOR A SMALL COUNTRY HOUSE, by John A. Gade, is a very important subject.

THE MAKING OF AN IRIS GARDEN, by Samuel Howe, is an illustrated article showing how a swamp or lowland can be developed.

DECORATIVE FEATURES IN THE SMALL HOME, by Alice M. Kellogg, presents in a brief way with ten illustrations artistic schemes of covering the floors and walls of the house.

A GROUP OF MODEL MOTOR HOUSES FOR THE SMALL COUNTRY PLACE, by Ralph de Martin, forms two pages of illustrations.

HOME-MADE NOVELTIES FOR THE COUNTRY HOUSE, by Mabel Tuke Priestman, treats of the conversion of unlikely things into useful articles.

THE EVOLUTION OF THE SMALL HOUSE PLAN, by Joy Wheeler Dow, is an important article by a well-known architect.

A FORMAL GARDEN AND PERGOLA, DESIGNED BY AN AMATEUR, by Alexander R. Holliday, informs the reader how an amateur planned and laid out his garden.

PROPER FURNITURE FOR THE SMALL HOUSE, by Esther Singleton, with illustrations showing the artistic and appropriate furniture for the house.

THE USE OF CONCRETE IN THE BUILDING OF A SMALL COUNTRY HOUSE, by Benjamin Howes, is a timely and comparatively new subject.

THE HEATING APPARATUS FOR THE SMALL COUNTRY HOUSE, by Allyn Frogner, is the title of an article treating in a practical manner one of the most important features of a small country house.

PROBLEMS IN PLANNING THE GROUNDS OF A SMALL COUNTRY PLACE, by Charles D. Lay, Mr. Lay has explained in a very concise form how the grounds around a small country place may be planted.

This SMALL HOUSE NUMBER will contain 165 illustrations covering 52 pages, which will be enclosed in a striking colored cover.

The price will be fifty cents. Those now subscribing for American Homes and Gardens for the year will receive it at the regular rate.

MUNN & COMPANY, Publishers, 361 Broadway, New York City

DESIGNS.

Bath tub for bird cages, M. Boegner 39,869

TRADE MARKS.

Alfalfa meal or ground hay used as a stock food, M. C. Peters 72,989

COLD GALVANIZING.
AMERICAN PROCESS NO ROYALTIES.
SAMPLES AND INFORMATION ON APPLICATION.

NICKEL
AND
Electro-Plating
Apparatus and Material
Hanson & Van Winkle
Co.,
Newark, N. J.
28 & 30 S. Canal St.
Chicago.



TORREY STROPS

This Side Sharpens a Razor

If your razor won't clip a hair clean and quick, pass it a few times up and down the canvas side of a Torrey Strop Then—

This Side Finishes the Edge

A few strokes on this soft, fine grained finishing side, and you're ready to shave with ease.

Torrey Stropps are sold everywhere—50c, 75c, \$1.00, \$1.50, \$2.00 and \$2.50.

If not with your dealer, we will send one by mail postpaid on receipt of price.

Torrey's **OH-Edge** Dressing keeps a strop soft and pliable. 15c at dealers or by mail.

Ask for Torrey Stropps and Razors. Write for free catalog containing valuable information for men who shave.

J. R. TORREY & CO.
Dept. G, Worcester, Mass.



LEARN TO BE A WATCHMAKER

Bradley Polytechnic Institute
Horological Department
Peoria, Illinois
Formerly Parsons Horological Inst.
Largest and Best Watch School in America

We teach Watch Work, Jewelry, Engraving, Clock Work, Optical. Tuition reasonable. Board and room near school at moderate rates. Send for Catalog of Information.

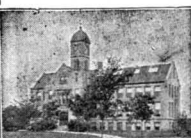

CRUDE ASBESTOS
DIRECT FROM MINES

PREPARED ASBESTOS FIBRE for Manufacturers use

R. H. MARTIN,
OFFICE, ST. PAUL BUILDING
220 B'way, New York.

WIRELESS

The "Electro" Lytic Barepoint Detector is the most sensitive detector on the market. When used in connection with a few other instruments not costing over 50c., clear messages from commercial stations 100 miles away are received with perfect clearness.

This enables everybody to learn telegraphy Free of Cost.

Price of detector \$1.50, by mail extra 12 cents.

Send 2c. postage for our electrical encyclopedia, No. 6, 120 pages, 150 illustrations, and wireless sets from 1-1000 miles.

ELECTRO IMPORTING CO., 84a West Broadway, NEW YORK CITY
"Everything for the Experimenter"



WHY NOT BE AN ARTIST?

Our graduates are filling High Salaried Positions. Good artists **EARN \$25 TO \$100 PER WEEK** and upwards, in easy fascinating work. Our courses of Personal Home Instruction by correspondence, are complete, practical. Eleven years' successful teaching. Expert instructors. Positions guaranteed competent workers. Write for Handsome Art Book, Free.

SCHOOL OF APPLIED ART (Founded 1898.)
N 145 Gallery Fine Arts, Battle Creek, Mich.

A Cheap Water Power

As a reliable and economical water power for public institutions, farmers, owners of factories and country homes, the

Niagara Hydraulic Ram

has no equal. Better than a gasoline engine or windmill. Send for booklet and estimate. We furnish Caldwell Tanks and Towers.

NIAGARA HYDRAULIC ENGINE CO.,
140 Nassau St., N. Y. Factory, Chester, Pa.



TYPEWRITERS ALL MAKES

Visible Writers or otherwise **Olivers, Remingtons, Smiths, etc.**

Shipped ANYWHERE for Free Trial, or RENTED, allowing RENT to APPLY.

Prices \$15.00 Up

First class Machines fresh from the Manufacturers Write for Illustrated Catalog 10. Your opportunity.

TYPEWRITER EMPORIUM, (Est. 1892) 92 & 94 Lake St., Chicago



CONCRETE HOUSES

Cost Less Than Wood

More handsome than Brick, Durable as granite. A Pettyjohn \$35.00 concrete block machine, sand, gravel and cement are all that is needed. Simple, easy and quick. We furnish full instructions. Save money for yourself or make money by selling blocks.

Write for catalog and suggestions

THE PETTYJOHN CO., 615 N. Sixth Street, Terre Haute, Ind.



WE WILL MAKE your models and give you estimates on manufacture of any metal novelty. Automatic machinery, tools, dies and expert work our specialty.

AUTOMATIC HOOK & EYE CO., Hoboken, N. J.

WRITE FOR THIS BOOK ON THIS FULL 18-20-Horse Power Goes the Route CAR that ALWAYS

Not "an engine in a buggy" but built up from highest type Chassis carrying powerful water-cooled motor. Speed 1 to 30 miles. Goes 25 miles on one gallon of gasoline.

THE INVINCIBLE AUTO-RUNABOUT SCHACHT

Handsome lines and finish—Regular auto appearance—High wheel style best for all roads—sand, mud and mountain climbing. Economy of first cost and long life durability. Quick control from steering wheel—Friction drive—Double chain to each rear wheel—Absolutely gearless and clutchless—Puncture proof Goodrich solid rubber tires—Timken roller bearings—Schebler carburetor, etc. All of highest quality. Write for price—Free books as prospective buyer or special offer to agents.

THE SCHACHT MANUFACTURING CO., 2700 Spring Grove Ave., Cincinnati, Ohio



A Simple, Powerful, Durable Comfortable Car

International Auto Buggy

If the business man or professional man will give one hour's study to the International Auto Buggy he will understand why we say this simple, powerful, comfortable, durable car is the one car best fitted to his requirements. It is made for him.

The International Auto Buggy will run on paved city streets. Of course. And with good speed and desirable comfort, and almost silently, too. But, primarily, it is made for service—for the physician, the merchant, the farmer, the rural salesman—for every season, every day, every kind of roads.

We would be glad to demonstrate to you the power, simplicity, ease of control, comfort, usefulness of the International Auto Buggy—to show you how much of value it would mean to you in business, how much of pleasure in your family life.

International Auto Buggy Specifications—Body—Piano box style, two seats or one seat, with top or without. Motor—2 cylinders opposed, 4-cycle, 5" x 5". Horse Power—14 by brake test, equivalent to 18 to 20 in automobile rating. Suspension—Power plant suspended on steel sub-frame under the body, with an equal distribution of weight. Transmission—Two speeds forward, one reverse, all operated by one lever. Drive—Chain to countershaft. Wheels—40-inch front, 44-inch rear with 1 3/4-inch flat tread solid rubber tires. Springs—36-inch full elliptic. Brakes—Internal expanding. Capacity—Four passengers, or 800 pounds freight when rear seat is removed. Speed—2 to 20 miles per hour. Accessibility—Engine is so situated that all parts are accessible from above.

Write for International Auto Buggy Catalogue

INTERNATIONAL HARVESTER COMPANY OF AMERICA (INCORPORATED)
100 Harvester Building CHICAGO, U. S. A.

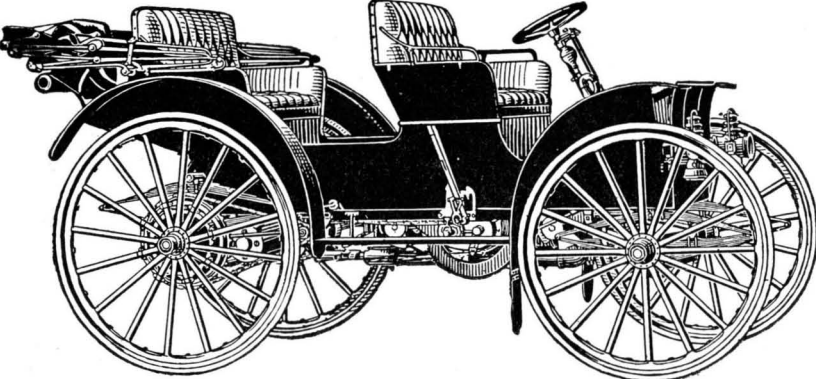

\$3.50 A Backus Water Motor

For Polishing, Grinding, and Power

Can be screwed on any faucet

BACKUS WATER MOTOR CO., Newark, N. J.

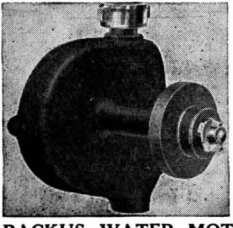

Buy a Battery That's Guaranteed

Our experience and our guarantee makes you safe in selecting the **The Hubler-Dayton Storage Battery**. It gives a strong reliable current of steady voltage, that gives perfect results for igniting and lighting your motor boat, auto or gas engine. No other battery made so carefully or with such high-grade materials as this. We also make the famous Apple Automatic Sparker that keeps your storage batteries charged, right on your boat, or auto. Also maintains electric lights. Our catalog tells more about them. You owe it to yourself to have this book. Write for it to-day.

THE DAYTON ELECTRIC MFG. CO.
98 St. Clair Street, Dayton, Ohio



10 DAYS FREE TRIAL "RANGER" BICYCLE on approval, freight prepaid to any place in the United States without a cent deposit in advance, and allow ten days free trial from the day you receive it. If it does not suit you in every way and is not all or more than we claim for it and a better bicycle than you can get anywhere else regardless of price, or if for any reason whatever you do not wish to keep it, ship it back to us at our expense for freight and you will not be out one cent.

LOW FACTORY PRICES We sell the highest grade bicycles direct from factory to rider at lower prices than any other house. We save you \$10 to \$25; middlemen's profit on every bicycle—highest grade models with Puncture-Proof tires, Imported Roller chains, pedals, etc., at prices no higher than cheap mail order bicycles; also reliable medium grade models at unheard of low prices.

RIDER AGENTS WANTED in each town and district to ride and exhibit a sample 1909 Ranger Bicycle furnished by us. You will be astonished at the wonderful low prices and the liberal propositions and special offers we will give on the first 1909 sample going to your town. Write at once for our special offer.

DO NOT BUY a bicycle or a pair of tires from anyone at any price until you receive our catalogue and learn our low prices and liberal terms. **BICYCLE DEALERS:** you can sell our bicycles under your own name plate at double our prices. Orders filled the day received.

SECOND HAND BICYCLES—a limited number taken in trade by our Chicago retail stores will be closed out at once, at \$3 to \$8 each. Descriptive bargain list mailed free.

TIRES, COASTER BRAKES, everything in the bicycle line at half the usual prices.

DO NOT WAIT but write today for our Large Catalog beautifully illustrated and containing a great fund of interesting matter and useful information. It only costs a postal to get everything. Write it now.

MEAD CYCLE COMPANY, Dept. L-175 CHICAGO, ILL.



1909 Model "G" Special 45 H.P.

Glide You Get Not What You Pay—is the Basis of Automobile Values

When you feel wealthy or charitable, pay \$4,000 or \$5,000 for an automobile no better than the GLIDE.

When you approach the automobile buying problem as you would any other business investment, pay \$2,250 for a GLIDE Roadster or \$1,900 for a GLIDE Touring Car. The only difference in the two transactions will be, that you have a good car and a couple of extra thousand dollars in your pocket.

If it pleases you to make some automobile manufacturer a present of \$2,000 or \$3,000, do so, and change your mind next season. Every GLIDE agent knows that his strongest competition comes from cars which have the same features as the GLIDE Roadster and Touring Car, and which sell at from \$2,000 to \$3,000 more than any GLIDE Model.

The GLIDE is the first car perfect in size, in mechanism, and in action that has ever been offered to the public at a correct price.

Many years of automobile building are back of every GLIDE. Years of fruitful experience that have added to the merits and popularity of GLIDE Cars.

The power plant is a 4-cylinder (cast separately) 45 actual H.P. motor. The crank shaft has 5 bearings, not 2 or 3.

A constant level oiling system, eliminating piping and automatically maintaining the proper level of oil in the crank case at all times.

An improved form of selective type of transmission, located just forward of the rear axle, reducing the angularity of the propeller shaft.

A rear axle with liberally proportioned parts, and of a construction that gives an absolute assurance of perfect work.

A multiple disk clutch with disks of large diameter.

Double set of brakes—internal expanding and external contracting. Brake drums are 16 inches in diameter, 3-inch face—will hold the car on a mountain grade. Absolute confidence in ability to slow down or halt at will is established when GLIDE brake equipment is examined. No brake system on any American or Foreign car has ever before been so comprehensively treated.

One Universal Joint only in GLIDE cars, located between the motor and the transmission. Remember, there are not two Joints or three Joints, or even four, as in other constructions.

Timken Roller Bearings throughout, all gears of the best Alloy Steel.

34 x 4 1/2-in. tires all around—Wheel base 120 inches. Remember, tires are all alike, not 34 x 4-in. in front and 34 x 4 1/2-in. in the rear, thus obviating the ridiculous necessity of carrying two sizes of spare castings and tubes.

The GLIDE is not an assembled car. It is built in our own shops, the motor excepted.

There is no more graceful car made. Its appearance suggests strength, capability and that quiet purposeful performance which give it the name—GLIDE.

If you are seeking a standard car of the best type, and at a price that is right, our catalogue, containing much detailed information, will be of considerable interest to you. Write today.

The Bartholomew Company
Standard Manufacturers A. M. C. M. A.
603 Glide St., Peoria, Ill.

Glide Roadster Model "R"—same chassis—wheel base 106 in.—36x4-in. tires all around, with either close coupled body seating four or Runabout body seating two—\$2,250.



COOPER'S
Spring Needle Knit UNDERWEAR

Cooper's is the original and only genuine "Spring Needle Knit" Underwear. You will probably have many other kinds shown you, but if you will examine Cooper's closely you will promptly decide in its favor. It is the most elastic, comfortable and durable underwear made.

The importance of thorough workmanship in underwear for men should not be overlooked. There are no imperfections in Cooper's. The wonderful Spring Needle fabric is flawless, and in addition each garment is stayed at points of strain, rendering it strong, sightly and serviceable.

Try Cooper's. It is the Underwear of character and quality.

Made in Union suits and two-piece suits in all sizes, weights and colors. Ask to see our new silk lises. Get the genuine.

COOPER MFG. CO., Bennington, Vt.



Great Power - Small Cost No Risk

Buy a powerful engine that is durable, economical and absolutely safe.

Waterloo Gas Engines

develop the full rated horse power and more. They are guaranteed for five years at any kind of work, never shut down for repairs, are absolutely simple in operation, and all sizes furnish the cheapest power for every purpose. Best for machinists, miners, millers, manufacturers, printers, farmers—for drilling, pumping, running air, compressors, dynamos, etc. Sold on credit if desired. Write today for Free Encyclopedia of engine facts.

Waterloo Gasoline Engine Company,
190 West Third Ave., Waterloo, - Iowa. 5 Year Guarantee



The Buggyaut gives 4-cylinder results with 2-cylinder cost and simplicity. Is air-cooled, 2-cycle and up-to-date. \$650.

CHAS. S. DURYEA, Reading, Pa.



Engineering News
(ILLUSTRATED)

The Leading Engineering Paper of the World. For Civil, Mechanical, Mining and Electrical Engineers 100 to 125 pages, 9" x 13", weekly. Send ten cents for sample copy.

If you cannot locate desired engineering equipment write our "Readers Want" department.

THE ENGINEERING NEWS PUBLISHING CO 214 Broadway, New York

HELMET OIL LUBRICATES SEND FOR ANYTHING FREE 13-21 S. CLINTON ST. CHICAGO, ILL. U.S.A.

