

SCIENTIFIC AMERICAN

[Entered at the Post Office of New York, N. Y. as Second Class matter.]

A WEEKLY JOURNAL OF PRACTICAL INFORMATION, ART, SCIENCE, MECHANICS, CHEMISTRY, AND MANUFACTURES.

Vol. LXXVI.—No. 14.
ESTABLISHED 1845.

NEW YORK, APRIL 3, 1897.

[\$3.00 A YEAR.
WEEKLY.]



TRUNK MEASUREMENT.

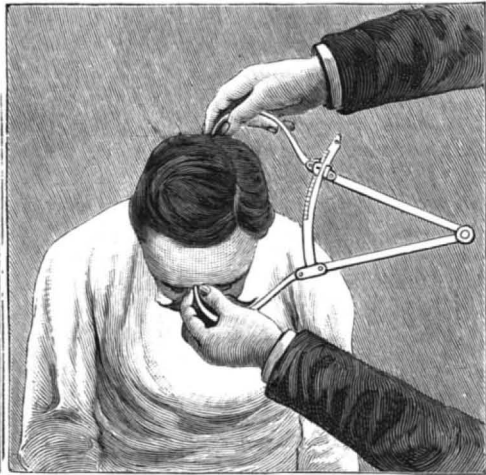

HEAD LENGTH MEASUREMENT.

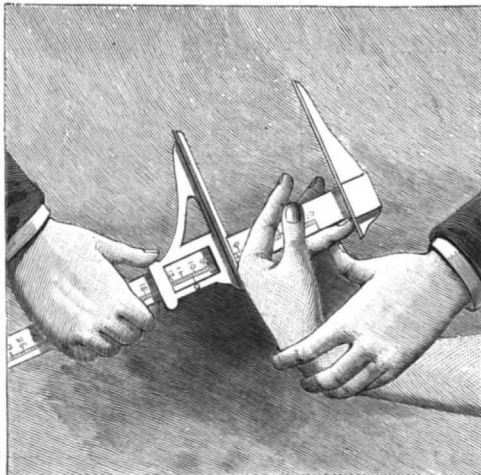

LEFT MIDDLE FINGER MEASUREMENT.

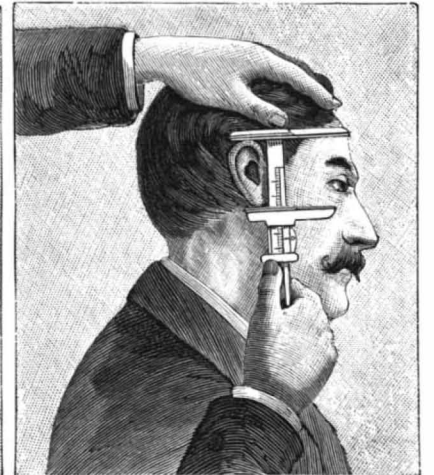

RIGHT EAR MEASUREMENT.



MEASUREMENT OF THE STRETCH AND THE LEFT FOOT.

THE BERTILLON SYSTEM OF IDENTIFICATION BY MEASUREMENT.—[See page 214.]

Scientific American.

ESTABLISHED 1845.

MUNN & CO., - - - EDITORS AND PROPRIETORS.

PUBLISHED WEEKLY AT

No. 361 BROADWAY, - - - NEW YORK.

TERMS FOR THE SCIENTIFIC AMERICAN.

(Established 1845.)

One copy, one year, for the U. S., Canada or Mexico, \$3.00
 One copy, six months, for the U. S., Canada or Mexico, 1.50
 One copy, one year, to any foreign country, postage prepaid, \$4.00
 Remit by postal or express money order, or by bank draft or check.
 MUNN & CO., 361 Broadway, corner Franklin Street, New York.

The Scientific American Supplement

(Established 1876)

Is a distinct paper from the SCIENTIFIC AMERICAN. THE SUPPLEMENT is issued weekly. Every number contains 16 octavo pages, uniform in size with SCIENTIFIC AMERICAN. Terms of subscription for SUPPLEMENT, \$5.00 a year, for the U. S., Canada or Mexico, \$6.00 a year, or £1 4s. 8d., to foreign countries belonging to the Postal Union. Single copies 10 cents. Sold by all newsdealers throughout the country. See prospectus, last page.
Combined Rates.—The SCIENTIFIC AMERICAN and SUPPLEMENT will be sent for one year, to one address in U. S., Canada or Mexico, on receipt of seven dollars. To foreign countries, eight dollars and fifty cents a year, or £1 1s. 11d., postage prepaid.

Building Edition of Scientific American.

(Established 1855.)

THE BUILDING EDITION OF THE SCIENTIFIC AMERICAN is a large and splendidly illustrated periodical, issued monthly, containing floor plans and perspective views pertaining to modern architecture. Each number is illustrated with beautiful plates, showing desirable dwellings, public buildings and architectural work in great variety. To architects, builders, and all who contemplate building this work is invaluable.
 Single copies 25 cents. By mail, to any part of the United States, Canada or Mexico, \$2.50 a year. To foreign countries, \$3.00 a year, or £0 12s. 4d. Combined rate for BUILDING EDITION with SCIENTIFIC AMERICAN, to one address, \$5.00 a year. To foreign countries, \$6.50 a year, or £1 6s. 9d. Combined rate for BUILDING EDITION, SCIENTIFIC AMERICAN, and SUPPLEMENT, \$9.00 a year. To foreign countries, \$11.00 a year, or £2 5s. 2d., postage prepaid.

Export Edition of the Scientific American

(Established 1878)

with which is incorporated "LA AMERICA CIENTIFICA E INDUSTRIAL," or Spanish edition of the SCIENTIFIC AMERICAN, published monthly, uniform in size and typography with the SCIENTIFIC AMERICAN. Every number contains about 100 pages, profusely illustrated. It is the finest scientific industrial export paper published. It circulates throughout Cuba, the West Indies, Mexico, Central and South America, Spain and Spanish possessions—wherever the Spanish language is spoken. THE SCIENTIFIC AMERICAN EXPORT EDITION has a large guaranteed circulation in all commercial places throughout the world. \$3.00 a year, or £0 12s. 4d., postage paid to any part of the world. Single copies, 25 cents.

MUNN & CO., Publishers, 361 Broadway, New York.
 The safest way to remit is by postal order, express money order, draft or bank check. Make all remittances payable to order of MUNN & CO.

Readers are specially requested to notify the publishers in case of any failure, delay, or irregularity in receipt of papers.

NEW YORK, SATURDAY, APRIL 3, 1897.

Contents.

(Illustrated articles are marked with an asterisk.)

Archæological news.....	215	Manna of the desert.....	212
Bertillon system of identification*.....	209	Oath, the Hippocratic.....	218
Boiler, Barnes.....	212	Paints, ready mixed*.....	212
Books, new, etc.....	219	Patent statutes amendments.....	210
Cement for glass (7138).....	221	Patents granted, weekly record of.....	220
Cold, degrees of (7135).....	220	Photographs, luminous.....	215
Columbia River scenery*.....	213	Printing press, a fast*.....	216
Die head, an improved*.....	212	Salt, the craving for.....	213
Diphtheria in cold and hot countries.....	211	Science notes.....	215
Electroplating (7141).....	220	Sewing machine ripper, Batchelor's*.....	218
Exhibition, the Stockholm.....	213	Steam engine, rotary*.....	211
Fire escape, Hennessey's*.....	218	Teaching, laws of.....	218
Glaciers of Greenland, the*.....	216	Trolley, underground, New York.....	210
Identification of individuals*.....	219	Water, some uses of.....	215
Invention, a \$50,000*.....	218	Wax, grafting (7139).....	220
Inventions recently patented.....	219	Work, quick.....	218

TABLE OF CONTENTS OF Scientific American Supplement

No. 1109.

For the Week Ending April 3, 1897.

Price 10 cents. For sale by all newsdealers.

	PAGE
I. ASTRONOMY.—Story of a Celestial Wanderer.—An article by Miss MARY PROCTOR.....	17724
II. BACTERIOLOGY.—The Bacteriology of Milk.....	17725
III. DYEING.—Easter Egg Dyes.—Formulas.....	17734
IV. EDUCATION.—Technical Education in Europe.—By C. P. BROOKS.—First installment of an important paper.....	17732
V. ELECTRICITY.—Watt and the Measurement of Power.—By WILLIAM HENRY PREECE.—An interesting and important paper by a very prominent electrician.....	17727
Positions of the Magnetic Poles.....	17731
VI. EXPLOSIVES.—Tetra-Nitro-Cellulose.—A new explosive.—By H. N. WARREN.....	17725
VII. MECHANICAL ENGINEERING.—Rotary Pumps and Engines.—Their origin and later development.—An important paper giving a historical resume of the rotary pump from 1588 on, illustrated with clear drawings showing the construction of various forms of pumps and engines.—9 illustrations.....	17728
Gas and Gasoline Motors.—A description of the Lair-Delay gas motor.—6 illustrations.....	17730
VIII. METALLURGY.—Note on the Inter-diffusibility of Metals.....	17730
IX. MISCELLANEOUS.—A Convenient Reading Table for Students.—A description of a curious revolving reading desk.—1 illustration.....	17731
The History of the Mirror.....	17731
Engineering Notes.....	17733
Electrical Notes.....	17733
Miscellaneous Notes.....	17733
Selected Formulae.....	17734
X. NATURAL HISTORY.—The Problem of Instinct.—By ALFRED R. WALLACE.—A most important study by a naturalist of great reputation.....	17724
Playfulness of Young Tigers.—1 illustration.....	17722
XI. RAILWAYS.—A Single Rail Railway.—A description of the Calletet single railway in which the cars are propelled either by horses or by hand power.—7 illustrations.....	17726
XII.—TECHNOLOGY.—The Action of Oil on India Rubber.....	17734
XIII.—TRAVEL AND EXPLORATION.—The Insurrection in Crete.—A graphic account of the exciting times in Crete by a correspondent in Athens.—Fully illustrated with portraits and views of Crete.—7 illustrations.....	17719
The Catacombs of Paris.—A description of the ossuary underneath Paris.....	17723

SECTION SEVEN OF THE AMENDMENTS TO THE PATENT STATUTES.

In a recent issue we commented editorially upon a bill embodying certain amendments to the patent statutes of the United States which had been signed by the retiring President in the closing hours of his administration. Our readers may or may not have noticed that, although we discussed the provisions of each amendment in detail, we were careful to place by itself, and publish without any comment, a certain section 7 which reads as follows:

"That in every case where the head of any department of the government shall request the Commissioner of Patents to expedite consideration of an application for a patent, it shall be the duty of such head of a department to be represented before the Commissioner, in order to prevent the improper issue of a patent."

Our silence with regard to this section was due to a reluctance to make any criticisms which might have been based upon a misconception of its real scope and purpose; for we are free to confess that at the first reading it appeared to be a most foolish, ill-considered, and unnecessary measure.

We eagerly sought for enlightenment as to the interpretation of this measure, being unable to grasp its full meaning ourselves. We were unable to obtain any explanation of the meaning of the amendment at the Patent Office; the chairman of the committee which formulated the original bill was no better informed, and we were finally referred to the author of the section in question. Briefly stated, it provides that where the head of a department undertakes to hasten a decision upon a patent application, he shall also take upon himself the responsibility of seeing that the Commissioner of Patents does his duty and does not issue the patent improperly. As it has been explained by the author of the amendment, "He (i. e., the head of a department) should be represented by his law officer or otherwise, as he may choose, in order to prevent the improper issue of a patent which, being issued, may become a burden upon the government."

While we are satisfied that this amendment was drawn up with the best of intentions and a desire to protect the interest of the country at large, we think it possesses features which are strongly objectionable and which have probably been overlooked in the haste with which the bill was finally pushed through.

The amendment certainly seems to take the form of a vote of lack of confidence in the Commissioner of Patents and the work of the Patent Office. If the Commissioner of Patents is not qualified to prevent "the improper issue of a patent," who is? And, if he is not so qualified, it must be either because of his incapacity or partiality. If he is incapable of judging what is proper or improper in his own department, are we to suppose that the head of some other department or his irresponsible clerk would be more capable?

There is a further objection to the amendment in the fact that it places the head of a department in the anomalous position of being plaintiff and defendant at one and the same time. In one breath, as a supposed friend of the case, he urges that it be taken up for consideration, and in the next he is instructed to put obstacles in the way of the grant of a patent. The application is no longer a matter to be determined between the client's attorney and the Commissioner; but it must be argued in a triangular fashion between the attorney, the Commissioner, and a third somebody, whose claim to standing in the case is the fact that he has asked for its early consideration, and is there "to prevent the improper issue of the patent."

To appreciate this amendment at its full value, one has only to consider the history of the bill up to the time when section 7 was added. The bill was drawn up by a committee of the highest authorities and most distinguished practitioners of patent law—a branch of the law, be it said, which is admitted to be particularly complex and abstruse. The amendments carried the sanction of the American Bar Association, and they were only drawn up in their final form after extensive correspondence with patent solicitors and others specially learned in this branch of law. They then received the careful consideration of the House committee; were passed by the House, and forwarded in due course to the Senate. Here, at the eleventh hour, without the knowledge of the gentlemen of the bar who formulated the bill originally and without consultation with any who were likely to possess any special knowledge of such matters, this amendment was inserted, and the friends of the bill deemed it wisest to accept the amendment in order to avoid the defeat of the whole bill.

Looked at from any point of view, it is difficult to see what good this amendment can work to the government or to anyone else. It is certainly advisable that the heads of departments should be kept well advised as to the progress of invention in those fields with which the government is especially concerned; and it has been the custom of inventors to seek the advice of heads of department and their aid in hastening the hearing of such patent applications as might affect the interests of the various departments. In this respect, as far as it legitimately could do so, the government

stood as the friend of the inventor and would-be patentee.

Section 7 of the amendments, however, will change all this at a stroke, and inventors will in the future hesitate to disclose their plans to heads of departments who, if they considered that a patent would "impose a burden upon the government," would use every effort to secure its defeat.

THE UNDERGROUND TROLLEY IN NEW YORK CITY.

The street railroad commission of New York has granted the application of the Metropolitan Traction Company to operate its lines by the underground trolley system—a change which will affect some forty miles of railroad lines in New York City.

It is a well known fact that the problem of transportation in New York presents special difficulties which arise from the nature of the site upon which the city is built. All the elevated and surface systems of transportation run mainly in parallel lines from north to south along the full length of the island. By far the greater part of the travel is in a north and south direction, and although the different arteries of travel lie but a block distant from one another, there is at all times of the day more or less crowding, and during the "rush" hours the congestion is attended with great discomfort and more or less delay. As the important change which is contemplated by the Metropolitan Traction Company is directed primarily to relieving the traffic upon the Broadway cable road, the lines which are to be electrically equipped are those which lie immediately to the east and the west of this road, and extend from the Harlem River south through the whole length of Manhattan Island.

The present Eighth Avenue horse car line will be equipped throughout with the new system. Commencing at the Harlem River, the new line will run on this avenue to Fifty-ninth Street, where there will be a cross line of the same construction from First to Tenth Avenue. From Fifty-ninth Street the new line will continue on Eighth Avenue over the present route to a terminus at Canal Street and Broadway. Another branch will start from Fifty-ninth Street and run down Sixth Avenue to West Broadway. At Fulton Street it will be carried east to Church Street, and through Church Street to a terminus in Battery Place. The company has announced that the first part of the work to be undertaken will be the Sixth and Eighth Avenue lines below Fifty-ninth Street, and it is expected that they will be in running order by the middle of the autumn. The company intends to put in the same system on the Fourth and Madison Avenue line, which runs from the Harlem River to the Post Office. It will also construct a line on Amsterdam Avenue, from Manhattan Avenue to Sixty-fifth Street and through Sixty-fifth Street to Eighth Avenue.

It will be seen that the proposed system will give a greatly improved service between the northern and southern portions of the city. It will give a parallel service on each side of Broadway which cannot fail to relieve the congestion, especially in the lower city. The cross line at Fifty-ninth Street will very materially contribute to the convenience of cross town travel, inasmuch as passengers from Amsterdam Avenue and Eighth Avenue can cross over to Madison Avenue and continue down on the east side of the city, and on the other hand, passengers from the Harlem district over the Madison Avenue line can cross over at Fifty-ninth Street and continue down Sixth or Eighth Avenues to the shopping district, both of which journeys can be accomplished without change of car.

It is the intention of the company to push the work through with all possible dispatch, and have the whole forty miles of line in operation before the close of the year. If they succeed in doing this, it will rank as one of the most remarkable feats of railway construction on record of any kind, and will be entirely without a parallel in the records of street railway construction. The managers of the company claim that they will be able to build at this high rate of construction because of the comparative simplicity of the construction and the enormous force of men which they will crowd upon each section of the work.

It will be known to many of our readers that the Metropolitan Traction Company has been operating for some time several miles of underground trolley system on a branch known as the Lenox Avenue line. This was built largely for experimental purposes, and the designs for the present proposed extensions have been based upon the experience which has been gained in this way.

In its broad features the construction will be similar to the one mentioned, which was fully illustrated in the SCIENTIFIC AMERICAN for February 22, 1896. The main features of the new system are as follows: The conduit, which is placed in the center of the track, carries two conductors, one for the supply and one for the return current. It will be shallower than the one on Lenox Avenue, and from the interior of the conduit an open passageway, about 5 inches in width, will connect with the street surface and will be closed with the customary slot rails, leaving a narrow opening for the plow. The iron conductors will be of a T-shaped cross section

and will be placed about six inches apart. They will be carried on every third yoke, and the yokes will only be about 70 per cent of the weight of those on Lenox Avenue line. The rails will be of the Crimmins type, which is designed to reduce the injurious effects from the wheels of street traffic. They will be exceptionally heavy, weighing no less than one hundred and seven pounds per yard, which is seven pounds heavier than the heaviest rail at present used on the trunk railroads of the country.

The estimated cost of the new lines completely equipped is between \$6,000,000 and \$7,000,000.

THE "ROTARY" STEAM ENGINE.

BY PROF. R. H. THURSTON, CORNELL UNIVERSITY.

The "rotary" steam engine, as it has been for a century called, is one of those seductive classes of mechanism which have been tantalizing the inventor and engineer for generations. From the time of James Watt, who a century and a half ago, nearly, devised this form of engine, it has been continually coming forward in shapes various, new and old, only to disappear promptly on being put to the test of daily operation under conditions permitting its exact performance to be ascertained. In Watt's patent of 1769, in its fifth claim, we read:

"5thly—Where motions round an axis are required, I make the steam vessels in form of hollow rings or circular channels, with proper inlets and outlets for the steam, mounted on horizontal axles, like the wheels of a water mill. Within are placed a number of valves that suffer any body to go round the channel in one direction only. In these steam vessels are placed weights, so fitted to them as to fill up part or portion of their channels, and yet capable of moving freely in them by the means hereinafter mentioned or specified. When the steam is admitted in these engines between these weights and the valves, it acts equal on both, and so as to raise the weight on one side of the wheel, and, by the reaction of the valves successively, to give a circular motion to the wheel, the valves opening in the direction in which the weights are pressed, but not in the contrary."

But far back of the days of James Watt are found the originals, the prototypes of the most successful of recent forms of rotary engines, of the steam turbines. Hero, of Alexandria, a century and more before the Christian era, published descriptions of the reaction steam wheel, and gave drawings showing its form and method of action. In 1629 Branca described the companion form, the "impact" steam turbine, which is to-day a favorite and successful machine in certain fields of work.*

Since the beginning of the century thousands of inventors have attacked the problem, and hundreds of such inventions have been made, not one of which has been successful in competition with the reciprocating engine in its own wide field. The steam turbines are coming into use in the special field of high speed machinery, mainly in driving electric machinery. Here, too, it is only the simplest of all these forms, and the most ancient of types, which are in any sense successful. The steam turbines seem to have come to stay. For this there exist interesting and special reasons, both theoretical and practical. The reasons for the failure of rotary engines as a class is a marked feature of the century of growth of the steam engine. Those reasons are readily discovered, as we shall presently see.

In the accompanying issue of the SCIENTIFIC AMERICAN SUPPLEMENT † will be found an historical review of the inventions of this class of engines, and its illustrations include practically every class of machine of this type yet produced, and even among these many resemblances will be noted, closely relating one to another. It will be seen that all come into one or another of these classes: (1) the simple system of gearing without valves, of which the now well known Holly engine and pump are typical examples; (2) the system in which the steam chamber revolves, and work is performed by reaction in a manner first investigated by Sir Isaac Newton; (3) the system in which the issuing jet of steam impinges upon the vanes of a revolving "steam wheel;" (4) that in which a rotary motion is given a wheel having fixed vanes, or some equivalent, by introducing sliding abutments and valves between which and the vanes of the wheel steam may be introduced and there may expand; (5) revolving wheels or disks, set eccentrically with the cylindrical casing, in such manner that sliding vanes, passing into and out of the wheel, may intercept the steam and compel it to act in such a way as to force the disk to turn. A wonderfully interesting collection, illustrating the ingenuity of the mechanic and inventor in a remarkable manner, is shown in the historical article referred to, and our readers will do well to study it minutely.

The claims made by inventors of the rotary engine

* "History of the Growth of the Steam Engine." R. H. Thurston. "International Series." New York, London and Paris. Pp. 8, 17, 100.

† The first of a series of articles upon the history, peculiarities and defects of the rotary engine will be found in this week's issue of the SCIENTIFIC AMERICAN SUPPLEMENT, which article will be continued in the two issues following.—Ed.

usually are that it is superior to the reciprocating machine in simplicity, in its lower cost, its greater compactness, its less volume and weight as well, and, sometimes, that it is more economical of fuel. The latter claim need not be here discussed further than to say that it has no foundation in any case known to us. Fabulous claims are often advanced relative to the reduction of weight and volume effected by the use of these machines, and these are sustained in the case of the steam turbine, of whatever form; as its enormous speed of best effect permits corresponding reduction of size for a stated power. The other forms have not yet proved superior to the now common high speed engine; which, in fact, has probably attained a higher speed than is usual with the rotary engines. For many years, a small engine, designed by Captain Ericsson, was in

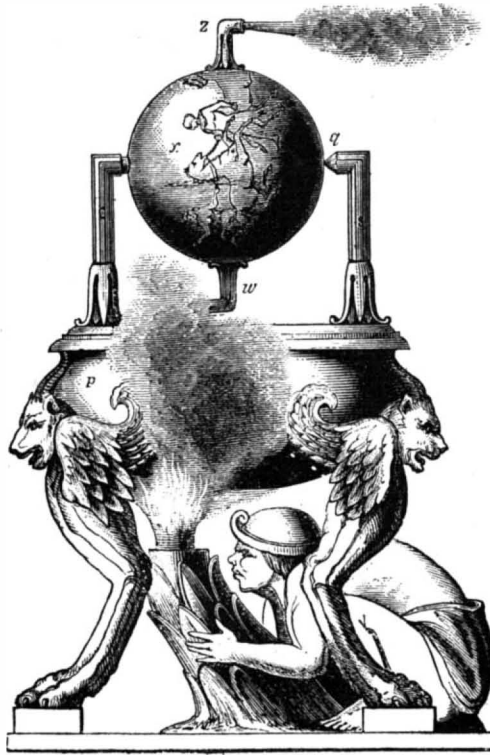

THE GRECIAN IDEA OF HERO'S STEAM ENGINE.
120 B. C.

operation at the Delamater Iron Works, in this city, driving an electric lighting system, one of the earliest ever installed, and was regularly speeded at 1,250 revolutions a minute.* The Brotherhood, a balanced reciprocating engine, is said to have been experimentally driven up to 2,700 revolutions a minute; but the steam turbines range between 5,000 and 20,000 with varying sizes, the smallest having, of course, the highest speed.

The essential, economical and practical characteristics of a thoroughly good steam engine to-day are: (1) Regular speed; (2) economy in the use of steam; (3) inexpensive construction; (4) compactness and lightness; with which qualities must always be combined safety in operation. The best modern reciprocating engines regulate to a degree of nicety which is quite wonderful. One firm of American builders guarantees a high speed engine, not to vary one revolution a minute from its rated speed, and the introduction of the later forms of shaft governor, with their peculiar "inertia effects," has made regulation practically perfect. The best contemporary construction of mill engine, with its high steam and multiple cylinder arrange-

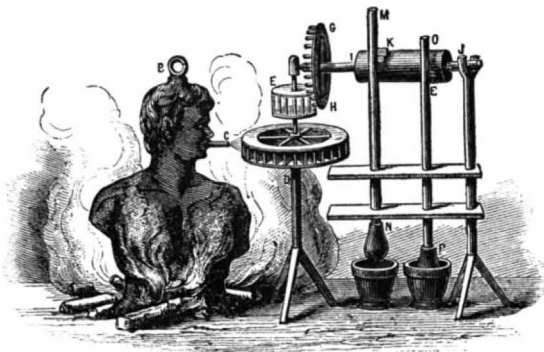

BRANCA'S STEAM TURBINE, A. D. 1629.

ment, has brought down the consumption of steam to 12 pounds per horse power per hour. The costs of construction have become not far from \$10 per horse power for such engines as are supplied our light and power stations. The weights of reciprocating steam engines have been brought down from the half ton of a half century ago, per horse power, to one-tenth that figure ordinarily; and in marine, and especially torpedo boat construction, to one-twentieth and even less; while the aeronauts are building, as in the cases of Maxim and of Langley, steam engines lighter for their power than the swiftest birds that Nature has produced in her ages of steady evolution. Six pounds per horse power is now regarded by these inventors as a heavy weight for their

* "Stationary Steam Engines for Electric Lighting." New York: J. Wiley & Sons.

work. The birds weigh 25 to 50 pounds and sometimes more, as computed by the best authorities to date.

In all these respects the rotary engine has usually failed to satisfy the market up to the present time, and it would seem that the mechanical and kinematic possibilities have been fully exhausted in the endeavor to solve the problem in this way. No perfect regulation of the rotary engine has been made integral with either of the constructions illustrated by us; no rotary has reduced the cost of power in steam consumed below the figures attained by even the ordinary reciprocating machine; none has attained a higher maximum speed, the turbines excepted; none has been proved to have inherent possibilities of giving out power in larger proportion of work performed to weight or cost of the machine, when placed in competition with the reciprocating engine of similar commercial class.

The inherent difficulties meeting the inventor in this field are principally those of securing satisfactory regulation and especially of attaining a satisfactory economy of steam and fuel. A variable cutoff, adjustable by the governor, seems to be the essential feature productive of both economy and steady speed, and this has not been realized in such manner as to satisfy the market in this class of engines. Further, it seems practically impossible to avoid serious wastes by leakage in these engines, after a little wear, however carefully the machine may have been originally constructed. It soon loses its tightness, and steam pours past its valves and abutments.

The steam turbines, however, must be set apart from the other rotary engines, as possessing some peculiar and promising features, especially in respect to wastes of heat and steam. The common forms of steam engine waste enormously, especially in their smaller sizes, by the condensation of steam, at entrance, by the then comparatively cold cylinder wall, which is continually alternately heated and cooled by the prime steam and the exhaust. This fluctuation of temperature of the metal and of the water which is precipitated in the cylinder causes a waste of from twenty per cent, in the largest and best engines using dry steam, to fifty per cent, and often much more, of steam entering from the boiler; thus adding from twenty-five to one hundred per cent or more to the otherwise purely thermodynamic demand for steam and fuel. In the steam turbines, on the other hand, there is no such fluctuation of temperature of cylinder wall, and this machine is thus entirely free from the most serious, and often enormous, waste of the reciprocating engine. It is this fact which accounts for the remarkable economy often now attained with this class of engine, and once its speed is made satisfactory, or conveniently adaptable to ordinary machinery, it would seem that it might prove a formidable rival in many cases to the now standard forms of engine.*

Should this prove to be the fact, we shall have the singular and interesting spectacle of the world going back to the time of Hero, two thousand years, to find the simplest and cheapest and most economical of steam engines.

DIPHTHERIA IN COLD AND HOT COUNTRIES.

Dr. Schellong, of Königsberg, has recently published a valuable monograph in Virchow's Archiv on "Diphtheria in the Tropics." He admits the correctness of Trousseau's saying, that the disease in question is to be seen in all seasons and also in all climates. He shows, however, that this opinion is correct as far as mere distribution of the malady is concerned, but is otherwise misleading. Diphtheria is, in fact, very unusual in any tropical country, and when it occurs it is purely sporadic and always mild. Schellong has carefully investigated the sanitary records of low lying malarious plains in tropical islands and continents, but diphtheria has proved no more prevalent there than in high ground. The disease is very rare in the West Indies, Guiana, the coast of Brazil, tropical East and West Africa, Madagascar, Hindostan, and the Indian Archipelago. Hence dampness of the soil is not necessarily a cause of diphtheria, nor does it in any way promote its diffusion. It is not prevalent even in the poor districts of crowded tropical towns. On the other hand, it is frequent in the highland villages of Peru, and in subtropical districts and warm temperate climates—Havana, Jerusalem, Cairo, Santiago, Montevideo, the north of South Africa, and Brisbane, in Queensland. In temperate climates, south as well as north, it is almost universally distributed, the Cape, Adelaide, Sydney, Melbourne, Tasmania, New Zealand, and the south of Chile and Argentina being as little free from diphtheria as are the cities and villages of Europe, the United States, Japan, and northern China. As intense heat is experienced in summer in several of the places just mentioned, it would appear that perpetual heat is necessary to kill the germs of diphtheria, while a few weeks of cold keep it alive and allow the disease to be endemic even in Cairo and Brisbane. Schellong, who illustrates his monograph by means of a good chart, does not believe in racial immunity.—British Medical Journal.

*The theoretically best speed of orifice is infinity for the "Hero engine" and about 1,000 feet per second for the single wheel guide curve turbine.

THE MANUFACTURE OF READY MIXED PAINTS.

No one who is unacquainted with the manufacture of ready mixed paints has any idea of the great amount of time and care which are expended in the mere operation of mixing. At first sight it would seem as though the proper mixture of white pigment with linseed oil could be easily secured, and was a very simple mechanical operation. As a matter of fact, however, the process is long and tedious, and requires the construction of a large amount of heavy and costly machinery. The quality of a paint depends very largely upon the intimate mechanical mixture of the atoms of oil and pigment, and experience has proved that this can only be secured by many hours of manipulation in the various agitators and mills of a paint factory.

The accompanying illustration, which is a vertical section taken through the factory of the James E. Patton Company, of Milwaukee, will give the reader some idea of the construction in a modern paint works. The operations commence on the highest floor of the factory and are carried on continuously in machines which are placed on the succeeding floors, the contents being finally gathered in storage tanks on the lowest floor. The first machine is known as a chaser, and it is here that the dry white pigments and the linseed oil first come in contact. Pigments and linseed oil are placed in the right proportion in an apparatus which works somewhat on the same principle as a common mortar mill. Here they are worked up into a rather stiff paste, and as soon as the mixture has reached the proper consistency it is dropped into a mill which is built somewhat on the lines of an agitator. From this mill the material passes through double mills located on the ground floor into a final finishing mill. In passing through these machines the paint is ground to a remarkable fineness, and as it leaves the last mill sufficient linseed oil is added to the mixture to bring it into the proper state of consistency for the brush. The paint is then carried into long, horizontal steel reservoirs, inside of which are shafts which carry a number of steel propeller wheels, which serve to keep the paint in a continual state of agitation. As the thrust of the wheels is in the direction of the final outlet from the tanks, they drive the fluid in that direction. Below the storage tanks is a series of large cylindrical tanks into which the white liquid is drawn in the quantities required. Here it is tinted by mixing certain unvaria-

ble proportions of coloring pigment with it, each tank having, of course, its own color.

Centrally placed within each tank is a vertical shaft, to which are attached a number of agitators, the shaft being driven by means of bevel gearing from a horizontal shaft arranged above the tanks.

The liquid in the storage tanks is kept in a state of continual agitation until it is finally drawn off into barrels for shipment. The constant agitation is necessary,

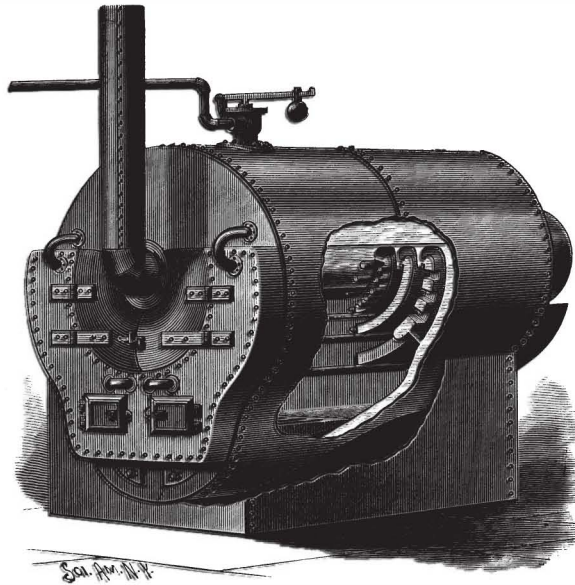

BARNES' BOILER.

of course, to prevent the solid pigment from settling in the tanks, and it serves to keep the liquid paint at the proper consistency.

Although the excellence of a paint depends largely upon the thoroughness with which the materials are ground and mixed, it is also determined largely by the quality and proportions of the pigments. It is a mistake to suppose, as many people do, that the body of all paints is formed of pure white lead. The product of the factory of which we are speaking consists of a mixture of lead with oxide of zinc or other unchangeable pigments, the long experience of the manufacturers having shown, it is claimed, that these constituents, in the proportions employed, give a paint which is more durable and one that holds its color better than a paint which is made from pure white lead.

A NEW AUTOMATIC SCREW CUTTING DIE HEAD.

A new automatic opening and adjustable screw cutting die head, for use on turret head and other screw machines, is represented in the accompanying illustration. It is especially designed for threading the ends of bicycle hubs, tubing cups, cones and other bicycle fittings, as well as other short threads of a similar nature, such as used on water, steam and plumbers' specialties. The die head is provided with a central stop or gage, which may be adjusted to the length of thread to be cut. When the work strikes this gage the threading dies fly open, releasing the thread, and the die head may be withdrawn. The die head is also provided with a graduated adjustment, being entirely independent of the opening movement, and by means of which the dies may be set for cutting the required size. The head proper and shank is made in one piece, thereby securing great strength and rigidity. The front of the head is provided with four cross slides which carry the threading dies; the threading dies of course being interchangeable for those of other sizes of threads or renewable when worn out. The cross slides are provided at the back with lugs projecting into eccentric slots in a spring-actuated cam, a partial revolution of which in one direction closes the dies, while a movement in the opposite direction throws them open. The spring which actuates the cam has one end fastened to a small collar held in position on the shank by small set screws, and is gaged to give sufficient tension at all times for opening the dies. The back plate has a slight movement endwise, but does not turn. Three screws in the hub of the back plate pass through the shank of the tool without touching it and serve to hold the gage in position. Two of the screws are fixed, while the third acts as an adjusting screw for varying the position of the gage. When the work

strikes the gage, the back plate is moved back enough to release the locking pin from the cam, which instantly flies around and the dies are opened. The locking pin passes through a circular slot in the back plate long enough to allow all necessary adjustment for the diameter of the screw. The index plate covers the slot, and by a pointer indicates the adjustment by graduations on the circumference of the back plate, the graduations being made to read by hundredths. The die head is closed by the small handle shown, and the dropping of the locking pin into the hole in the cam locks the dies securely. The die head may also be closed automatically by means of a pin screwed into a threaded hole opposite the handle, and attaching a taper piece to the tail stock or bed of the machine, which will engage the pin as the head is brought back. It will be seen that every part of the die head is most effectively protected from chips and dirt.

This die head is manufactured by the Geometric Drill Company, New Haven, Conn., who have established a wide reputation for the ingenious tools and high class of workmanship they produce, being especially identified with their patent system of geometric drilling and turning. They also have the distinction of making the smallest as well as the largest automatic screw-cutting die head for turret lathe use, as they furnish these tools for threading any size from No. 17 wire gage to 6 inches diameter inclusive.

AN IMPROVED BOILER.

The illustration represents a boiler in which a series of segmental and longitudinal water legs form passages or channels for the products of combustion, the channels being connected together alternately at opposite ends of the boiler, whereby the products of combustion are caused to traverse the channels consecutively. The improvement has been patented by Thomas Barnes, of Vancouver, Canada. An auxiliary shell is formed in its lower half with a water leg sufficiently depressed at its front end to afford room for the fire box, ash pit, etc., and the fire box at its rear end opens into channels formed by water legs, one of which extends about half way the length of the boiler, while the other extends from one head of the boiler to the other. There is a hood on the front end of the boiler into which the channels open, and on its rear end are two hoods, one above the other, the lower one being water jacketed and the upper one being held on the rear end of the shell, the hoods being preferably made in the shape of hinged segmental doors, so that they may be readily opened for conveniently cleaning the channels as well as the flues. The latter are somewhat less in diameter than the inside width of the corresponding water leg, so that each flue is completely surrounded by the water in the leg.

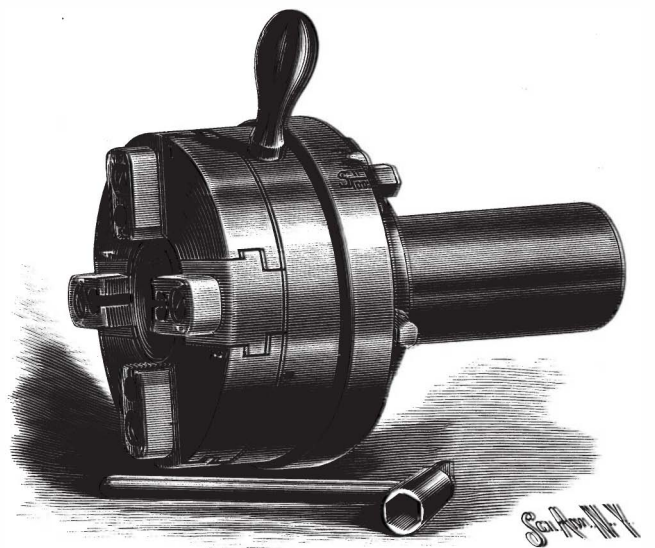

A NEW DIE HEAD.

When the hoods are closed, the smoke and gases from the fire box pass by the lower channels through the lower rear hood, then forwardly and through the front hood, and by other channels to the upper rear hood, from which they again pass forwardly by an upper channel and flue to the smokestack. The boiler is provided with suitable drain pipes and manholes, and is designed to utilize the heat generated to the fullest advantage.

The Manna of the Desert.

The manna sent to the Israelites on their journey out of Egypt to the Holy Land is regarded as identical with an edible lichen in Kerner and Oliver's "Natural History of Plants," and the older view that it was the sap of a tamarisk, exuded under the influence of a parasite, is held to be without foundation. Mr. M. J. Teesdale reviews the subject in the February number of Science Gossip, and the evidence he brings forward is opposed to the conclusion to which reference has been made. He shows that an exudation from the twigs of the tamarisk (*Tamarix gallica*) has more points of resemblance with the manna of the Israelites than either the edible lichen or the sweet gums exuded by leguminous shrubs, such as *Alhagi maurorum* or *A. desertorum*—both known to the Arabs as camel's thorn.

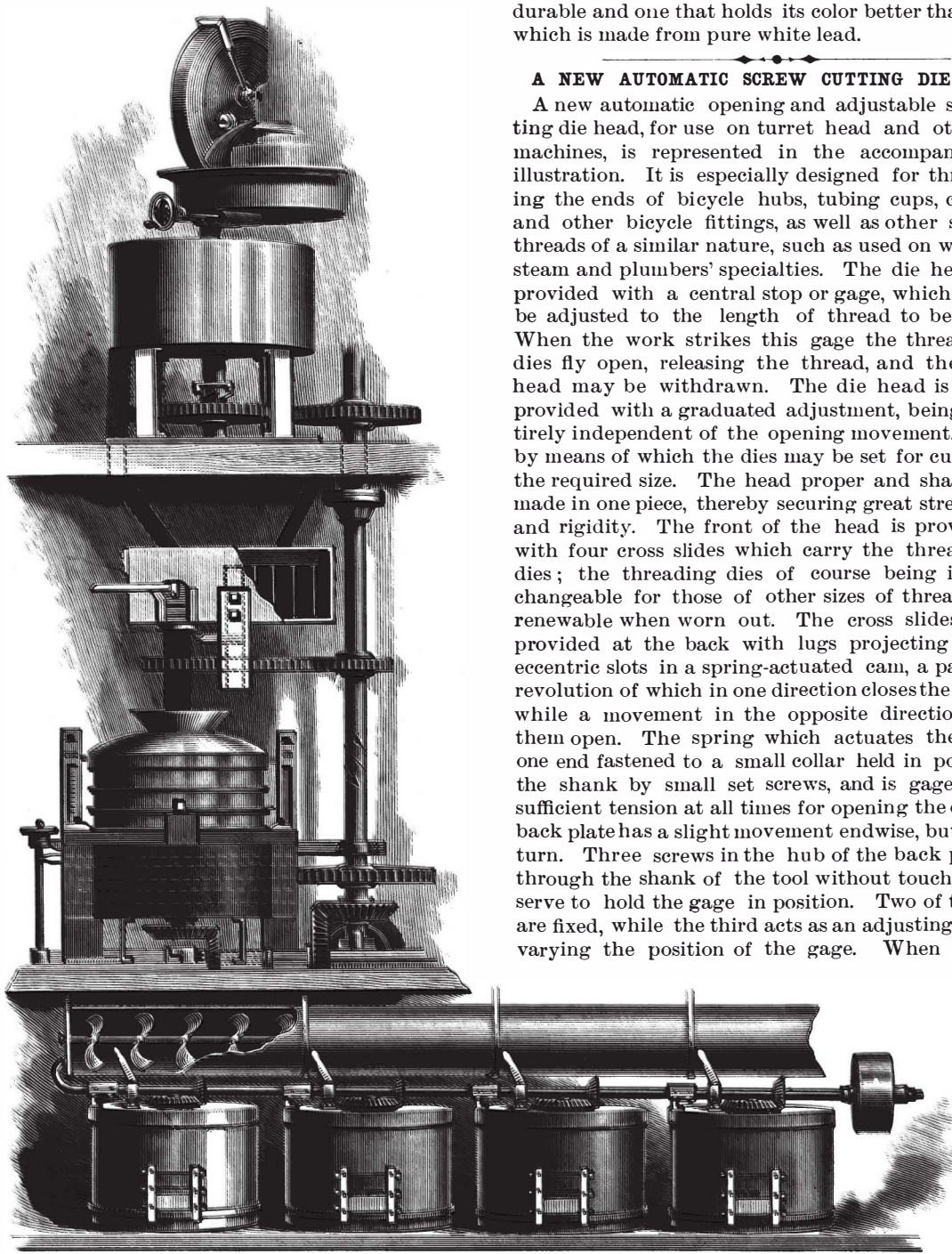

THE PATTON PAINT MILLS, MILWAUKEE, WIS.

SCENES ON THE COLUMBIA RIVER, OREGON.

We have been favored by Mr. H. H. Shank, of Hagerstown, Md., with the accompanying photographs and some notes of characteristic scenes on the Columbia River, Oregon, which were gathered during a recent tour in the far Western States.

The traveled American whose journeyings have not been confined to the Old World, but include (as they too seldom do) a tour among the natural wonders of his native land, is impressed with the inconsistency of those people who roam, year by year, among the mountains, lakes and rivers of Europe, and neglect the natural beauties of their native land. Majestic and impressive as the Alps may be, they do not lift their heads any more grandly than the summits of the Rockies, the Cascades or the Sierras; and nowhere are they clad with such a wealth of noble verdure as is spread about the base of our Western mountains. The Rhine may seem to sweep in stately fashion beneath beetling cliffs and hills that soar loftily above its waters, but in the presence of the awe-inspiring heights and depths and changing shadows of the "Gorge of the Columbia River," the Rhine becomes an insignificant memory, and the mind's sense of dimension is baffled in the effort to take in this infinitely greater, nobler and more majestically beautiful Rhine of our native land.

All too little known by the tourist is the land "where rolls the Oregon;" and those Eastern travelers who chance to spend a few weeks under its cloudless summer skies, where the atmosphere is so clear that mountain peaks which are over one hundred and fifty miles distant from the spectator stand out with clear cut profile, and on every side the eye roams easily over unwonted breadth and distance of landscape—such travelers experience a sense of novelty and change which the mere summer trip to Europe can never awaken.

"The Gorge of the Columbia" is the name given to a great natural rent in the wall of the Cascade Mountains, through which the Columbia River finds its way to the Pacific Ocean. In places the towering walls of rock rise for thousands of feet all but perpendicularly from the edge of the waters. Elsewhere the slope is more gradual and the inclination will be maintained with remarkable regularity from the shores of the river to an altitude of many thousands of feet. Elsewhere again the sides of the gorge are rent into fantastic and colossal shapes. Two of the most noted of these are shown in the accompanying illustration. They are situated on the Oregon or southern side of the river, and stand out apart from the parent cliffs in solitary grandeur, guarding, like a pair of giant-sentinels, the line of the Transcontinental Railroad that threads its way between them. On the very crest of the larger rock stands a solitary pine, secure from the woodman's ax. In some respects the journey by this railroad is one of the most picturesque in the world. It follows the tortuous course of the river through the gorge, finding a precarious footing between beetling cliff and foaming torrent, with the occasional variation of a long viaduct or "trestle" of timber to carry it across the bed of a mountain waterfall. Of the latter there are several, the most notable being Latourelle Falls, a few miles down the river, where a stream leaps over 400 feet from the overhanging precipice, and Multnomah Falls with its unbroken fall of 850 feet.

About sixteen miles below The Dalles, an important river shipping point for the produce of Eastern Oregon, is Memeluse Island, situated well out in the middle of the river. Memeluse is the Indian name for dead, and this island of the dead was formerly used by several of the local tribes as the last resting place for the bodies of their memeluse friends whose spirits had embarked for the happy hunting ground. The Indians do not inter their dead, but place the body upon a raised staging, upon which are also placed certain of the belongings of the deceased. It takes but a few years' exposure to the elements to reduce such a burial ground to the condition shown in this weird reproduction of the camera.

The Craving for Salt.

In a recent number of the Lancet the Paris correspondent writes that this subject was discussed at a recent meeting of the Société de Biologie. M. Lapicque stated that sodium chloride was consumed as an article of necessity by nearly all races, and that most of the lower animals were fond of it, although there were ex-

of the French Congo, between Lake Sangha and Lake Tchad. Salt was unknown in this vast territory, which was as large as France; for it was substituted an artificial salt extracted from a certain number of selected plants, whose ashes were washed and their potassium salts crystallized out.

Samples of the salt had been analyzed and found to be composed of potassium salts only. When, on their first entrance into the country, the French had endeavored to sell common salt they found it unsalable, the natives preferring their own. This disposed of the theory propounded by Bunge, and, the writer thought, weakened another theory advanced by Ringer and others, who maintained that potassium salts had the property of a protoplasmic poison and cardiac depressant.

M. Lapicque inclined to the belief that salt was of use only in procuring for man and animals a gustatory stimulus. M. Trouessart stated that dearth of salt in besieged cities had been made up by the use of saltpeter. M. Giard told his colleagues the story of the chimpanzee of the London Zoological Gardens, which, deprived of salt, had taken to drinking its own urine. As soon as it had been provided with a block of bay salt it had ceased to drink its urine, and used to sleep with the salt held tightly in its arms. According to M. Samson, oxen and sheep would, on large farms, abstain for weeks together from the salt placed within their reach, while at certain other periods they ate largely of it. This variability of appetite for salt was due to the variation, according to the season of the year, of their diet.

Stockholm Exhibition.

The Stockholm Exhibition of 1897 will comprise engineering, building industry, machinery, implements, transport, shipbuilding and navigation, electricity, fisheries, military science, sport, traveling, fine arts, education and instruction, hygiene, scientific appliances, etc. The site of the exhibition, according to Kuhlow's German Trade Review, is commodious and picturesque, and will include the Northern Museum and the Bostrom Villa. The exhibition buildings proper are numerous, and the more important are to be, it is said, very striking. The large hall for the industrial section occupies a good position on an elevated terrace, and it is claimed for it that it is one of the largest wooden structures ever built. The building will have a dome 300 feet high, surrounded by four turrets, of which some, if not all, will be fitted with elevators. The view from these points will be a striking one, the environs of Stockholm being of unusual beauty. At each side of the central structure will be a pavilion. To the left of the entrance is the building for the various offices, and those of Norway, Sweden, and Denmark are located there. To the right lies the Northern Museum, which is still in course of erection, and where in an auxiliary building the sections for hygiene, education, and engineering will be installed. The machinery hall will be situated at the Saltsjön and will be built of iron and glass alone, with an area of about 100,000 square feet. The fisheries exhibition will be located on the borders of the sea, and there will also be found the exhibition of boats, etc. Fishery forms one of the more important industries in Sweden, and this section is to be made large and interesting. The section for forestry will also be comprehensive, as will the agricultural section, the agricultural department being much interested in the matter. The art exhibition will in all probability be entirely international. There will be three large halls for Sweden, Norway, and Denmark, and smaller buildings for other countries. The two large universities in Sweden—Lund and Upsala—will also be represented, as well as the medical college, Stockholm.—Journal of the Society of Arts.

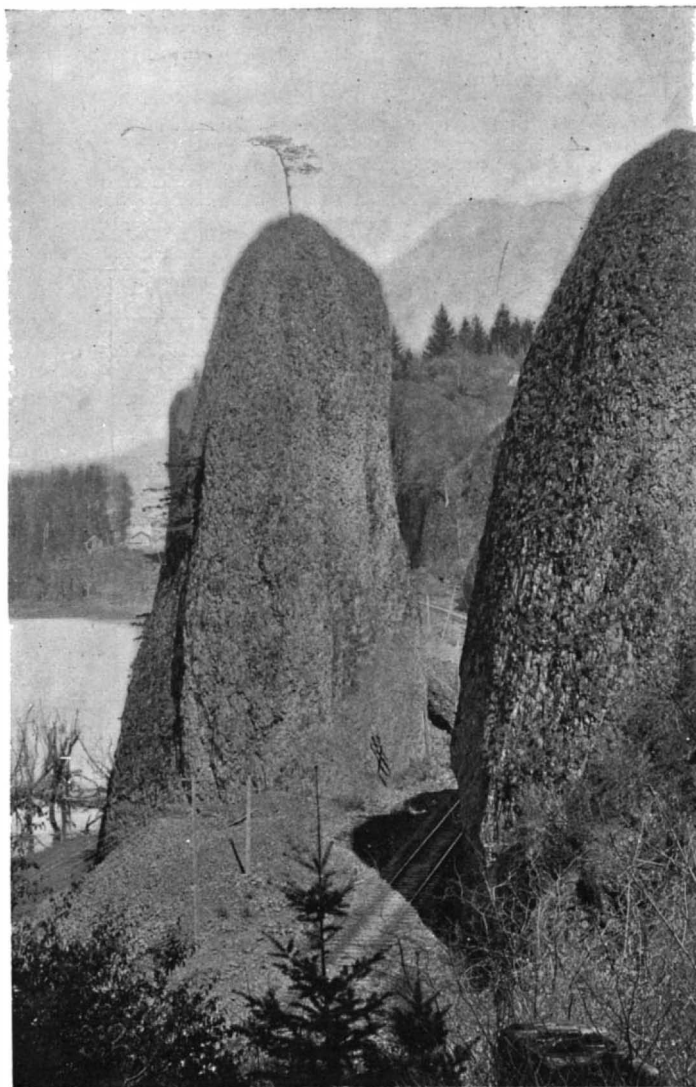

HERCULES PILLARS—DETACHED PILLARS OF ROCK ON THE BANKS OF THE COLUMBIA RIVER OREGON.

ceptions to the rule. The herbivora betrayed a greater liking for the salt than the carnivora, and in the same way agricultural populations, who were more or less vegetarians, were invariably large consumers of it. The tribes who ate no salt led a pastoral or nomadic existence, whose regimen was almost exclusively animal. This, said the writer, had led Bunge to formulate the theory that as vegetables contained principally potassium salts, these latter replaced the sodium salts in the economy, and the vegetarian instinctively craved for common salt in order to compensate for its loss

by four turrets, of which some, if not all, will be fitted with elevators. The view from these points will be a striking one, the environs of Stockholm being of unusual beauty. At each side of the central structure will be a pavilion. To the left of the entrance is the building for the various offices, and those of Norway, Sweden, and Denmark are located there. To the right lies the Northern Museum, which is still in course of erection, and where in an auxiliary building the sections for hygiene, education, and engineering will be installed.



MEMELUSE ISLAND—AN INDIAN BURIAL GROUND ON THE COLUMBIA RIVER, OREGON.

through the kidneys. This theory was, however, weak, for it did not explain why certain peoples who had not access to sea salt replaced it by salts of potassium obtained by the incineration of plants.

Such a people were the negro inhabitants (a million)

be established in Victoria Land. The station will be run in connection with the German South Polar Expedition, which will have for its object the determination of the meteorological conditions during the severe antarctic winter.

THE BERTILLON SYSTEM OF IDENTIFICATION BY MEASUREMENT.

It is estimated that there are about 1,500,000,000 people upon the face of the earth at the present time. If any one had been so bold as to affirm, only a few years ago, that it would be possible to give such a description of any one individual that he could be positively identified among all these millions, his statement would have been met with ridicule. To-day, however, thanks to the researches of Quetelet, the Belgian scientist, and the subsequent labors of Dr. Alphonse Bertillon, a celebrated French anthropologist, we are able to record such a detailed description of any given individual that his identification becomes a matter of absolute certainty.

Although it is true that the Bertillon System of Anthropometric Identification, as it is called, is primarily intended for the prevention of crime, this is only one of the objects of the system. In every case where the establishment of the identity of an individual is desirable, whether for his own benefit or that of his family, or the State, this ingenious and highly scientific system may be applied. The victims of the cable car or the railroad accident, the slain upon the battlefield, the unclaimed bodies at the city morgue, all present cases for which Bertillon has made full provision; and in instances where the body has been mutilated beyond all possibility of recognition by the usual methods of identification, the system would be simply invaluable. Further instances of its possible usefulness would have been the prevention of frauds on the United States Pension Bureau by parties who have assumed the name and condition of others, the detection of false claimants to estates, the prevention of the landing of Chinese who come to this country bearing the name and papers of others of their countrymen who have returned to China. It requires a long acquaintance with this race to be able to distinguish one celestial from another, and by the present methods of identification it is almost impossible for the government officials to detect a fraud of this kind.

Perhaps there is no sphere in which the benefits of the system would be more immediately felt than in the army, where it would act as a check upon desertion from the very day of its introduction. In time of war, moreover, it would serve as an infallible identification of the killed and wounded, and in subsequent years, as suggested above, it would prevent fraud upon the Pension Bureau of the country. The question of its introduction into the army is being actively urged by Dr. Paul R. Brown, United States Army, to whom we are indebted for valuable assistance in the preparation of the present article.

The Bertillon system for measuring criminals has received its most extensive trial in France, where it has been carried out for over ten years with the thoroughness for which the police of that country is famous. It is in general use also in Belgium, Switzerland, Russia and several South American republics, and is being tested in England. It was introduced into the United States by Major R. W. McClaghry in 1887, and is now in operation in Illinois, Michigan, Wisconsin and the State of Massachusetts. It was adopted by the police department of the city of New York on March 6, 1896, and in May of the same year its use was made obligatory in all the prisons and penitentiaries of the State of New York.

The accompanying illustrations show the practical operation of the Bertillon system at police headquarters in this city. It varies in no essential particulars from that of the countries and States above mentioned, only such slight modifications as were suggested by local conditions having been made in minor details. The system is made up of three distinct parts. First, the measurement of certain unchangeable "bony lengths" of the body; second, a careful description of the features of the face; third, a careful localization of all the scars and marks upon the body. Of these three the first records are by far the most important, because the most permanent and unalterable. Bertillon states that the experience of the last ten years has shown the "almost absolute immutability" of the human frame after the twentieth year is passed. The great diversity of dimension which the skeleton shows in different subjects, and the facility and precision with which it may be measured, render this means of identification by far the most reliable that could be adopted. Increasing age and mutilation will produce changes in the features, but they cannot affect the measurements of the frame. The analysis of the features of the face, and the description and localization of scars upon the body, add their accumulated testimony to the unchanging record of the measuring apparatus.

The bony or skeleton lengths adopted by the police department as admitting of easy measurement and description are as follows: The length and width of the head; the cheek width; the lengths of the foot, the middle finger, the little finger and the cubit, that is, from the elbow to the tip of middle finger; the height standing; the height seated; and the stretch; and in addition to these the right ear length, which, while not a skeleton measurement, remains virtually the same through life.

The apparatus which is used for taking these dimensions is very simple, as will be seen by reference to the illustrations. In taking the height the criminal is made to stand barefooted with his back to the wall and his

BUREAU OF IDENTIFICATION.—Police Department, City of New York.

NAME.....
 Aliases.....
 Residence.....
 Crime.....
 Officer.....
 Disposition of Case.....
 Previous Arrests.....

ORDER	MARKS, SCARS, MOLES, DEFORMITIES, ETC.
I	
II	
III	
IV	
V	
VI	

Peculiarities of Habit and Action.....
 Criminal History.....

BACK OF IDENTIFICATION CARD.

backbone to the left of the graduated vertical scale. The square is then brought down with its vertical edge in contact with the vertical edge of the scale and the height read off. About three feet to the left of the scale is a vertical strip which projects about an inch from the wall, and on the opposite side of the scale is a horizontal scale with long graduation lines, as shown in the illustration. The criminal, with his back still to the wall, is made to extend his arms and move to the right or left until the tip of the middle finger of the right hand touches the vertical strip. The measurer then presses the arms of the subject lightly against the wall and reads off the "stretch" as indicated by the middle finger tip of the left hand. The trunk measure-

over the back of the head. The thumbscrew is then tightened and the measurement checked by passing the instrument again over the head. The width of the head and over the cheeks is taken in the same way.

The measurement of the foot is taken with a caliper rule somewhat similar to that used by a shoemaker. The subject is placed on the stool, standing on his left foot and steadying himself as shown in the illustration. The graduated stem is placed against the inside of the foot with the fixed arm in contact with the heel, and the sliding arm is then brought in lightly against the toe. Care is taken as before to check the reading.

In measuring the left middle and little fingers, the back of the caliper rule is used, two small projections being provided on the fixed and sliding arms. The finger to be measured is bent at right angles to the back of the hand, and the measurement is taken from the tip of the finger to the knuckle, as shown.

The cubit measurement is taken from the elbow to the tip of the middle finger. The forearm and hand are placed, with the palm of the hand downward, upon the surface of a trestle on which is a caliper rule; the edge of the table, the axis of the forearm and hand, and the graduated stem of the rule all being parallel. The elbow is placed against the fixed arm of the rule, and the loose arm is then brought up to the middle finger and the measurement read off on the scale.

The measurement of the right ear is taken with a caliper rule, which has a flat fixed branch which is steadied by pressing it against the head and is brought down until it grazes the upper border of the ear. The stem is held parallel with the axis of the ear, and the loose arm is pushed up until it just touches the lobe of the ear.

It will be apparent to the reader from this description and the illustrations that this system will give a series of very accurate measurements. As each one is read off it is written down on a printed card, similar to the one which is shown on this page.

The measurements being all taken, the next analysis is that of the features of the face. As these are liable to change with age or disfigurement, no measurements are taken, but, instead, an elaborate and exhaustive description is given. Taking the nose as an example, the profile of the bridge may be rectilinear, convex or concave, and the term sinuous might be applied to qualify each of the above descriptions. Thus a nose might be convex sinuous, that is it might be generally convex and also somewhat undulating in contour. Then again each of these types might vary so far as its base was concerned, this being either elevated, horizontal or depressed. The subdivision might be carried still further by certain arbitrary marks as follows: [concave], concave, concave, where in brackets the word would mean slightly concave, without brackets or underlining it would mean moderately concave, and underlined, it would mean extremely concave. This system of seriation could be applied to any features of the face. The eyes will vary from the pale blue of the Scandinavian to the very dark brown of the negro. In the Bertillon system there are seven distinct classes of eyes enumerated, with nine subdivisions. The mouth, the chin, the brow, have all been analytically classified, divided and subdivided—even the complexion being noted in respect of its coloration, which may vary from the sanguineous coloration of the florid Englishman to the pigmentary coloration of a dark Italian, with all the intermediate gradations between the two extremes.

The third step in registering a criminal is to make an exact record of all scars, marks or deformities. To assist in locating these on the body, certain anatomical points, known as "guiding points," are employed, and the particular mark is described as being such a distance from one of these points.

Finally, the subject is placed before the camera, two negatives, a full face and profile, being taken, and the photographs are mounted in the center of the identification card.

We reproduce a fac-simile of the style of cards in use at the police department of the city of New York. In addition to the data recorded on the face of the card, there is provision on the reverse side for recording the particulars of the name, aliases, crime, date of sentence, peculiarities of habit, criminal history, etc., and there are six ruled spaces for inserting

details regarding the marks, scars, etc., upon the body. After each card has been made out in duplicate and filed, the examination is complete, and the department is in possession of a means of future identification which may be said to be absolutely infallible.

The method of filing the cards adopted at the identification bureau in Paris, over which Dr. Bertillon still presides, is as follows: The cards are filed in two large cases, in one of which they are classified alphabetically,

(S) (M) (L)

Height 1 m.....	Head lgh.....	L Foot.....	Class.....	Age.....	Born in.....
Stretch 1 m.....	Head width.....	L Mid F.....	Color L Eye.....	Areola.....	Apparent Age.....
Trunk.....	Cheek width.....	L Lit F.....	Periph.....	Periph.....	Nativity.....
Curv.....	R Ear lgh.....	L Cubit.....	Pecul.....	Pecul.....	Occupation.....

Remarks relative to Measurements.....

(P)

(E)

(D)

(C)

(U)

(B)

(H)

(G)

(T)





(1)

(2)

(3)

(4)

(5)

(6)

(7)

(8)

(9)

Forehead	Inc.....	Profile	Bridge.....	R Ear	Border.....	Hair.....	Beard.....
	Hght.....		Base.....		Lobe.....		Complexion.....
Nose	Width.....	Teeth.....	DIMENSIONS		Ch.....	Weight.....	Build.....
	Pecul.....		Height.....	Projection.....			
			Pecul.....				

POLICE DEPARTMENT, CITY OF NEW YORK, BUREAU OF IDENTIFICATION.

IDENTIFICATION CARD.

Examined..... at..... 189.....
 By.....
 Re-examined..... at..... 189.....
 By.....

ment, or the height of a man when seated, is taken by placing a stool against the wall, seating the criminal squarely upon it with his back to the wall, and taking the height as before with the portable square.

The measurements of the head are taken while the subject is still seated and are read off on a pair of calipers provided with a graduated arc. In taking the length the left point of the calipers is held at the root of the nose, and the right point is brought down

and in the other according to measurements or anthropometrically. The latter case is divided horizontally into three equal compartments for lengths of head, and into three vertical divisions for breadths of head, and there are other subdivisions for the three classes of finger, foot, and cubit lengths. The cards are filed in boxes numbered I to V according to the above leading measurements. If the police desire to know whether a criminal has been previously measured, he is identified or otherwise by looking in the alphabetical collection; that is if he gives his right name. If the prisoner claims that he has never been arrested before, he is measured and search is made in the measurement collection. The head is say 187 millimeters. The medium head measures from 185 to 190 millimeters; so the card is put in the medium class. This eliminates 100,000 cards from the 150,000 in the collection. The breadth of head being below medium, two-thirds of the 50,000 are eliminated, leaving 16,666. The middle finger eliminates some thousands more, bringing the remainder down to 5,555. The length of the foot reduces the number to 1,850, and the cubit length brings it to 620. Following out the process in respect of the height, little finger, ear, trunk and stretch, the remainder is represented by a dozen cards which are classified according to the color of the eye. The card is now located, and the photographs and facial description place the identity of the two cards beyond the possibility of a doubt. Our sketches were made at the Identification Bureau of the New York Police Department through the courtesy of Commissioner Andrews.

Luminous Photographs.

These photographs, according to J. A. Randall in an article on "The Magic and Mystery of Photography," published in the American Journal of Photography, January, were first introduced at a ball in Vienna, where programmes were decorated with a luminous picture representing an alchemist at work. "There are several ways of making luminous photographs, the simplest being that of W. B. Woodbury. A sheet of cardboard is coated with a luminous paint and exposed to light under a glass positive or transparency. On removing the cardboard to a dark room a striking and brilliant phosphorescent image is seen, with all the gradations of the positive. The effect may also be produced by arranging a series of glass tubes, containing a phosphorescent substance, behind a thin glass positive; on exposure to light the luminosity of the tubes will shine through the positive in proportion to its density. When viewed in the dark, a glowing image is the result. Another method, which can be applied to an ordinary print on thin paper, is as follows: Take a sheet of cardboard, and spread over it as evenly as possible a thin coating of starch paste; when still tacky dust over it an even layer of powdered calcium or barium sulphide, rubbing it well over with a brush to make it adhere in every part. Then take the print, which should be light, and fixed and toned as usual, and saturate it with a mixture of castor oil and oil of turpentine, taking off all excess with a clean rag. The print, thus made semi-transparent, is next pasted upon the prepared cardboard, and the whole well dried before the fire. A print thus prepared, when exposed to light, receives the rays on the phosphorescent sulphide beneath, which becomes luminous in proportion to the absorption which has taken place; it is therefore luminous in the dark by the light transmitted. A silver print is soon destroyed by this process, for the sulphide attacks the image; it can be applied to the carbon or other processes not having silver as a basis. Moonlight pictures and landscapes give the most striking effects as luminous photographs."

Some Water Uses Well to Remember.

The Phrenological Journal gives the following useful hints on the applications of water in severe attacks of illness. The adult members of a family should keep them in mind for an emergency.

A strip of flannel or a soft napkin, folded lengthwise and dipped in hot water and wrung out, and then applied around the neck of a child that has the croup, will usually bring relief in a few minutes.

A proper towel folded several times, and dipped in hot water, quickly wrung and applied over the site of toothache or neuralgia, will generally afford prompt relief.

This treatment for colic has been found to work like magic.

Nothing so promptly cuts short a congestion of the lungs, sore throat, or rheumatism as hot water, when applied early in the case and thoroughly.

Hot water taken freely half an hour before bedtime is an excellent cathartic in the case of constipation, while it has a soothing effect upon the stomach and bowels.

This treatment, continued a few months, with the addition of a cup of hot water slowly sipped half an hour before each meal, with proper attention to diet, will cure most cases of dyspepsia.

Ordinary headaches almost always yield to the simultaneous application of hot water to the feet and back of the neck.

Science Notes.

The roller steamer Ernest Bazin has been finished at Rouen and will shortly have a sea trial.

P. Regnard and T. Schloesing have examined the gases obtained from a liter of blood, and found that they contained 20.4 c. c. of nitrogen and argon, the latter gas accounting for 0.419 c. c. of the mixture. In addition to satisfying themselves that argon is dissolved in the blood, they state that if there is an increase in the amount of nitrogen present, there will also be an increase in the amount of argon.—Comptes Rendus, cxxiv, 302.

The Swiss government has sanctioned the manufacture and use of weights made of glass. They are of slightly conical shape with rounded bottom edge, and provided on top with a knob to facilitate handling. The designation is moulded into the knob. The glass used for these weights is of special composition, highly refined, and carefully annealed so as to reduce to a minimum the danger of breakage.

We regret to record the death of Mr. Harry Proctor, youngest son of the late R. A. Proctor, whose name was for many years so closely associated with the English scientific journal Knowledge. He died on December 20 last, after having recently attained his majority. The young man, like his father before him, betrayed a predilection for things scientific; but, unfortunately, constitutional weakness thwarted all serious efforts in this direction.

The largest spectroscope in the world has just been completed by Mr. John A. Brashear, of Allegheny, Pa., the well known astronomical instrument maker. It was made for the private research laboratory of Dr. Hans Hauswaldt, a wealthy scientist of Magdeburg, Germany. The instrument contains a concave diffraction grating with 110,000 lines per inch, made on the famous ruling machine of Prof. Henry A. Rowland, of the Johns Hopkins University.

"It has been found by M. J. Puluji," says the Electrical World, "that substances which fluoresce most brightly under the visible cathode rays give off the greatest amount of Roentgen radiation. M. Puluji believes that Roentgen ether waves originate in the bombardment by negatively charged molecules from the cathode and in the abrupt loss of charge in these. He finds that these Roentgen ether waves may cause fluorescence of calcium sulphide, but believes that invisible as well as visible radiations emanate from a screen of this substance. M. Puluji states that vacuum tubes of all kinds glow when subjected to the action of Roentgen rays.

M. B. Renault has long worked at the indications of bacteria found in geological strata, and now publishes the general result of his observations in a paper illustrated with a large number of drawings. As might be expected from their simple structure, bacteria appear to have been coeval with the first appearance of organic life on the earth, the coccoid form being apparently earlier than the bacillar. Indications of their presence are found in bone, teeth, scales, and coprolites, as well as abundantly in vegetable tissues, the spores and sporanges of ferns appearing to have been especially subject to their attacks. The species are, as a rule, distinct from those at present in existence.—Ann. des Sciences Naturelles (Botanique), 1896.

Professor Meidinger, of Carlsruhe, finds wonderfully little difference between the heat radiating power of a Bunsen flame and that of an illuminating gas flame, per unit of area, that is. In this he confirms the conclusions reached in 1865 by Prof. Magnus, who also found that making a Bunsen flame luminous by means of salt, etc., did not increase its radiative power. The inference would be that there is next to no actually solid substance in a luminous flame, or else that the higher temperature of a Bunsen flame (1,750° C. as against 1,300° C.) makes up for its deficiency in solid particles. A gas blowpipe flame, on the other hand, rapidly falls off in heat radiating power as the air is more and more forcibly driven through it. From an ordinary Bunsen flame, says the Progressive Age, about one-seventh of the heat passes away by direct radiation.

Prof. F. Plateau, of the University of Ghent, has for many years carried on a series of observations on the mode in which insects are attracted to flowers, the results of which are published in the Bulletin of the Royal Academy of Sciences of Belgium. His conclusions are not in accord with those of Darwin, that the bright color of the corolla acts as a beacon to attract insects. He believes that they are attracted chiefly by some other sense than that of sight, probably that of smell. In the case of the dahlia (single) and other species of Compositæ, the removal of the conspicuous ray florets had but little effect on the visits of insects; nor had the removal of the conspicuous part of the corolla in other flowers, as long as the nectary remained. On the other hand, says Nature, the artificial placing of honey on otherwise scentless flowers resulted in their being immediately visited by numbers of insects. Where the same species varies in the color of the flower, as between blue and white, or red and white, insects visit quite indifferently flowers of different colors belonging to the same species.

Archæological News.

An excellent guide to the archæological treasures of Rome has recently been published by a well known German archæologist, Herr Helbig. It is a most useful work for any one who wishes to make a study of the art treasures of the Eternal City.

In a paper read before a late meeting of the Paris Academy of Sciences, by M. Berthelot, on "The Age of Copper in Chaldea," the author said the analysis of a spear carrying drawings and inscriptions, and at least 4,000 years old, showed that the metal was nearly pure copper, neither tin, lead, arsenic, nor antimony being present in appreciable quantities. The oxidized portion was nearly pure atacamite, $3\text{CuO} \cdot \text{CuCl}_2 + 4\text{H}_2\text{O}$. The description of these and similar objects as bronze is shown to be erroneous. Copper appears to have preceded bronze in the manufacture of tools.

The plans for the restoration of Malmaison, which were prepared with the aid of M. Daumet, are now complete, says the Architect. The estimated cost of the works is 480,000 francs, and does not comprise the outlay on the decoration of the interior or on the gardens. M. Osiris, who has enriched France with so many costly memorials, intends to have the restoration scheme carried out in its integrity. Malmaison will recall associations of Bonaparte and Josephine for many a year to come. The charge of the building will be undertaken by the Department of Fine Arts. The coming international exhibition has incited M. Osiris to further generosity. In 1889 he offered 100,000 francs to reward the author of the work which was considered to be most interesting as an example of art, industry or public utility. A similar sum will be available for the exhibition for 1900, and, as in the former case, the selection will be left to the syndicate of the press.

Under the will of the late Lady Wallace, the whole of the collections at Hertford House, Manchester Square, London, so far as they are contained on the ground floor, the first floor, and the galleries, have been bequeathed to the British nation, on condition that the government shall provide a site in some central part of London and build a museum to contain the collections, which are to be kept together and styled the "Wallace Collection." The collection is probably the finest private one in the world, and its money value is roughly estimated at considerably over \$5,000,000, and some experts have even estimated the value as high as \$17,000,000. The Borghese, the Lichtenstein, the Ellesmere, and perhaps one or two of the collections of the Rothschild family may equal or surpass it in pictures alone; three or four houses in Europe may have as much old furniture of the highest class; possibly in Germany or Austria some one might be found with as good armor. But it is the combination of all these things, and of many other departments, that makes the Wallace collection unapproachable.

The fiftieth anniversary of the founding of the French school at Athens, Greece, is to be commemorated by an archæological congress to be held in Athens from April 26 to 28 of the present year, says Architecture and Building. The announcement is made by a committee composed of the rector of the University of Athens, the general ephor of antiquities at Athens, and the heads of the various archæological schools under the presidency of M. Homolle, director of the French School. It is proposed that this congress, in case the experiment proves a success, shall be the first of a continuous series of such congresses, to be held at such places and times as the congress itself may determine. In case this congress is made a permanent institution, it may meet in future years at different cities of Europe and America. The subjects proposed for discussion in the congress are such as have a general interest and bearing. The discussion of purely scientific problems is not proposed so much as the consideration of practical questions of method in the organization of work and questions of educational interest.

We have several times, says Nature, called attention to Dr. G. Folgheraiter's interesting observations on the magnetization of Etruscan vases. Hitherto there has been a slight uncertainty as to whether the magnetization may not have undergone some modification during the many centuries that have elapsed since these vases were baked. In his latest contribution to the *Atti dei Lincei*, Dr. Folgheraiter dispels any doubts on the matter by his observations on some vases which were pieced together from scattered fragments discovered in excavations at Arezzo. If the magnetization of the terra-cotta had in any way altered since they were broken, it is clear that the different portions would have been differently affected, and the mended vases would have shown somewhat irregular magnetization. So far from this being the case, they were found to be as regularly magnetized as those which had been excavated entire, the opposite poles at the mouth and base being exactly 180 degrees apart. The only remaining element of uncertainty is what was the orientation of the vases in the kiln; and Dr. Folgheraiter hopes that further excavations may lead to the discovery of potteries of the Etruscan epoch containing vases in situ. Should he be successful, we may look forward to exact determinations of the magnetic elements, which will greatly add to our knowledge of terrestrial magnetism.

A NEW FAST JOB PRINTING PRESS.

Printers everywhere cannot fail to be interested in the fast automatic feed card and envelope press shown in the accompanying illustration, which has been recently patented in the United States and several foreign countries, and is being manufactured by the Harris Automatic Press Company, of Niles, Ohio. In all considerable job printing offices a number of presses are usually kept employed on small work, such as the printing of cards and envelopes, etc., about a thousand impressions per hour being the ordinary rate of speed, and each press requiring the close attention of a feeder. The Harris press is self-feeding, the cards and envelopes being supplied to it by the pack, and it works easily at speeds ranging from 8,000 to 10,000 impressions per hour. Working at this rate, it is about as much as one hand can do to open envelope boxes or packages of cards for feeding, and replace in the boxes or packages the printed work, but the feeding, printing and delivery are automatically performed. The press is designed to do all classes of work, from the finest half tone on glazed cards to the thinnest manila envelopes, taking sizes from the smallest envelope corner to an 11 x 13 inch plate. It prints from curved electro or stereotype plates, readily adjusted to exact position on the impression cylinder by clamps, and adapted to be "underlaid" with good results, as the plates are only three-sixteenths of an inch thick, the "making ready" of all kinds of jobs being thus greatly facilitated.

The points which will first attract the attention of the practical printer are the nicety and exactness of the feed and the connected parts. The cards or envelopes are placed in a pile within the space formed by the vertical rods or posts in front of the impression cylinder, these guards and supports being quickly adjustable for all sizes of stock, and the bottom card or envelope is automatically pushed forward by the feeding mechanism to the printing cylinders. For envelopes the flap is engaged by fingers, by which the envelope is fed forward through a gate, so nicely adjusted, according to the thickness of the paper, as to prevent the passage of more than one envelope at a time. In printing cards, the bottom card of the pile is pushed forward by fingers which extend beneath the card, but which have on their upper face an adjustable flange or lip, to be raised just sufficiently to nearly equal the thickness of the card. In the adjustment of this lip or flange, as in that of the gage to prevent more than one card or envelope to be passed at a time to the printing cylinders, the devices are very simple, and admit of almost instantaneous adjustment for any special thickness of cards or paper. The feeders are carried on a light reciprocating frame, and, should an envelope or card fail to be fed forward, an automatic throw-off device lowers the impression cylinder and a friction clutch or brake stops the press, thus preventing the smearing of the tympan sheet and the spoiling and wasting of stock. The press gives perfect register, the stock being "overfed" against adjustable gage stops on the impression cylinder and held there by two short tapes until pressed under the types, and the adjustment of the impression is easily and accurately made when the machine is running at full speed. The printed stock is delivered on a circular tray at the back, the tray being slowly revolved and thus laying out the printed matter in such a way as to prevent offset. The ink distribution and roller adjustment and interchangeability apparently leave nothing to be desired. The company furnish with the machine, when desired, a small plate making outfit. The press occupies a floor space of 3 feet 6 inches by 5 feet, and weighs 1,100 pounds.

THE GLACIERS OF GREENLAND.

BY PROF. RALPH S. TARR.

That great triangular area of land between northern Europe and America, by some strange reason called Greenland, is almost entirely covered by snow and ice. Its margin is that of an extremely irregular land quite like northern Europe and America, with many penin-

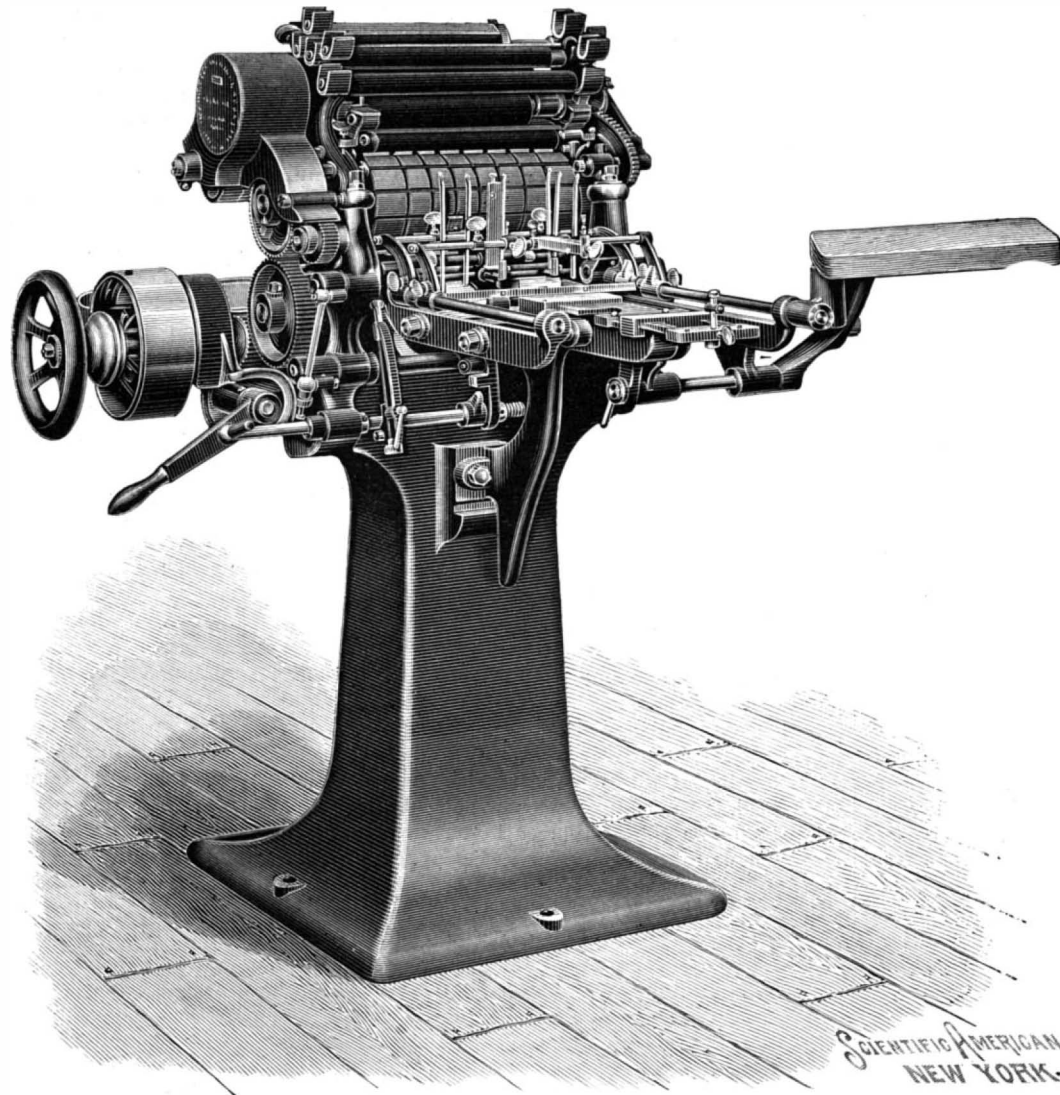

THE HARRIS AUTOMATIC CARD AND ENVELOPE PRESS.

sulas projecting, and many fjords, bays and straits indenting the coast. The projecting parts of the land, the peninsulas and islands, are mainly free from glaciers, though even upon these, in the protected valleys and on the higher peaks and plateaus, there are glaciers of great or small size. However, taken as a whole, the margin of Greenland is free from ice. All the interior is ice covered and the total area of the ice is estimated to be about five hundred thousand square miles. In some parts of the interior this great ice cap attains an elevation of not far from ten thousand feet.

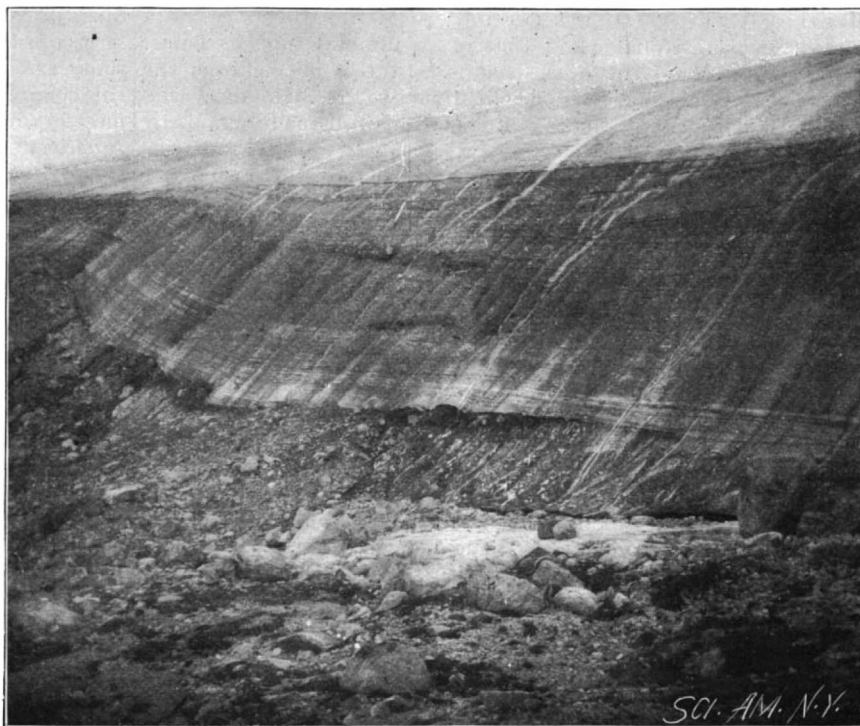

Fig. 1.—LAND MARGIN OF CORNELL GLACIER.

After passing the land margin of Greenland one comes to an ice wall, sometimes very precipitous, but more often sloping so that it can be ascended. This wall rises one or two hundred feet above the base, and then the ascent becomes more gradual. Here the surface of the ice is generally smooth and easily traversed, though if by chance the ascent is made on a part of

the glacier that is rapidly moving, the surface is so rough that traveling across it is impossible. Within a few miles of the margin, the elevation of the ice is one or two thousand feet above the sea level, and looking onward toward the interior of Greenland, there is a great plateau or mountainous expanse of snow and ice. It looks like a plain, but as one traverses it the barometer

shows that the elevation is constantly increasing. Near the margin, where the elevation is slight, the summer sun has melted the surface, so that it is solid and hard and firm under foot. Its surface is pitted by circular depressions caused by melting, and the walls of these wells are seen to be made of pure ice. If the journey chanced to be made during the autumn, it is possible that the form of precipitation may be that of snow; but it is very much more likely to be in the form of rain. However, as the high interior is approached, the climate becomes colder and colder, and even in summer rain does not fall, nor does the surface of the ice cap melt and show the solid ice of the glacier. It is then a snow-covered glacier, sometimes with hard surface, at other times enveloped in soft and drifted snow. According to the description of Peary, the summer climate in the interior of Greenland is one of the most disagreeable of any that have so far been found in the world.

This constant fall of snow, with almost no loss by melting, has completely buried the interior of Greenland. Whatever the land condition beneath the ice may be, it is so effectually buried that even the great irregularities appear to produce no effect upon the surface of the ice cap. Judging by the margin of Greenland, this interior must be a highland of mountains and irregular topography, but it is entirely smoothed over by the ice. The fall of snow in summer and winter has not only obscured the topography of the land, but has raised the level of Greenland far above the normal. It is impossible to say how much this snow fall amounts to in the course of a year, but it can hardly be less than ten feet. Practically none of this melts and but a portion of it is blown away to regions where melting can occur. Hence, if no means of escape could be found, the elevation would continue to increase practically indefinitely. A thousand years at this rate would increase the elevation ten thousand feet.

It happens that the ice find means of escape other than that of wind action and melting. As the snow accumulates, the pressure of the crystals against one another, under the burden of the snow above, causes an increased compactness, and eventually a change from the loose condition of snow to that of solid ice, as one may change a snowball to ice by pressure. There is a question in the minds of some whether ice is a viscous body or not, and hence it may be well not to speak of it here as a viscous substance. In any event, it cannot be denied that ice moves and behaves like a viscous body. If we should pile a mass of wax upon a table and subject it to pressure, it would spread outward from the center of pressure in all directions, because the wax is a viscous body. The same is true of ice, which, although apparently brittle, will flow when subjected to a strong but slowly applied pressure. The weight of the accumulation of snow in the interior of Greenland squeezes this ice that has been formed and causes it to move outward from the center of greatest elevation.

It is possible also that this movement is aided somewhat by gravity, for it may be that the land base in the interior of Greenland is higher than the land margin, and that there is, therefore, a gradual slope from inland to the sea.

No means of determining the rate of this ice movement are at hand. The studies of the Greenland ice

sheet have been entirely too limited in number to allow even a guess upon this point. Some of the tongues from the ice have had their movement measured, but the great ice cap itself has never been studied from this standpoint. One has but to look at the glaciers of Greenland to see that the rate of motion of the ice cap is exceedingly slight, probably to be measured by only a few inches a year.

If the movement were more rapid than this, the surface would be broken by cracks caused by the strains on the ice as it moved over its bed. Cracks or crevasses are confined to small portions of the glacier where the ice is moving down the valley toward the sea, and hence moving rapidly.

The surface of the glacier is absolutely free from all foreign materials, with the exception of moraines, which extend seaward from the few mountain peaks that rise above the surface of the ice near the margin. Beyond the limit of mountainous islands in the ice, or nunataks, even this supply of debris is absent. The second exception is found in a small amount of dust transported to the ice surface from the land by the action of the wind.

This dust is made of extremely fine particles of clay, and over the ice surface near the margin there is a considerable quantity of it. It represents the accumulation of years, and is not in sufficient quantity to darken the surface of the glacier. Indeed, it generally remains below the surface at a depth of a few inches or a foot; for, being dark in color, it absorbs the solar heat and bores its way into the ice by warming and melting it. Making a beginning of this sort in one place, the dust from other neighboring areas is washed toward the depression, and so a considerable quantity—perhaps as much as a quarter of a pound of dust—is found in a depression whose diameter is six or eight inches. The hole is bored into the ice only so far as the sun's rays can reach directly, which, of course, is not very far in this latitude, where the sun does not rise high in the heavens. These dust-filled depressions are known as dust wells, and they render the surface of the glacier near the land margin exceedingly irregular. In the winter they are frozen over and buried beneath the snowfall. The next summer they are perhaps reached again by the melting and added to by the accumulation of that year. In the meantime they are moving onward toward the margin and finally disappear into the sea with the ice itself. There is a zone extending from the land outward for a distance of a few miles where these dust wells occur. Beyond this zone, partly because the dust does not reach so far and partly because the melting action of the sun is not powerful enough to cause the wells, these phenomena are not observed.

Moving onward toward the sea in all directions, the ice near its margin encounters different conditions in different places. The movement of the ice in the glacier is in some respects not unlike that of a river. It resembles the river in this respect that it will seek and follow the lowest ground; but it differs in doing this less rapidly and successfully. Coming to the land margin, the glacier finds the topography to be irregular. There are hills, and ranges of hills, with intermediate valleys; and while, within the margin of the ice, all the land excepting the highest peaks is covered, the ice movement at the margin is mainly down the valleys. Therefore, since the valleys terminate in the sea, there are two important conditions along the ice margin, the contact of the greater part of the ice with the land itself, and the entrance of a few small portions or valley glacier tongues into the

sea. The ice from the interior advances toward the sea and then, as it comes to this margin, changes its course somewhat in accordance with the topography. It slopes down into the valleys and in some cases has its course changed nearly at right angles to the general direction of the movement of the ice cap itself.

If one should travel across Greenland near the coast,

As has been said, the edge of the glacier near the land has a slope of considerable steepness, and in some cases a precipice of ice from fifty to one hundred feet in height. The ice rests directly on the ground and is evidently in motion. The evidences of movement are in the first place the banding of the ice, a banding due to layers of gravel and pebbles whose sources must be

at some place other than their present position, for oftentimes there are pebbles of rock different in kind from that over which the ice is moving. The second evidence of motion is found in the more or less continuous series of low hills and ridges of gravel and boulders which have been brought by the ice and piled at its foot. There must be a supply for this material, much of which is foreign to the region, and this supply is of course the ice. In order to bring them, it must of necessity have moved. As it comes to the margin, where it is ending, it is prevented from proceeding further, partly because its movement is then diagonal to the general motion of the ice sheet, and hence down into the valleys, and partly because the melting by the summer sun pre-

vents its further progress. Evidence of this melting is partly the piles of accumulated materials at the base of the ice sheet and partly the drainage along the margin. This marginal drainage of the ice is exceedingly interesting. The water is furnished chiefly by the melting of the ice, and it comes not merely from melting on the front, but also from the surface. Every few feet along this margin there are tiny cascades and rills, and in some cases even rivulets, flowing rapidly down the front, and joining the stream that skirts the margin of the ice between the glacier and the land. Sometimes the water which flows along the margin is deflected from the immediate contact of the ice, and is forced to pass down some steep and rocky slope, forming then a beautiful cascade or waterfall. At other times it escapes beneath the ice, through a tunnel, reappearing again at distances varying from a few feet to several hundred yards. Again the accumulation of a moraine, or a barrier caused by ice, prevents the water from passing along as a stream and transforms it locally to a lake. These marginal lakes, some of which cover an area of a square mile, are exceedingly abundant, and in them the streams are depositing clay beds.

Along this land margin one can sometimes penetrate beneath the glacier in one of the ice caves which the marginal streams have cut in the glacier. Here he can see the ice, with a load of rock for tools, engaged in carving its bed. The boulders and gravel in the bottom layers are firmly frozen in the ice, and, as they are dragged along, they are grinding upon the rock, for they are the tools with which the glacier does its work of erosion. Along these bottom layers the ice is discolored for variable distances, sometimes to the height of one hundred feet above the base. This discoloration is due to rock fragments that the ice is carrying, and at first glance one gets an erroneous impression concerning the amount of this material that is being carried. Where streams have cut valleys in the ice front, as they course down its margin, it is seen that the discoloration of the ice surface is due to the action of melting, which has washed down over the surface a sheet of rock fragments which have been derived from only a relatively few layers. Above its bed the ice is carrying only a small amount of debris, and this decreases as we ascend, until, finally, the upper part of the glacier is pure, clear, white ice. Where it is present in

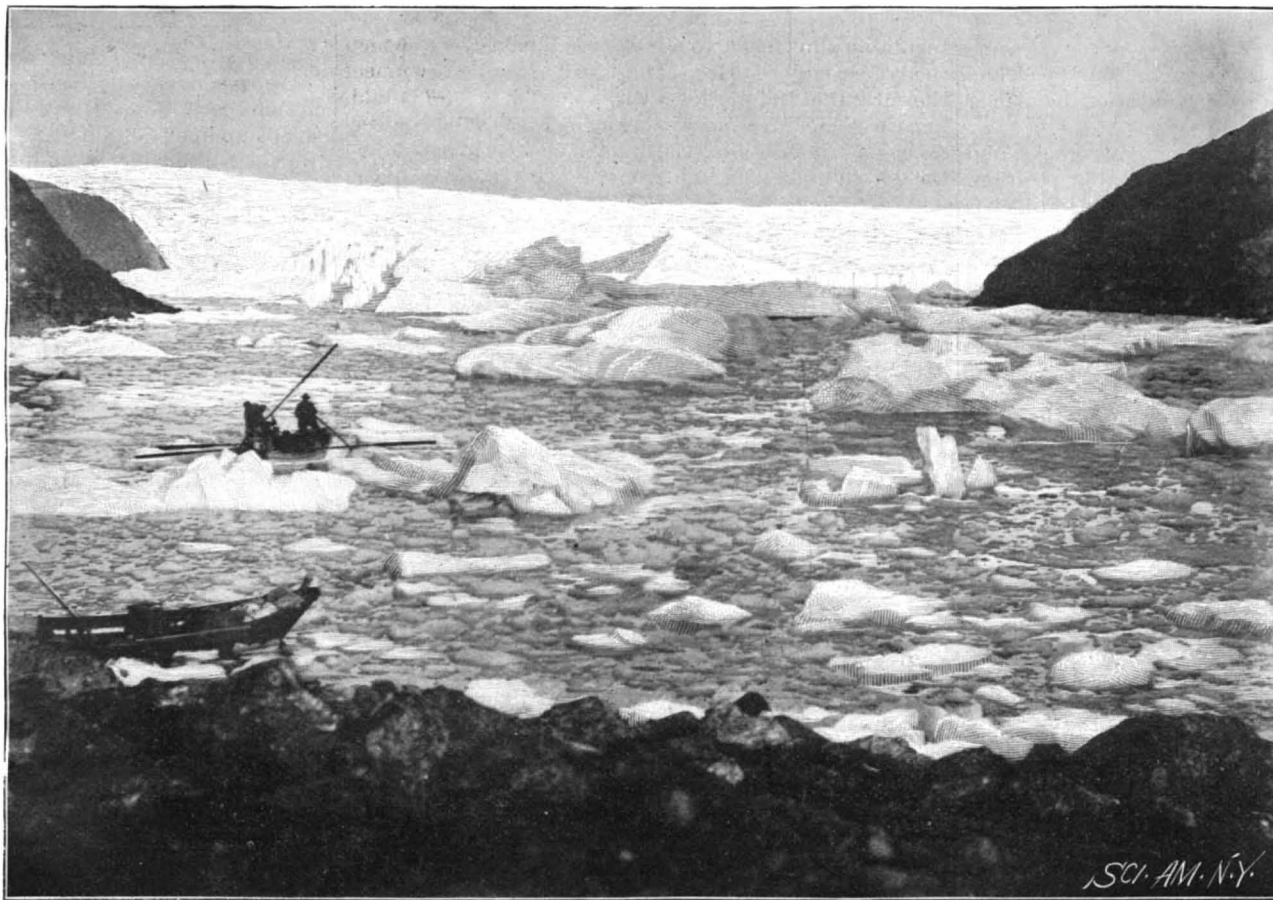

Fig. 2.—NORTHERN END OF GLACIER, SHOWING ICEBERGS AND FRAGMENTS OF GLACIER ICE FLOATING IN THE FJORD.

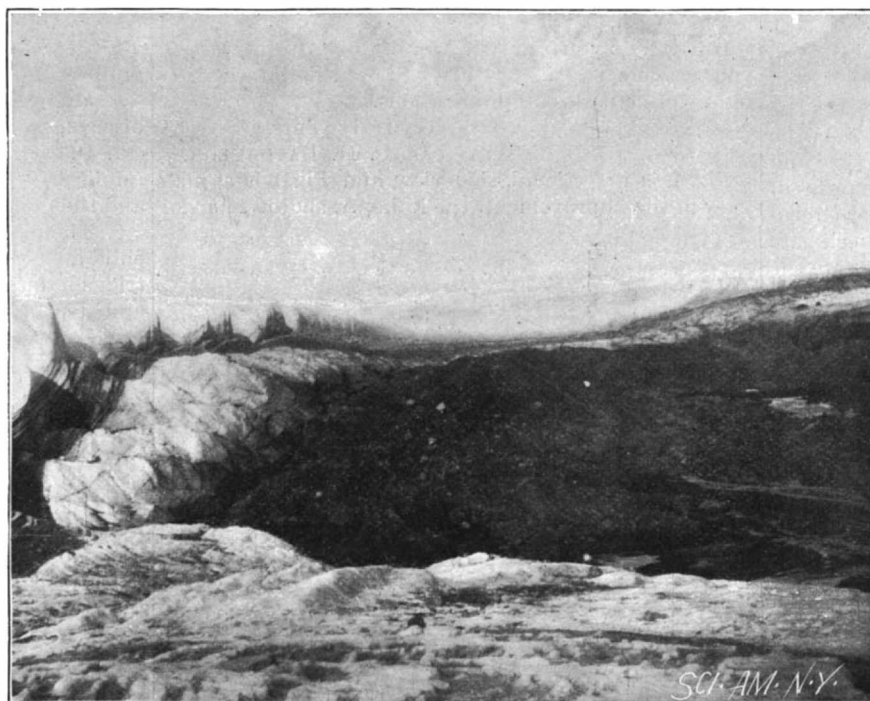

Fig. 3.—DISTANT VIEW OF LAND MARGIN OF CORNELL GLACIER.

rough is the surface by reason of these crevasses, and the effects of melting, that it is practically impossible to cross the surface. The rate of glacier movement, which during the summer season varies from a few feet to nearly one hundred feet a day, is so rapid that the ice cannot bend when it passes over the irregularities, but must break.

the bottom of the glacier, it is stratified with layers of clear ice.

Another kind of glacier front in this region is the sea wall of the valley tongue which is in rapid movement. This in places rises one or two hundred feet above the water, and extends to depths several times as great beneath it. As seen from the fjord it is a wall of marble whiteness, absolutely free from all impurities. Whatever rock debris the ice is carrying into the sea it is transporting below the water level. The top of this ice front is extremely irregular, partly by the cracking along the crevasses and partly by the action of melting. It is so irregular that travel over the end of the glacier is an impossibility.

In the front of the ice one sees numerous cracks, and the whole mass has an extremely unstable position. That this cracking does really represent instability is every now and then plainly proved, by the reports that proceed from the ice front, and by the fragments which one may see drop from its top and sides. Along the front of a large glacier there is a constant shower of these ice fragments, and the sea near by is littered with the bits of the glacier that have thus fallen into the sea.

Not only are fragments thus broken off by the melting and cracking above the water, but the ice is made unstable by the action of the waves at the shore line. When the tide is low one may see extensive undercut cliffs and sea caves of ice, which add distinctly to the instability of the ice cliff. This loss from the glacier front partly balances the advance, but not entirely. As one watches the front of one of the Greenland glaciers, every once in a while he sees a great block, hundreds of yards in length, crack off from the ice front and float away. Sometimes this ice breaks off from the glacier without producing much commotion, but much more frequently the masses of ice fall forward as they break off, and stir up the water, producing waves whose effects are felt miles away. The reason for the breaking off of these large bergs is the advance of the glacier into the fjord so far that the buoyancy of the water lifts and cracks it.

Hence the glacier which covers so large an area of Greenland advances outward until it is either destroyed by melting along the land margin or until it reaches some place in the sea where it breaks off and floats away. So long as the supply and these causes for the destruction of the glacier exactly counterbalance one another, the front of the glacier will remain permanently in one position; but if the supply exceeds, then the front of the glacier must advance upon the land and extend farther out into the sea; but, on the other hand, if the causes of destruction exceed the supply, the front of the ice must withdraw. This withdrawal may be accounted for either by a decrease in the supply of snow or a change in the climate, which causes an increased melting.

Studies along the margin of Greenland show that land now bare has within very recent geological times been encompassed by ice. In that part of Greenland near latitude 74°, where my studies were carried on, I found proof that the glacier has reached at least thirty miles further, covering all the land, some of which reaches nearly three thousand feet above the sea level. This means a very much greater extent of ice than the present. Even now the glacier is in process of retreat, and moraines that were evidently built at the base of the ice are now at some distance from it. Some of these moraines have been left by the ice so recently that no vegetation whatever, not even lichens, has found time to develop on the rock. Therefore, even at present the Greenland glacier is engaged in a withdrawal from the land, and this has been in progress for some time and has succeeded in uncovering a part of the margin of Greenland. How far this will go, and whether Greenland may again become the seat of a temperate climate and the site of a temperate flora, as it was before the glacial period, no one can even estimate.

Cornell University.

A FIRE ESCAPE AND WATER TOWER.

The illustration represents an improved fire department apparatus by which a platform may be readily raised and lowered to make connection with windows, enabling the firemen to enter the upper stories of a building for rescuing persons and facilitating the throwing of streams of water where desired in a burning structure. The improvement has been patented by Michael W. Hennessey, of No. 203 Sands Street, Brooklyn, N. Y., the inventor being chief machinist on the United States cruiser Columbia. On the truck is a platform frame, and means are provided for readily swinging the platform into level position when the truck stands on uneven ground. On the platform are two pairs of connected lazy tongs, the lower members of which on one side are pivotally connected with a stationary bracket, while the other lowermost members are pivotally connected with a cross piece sliding in bearings and formed with screw nuts in which screws a longitudinal screw rod. The outer end of this rod carries a hand wheel, by turning which the cross piece is moved forward or backward by the screw rod, closing or opening the lazy tongs. The uppermost members of

the lazy tongs on one side are pivoted to a platform to be raised, and the corresponding members on the other side carry rollers which loosely engage the under surface of the platform, the latter having posts and chains forming a railing on its sides and ends. On the platform is a turntable which may be turned to and locked in any position by removing and inserting a pin. On an extended portion of the turntable is pivoted a ladder, connected near its outer end to a yoke from which a rope passes over a pulley at the top of a post on the turntable and thence to a windlass, by means of which the ladder may be placed at any desired angle to connect the turntable and platform with the window of a building, the ladder preferably being made with extension sections, and its position as extended being indicated by the dotted lines. On the front of the truck platform

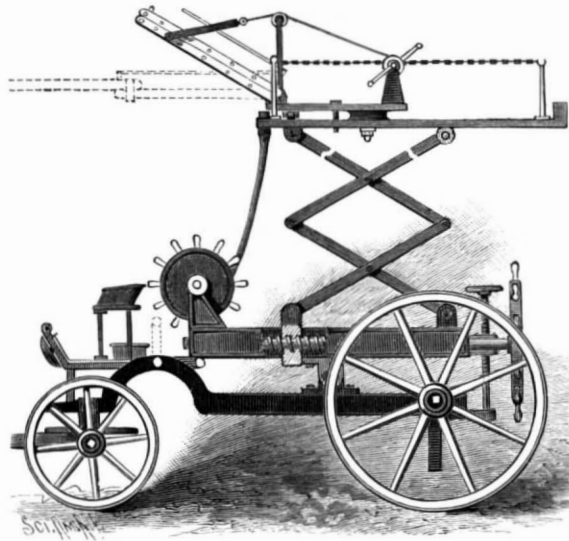

HENNESSEY'S FIRE ESCAPE AND WATER TOWER.

frame is a reel, one end of the shaft of which is hollow and adapted for connection with a water pipe, the inner end of the shaft being connected with a hose wound on the reel, and the outer end of the hose being connected with a threaded pipe in the platform raised by the lazy tongs, the latter pipe being adapted to receive a hose nozzle for the use of the firemen. The lazy tongs, when in extended position, are preferably steadied by guy rods or ropes leading to the ground.

BATCHELOR'S RIPPING ATTACHMENT FOR SEWING MACHINES.

The illustration represents a simple device readily attachable to a sewing machine table and operated by a lever connected with the needle bar for rapidly ripping seams or cutting material. It was patented in July last by Francis M. Batchelor, of Portland, Oregon, and, as will be seen by the accompanying letter, this inventor has sold his patent for a handsome sum of money. The following letter speaks for itself:

American Steel Company,
Portland, Oregon, March 6, 1897.

Messrs. Munn & Company.

Gentlemen: I am pleased to advise you that I have just sold my United States patent, No. 569,827, which you obtained for me on the 28th of last July, for \$50,000 spot cash.

If it will do you any good or be of any interest to your readers, you are at liberty to use this information in any of your several publications.

Very truly yours,

F. M. BATCHELOR.

Fig. 1 is a sectional side view and Fig. 2 is a plan view of the improvement, the knife, A, sliding in a

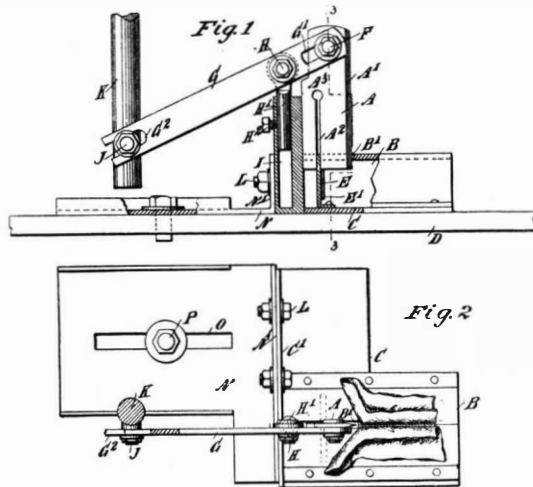

SEWING MACHINE RIPPER—A \$50,000 INVENTION.

in the apex of a peak-shaped rest, B, secured on a table, C, resting on a sewing machine table, D. The material to be ripped or cut is advanced on the apex of the rest against the cutting edge of the reciprocating knife. The latter is guided in its up and down movement by a guide, E, engaging a vertical slot, A², in the blade, and in the upper end of the knife is a pivot, F, engaging a

slot in a lever, G, fulcrumed and held vertically adjustable at the upper end of a post, H. The outer end of the lever has an elongated slot engaging a stud, J, secured on the needle bar, K. The table carrying the ripping attachment may be readily adjusted and secured in proper position on the sewing machine table.

We desire to congratulate Mr. Batchelor upon the success he has attained with his patent. His letter was sent to us without any solicitation on our part.

The Hippocratic Oath.

A correspondent of the Medical Record seeks information regarding the Hippocratic oath, taken by physicians upon graduation.

He states that he has inquired as to the substance of this oath of many physicians, who have been unable to give him a satisfactory answer. It is highly probable that but a few of our best educated physicians ever knew the text of the oath they were taking. The Medical Record gives the following translation of the oath in full:

"I swear by Apollo the physician, and Æsculapius, and Health, and All-heal, and all the gods and goddesses, that, according to my ability and judgment, I will keep this oath and this stipulation—to reckon him who taught me this Art equally dear to me as my parents, to share my substance with him, and relieve his necessities if required; to look upon his offspring on the same footing as my own brothers, to teach them this art, if they should wish to learn it, without fee or stipulation; and by precept, lecture, and every mode of instruction, I will impart the knowledge of the Art to my sons, and those of my teachers, and to disciples bound by stipulation and oath according to the law of medicine, but to none others. I will follow that system of regimen, according to my ability and judgment, I consider for the benefit of my patients, and abstain from whatever is deleterious and mischievous. I will give no deadly medicine to any one if asked, nor suggest any such council; and in like manner I will not give to a woman a pessary to produce abortion. With purity and with holiness I will pass my life and practice my Art. I will not cut persons laboring under the stone, but will leave this to be done by men who are practitioners of this work. Into whatever houses I enter, I will go into them for the benefit of the sick, and will abstain from every voluntary act of mischief and corruption, and, further, from the seduction of females or males, of freemen and slaves. Whatever in connection with my professional practice or not in connection with I see or hear, in the life of men, which ought not to be spoken of abroad, I will not divulge, as reckoning that all such should be kept secret. While I continue to keep this Oath unviolated, may it be granted to me to enjoy life and the practice of the Art, respected by all men, in all times. But, should I trespass and violate this Oath, may the reverse be my lot."

Laws of Teaching.

1. There is no school unless the father, the mother, the teacher, and the pupil keep school together.
2. Know thoroughly the subject to be taught and explain to the pupil why you teach it.
3. Gain and keep the attention of the pupils. Excite their interest.
4. In your teaching use language that your pupils understand.
5. Begin with the known and go by easy steps to the unknown. Take the whole class with you!
6. Excite self-activity in the pupils and lead each to discover truth. Show the class how to study.
7. In each lesson let a halt be made and then have pupils fix points already made, the conclusions reached, and the premises upon which the conclusion is based.
8. The teaching must touch the whole nature of the child and stimulate to higher action and more industrious habits of work, of silence, of obedience, honesty and truthfulness. Three-fourths of education is a habit of work.—J. M. Greenwood in Midland Schools.

A Quick Piece of Work.

One of the quickest pieces of work on record in the way of installing a ventilating plant was recently completed at Harrisburg, Pa., says the Engineering Record. It may be remembered that the building containing the assembly rooms of the Senate and House of Representatives at the State Capitol was destroyed by fire on February 2. An unoccupied church was temporarily secured, but this building being without a suitable heating plant or any ventilation whatever, it was necessary to install a new plant before the building could be occupied. Accordingly, an order was telegraphed on February 4 to a blower company, instructing them to ship two 6,000 foot coils with 60 inch fans as soon as possible. One apparatus was placed on board the cars within twelve hours and the duplicate within thirty hours from the receipt of the order. In the meantime, a large force of men was at work on the ground, putting in the foundations, steam mains, and air piping required for the apparatus. The heating plants were completed and the building ready for occupancy within one week from the date of the fire.

RECENTLY PATENTED INVENTIONS.

Engineering.

SMELTING FURNACE.—Charles Bishop, Tacoma, Washington. For fusing all kinds of ore, using oil as the fuel, and with or without charcoal mixed in the ore, this inventor has devised a furnace whose combustion chamber has its bottom formed into a chamber to receive the molten metal, the grate being at the lower end of the stack and in an inclined position over the combustion chamber, into which discharge a number of fire boxes connected with an oil supply. The lower end of the grate projects into a slag discharge which leads to the outside of the furnace.

Railway Appliances.

SWITCH.—D. Fred Carver, Brooklyn, N. Y. This invention relates to switches in which the main line rails have a continuous and uninterrupted tread through the switch, and the invention prevents the wheels from cutting into the rails. The main rails are spread wider than the normal gage and a riser is placed between the normal and widened gage lines for receiving the wheel flanges, a second riser being provided for the tread of the wheel. The second riser, which leads to the siding, overlaps the main rail tread. Various novel details are also provided. The risers and auxiliary devices are designed for the inside of the curve, the switch tongue, which is the only movable part of the switch, being at the outside curve.

SWITCH OPERATING DEVICE.—Wilson A. Clapp, Pittsfield, Mass. This is a simple and inexpensive device, applicable to any form of sliding switch, whereby the switch may be opened or closed from a moving train, and at a distance in advance of the train entering the switch. The mechanism for operating the shifting or trip devices may be readily applied to an engine or car without interfering with any of its working parts. The switch is adapted to be set automatically by means of a trip bar held in a hanger below the engine, or the device may be operated by means of a hand lever.

CAR BRAKE.—John W. Buford, Jr., Jackson, Tenn. This brake is designed to remain automatically applied while the car is at rest or while the engine is not pulling, but will be released the moment the car is started ahead. In descending an incline the brakes may be applied only partially, and when it is necessary to back a car the brake pressure may be taken off entirely. A shifting lever is furnished beneath the car in connection with a longitudinally slidable shaft, there being two brake beams between which is located a spring pressing the beams apart to normally apply the brakes, there being means for drawing the brake beams apart against the tension of the spring and a connection between the beams and a shifting lever.

PARLOR AND SLEEPING CAR.—James M. Osgood, Boston, Mass. This inventor has devised an improved car in which the chairs or seats employed for day use may be readily converted into sleeping berths so arranged that the berths of a section will overlap each other to a certain extent. The several sections of the car are also provided with separating partitions that may be compactly folded in the side framing of the car in the day time and extended transversely in connection with the berths at night. An intermediate partition divides a section into two compartments for night use, and the seats or chairs are so attached to the floor that they may be all moved to one end, thus making a reception room of the body of the car. Further details relative to this invention may be had by application to the Osgood Car Company, 37 Tremont Street, Boston, Mass.

Electrical.

TELEGRAPH REPEATER.—Charles W. Leiser, Carlinville, Ill. A cheap and efficient instrument is provided by this inventor, one that needs but little care after being once adjusted to the circuits over which it is to be worked. It comprises two relays provided with armature levers, each having two spring contacts furnished with limiting pieces, two stationary contact points for each armature lever, two batteries connected with the main lines and with the forward stationary contacts of the relays, while the electrical connections, the relays and their armatures, are oppositely arranged with respect to each other. The instrument may be constructed of common telegraph relays at small cost, obviating the necessity of building special new instruments.

Mechanical.

PIPE WRENCH.—William H. Furbee and Thomas Barrett, Mannington, West Va. This is an improvement in what are known as chain wrenches, the chain being held at one end to the handle and having at its other end a gripping link, a portion of the handle being arranged to engage and operate the gripping link. When once adjusted it may be used on a considerable range of sizes of pipes, the nose or projection of the handle tilting the gripping link to properly engage the pipe, while a ball holds the link to the head of the wrench without interfering with the link by the swinging of the handle.

EXHAUST FAN.—Samuel Rembert, Memphis, Tenn. This is an improvement in fans designed to facilitate the conveyance through piping of seed cotton, cotton seed, etc., and the construction is such as to avoid injury to the conveyed material by contact with the blades of the fan. The fan casing has a lateral inlet, and held to and revolving with the fan is a perforated guard, which is arranged between the blades and the side of the case having the inlet opening, thus forming a passage for the cotton along the guard and between it and the case, while the turning of the guard plate facilitates the flow of the material.

CIGARETTE BOX MACHINE.—Domingo Perez y Bunol, Havana, Cuba. This machine not only makes the boxes but packs the cigarettes. It comprises a series of mechanisms acting together to form a sheet of paper into the shape of a box, then introduces the articles to be packed in the boxes and closes the latter. A paper or cardboard feed device supplies periodically the necessary material for each box, a cutter dividing the

material into pieces of the right size and shape, when a conveyor carries the cut pieces to a former which makes the shape of the box, which is then carried to a position to receive the articles to be packed. The cigars, cigarettes, or other articles to be packed are mechanically arranged in regular lines or rows before being conveyed to the unfinished box.

OPERATING JIG PLUNGERS.—Adren L. Heaston, Bingham Canon, Utah. In ore concentrating jigs this invention provides a device for operating the plungers in such manner that a quick drop is given to the plunger to cause the water to be dashed upward with great force through the screen to readily separate the valuable particles from the tailings. The plunger is secured to a lever pivoted on the tank, and near its pivoted end, the long arm of the lever being slowly raised by a cam, and quickly returned by a spring, thus throwing the water upward against the material contained in a sieve.

PIPE COUPLING AND FITTING.—William H. Le Chard and John A. Best, Atlantic City, N. J. In long screw pipe couplings and fittings intended to withstand high pressure, this invention provides the threaded portions with plain surfaces whereon are compressed soft metal collars for packing and making tight joints, such packing collar being kept always at hand when the sections are coupled or uncoupled. The sockets, locks or jamb nuts employed, and also the mouth portions of the fittings, are so shaped that the soft metal collars will be effectually compressed between such opposing surfaces, the collars being wider at their inner than their outer peripheral surfaces.

Agricultural.

FARM GATE.—George W. and John E. Lilly, Sedalia, Mo. This invention is for an improvement in horizontally swinging gates adapted to close automatically by gravity, and whose free ends may be adjusted as required to swing over stones or other obstructions, such adjustment also facilitating the separating of small domestic animals, as sheep and swine, from larger ones, as horses and horned cattle. The gate is formed of horizontal slats and pivoted vertical connecting bars, and hinged alongside is a triangular device formed of a right angular rod and a tension rod, while a toothed plate secured vertically to the gate proper engages the pointed end of the device.

Miscellaneous.

AERIAL PHOTOGRAPHIC APPARATUS.—William A. Eddy, Bayonne, N. J. In apparatus to be carried by a kite string to properly support photographic cameras for taking negatives of the surroundings from a great altitude, this inventor has devised a novel form of hanger, which, with a boom extended from its lower end, are connected with the kite string, the hanger supporting a platform to which the camera holder is hinged, there being means for elevating the rear end of the holder, over which also extends a hinged arm adapted to engage the shutter operating button, and a string extending downward from this arm to the ground. By drawing on this string the shutter of the camera is operated to make the exposure at the desired time. The platform may carry several cameras, the strings being connected and all simultaneously operated in the same way.

SEWING MACHINE HEMMER.—Mary R. K. Fowkes and Mary E. J. Bennett, Selma, Ala. The improved hemmer devised by these inventors is designed to produce hems of any width, from one-fourth of an inch to eight inches, and it may be applied with very slight changes to either lock stitch or chain stitch machines. The improvement comprises a base plate with front slot and parallel graduations, in combination with a slotted gage bar with foot, a cross bar with clamp bolt secured in the slot of the base plate and a separate hem turner.

TYPEWRITING ATTACHMENT FOR ADDING MACHINES.—George W. Dudley, Charleston, West Va. Two patents under the foregoing title have been granted this inventor for improvements upon an invention formerly patented by him, according to one of which it is intended to extend the scope of the machine by providing it with a fully equipped alphabet, with numerals and characters, adapting the machine for making statements of accounts and doing all kinds of clerical work involving the use of letters or figures. The object of the invention covered by the other patent is to enable the combined adding and printing machine to operate upon and print directly on blank books, such as bank books, pass books, etc., and to this end the printing carriage and its associated parts are reorganized to enable the blank book to be readily placed in the machine and the extensions, and the totals to be printed directly on the pages.

ICE CREAM FREEZER.—George S. W. Brown, Athens, Pa. This is a household appliance comprising the freezer, a tank for storing the cream when frozen, an ice water tank or refrigerator, all built in cheap and compact form, and designed to be of great utility. Within the frame of the freezer is a revolving freezing cylinder, and the mixture that is to be frozen is held in a receptacle that is vertically adjustable in relation to the cylinder, a scraper being suspended from the frame so as to bear against the cylinder, scraping off the frozen cream and allowing it to drop into a receptacle below.

FILTER.—Edon A. Brashear, Western Port, Md. This filter has a central inlet at its bottom and a central filtered water chamber opening at the bottom into a surrounding sand space, there being two vertically adjustable concentric tubes forming an upward passageway for water and sand, and both tubes being open at their lower ends and forming a compound valve with the bottom of the filter to cut off the sand by their successive action, while forming a tight joint. The filter is designed for household purposes or larger uses, and the sand used as the filtering medium may be agitated and cleansed from time to time by the admission of water under pressure.

LAMP.—William H. Kincaid, Santa Barbara, Cal. According to this invention, a series of inwardly converging reflectors is grouped around a cen-

tral light, while transparent panes are located exteriorly of the reflectors and extending from the back of one reflector toward the reflecting face of the adjacent reflector. The lamp frame consists of two sections connected by a vertical hinge joint, and a series of light reflectors secured to the frame is grouped around the central light, whereby the rays are first concentrated and then directed to properly light the streets, instead of diffusing the light all around, and unnecessarily lighting objects in the immediate neighborhood of the lamp.

BASKET.—William R. Yerby, Athens, Ga. This invention is for a cheap and durable basket designed especially for farm use in the gathering of products, the basket being readily made without the use of skilled labor. It is composed of an open rectangular framework, held together by brace wires, while a bag having pockets at its upper edges receives the four upper bars of the frame, the bottom of the bag being engaged by penetrating points and supported on the wires.

BELT FASTENER.—Jonathan Hill, Jersey City, N. J. This is a fastener for machine driving belts, consisting of a locking bar terminating in heads, washers passing over the heads of the bar and a key passing through the washers and engaging the straight side face of the locking bar. The fastener is readily applied to connect the ends of a belt, the locking bars and keys being given a curved form when the belt is placed on a pulley, and the point of a junction forming a ridge extending away from the pulley.

DOOR SPRING AND CHECK.—Christian Bayer, New York City. A swinging arm is mounted on the door casing, according to this invention, there being a barrel on the free end of the arm and in the barrel a rotating block through which extends a rod connected with a shaft designed to rotate on the door, there being a spring connected at one end to the shaft, and a chain extending from the other end of the spring around the barrel on the arm. The construction is simple, and the device is not liable to get out of order, while it operates effectively to close doors without slamming them.

TRACE CARRIER.—Edward A. Cotham and George Wells, Monticello, Ark. This invention is for a buckle especially adapted for use on the backband of a harness, there being on the buckle a safety snap or its equivalent adapted to be attached to the trace, such snap or other device having a swivel connection with the buckle to prevent chafing or rubbing the sides of the horse.

HORSE DETACHER.—James H. Dunnington, Washington, Pa. This is an attachment for the front axle of the vehicle, and also the thills, the portion connected with the thills being readily disconnected from the portion attached to the axle to permit the forward or thill carrying section to be quickly disengaged, and thus admit of the instant release of an unruly or runaway horse. The device is very simple and inexpensive, the disengagement of the animal being effected by pulling on a cord extending to convenient reach of an occupant of the vehicle.

NOTE.—Copies of any of the above patents will be furnished by Munn & Co. for 10 cents each. Please send name of the patentee, title of invention, and date of this paper.

NEW BOOKS, ETC.

THEORY AND CALCULATION OF ALTERNATING CURRENT PHENOMENA. By Charles Proteus Steinmetz, with the assistance of Ernst J. Berg. New York: The W. J. Johnston Company, 253 Broadway. 1897. Pp. xvii, 431. Price \$2.50.

In this work we have a very valuable contribution to what may be properly termed the greatest development of the new electricity. The title discloses its subject, which is treated by a high authority. Dr. Steinmetz has long been known as one of our best electrical mathematicians, and in this work at last we have his contribution to the world's work issued in really good shape. The time has gone by when electricity can be treated entirely from the practical aspect. Theory is absolutely required, and the mathematical treatment given to the different theoretical studies is imperative. Formerly the higher mathematics were kept out of electrical books as far as possible, but the new school of educated electricians, well versed in analytical mechanics and in the calculus, will hope to find in such works as that of Dr. Steinmetz a precursor of many others.

DIE KRAFTUEBERTRAGUNGS-WERKE RHEINFELDEN. Technische und Wirtschaftliche Darstellung der Ausnutzung der Wasserkraft des Rheins bei Rheinfelden. Herausgegeben von der Allgemeinen Elektrizitäts-Gesellschaft. Berlin: Druck von H. S. Hermann. 1896. Pp. 173.

Transmission of power has received great attention in Europe, and electricity has lent itself to the work with great effect. This monograph is devoted to the river Rhine as a source of power and to the development of the power depending upon its flow. It treats of a most important enterprise in the use of water power and electrical energy. It is profusely illustrated and well printed, and gives the details of the work in several general divisions, such as water power, the generation of electric energy, its transmission and utilization.

BERLIN UND SEINE BAUTEN. Berlin: Wilhelm Ernst & Sohn. 1896. Three parts in two volumes, 1550 pages, 2150 illustrations in the text, 18 plates and 5 maps. 4to. Price stitched, \$15 exclusive of importation expenses.

This work is very comprehensive in its scope and deals with every department of architecture and all kinds of public works in the city of Berlin and its chief suburb, Charlottenburg. Owing to the fact that Berlin is the seat of county and provincial authorities as well as of those of the Prussian kingdom and of the German empire, the number of public buildings is very large. The municipality also is world famed for the thoroughness and effectiveness of its work. The publication above re-

ferred to gives us an excellent review of the various public buildings, such as the new parliament building and the cathedral, which is being constructed, the various institutions of learning and office buildings as well as residences. Special chapters are devoted to descriptions of the parks, the streets and squares, canals, bridges, street railways and other means of communication. The systems of water supply and of sewerage, the lighting of the city, the fire brigade and the street cleaning department are fully treated. The book also gives an account of the industries represented in Berlin, as well as of the markets and other buildings provided by the municipality for the convenience of the public. The illustrations are excellent and numerous, and the work is highly creditable to the publishers as well as to the editors.

THE A B C OF THE X RAYS. By William H. Meadowcroft. New York: The American Technical Book Company. Pp. 189. Price in paper 50 cents, cloth 75 cents.

The present work by the author of another well known book bearing in part the same title will, we are convinced, be very acceptable to many. The book is excellently illustrated, well printed and has a very satisfactory index. The radiograph, with accompanying photograph of a mummy's hand, that of an Egyptian princess, may be cited as an example of the illustrations, some of which in half tone work are of unusual clearness.

TABLES FOR THE QUANTITATIVE ESTIMATION OF THE SUGARS. With explanatory notes. By Dr. Ernst Wein. Translated, with additions, by William Frew. London: E. & F. N. Spon. New York: Spon & Chamberlain. 1896. Pp. xiv, 128. Price \$2.40.

This work in the original German has been very widely used both in Germany and America by sugar chemists, and is regarded by them as a standard work on this subject. It is largely made up of tables, only enough text being introduced to explain them, so that it amounts in great part to a reprint of an important set of tables for practical use, the text and headings being translated and the whole put into English dress.

THE COMMERCIAL ORGANIZATION OF FACTORIES. A handbook for the use of manufacturers, directors, auditors, engineers, managers, secretaries, accountants, cashiers, estimate clerks, prime cost clerks, bookkeepers, draughtsmen, students, pupils, etc. By J. Slater Lewis. London: E. & F. N. Spon, 125 Strand. New York: Spon & Chamberlain, 12 Cortlandt Street. 1896. Pp. xxxvi, 540. Price \$12.

We have to rely upon the title of this book to tell to some extent the ground it covers. It treats of the management of the force of a factory and of the use of the different kinds of time registering systems. In some places it affords somewhat curious reading, the English system of personal interference being quite strongly brought out in some of the provisions. In it is elucidated at great length many systems of conducting the different departments of an establishment. As an example we would refer to the portion devoted to the ticket system of keeping exact account of the work done by each man, of the time wasted by him, of his late comings, etc. The illustrations of the book are numerous—including the shape and inscriptions of checks for time, of paper slips, of tickets and bill heads. Certainly it is curious to see the workings of a factory brought down to so scientific a basis as that indicated.

DIE SIEDESALZ-ERZEUGUNG VON IHREN ANFAENGEN BIS AUF IHREN GEGENWAERTIGEN STAND NEBST EINEM ANHANGE UEBER SEESALINEN. Von Carl Baltz, Elder von Balzberg. Berlin: Wilhelm Ernst & Sohn. 1896. Pp. 159. Also an atlas of 19 plates. Price \$8.

This is a very exhaustive work on the methods and apparatus for the production of salt from salines. The subject is treated in a very interesting manner, the chronological order being followed in most of the chapters of the book. Although continental European procedures are described with most detail, still improvements due to Englishmen and Americans are not omitted, so that the author may rightly claim to have produced a thoroughly complete work. So far as we know, no similarly exhaustive work has been published hitherto, and the fact that the book received the highest award in a prize competition is further evidence as to its thoroughness. All improvements made since 1860 are described very fully, the apparatus for boiling, drying, and purifying the salt being treated with considerable minuteness. A separate chapter is devoted to methods introduced at a comparatively recent time, such as the hot air method, the cooling method, the vacuum method, the Rittenger-Picard method, also the production of salt by utilizing the heat of the sun's rays. Another chapter treats of the various uses to which salt is put in the household and in different industries and arts. This chapter is particularly interesting. The production of salt from sea water forms the subject of the last part of the book, and there is appended a catalogue of works bearing on the matter treated in the book, so that reference to the original works utilized is made very easy.

Education by Correspondence.—We have received the 1897 catalogue of the International Correspondence Schools, Scranton, Pa. The catalogue contains a description of the courses of instruction in the schools and states the methods by which the work is conducted and a history of the institution. Correspondence schools are not intended to take the place of regular institutions of learning, but in many cases the correspondence school admirably meets the requirements of those who for the want of time and means cannot attend regular schools where scientific and technical subjects are taught. The instruction papers are sent out and questions are furnished which the student must answer. When a set of answers is received by the school it is examined, corrected, and returned with such suggestions and criticisms as will enable the student to understand the subject thoroughly.

Business and Personal.

The charge for insertion under this head is One Dollar a line for each insertion; about eight words to a line. Advertisements must be received at publication office as early as Thursday morning to appear in the following week's issue.

- Marine Iron Works. Chicago. Catalogue free.
"U. S." Metal Polish. Indianapolis. Samples free.
Yankee Notions. Waterbury Button Co., Waterbury, Ct.
Handle & Spoke Mch'y. Ober Lathe Co., Chagrin Falls, O.
Improved Bicycle Machinery of every description. The Garvin Machine Co., Spring and Varick Sts., N. Y.
Concrete Houses - cheaper than brick, superior to stone. "Ransome," 757 Monadnock Block, Chicago.

Foreign Worrall Clutch Patents for sale outright or on royalty. Great success in United States. Address American Twist Drill Co., Laconia, N. H., U. S. A.

The celebrated "Hornsby-Akroyd" Patent Safety Oil Engine is built by the De La Vergne Refrigerating Machine Company. Foot of East 138th Street, New York.

The best book for electricians and beginners in electricity is "Experimental Science," by Geo. M. Hopkins. By mail, \$4. Munns & Co., publishers, 361 Broadway, N. Y.

Send for new and complete catalogue of Scientific and other Books for sale by Munns & Co., 361 Broadway, New York. Free on application.

Notes & Queries

HINTS TO CORRESPONDENTS.

Names and Address must accompany all letters or no attention will be paid thereto. This is for our information and not for publication.

References to former articles or answers should give date of paper and page or number of question.

Inquiries not answered in reasonable time should be repeated; correspondents will bear in mind that some answers require not a little research, and, though we endeavor to reply to all either by letter or in this department, each must take his turn.

Buyers wishing to purchase any article not advertised in our columns will be furnished with addresses of houses manufacturing or carrying the same.

Special Written Information on matters of personal rather than general interest cannot be expected without remuneration.

Scientific American Supplements referred to may be had at the office. Price 10 cents each.

Books referred to promptly supplied on receipt of price.

Minerals sent for examination should be distinctly marked or labeled.

(7135) M. P. S. writes: In your issue of January 16, under the head of Science Notes, you state the coldest region on earth is the country around Werchsjansk, in Siberia, where the thermometer sometimes falls below 68° Centigrade below zero (90° Fah. below zero). Are you not in error when you say 68° C. = 90° Fah.? Does not 68° C. = 154½° Fah.? The formula is ½ C. + 32 = Fah., or at least I was so taught. A. The article you refer to is correct. The degrees below 0° C. are minus quantities, so that the addition, being algebraic, involves an arithmetical subtraction. Those not conversant with algebra, for degrees below 0° C. may proceed as follows: If the result of the multiplication of degrees below zero Centigrade by ½ is (a) less than 32, subtract it from 32; if (b) greater than 32, subtract 32 from it. The result of a is to be expressed as degrees above zero Fah.; the result of b is to be expressed in degrees below zero Fah. But treated algebraically the formula is correct. Thus -68 x ½ = -122½; adding 32 we have -122½ + 32 = -90½. This process gives a fraction more than 30° Fah. below zero as the equivalent of the Centigrade degrees, which corresponds with the article, except that the fraction is omitted, as of inconsiderable amount.

(7136) G. F. H. writes: 1. Is there a compound, not poisonous, which, when paper is moistened with a solution of it and a current of electricity passed through the paper, will give the same or similar result as is obtained by like treatment of paper moistened with a solution of ferro-cyanide of potassium? That is, will there be traced on the paper a permanent blue line or a distinct line of any color? A. A solution of potassium iodide acts thus. A very dilute starch solution may be added to the iodide solution to intensify the color. 2. Can paper be so treated as to become a conductor when dry, the current being of the strength of one gravity cell? If so, what is the treatment required? A. No; except by brazing or coating with black lead or some such treatment. The conducting powers of paper charged with chemicals, as used in chemical telegraphic recorders, is due to the presence of moisture.

(7137) R. G. R. asks: 1. I have a motor having a ring armature about ¾ inches in diameter. The armature is wound with about No. 24, the field with about No. 10, speed 2,200 revolutions, volts 6. Now I want to convert it into a dynamo. How am I to reduce the speed? A. Do not attempt to reduce the speed, but run with large belt wheel on countershaft so as to maintain a speed of 2,000 to 3,000 revolutions per minute. You may not get much satisfaction from it, as a motor is often poorly adapted for use as a dynamo. 2. Why will not the current from an induction coil run a motor? A. It will run a special motor adapted for high tension electricity. It will not run an ordinary motor, because it produces an almost infinitesimal current of alternating and very high frequency type at enormous potential, while ordinary motors are adapted for currents of widely different character. 3. Should the above described motor run connected as a shunt? A. Yes.

(7138) A. H. C. says: Can you inform me where I can get a cement which is not soluble in alcohol and that will hold glass? A cement, for example, that would mend a glass whisky or brandy flask so that it would hold liquor. A. Take the best kind of glue; pour on an equal quantity of water; let it soak overnight; next morning melt it over a gentle heat, and add fine Paris white or white lead; mix well, and add a little acetic acid, carbolic acid, oil of cloves, or any other ethereal oil, to prevent putrefaction. This cement is

also adapted for flexible objects like leather. It will not withstand boiling water well, as this softens the glue.

(7139) E. G. B. asks for a recipe for making grafting wax. A. Grafting wax:

- 1. Pitch..... 4 oz.
Resin..... 4 "
Lard..... 2 "
Beeswax..... 2 "
Melt over a slow fire, or
2. Melt together equal quantities resin and beeswax, and add enough tallow to produce the proper consistency.
Grafting wax:
3. Pine resin..... 50 parts.
Tallow..... 10 "
Turpentine..... 5 "
Alcohol, 90 per cent..... 5 "

The resin is melted in an iron vessel. The turpentine is added, next the tallow, and finally the 90 per cent alcohol. Stir the ingredients thoroughly and cool.

(7140) H. J. F. asks: 1. Can I deposit zinc upon carbon plates? If so, how and what is the process? Can you furnish me formula for above? A. Zinc can be deposited on them electrolytically. See our SUPPLEMENT, Nos. 994, price 10 cents by mail. 2. I have constructed a battery, using carbon and zinc for elements, exposing to the action of the solution 96 square inches, and obtain 8 volts for about one hour, and after that time it drops about 35 per cent per hour. Can you recommend a solution that will give longer life? I do not care as to the consumption of zinc. A. As regards your battery, if you have used good bichromate solution, no improvement can be suggested, unless it is to use larger vessels, so as to have more solution. We assume that your zincs are well amalgamated; neglect of this will make the battery very short lived. 3. How much power can I derive from 8 light dynamo used as a motor? A. The dynamo named should give over ½ horse power. 4. Can I not use the 8 light dynamo described in SUPPLEMENT as a motor to run a 20 foot boat and run same by battery? A. The dynamo could be so used. You should use storage batteries. 5. What is the output of dynamo in watts? A. About 50 watts. 6. What kind of battery do you recommend and how many for a two gallon electroplating apparatus? A. Eight or ten gravity batteries. See our SUPPLEMENT, No. 310, for electroplating.

(7141) H. B. asks: 1. Which is the best battery to use in electroplating, or why is the Smee or Bunsen used more extensively than the gravity? Could not the first be used? A. The high resistance of the gravity battery tells strongly against its use for electroplating. On the other hand, its great constancy is much in its favor. There are no absolute grounds in favor of any one kind of battery. Each kind has its good and bad points. 2. Would it cost more to use a gravity cell than a Smee or Bunsen, as the first has to be closed four or five hours a day, the Smee or Bunsen being used from one-half to two hours? A. The gravity cell can be run perhaps cheaper than any other. If the upper two or three inches of solution are withdrawn by a large India rubber syringe when the battery is out of action, the closing of the circuit will not be required. 3. How is the gold solution used in plating made? Also the silver? A. See our SUPPLEMENT, No. 310, price 10 cents by mail. 4. What shape and weight are the gold and silver anodes usually? A. Plates are used of area proportional to work. The weight has no effect on the action. 5. In a storage battery and on a dynamo, which is the positive and negative terminal? In charging a battery, how are the terminals connected? The negative and negative or the positive and negative? A. The purple colored plate of a storage battery is termed the positive. It corresponds to the copper or carbon plate in a primary battery. For charging connect the cells in series, positive to negative. 6. When lead is substituted for the copper in the gravity cell, does it need to be insulated where it comes through the two solutions? A. The lead plate should not come through the two solutions. It should lie at the bottom of the jar in the copper sulphate solution. A gutta percha insulated lead or copper conductor should connect with it and lead out of the battery jar.

(7142) J. McL. writes: 1. What is the difference between American wire gage and Brown & Sharpe's gage? A. They are identical. 2. If I make electric motor described in "Experimental Science" one-half size, what change would I have to make in the wire and what part of the original power would I get? A. It would give you about one twenty-fifth of the power of the larger dynamo. The sizes of wire would be determined by the voltage desired. 3. Where can I get a good description of how to make a sensitive galvanometer, not the mirror type? How can I make a tangent galvanometer without having resistance coils? A. For galvanometers we refer you to SCIENTIFIC AMERICAN, No. 12, vol. 61, also SUPPLEMENT, No. 794; price 10 cents each prepaid by mail. Resistance coils form no part of a galvanometer; they are used in connection with it to determine resistance of conductors. 4. How is the magnetic meridian found in using a tangent galvanometer? A. By the compass needle. Set the instrument so that the needle points to 0 on the scale.

TO INVENTORS.

An experience of nearly fifty years, and the preparation of more than one hundred thousand applications for patents at home and abroad, enable us to understand the laws and practice on both continents, and to possess unequalled facilities for procuring patents everywhere. A synopsis of the patent laws of the United States and all foreign countries may be had on application, and persons contemplating the securing of patents, either at home or abroad, are invited to write to this office for prices, which are low, in accordance with the times and our extensive facilities for conducting the business. Address MUNN & CO., office SCIENTIFIC AMERICAN, 361 Broadway, New York.

INDEX OF INVENTIONS

For which Letters Patent of the United States were Granted MARCH 16, 1897,

AND EACH BEARING THAT DATE. [See note at end of list about copies of these patents.]

Table listing inventions such as: Adding and registering mechanism, C. H. Little. 579,115; Adding machine typewriting attachment, G. W. Dudley. 579,047; Alarm. See Burglar alarm.

Table listing inventions such as: Game counter, Pool, F. B. Wood. 578,906; Garbage can, G. W. Walker. 578,957; Gas burners, by-pass valve for, Welsbach or other incandescent, G. S. Barrows. 578,711; Gas generator, acetylene, J. H. Couper. 578,972; Gas generator, acetylene, C. H. Wilcox. 578,847; Gas lighting, J. B. de Lery. 578,954; Gas manufacturing apparatus, W. H. Harris. 579,110; Gas meter, E. B. De La Matry. 578,863 to 578,865; Gate, R. K. Ball. 578,709; Gate, T. Sawyer. 578,949; Gear wheel and mechanism for making same, wrought metal, U. & F. L. Eberhardt. 578,731; Generator. See Gas generator; Glass grinding and polishing machine, P. Semmer. 578,779; Gold from ores, extracting, H. R. Cassel. 578,720; Gold from ores, process of and apparatus for extracting, B. C. Hinman. 578,746; Gold separator, hydraulic, Barr & Johnson. 578,807; Grain discharging attachment, M. P. Kneif. 578,754; Grain, rotating cylinder for germinating and drying, J. A. Tilden. 578,845; Grape shears, V. W. Kelly. 578,093; Grease separator, W. J. Baldwin. 578,708; Grinding and scouring apparatus, S. D. Coates. 578,969; Gun, magazine arr., E. R. Hauer. 578,820; Gun, bolt stop, W. Parlay. 578,906; Gun, for bolt, W. P. Laraway. 578,877; Half rounds, apparatus for making, J. W. Hussey. 578,877; Hand grip, Wiens & Brands. 578,959; Hand shield, S. F. Farke. 578,852; Handle. See Bicycle handle; Hanging, ornamental, C. W. Jackson. 578,878; Heater. See Feed water heater; Heater and ventilator, Johnson & Ensign. 578,903; Heater attachment, I. Brooke. 578,808; Hook. See Checkrein hook. Lacing hook. Horseshoe, H. H. Dunnington. 578,979; Hose bridge, railway, C. A. & C. J. Grimes. 578,051; Hose support, O. Bagley. 578,951; Hydrocarbon engine, E. Merry. 579,048; Ice cream freezer, G. S. W. Brown. 579,040; Ice cream mould, C. Memcke. 578,889; Incandescent light fixture for railway cars, etc., S. B. Faraday. 578,735; Incandescent mantles, process of and apparatus for hemming ends of, E. Skriwan. 578,841; Index making apparatus, W. W. Le Seur. 578,935; Indicator. See Water indicator; Ink ribbon mechanism, D. E. Felt. 578,919; Insecticide, H. Danforth. 578,862; Insulator, Luscomb & Crane. 578,825; Jack for seating tie plates, P. Hale. 578,869; Jig plungers, device for operating, A. L. Heaton. 578,988; Joint. See Railway rail joint; Journal bearing, J. H. Christopher. 579,041; Jute, machine for defiberizing compacted, R. C. Menzies. 578,890; Knife. See Orange knife; Knob spindle fastener, J. S. Randall. 579,078; Lacing hook, E. Kempshall. 579,112; Lamp, W. H. Kincaid. 578,931; Lamp burner, L. Hammon & Loebbeck. 578,975; Lamp burner, Smith & Isgrig. 579,018; Lamp, electric arr., T. E. Adams. 579,032; Lantern, Brown & Fowler. 578,922; Lantern, railway, E. M. Barbeau. 578,948; Lath and A. bars, A. Johnson. 578,852; Lighting device, J. C. Garnier. 578,914; Lightning arrester, W. K. Freeman. 578,981; Liquid mixing apparatus, A. Gates. 579,055; Liquids containing carbonic acid, apparatus for drawing off, A. Krepmer. 578,884; Load binder, H. Bradley. 578,855; Lock. See Seal lock; Lock, W. S. Nash. 578,763; Log turner, C. E. Clark. 578,723; Lubricator, E. McCorkindale. 578,758; Lubricator, L. C. Pond. 579,068; Lumbar rest, J. B. Pope. 578,979; Magazine, Breamer, E. G. Parkhurst. 579,097; Manure carrier, D. B. Cherry. 578,722; Match cabinet, S. Green. 578,818; Match making machine, J. C. Donnelly. 578,727; Meat cutter, rotary, F. H. Pierpont. 578,942; Meat safe for butchers, etc., P. Hammon & Loebbeck. 578,822; Metals and alloys producing, H. Goldschmidt. 578,968; Meter. See Electricity meter. Gas meter; Meter seal, H. Ringness. 578,775; Milk, cream, etc., apparatus for sterilizing, A. T. Pfeiff. 578,899; Mining engine, P. Block & McLaughlin. 579,037; Mitten, caterpillar's A. Slomka. 578,842; Mould. See Ice cream mould; Motor. See Electric motor; Mowing and reaping machine, H. E. Olson. 578,786; Music stand, O. A. Bronson. 578,909; Musical instrument, H. E. Whelan. 578,737; Musical instrument, P. Zintzsch. 579,081; Musical instrument, stringed, C. Henlein. 578,872; Needlework fabric, J. Vialon. 578,783; Nickel from copper in ore or matte, separating, N. J. Hyblmette. 579,111; Nozzle, F. W. Adam. 578,706; Nut lock, P. E. Budlong. 578,717; Oil tanks, automatic cutoff for, G. W. Hess. 578,744; Oiling device, A. T. Ballantine. 578,961; Orange knife, A. E. Drew. 579,088; Ores, reducing, H. L. Bridgman. 578,912; Organ action, electropneumatic, Hastings & Flaherty. 578,853; Organ fan and case, M. Clark. 578,860; Oven, bake, A. Rauber. 578,833; Overshot or undershot wheel for propelling machinery, J. H. Highsmith. 578,745; Oyster tong, J. Brocton. 578,837; Package for mustard, etc., C. Gulden, Jr. 578,920; Padlock, Troast & Amwake. 578,791; Painting machine, cloth, R. E. Menzie. 579,067; Paper box, R. P. Brown. 579,105; Paper box shucks, machine for making, W. H. Wasson. 579,029; Paper holder, J. T. Hoyt. 579,092; Pen, R. W. Robinson. 578,834; Pen, fountain shading, F. Van Gerpen. 578,955; Penholder, S. M. Rhone. 578,778; Percussion wheel, F. M. F. Cazim. 578,813; Pew blow, attachment for extension of, I. H. Webb. 579,027; Photographic apparatus, aerial, W. A. Eddy. 578,880; Pianoforte or pianette, J. Strong. 578,782; Picker. See Bean picker; Picture frame, metallic, R. Liebmann. 578,936; File fabric, J. H. Brocton. 578,917; Pipe. See Tobacco pipe; Pipe coupling and fitting, long screw, Le Chard & Best. 578,933; Pipe wrench, Furbee & Barrett. 579,053; Piping for heat distribution in buildings, J. H. Mills. 579,070; Placket fastener, J. R. Rueckert. 578,946; Planing machine, L. L. Bartlett. 578,712; Planter attachment, S. W. Myers. 578,757; Planter, corn, W. T. M. Brunner. 579,106; Plow, W. Easley. 578,730; Plow, H. G. Alexander. 578,877; Pneumatic dispatch tube systems, switch rail for, C. F. Pike. 578,943; Pot. See Coffee pot; Press. See Baling press; Press, O. Smith. 579,019; Printing machine, W. Scott. 578,778; Printing machine, fabric, S. H. Sharp. 579,016; Printing machine, stencil, A. B. Dick. 578,726; Printing press, C. G. Harris. 578,739; Projective, W. H. Bell. 579,055; Propelling means for boats, R. Fryer. 578,815; Propelling vessel, J. G. Graham. 578,827; Pruning tool, reversible, D. C. Seales. 579,083; Pump, J. Stumpf. 578,950; Pump, air lift, Miller & Thompson. 579,069; Pump, rotary, F. Marburg, Jr. 578,838; Puzzle, J. C. Dando, Jr. 579,045; Rail. See Preventing derailments, safety, H. Biermann. 578,854; Railway, J. I. Newburg. 578,806; Railway crossing signal, C. Selden. 578,840; Railway crossings, arrangement for closing or opening bars at, H. Biermann. 578,823; Railway rail, H. T. Thighe & Childs. 578,897; Railway rail joint, L. W. Kennedy. 578,882; Railway rail joint, J. D. Trammell. 578,790; Railway switch, D. F. Carver. 578,965; Railway switch, Hart & Field. 578,924; Railway switch, E. Schuler. 579,011; Reaper reel rake, W. Butterfield. 578,719; Reel. See Fence wire reel; Refrigerator car ventilator screen, G. F. Brown, Jr. 579,087; Rein guard attachment for shafts, A. B. Rue. 578,901; Releasing device, animal, J. T. Lally. 579,113; Repeater, C. W. Lelser. 578,937; Rivets, thumb racks, machine for making, W. G. Allen. 578,850; Rope coiling machine, J. Garsed. 579,054; Rotary engine, J. F. McElroy. 578,759; Salt box, T. Tellefsen. 578,952; Sample holder, W. D. Smith. 578,849; Sanitary mop, M. E. Moran. 578,827; Saw filing machine, J. C. Ballew. 579,103; Sawmills, combined set works and index mechanism for, R. D. Inman. 578,928; Sawing machine, B. G. Luthar. 578,826; Scale, computing, J. H. Swihart. 578,784; Scarf pin seamer, I. H. Johannes. 578,922;

Scissors or shears, B. Wesselmann.....	578,085
Scraper, G. B. Wilder.....	578,960
Screw machine, F. Schulze.....	578,777
Seal bolt, G. S. Tiffany.....	578,786
Seal lock, W. Deely.....	578,798
Seeder, broadcast, G. W. Eltzroth.....	579,049
Separator, See Gold separator. Grease separator.	
Sewing machine attachment for making dress facing, Schorenberg & Simpson.....	579,014
Sewing machine fan attachment, P. O. Wiedemann.....	578,846
Sewing machine hemmer, Fowkes & Bennett.....	579,052
Sewing machine, tuck, W. Bowden.....	578,911
Shaft, flexible, G. H. Coates.....	578,724
Shears. See Grape shears.	
Sheet metal tube, E. A. Wilmot.....	578,799
Shuttle, self threading, J. B. Daudelin.....	579,046
Signal. See Railway crossing signal.	
Skins into horny material, conversion of, C. Marter.....	579,000
Skirt, cycling, L. L. Hirsch.....	579,061
Smelting furnace, C. Bishop.....	578,933
Spectacle frame, A. S. Stephens.....	579,069
Spindle and bearing, L. J. Murray.....	579,118
Spindle thread holder, O. C. Burr.....	578,810
Spinning machine flier, E. C. Bradley.....	578,856
Spool, jack, Dingman & Klingin.....	578,977
Spraying machine and plunger therefor, A. H. Rugges.....	578,902
Spring. See Buggy spring. Door spring.	
Sprinkling rose, H. Schaffstaet.....	578,948
Square, folding, E. G. Stoy.....	579,023
Stand. See Music stand.	
Steam boiler, J. J. Hogan.....	578,747
Steam boiler, Barling, Kilian.....	578,753
Steam trap, Hermansdorp & Blandy.....	578,873
Steering apparatus, J. Johannsen.....	578,879
Stereotype making machine, Curtis & Titsworth.....	579,044
Stirrer, barrel, L. C. Strong.....	579,025
Stirrup, G. G. Mann.....	578,956
Stocking oxidizing apparatus, O. Duckworth.....	578,906
Stopper. See Bottle stopper. Can stopper.	
Storage battery, C. T. Barrett.....	578,710
Stovepipe thimble, P. J. Haas.....	578,737
Sugar, apparatus for separating liquid from crystalline, J. W. Smales.....	579,098
Switch. See Railway switch.	
Switch operating device, W. A. Clapp.....	578,968
Sirup, apparatus for reclaiming crystallized, E. D. Smythe.....	579,021
Sirup drawing device, E. S. Palmbla.....	579,006
Tank. See Flushing tank.	
Telephone switchboard plug, F. E. Bossong.....	579,036
Telephone transmitter, W. J. Moore.....	579,003
Telephones, cutout and agitator for dust transmitters for, S. B. Rawson.....	578,771
Teletype, multiplex, S. W. Holman.....	578,992
Temperature controlling apparatus, S. Green.....	578,984
Thill support, M. J. D. Rice.....	578,774
Thread cutter, G. E. Witherell.....	578,802
Thrashing machine band cutter and feeder, G. F. Weiss.....	578,795
Thrashing machine spreader and regulator combined, Nunamaker & Williams.....	578,898
Toaster, Fergies.....	579,050
Tobacco feeding and dressing mechanism, J. F. Hartigan.....	578,740
Tobacco pipe, J. Townsend.....	578,788
Tobacco pipes, draught appliance for, F. J. Kaldenberg.....	578,881
Toilet appliance, M. Rhine.....	579,130
Tool holder, C. W. Justus.....	579,064
Toy, J. E. H. Hyde.....	578,749
Toy savings bank, C. G. Glover.....	579,058
Trace carrier, Cotham & Wells.....	578,971
Traction engine, A. J. Martin.....	578,888
Traction wheel, J. A. Justice.....	578,932
Trap. See Animal trap. Sanitary trap. Steam trap.	
Tree extractor and carrier, J. A. Rutherford.....	578,836
Tricycle or bicycle, N. Merrill.....	579,002
Tripod, A. H. Loebis.....	578,998
Trolley repair, W. B. Woods.....	578,848
Truck, car, E. Cliff.....	578,814
Trucks, system of motor, J. F. McElroy.....	578,760
Tube. See Sheet metal tube.	
Tube cleaner, H. F. Hall.....	578,922
Tubes, apparatus or machinery for closing and securing metal, Platz & Huizer.....	578,945
Tubes with viscid or semifluid material, apparatus for filling, Platz & Huizer.....	578,944
Tubing, device for connecting flexible, J. B. Green.....	578,983
Twister, thread, C. C. E. Van Alstine.....	578,792
Type holder, J. L. McMillan.....	578,829
Typesetting machine, J. B. Bell.....	578,713
Typewriting machine for the blind, A. Swindler.....	578,785
Typewriting machine type bar, H. McDougall.....	578,894
Valve, J. Platt.....	578,831
Valve, gate, H. N. Libbey.....	579,114
Valve mechanism, H. K. Justice.....	578,903
Valve operating mechanism for sirup jars, J. Ormerod.....	578,767
Valve, steam or water throttle, C. J. Gustafson.....	578,736
Vending machine, coin controlled, A. Jussem.....	578,994
Violin mute, J. E. Naudain.....	578,895
Vise, W. E. Steiner.....	579,022
Wagon brake, automatic, H. M. Flanagan.....	579,109
Wagon dump bed, Lorash & Hilgemier.....	579,116
Water indicator and alarm, Cooley & Logee.....	578,725
Watertight hinged joint for bear trap dams, etc., O. W. Getchell.....	578,982
Water wheel, percussive, F. M. E. Cazin.....	578,812
Waterproof article and preparing it, S. Bennett.....	578,714
Wheel. See Gear wheel. Percussion wheel. Water wheel.	
Whip socket, A. T. Iron.....	578,929
Window, J. O. L. McMillan.....	578,940
Window cleaning device, Ezekiel & Stone.....	579,108
Wire, etc., apparatus for treating, Hayes & Jernberg.....	578,819
Wood preserving compound, R. L. Valleen.....	579,101
Woven fabric, A. Heald.....	578,742
Wrencher, E. L. Kimbark.....	578,883
Wrench. See Pipe wrench.	

DESIGNS.

Belt, L. Sanders.....	26,756
Bicycle fork crown, C. H. Metz.....	26,764
Bicycle rack, H. A. Dolge.....	26,765
Button, campaign, G. Ashby.....	26,755
Button setting, W. B. P. Dowse.....	26,767
Carpet, A. Danby.....	26,782
Dress shield, I. B. Kleinert.....	26,757
Fork, corn, M. J. Donnelly.....	26,772
Indicator casing, J. C. Hirsch.....	26,772
Lamp, bicycle, Havell & Williams.....	26,763
Mowing machine section knife, W. M. Brinkerhoff.....	26,778
Photographic mount, J. W. McCabe.....	26,760
Plate or similar article, A. Legner.....	26,761
Pole holder, G. S. Webber.....	26,770
Shelf key, A. S. H. Field.....	26,771
Strainer, well, A. D. Cook.....	26,775
Tile, hollow, H. A. Maurer.....	26,759
Tool handle, J. A. Traut.....	26,768
Water wheel, hurdy-gurdy, F. M. Bookwalter.....	26,774
Windmill tower anchor, O. J. Ziegler.....	26,775
Woven fabric, H. W. Smith.....	26,780
Wrench, R. B. Shafer.....	26,766
Writing shield, T. H. Burchell.....	26,758

TRADE MARKS.

Apertent waters and medicinal preparations containing salts, salts of, E. Saxlehner.....	29,700
Baking powder, M. Kahn.....	29,697
Fire extinguishing apparatus, Dupulet D'Arnoul.....	29,710
Liniments or ointments, J. V. Crum.....	29,705
Linseed meal, Cleveland Linseed Oil Company.....	29,698
Pens for vertical writing, Spencerian Pen Company.....	29,696
Remedies, poultry, pigeon, pet stock and veterinary, Imperial Remedy Company.....	29,703
Salve, J. MacRae.....	29,706
Skates, ice, Union Hardware Company.....	29,711
Stove castings, Detroit Stove Works.....	29,707
Stoves, fluid or oil, Novelty Manufacturing Company.....	29,709
Stoves, heating and cooking, Detroit Stove Works.....	29,708
Tonics, Brown Manufacturing Company.....	29,701
Veterinary remedies, C. H. Lanyon.....	29,704
Whisky, J. Blank & Company.....	29,699

A printed copy of the specification and drawing of any patent in the foregoing list, or any patent in print issued since 1863, will be furnished from this office for 10 cents. In ordering please state the name and number of the patent desired, and remit to Munn & Co., 361 Broadway, New York. Special rates will be given where a large number of copies are desired at one time.

Canadian patents may now be obtained by the inventors of the inventions named in the foregoing list, provided they are simple, at a cost of \$40 each. If complicated the cost will be a little more. For full instructions address Munn & Co., 361 Broadway, New York. Other foreign patents may also be obtained.

Advertisements.

ORDINARY RATES.

Inside Page, each insertion -- 75 cents a line
Back Page, each insertion --- \$1.00 a line
For some classes of Advertisements, Special and Higher rates are required.

The above are charges per agate line—about eight words per line. This notice shows the width of the line, and is set in agate type. Engravings may head advertisements at the same rate per agate line, by measurement, as the letter press. Advertisements must be received at Publication Office as early as Thursday morning to appear in the following week's issue.

Star Foot power
Screw...
...cutting
Lathes Automatic
Cross feed
9 and 11-inch Swing.
New and Original Features
Send for Catalogue B.
Seneca Falls Mfg. Company,
695 Water St., Seneca Falls, N. Y.

POWER & FOOT LATHES SHAPERS, PLANERS, DRILLS
MACHINE, SHLOUT FITS, TOOLS
AND SUPPLIES. CATALOGUE FREE
SEBASTIAN LATHE CO. 120 CULVERT ST. CINCINNATI, O.

ROCK DRILLS
AIR COMPRESSORS
SIMPLEST, MOST EFFICIENT and DURABLE.
RAND DRILL CO.
Send for Catalogue. 100 Broadway, New York.

Water Emery
Tool Grinder
Has no pumps, no valves. No piping required to supply it with water. Always ready for use. Simplest in construction, most efficient in operation.
Send for catalogue and prices—
W. F. & JNO. BARNES CO.
1999 Ruby St., Rockford, Ill.

A Book of Tools

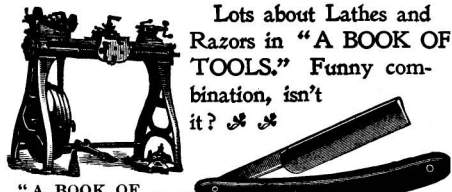

Lots about Lathes and Razors in "A BOOK OF TOOLS." Funny combination, isn't it?

"A BOOK OF TOOLS" is the most complete Catalogue ever issued; contains 556 pages, over 2,000 illustrations, prices are given.
A copy of this book sent, postpaid, to any address upon receipt of 25 cents in stamps.
CHAS. A. STRELINGER & CO.
Address Box 12½, Adv. Dept. DETROIT, MICH.

STEAM STAMP MILL
A mill for crushing ores. Equal in efficiency to a five stamp battery, and at a fraction of the expense.
A boon alike to the prospector and mining capitalist. Send for catalogue.
GATES IRON WORKS, Dept. C.
650 Eiston Ave., Chicago, U. S. A.

AMERICAN PATENTS.—AN INTERESTING and valuable table showing the number of patents granted for the various subjects upon which petitions have been filed from the beginning down to December 31, 1894. Contained in SCIENTIFIC AMERICAN SUPPLEMENT, No. 1402. Price 10 cents. To be had at this office and from all newsdealers.

DROP FORGINGS
WYMAN & GORDON
WORCESTER, MASS.
28 BRADLEY STREET.

Agents Wanted!

The enormous demand for the Berliner Gramophone in every nook and corner of the United States has made it necessary for us to call the attention of the Scientific American readers to the fact that we want responsible wide-awake agents to represent us and sell our goods. Correspondence solicited.

NATIONAL GRAMOPHONE CO.,

894 Broadway, New York City.

HIGH SPEED INDICATOR
May be run at highest speed required without heating. Reads either right or left. 0 mark may be instantly moved to starting point. Working parts incased.
Price \$1.00
New rubber tips.
THE STARRETT CO. Box 13, Athol, U. S. A.

STARK No. 3
Bench Lathe
With Grinder and Attachment
Send for catalog B.L.
JOHN STARK
WALTHAM, MASS.
Turk Bros., West Randolph Street, Chicago, Ill. Chas. Churchill & Co., Ltd., 21 Cross Street, Finsbury, London E. C., England.

ELECTRO-CHEMISTRY, RECENT ADVANCES in.—By J. W. Richards, A.C., Ph.D. A very exhaustive and interesting paper on the progress that has recently been made in the apparatus for and methods of prosecuting work in the domain of electro-chemistry. Contained in SCIENTIFIC AMERICAN SUPPLEMENT, Nos. 1014 and 1015. Price 10 cents each. To be had at this office and from all newsdealers.

C. & F. Drill Holder
Attachment converting a Breast or Hand Drill into a Bench Drill. Readily clamped to table and holds almost any size or pattern of drill stock. Price \$1.50.
Send stamp for catalogue of machinists' tools.
CHANDLER & FARQUHAR,
38 Federal Street, BOSTON, MASS.

Queen's Patent "Triple Plate" Toepler-Holtz Electrical Machine.
Can be used at all times of year and in all kinds of weather. Prices range from \$25 to \$50. Send circular on application.
We carry a complete line of Electrical and Physical Instruments and Apparatus.
QUEEN & CO., Inc.
1011 Chestnut St. Philadelphia, Pa.

Experimental & Model Work

Circulars & advice free. Gardam & Son, 96 John St., N. Y.

EDGE TOOLS
are often nearly ruined by using a grindstone not adapted to the work. Our quarries produce a large variety of grits suitable for grinding any tool.
May we send you our Catalogue, which will give you some information?
GRAFTON STONE COMPANY,
No. 80 River Street, Grafton, Ohio.

Cool News!
Everything you want to know about every Tool you can think of. Our new 1897 Tool Catalogue is a veritable Tool Encyclopedia. A complete Tool List for Metal Workers and Mechanics of all kinds. Mention this paper and send us 35c, and we will mail you, postpaid, a copy of this 710-page book with discount sheet.
Montgomery & Co.
MAKERS AND JOBBERS IN FINE TOOLS
105 FULTON STREET, NEW YORK CITY.

CIVIL ENGINEERING
In all Branches; Mechanics; Architecture; Electricity; Mining; Plumbing; Mechanical and Architectural Drawing; Steam Engineering (Stat'y., Loco. and Marine).
The International Correspondence Schools
TAUGHT BY MAIL
MORROUHOUGH PRACTICAL
Surveys, Draughtsmen, Steam Engineers, Electrical Workers, Machinists, Carpenters Plumbers, Steam Fitters, Miners. References Everywhere. Free Circular. State Subject you wish to Study.
B. 942, Scranton, Pa.

COILS AND BENDS
— of —
Iron, Brass and Copper Pipe
ALL STYLES.
The NATIONAL PIPE BENDING CO.
152 River St., New Haven, Conn.

THE ORNAMENTAL IRON INDUSTRY.—Description of the method of manufacturing wrought iron into ornamental and artistic forms. With 9 illustrations. Contained in SCIENTIFIC AMERICAN SUPPLEMENT, No. 1020. Price 10 cents. To be had at this office and from all newsdealers.

The Coburn Patent Trolley Track Store Ladders.
A PAIR OF STAIRS ALL ALONG THE LINE OF SHELVES.
Send for Book.
The Coburn Trolley Track Mfg. Co.
HOLYOKE, MASS.

The Long-Sought-For Found at Last
AN IMPULSE WITH EVERY TURN OF THE CRANK. The Hicks Compound Cylinder Gas and Gasoline Engine.
The Engine of the future. This engine will run steadily and reliably as the best automatic steam engine, and much better than the ordinary single cylinder. Catalogue free. Frontier Iron Works, 601 ATWATER ST., DETROIT, MICH.

This beats Wind, Steam, or Horse Power. We offer the **WEBSTER** 2½ actual horse power **GAS ENGINE** for \$1.50, less 10% discount for cash. Built on interchangeable plan. Built of best material. Made in lots of 100 therefore we can make the price. Boxed for shipment, weight 300 pounds. Made for Gas or Gasoline.
Write for Special Catalogue.
WEBSTER M'FG CO.
1074 West 15th Street, CHICAGO, ILL.

GAS and GASOLINE ENGINES.
Using Natural Gas, Coal Gas, Producer Gas, and Gasoline direct from the tank. 1 to 40 H. P., actual.
The Springfield Gas Engine Co., 21 W. Washington St., Springfield, O.

The Chicago Gas & Gasoline Engine
The simplest gas and gasoline engine on the market. Has no equal for absolute, steady speed and durability. It is a dwarf in size and a Samson in strength. Catalogue sent on application.
MANUFACTURED BY **J. J. NORMAN CO.,** 48 "A" South Clinton St., CHICAGO, ILL.

GREENFIELD Steam Engine Works.
Established 1874. Manufacturers of Greenfield Stationary, Portable and Yacht ENGINES AND BOILERS.
Also Horizontal, Automatic and Variable Cut-off Engines. Sizes from 3 to 75 Horse-Power.
Also Vertical and Horizontal and Marine Boilers, Steam Pumps and Adams' Grate Bars.
W. G. & G. GREENFIELD, East Newark, N. J.

If you want the best **CHUCKS**, buy Westcott's Little Giant Double Grip Drill Chucks, Little Giant Drill Chucks Improved, Onedra Drill Chucks, Cutting-off Chucks, Scroll Combination Lathe Chucks, Geared Combination Lathe Chucks, Plain Universal Lathe Chucks, Independent Lathe Chucks. Made by Westcott Chuck Co., Oneida, N. Y., U. S. A. Ask for catalogue in English, French, Spanish or German. First Prize at COLUMBIAN EXPOSITION, 1893.

MEWER AUTOMATIC FEED DRILL
An indispensable Labor Saver. Will feed, fine or coarse, at any angle, without pressure or loss of power. Warranted.
For particulars, prices, etc.,
MEWER TOOL CO.,
16 Elm St., Portland, Me., U. S. A.

THE MODERN ICE YACHT.—BY Geo. W. Polk. A new and valuable paper, containing full, practical directions and specifications for the construction of the fastest and best kinds of Ice Yachts of the latest, most approved forms. Illustrated with engravings drawn to scale, showing the form, position, and arrangement of all the parts. Contained in SCIENTIFIC AMERICAN SUPPLEMENT, No. 624. Price 10 cents. To be had at this office and of all newsdealers.

PERFORATED METAL
OF EVERY DESCRIPTION
FOR ALL USES
WEHARRINGTON & KING
PERFORATING CO.
225 NORTH UNION ST. AND 284 PEARL ST. NEW YORK

Crescent Bicycles

KNOWN QUALITY

You are making no experiment in buying a Crescent Bicycle. 56,000 men, women and children bought Crescents in 1895; 70,000 in 1896.

Owners of Crescents are all around you. Ask them about Crescent quality. They know how good it is.

Crescent agents will explain the many improvements for 1897. We want you to ride a Crescent this year.

WESTERN WHEEL WORKS,
Chicago New York
Catalogue free. Agents everywhere.



WE UNDERSSELL ALL!

- Bicycle Electric Lights, . . . \$4.00
- Necktie Electric Lights, . . . 1.50
- Edison Electric Motors, . . . 1.00
- 88 Medical Batteries, . . . 3.95
- \$100 Bicycles, best made, . . . 39.00
- Electric Bells, finest,30
- Dry Batteries, best,25

Agents Wanted.
Our Bicycle Electric Light is the best thing that ever happened.
Catalogue 2 cts.

OHIO ELECTRIC WORKS, Cleveland, Ohio.

ZENTMAYER'S • MICROSCOPES

In use by the leading Professors and Colleges throughout the world. The acme of perfection in the art of Microscope making. Heartily indorsed wherever used.

Complete illustrated catalogue of microscopes and optical apparatus sent free. Micrometer Rulings in English and Metric scales.

J. ZENTMAYER,
211 South Eleventh St. Phila., Pa.

MANUFACTURE OF BICYCLES.—A very comprehensive article giving the details of construction of every part of these vehicles. With 15 engravings. Contained in **SCIENTIFIC AMERICAN SUPPLEMENT, No. 908.** Price 10 cents. To be had at this office and from all newsdealers.

"BUILT LIKE A WATCH"

THE MOST CAREFUL EXAMINATION FINDS NO DEFECTS IN THE

Sterling

SEND FOR HANDSOME ILLUSTRATED CATALOGUE.
Sterling Cycle Works
274-278 Wabash Av. Chicago.
AGENCIES IN ALL THE PRINCIPAL CITIES.

HALF A CENTURY OF CYCLES.—AN interesting history of the cycle from its origin up to the present time. The first crank-driven bicycle. The "bone-shaker" and its successors. The triangle. The modern wheel. Cycle building a science. Points of improvement. The pneumatic tire. A hand and foot cycle. With 9 illustrations. Contained in **SCIENTIFIC AMERICAN SUPPLEMENT, No. 1012.** Price 10 cents. To be had at this office and from all newsdealers.

I PRINT MY OWN

Make money printing for others. Our \$15 Press prints a newspaper. Type setting easy, printed rules. Send stamp for catalogue, presses and supplies, to the factory.

KELSEY & CO.
Meriden, Conn.

BRASS SPECIALTIES
made from Sheet Brass, Rods or Wire.
F. E. CHESTERMAN CO., 241 Arch St., PHILA., PA.

NICKEL AND Electro-Plating Apparatus and Material.
THE **Hanson & VanWinkle Co.,**
Newark, N. J.,
136 Liberty St., N. Y.
36 & 37 S. Canal St., Chicago.

Williams' Shaving Soaps



INCOMPARABLE FOR THEIR RICH CREAM-LIKE LATHER.

NO OTHER SO SOOTHING REFRESHING. LUXURIOUS.

WILLIAMS' SOAPS—in principal forms—sold by Dealers everywhere.



Luxury Shaving Tablet
25 cents.
Round—just fits the cup. Delicate perfume.



"Genuine Yankee" Soap
10 cents.
Oldest and most famous cake of shaving soap in the world.



Williams' Shaving Soap
25 cents
(Barbers')



This is the kind your barber should use. Exquisite also for Toilet and Bath. Used in thousands of the best families. Sure cure for "chapped hands." 6 cakes in a package—40 cts. Trial sample for 2 cent stamp.

NOTE—If your dealer fails to supply you—we mail these soaps to any address—postpaid—on receipt of price.

Address **The J. B. Williams Co., Gastonbury, Ct. U.S.A.**
LONDON: 64 GREAT RUSSELL ST., N. W. SYDNEY: 101 CLARENCE ST.

TELEPHONES

For Long or Short Distance Use. Also Interior or Warehouse Telephones. Sent on trial to responsible parties. Sold thousands during the last two years, every one a success.

Send for Circular and Testimonials.

Julius Andrae & Sons Co., MILWAUKEE, WIS.

BUY TELEPHONES
That Are Good—Not "Cheap Things"

The difference in cost is little. We guarantee our apparatus and guarantee our customers against loss by patent suits. Our guarantee and instruments are **Both Good**

WESTERN TELEPHONE CONSTRUCTION CO.
250-254 South Clinton Street, Chicago

Largest Manufacturers of Telephones exclusively in the United States.

50 YEARS' EXPERIENCE.

PATENTS

TRADE MARKS, DESIGNS, COPYRIGHTS &c.

Anyone sending a sketch and description may quickly ascertain, free, whether an invention is probably patentable. Communications strictly confidential. Oldest agency for securing patents in America. We have a Washington office.

Patents taken through Munn & Co receive special notice in the

SCIENTIFIC AMERICAN,
beautifully illustrated, largest circulation of any scientific journal, weekly terms \$3.00 a year; \$1.50 six months. Specimen copies and **HAND BOOK ON PATENTS** sent free. Address

MUNN & CO.,
361 Broadway, New York.

"AS GOOD AS APOLLO"

This particular lie doesn't do any harm; it's as old as Methuselah.

Does us good; and the public too. If all the galvanized iron were said by maker and seller to be "as good as Apollo," the lie would defeat itself and advertise us.

Apollo Iron and Steel Company,
Pittsburgh, Pa.

Durable—Easily Applied.

This roofing is manufactured from natural Trinidad asphalt materials, and will not dry up and become brittle under exposure to the weather as coal-tar roofings do. Send for free sample of roof 12 years old, with circular and price list to

WARREN'S NATURAL ASPHALT READY ROOFING
WARREN CHEMICAL & MFG. CO.,
55 Fulton Street, New York, U. S. A.

ACETYLENE GAS AND CARBIDE OF Calcium.—All about the new illuminant, its qualities, chemistry, pressure of liquefaction, its probable future, experiments performed with it. A most valuable series of articles, giving in complete form the particulars of this subject. Apparatus for making the gas. Contained in **SCIENTIFIC AMERICAN SUPPLEMENT, Nos. 998, 1004, 1007, 1012, 1014, 1015, 1016, 1022, 1035 and 1038.** The most recent apparatus of simple and more elaborate type described and illustrated in special acetylene Supplement No. 1037. Price 10 cents each. To be had at this office and from all newsdealers.

MODELS & GEARS EXPERIMENTAL WORK CATALOGUES FREE UNION MODEL WORKS CHICAGO

THE NEW BRISTOL COUNTER

Registers an accurate account of work done on printing presses, grain tallies, weighing, measuring and other automatic machines. Counts up to 1,000,000 and repeats automatically. Simple, accurate, durable. Special counters to order. Send for circular.

C. J. ROOT, Bristol, Conn., U. S. A.

MURRAY

Our New Catalogue for 1897 contains 260 pages of bargains. Single Buggy Harness \$3.90; Double Buggy Harness \$12.75; Road Wagons \$19.95; Top Buggies \$29.85; Road Carts \$8.90; Phaetons, Surreys, Spring Wagons, Delivery Wagons, Milk Wagons, Farm Wagons & everything on wheels at prices never before heard of. If interested, send 8c. (stamps), postage for 260-page catalogue No. 2.

WE SELL DIRECT TO THE CONSUMER
WILBER H. MURRAY MFG CO.
CINCINNATI, OHIO, U.S.A.

PRICE \$19.50 MURRAY ROAD CART
PRICE \$29.85 MURRAY TOP BUGGY
PRICE \$54.90 MURRAY PHAETON
PRICE \$3.90 MURRAY HARNESS

The Waverley Bicycle

\$100 \$60

The Waverley Bicycle for 1897 is the acme of bicycle construction. New and expensive principles of construction involved make the cost of building enormous. Hence the price is \$100.

The only bicycle with true bearings

Last year the Waverley was as good as any wheel in the market—better than most. Because new machinery was not needed for its continued construction, the price of the improved 1896 model has been reduced to \$60—a saving of \$25 to you. Catalogue Free.

Indiana Bicycle Co., Indianapolis, Ind.

LOCK UP YOUR WHEEL!

Keep your Bicycle safe from strangers by using

THE COMBINATION LOCK

12 combinations. 3/4 oz. weight. Price 25 cents. Illustrated catalog of Bicycle Sundries free to dealers only.

GEO. W. NORR,
148 N. Fourth St. Philadelphia, Pa.

CROOKES TUBES AND ROENTGEN'S Photography.—The new photography as performed by the use of Crookes tubes as a source of excitation. All about Crookes tubes. **SCIENTIFIC AMERICAN SUPPLEMENT, Nos. 181, 189, 238, 243, 244, 792, 795, 905, 980, 1050, 1054, 1055, 1056, 1057,** also **SCIENTIFIC AMERICAN, Nos. 7, 8, 10 and 14,** vol. 74. These profusely illustrated SUPPLEMENTS contain a most exhaustive series of articles on Crookes tubes and the experiments performed with them. Among them will be found Prof. Crookes' early lectures, detailing very fully the experiments which so excited the world, and which are now again exciting attention in connection with Roentgen's photography. Price 10 cents each. To be had at this office and from all newsdealers.

CROOKES TUBES X-RAY APPARATUS

Send for Catalogue A.

Ruhmkorff Coils, Static Machines, Fluoroscopes, etc. PHOTOGRAPHIC SUPPLIES.

SWETT & LEWIS CO., Successors to G. A. Frei & Co., 11 Bromfield St., Boston.

BUGGIES, Carts, Surries, Phaetons, Spring Wagons, Harness and Saddles shipped C. O. D. anywhere to anyone with privilege to examine at lowest wholesale prices. Guaranteed as represented or money refunded. Send for illustrated catalog and testimonials Free. Adr. (in full)

CASH BUYERS' UNION, 158 W. Van Buren St., B-131, CHICAGO

Headquarters for DUMPING HORSE CARTS.

Wide and narrow tires. Low rates of freight from our works—Tatamy, Pa.—to all points.

HOBSON & CO.
No. 4 Stone St., New York.

ESTABLISHED 1850. THE DEFIANCE MACHINE WORKS

MANUFACTURERS OF SPECIAL WOOD WORKING MACHINERY FOR HUB, SPOKE, WHEEL, BENDING, WAGON, CARRIAGE, SHAFT, POLE, NECK, YOKE, SINGLE TREE, HANDLE & BARREL-HOOP FACTORIES.

LARGEST LINE IN THE WORLD SATISFACTION GUARANTEED.

Japanese Patents Trade Marks.

PRESIDENT MCKINLEY, on March 9, issued a proclamation promulgating the treaty recently ratified between the governments of Japan and the United States providing for the reciprocal protection of Patents, Trade Marks and Designs in those countries.

Citizens of the United States may now obtain patents in Japan. Japan has been very active in adopting American and European inventions; and as patents heretofore have been granted only for inventions made by native Japanese, the foreign inventor could not obtain protection, foreign inventions becoming public property as soon as publication had taken place. Foreigners may now obtain Japanese patents, provided the application is filed before the invention becomes publicly known or used in Japan. The population of Japan is estimated at about forty-five millions. For further particulars, cost, etc., apply to

Messrs. MUNN & COMPANY,
361 Broadway, New York City.

STUDY AT HOME

BY OUR EFFICIENT CORRESPONDENCE METHOD,
ELECTRICITY, MECHANICAL DRAWING, MECHANICS, OR STEAM ENGINEERING.
 INSTITUTE FOR HOME STUDY OF ENGINEERING,
 46-47 Blackstone Building, CLEVELAND, OHIO

The Inland Printer
 Presents the latest improvements in each department of newspaper, book and job printing, together with a full complement of the latest trade news. Each number is an **Édition de Luxe**
 The best artistic talent has been secured to illustrate and ornament its pages. A new cover design each month by Leyendecker. Paper, composition and presswork sumptuous, and representing the highest state of the art. Price, only \$2.00 per year, 20 cents per number.

\$90 FOR
A 3 H. P. MOTOR
A 35 Light Dynamo
or Plating Dynamo
 good for 1000 Gal. solutions. Sold on payments. Write us for any size machines you want.
HOBART ELECTRIC MFG. CO., Troy, Ohio

PORTABLE SINGLE RAIL SURFACE
 Railway.—Details of construction and description of rolling stock of a new system of portable railway which may be laid upon ground that has received no special preparation for its reception. With 19 illustrations. Contained in **SCIENTIFIC AMERICAN SUPPLEMENT, No. 1014**. Price 10 cents. To be had at this office and from all newsdealers.

AGENTS WANTED
 to sell the new Patent Combination Cooking and Preserving Kettle, Food Cooker, Steamer (like cut) and Cullender in which all kinds of food can be cooked, steamed and strained. No burning or wasting of food. Scalded hands absolutely prevented. Manufactured of steel and best enamel, and warranted in every respect. Samples free and territory secured. Address
A. W. OBERMANN, 24 Bond Street, New York.

EXTEND YOUR TRADE
 MANUFACTURERS wishing to extend their trade in England should write **V. H. HOUGHTON & CO., 95 REGENT STREET, LONDON**. This firm has special facilities for doing business with English merchants and shippers, and is prepared to extend trade or open a market on moderate terms.

ELECTRIC HOSE
 IF YOU ARE WILLING TO PAY A FAIR PRICE FOR HOSE THAT IS WORTH A DOLLAR PER FOOT WHEN COMPARED WITH ANY OTHER, SEND FOR SAMPLE. **PERFECTION LAWN SPRINKLER** BY MAIL \$1.00—AS GOOD AS THE BEST.
KING & KNIGHT
 31 WENDELL ST. BOSTON, MASS.

Perfect Newspaper File.
 Subscribers to the **SCIENTIFIC AMERICAN** and **SCIENTIFIC AMERICAN SUPPLEMENT**, who wish to preserve their papers for binding, may obtain the Koch Patent File at the office of this paper. Heavy board sides, inscription "Scientific American" and "Scientific American Supplement" in gilt. Price \$1.50, by mail, or \$1.25 at this office. Address
MUNN & CO., 361 BROADWAY, NEW YORK

Sharpen It Yourself!
 If your Lawn Mower is out of order you'll find it easy to put a new edge on the blades and make it as good as new if you have a **HOME LAWN MOWER SHARPENER**. Will last 10 years with careful use. The tool is easy to operate, and guaranteed to give satisfaction. Agents Wanted.
HOME LAWN MOWER SHARPENER CO., 259 CANAL STREET, GRAND RAPIDS, MICH.

COMPLETE ELECTRIC RAILWAY \$3.00
 CAR, TRACK AND BATTERY SENT ON RECEIPT OF PRICE \$3.00 AND FINCH.
CINCINNATI, O.

ROTARY ENGINES.
 The various efforts that have been made by inventors during several generations to overcome the defects of this form of motor will be discussed in a series of articles now being published in the

Scientific American Supplement,
 beginning with the issue of April 3d, and extending over a period of three weeks. These articles give the history and development of the Rotary Engine from the year 1588 to the present day. The engravings which accompany the article have been prepared from works on the subject of Rotary Engines and from patent drawings of recent inventions, many of them showing devices of the greatest ingenuity and interest. Copies 10 cents each.
 See editorial by Prof. Thurston on another page of this issue.
MUNN & CO., Publishers, 361 Broadway, New York City.
 SUPPLEMENT, \$5.00 a year. Combined rates, with **SCIENTIFIC AMERICAN** \$4.
HYPNOTISM Sixty ways, \$5; my method, \$2. 100 page book, 10c. Occult Forces, 30c. Prof. Anderson, S. A. 47, Masonic Temple, Chicago

ONLY PORTABLE ELECTRIC PROPELLER
 MORE USEFUL ON WATER THAN BICYCLE ON LAND. REQUIRES NO SKILL OR STRENGTH. LEAVES HANDS FREE TO FISH OR SHOOT. ANY ONE CAN ATTACH TO ANY SKIFF CANOE OR ROWBOAT.
 \$150.00
 CAN GO FORWARD, BACK STOP AND STEER. WILL RUN ITSELF.
 SEND STAMP FOR ILLUSTRATED CIRCULAR.
FRANK S. ALLEN, Mfg. 136 LIBERTY ST. NEW YORK, U.S.A.

Are You Fond of Rowing?
 The pleasure of boating can be wonderfully increased by fitting your boat with
BALL-BEARING ROWLOCKS
 They can be easily fitted to any boat, are beautifully finished either in polished brass or nickel plate, wearing parts are made of case-hardened steel, three point ball bearing and are guaranteed to last a lifetime. To introduce I will deliver them to any point for \$4 per pair.
F. R. EDWARDS, Box 308, Buffalo, N. Y.

ONLY PRACTICAL MAGAZINE CAMERA.
SUNART'S "VENI, VIDI VICI,"
 SUNART MAGAZINE, SUNART FOLDINGS
 Send for Illustrated Catalogue—2 cent stamp.
SUNART PHOTO CO., ROCHESTER, N. Y.

Drying Machines
 for Grain, Sand, Clays, Fertilizers, Phosphates, Green Coffee, Wet Feeds, Salt, Sugar, Chemicals, etc. 15 Years in operation. Send for 8th illustrated catalogue.
S. E. WORRELL, Hannibal, Mo.

THE CARBIDES AND ACETYLENE
 Commercially Considered.—By T. L. Willson and J. J. Suckert, Ph.D. A consideration of the carbides and acetylene from a commercial point of view, preceded by a brief history of these compounds, the methods of their formation, and their chemical and physical properties. With 10 illustrations. Contained in **SCIENTIFIC AMERICAN SUPPLEMENT, Nos. 1015 and 1016**. Price 10 cents each. To be had at this office and from all newsdealers.

The Berkefeld House Filter.
 The only Filter Removing Typhoid and Cholera Bacilli. Tested and indorsed by many leading authorities in Europe and America. It gives a continuous flow of filtered water, absolutely free from germs. It is easily cleaned, as all impurities remain on the surface of the filtering cylinder. Cylinders can be sterilized by boiling in water for one hour. Send for circulars and prices to the
BERKEFELD FILTER CO., 4 Cedar Street, New York.

Chain BELTING of Various Styles, ELEVATORS, CONVEYORS, COAL MINING and HANDLING MACHINERY.
The JEFFREY MANUFACTURING CO., COLUMBUS, O.
 Send for late Catalogue "C." Branches: CHICAGO—NEW YORK.

Family Ice Machine Ice, etc., in a few minutes, \$10 and up. Filters, \$1.25 and up. Cookers, \$1. Seltzateurs to prepare one's self soda water, \$4.50 and up. L. DERMIGNY, 126 W. 25th St., N. Y.

DO YOU USE GRINDSTONES?
 If so, we can supply you. All sizes mounted and unmounted, always kept in stock. Remember, we make a specialty of selecting stones for all special purposes. Ask for catalogue.
The CLEVELAND STONE CO., 2d Floor, Wilshire, Cleveland, O.

ELECTRICAL SUPPLIES
 at Manufacturers' Prices. "Pole" Indicator, instrument to find positive and negative side of current. Guaranteed. Send for one. Price \$1.00 postpaid.
CLYMER & HEILMAN, Reading, Pa.

WATER MOTORS
GAS ENGINES & VENTILATING FANS
 The best Motor in the world for driving all kinds of light machinery, noiseless, neat, compact; invaluable for blowing church organs, running printing presses, coffee mills ventilating fans, ice cream freezers, meat choppers, etc. In use the world over, and recommended by water companies everywhere. Address for circular, **Hackus Water Motor Co., Newark, N. J., U.S.A.**

MAKE ICE CREAM
 in 30 seconds. Best purest, cheapest. From milk or cream. Saves ice and salt. Made easily with **Polar Star Instant Freezer**. Rapid, clean, economical. Always in order. Freezes with snow hard dry and smooth. IF DON'T SCRAPS TIN. Live agents wanted everywhere.
Polar Star Mfg. Co., 231 Levant St., Phila., Pa.

ICE-BOATS—THEIR CONSTRUCTION
 and Management. With working drawings, details, and directions in full. Four engravings, showing mode of construction. Views of the two fastest ice-sailing boats used on the Hudson river in winter. By H. A. Horsfall, M.E. Contained in **SCIENTIFIC AMERICAN SUPPLEMENT, 1**. The same number also contains the rules and regulations for the formation of ice-boat clubs, the sailing and management of ice-boats. Price 10 cents.

Portable Striking Bag.
 A Home Gymnasium. Stand in corner when not using. Agents Wanted. Send for Illustrated Catalogue.
Hawthorne & Shoble, 600 Chestnut St., Philada., Pa.

ACCIDENTS WILL HAPPEN
 in spite of every precaution, and when not attended by loss of life, they often result in the loss of a limb. But science, nowadays, can do much to restore an arm or leg or both. Artificial limbs with **MARKS' PATENT RUBBER HANDS AND FEET** enable a man to look as well and work as well as ever. They are comfortable and convenient and last for years without needing repairs. Over 18,000 in use all over the world. Maker of the United States and other Governments. Send for illustrated book of 544 pages, free.
A. A. MARKS, 701 Broadway, New York City.

HELP WANTED UNCLE SAM
 wants bright men to fill positions under the Government. More than 2000 appointments will be made in the Postal Service, for which examinations will be held in June and August in all cities. Particulars about all examinations (Customs, Internal Revenue, Railway Mail, Departmental, etc.), salaries, dates and places free if you mention **Scientific American**. **NATIONAL CORRESPONDENCE INSTITUTE, 2d National Bank Building, Washington, D. C.**

INFORMATION WANTED regarding a machine to wrap cakes of soap. Address C. R. S., Box 773, New York

Mechanical Draughtsman wants position. 10 years in drawing room, 2 years' shop practice. References. Address H., Box 773, New York.

Shorthand by Mail Thoroughly taught by re-lesson free. Potts Shorthand College, Williamsport, Pa.

MAGIC LANTERNS WANTED AND FOR SALE
HARBACH & CO., 809 Filbert St. Phila., Pa.

ICE MACHINES, Cortis Engines, Brewers, and Bottlers' Machinery. THE VILTER MFG. CO., 899 Clinton Street, Milwaukee, Wis.

\$5000 We offer cash for simple ideas, patented or not. Send 10 cents to cover postage and expense, and we will send plan and particulars.
H. H. FRANKLIN MFG. CO., Syracuse, N. Y.

EXPERIMENTAL MACHINE & MODEL
 Work. First-class equipment. Secrecy guaranteed.
H. ROBINSON & CO., 516 Southern Boulevard, N.Y. City

NOVELTY SIGNS Agents wanted to sell ready made **NOVELTY SIGNS**, 150 per cent profit. Great sellers. Catalogue free. Samples 10c. Val. Schreier, Mfr., Milwaukee, Wis.

WILLSON CARBIDE WORKS Calcium carbide. Samples of 200 lbs. \$15 f. o. b. New York, including iron case packages. Patentees and manufacturers for export. Office 20 Maiden Lane, New York.

STEEL STAMPS FOR MARKING TOOLS & C
FIGURE & ALPHABET SETS AT LOWEST PRICES.
SCHWAAB STAMP & SEAL CO., MILWAUKEE, WIS.

Charles E. Schmunk, Glassurgical Engineer. Expert opinion given on anything appertaining to Glass or Glass Ware. 20 years' practical experience. Drawings made for Machinery for Glass Ware. 237 First Ave., Pittsburg, Pa. Expressage must be prepaid on models and samples. Designer of Glass Ware.

WANTED—Resident Manager for a Company working extensive mineral deposits about five hundred miles from New York. A knowledge of Mining, Hydraulic, Mechanical and Electrical Engineering requisite. Address by letter only, giving experience and reference, Room 1003, 309 Broadway, New York.

MANUFACTURE OF STARCH FROM
 Maize.—By J. Krieger. Full details of the process. With one illustration. Contained in **SCIENTIFIC AMERICAN SUPPLEMENT, No. 1012**. Price 10 cents. To be had at this office and from all newsdealers.

INVENTORS
 OF SPORTING SPECIALTIES WILL FIND IT OF ADVANTAGE TO CORRESPOND WITH AND SUBMIT THEIR ARTICLES TO H. P. O. BOX 2508 NEW YORK

Experimental Science
 By GEO. M. HOPKINS.
 17th Edition Revised and Enlarged.

Experimental Science
 840 pages, 782 fine cuts, substantially and beautifully bound. Price in cloth, by mail, \$4. Half morocco, \$5.
 This splendid work is up to the times. It gives young and old something worthy of thought. It has influenced thousands of men in the choice of a career. It will give anyone, young or old, information that will enable him to comprehend the great improvements of the day. It furnishes suggestions for hours of instructive recreation.
 Send for illustrated circular and complete table of contents. . . .
MUNN & CO., Publishers, Office of the . . . SCIENTIFIC AMERICAN, 361 BROADWAY, - NEW YORK.

Advertisements.

ORDINARY RATES.

Inside Page, each insertion -- 75 cents a line
Back Page, each insertion ---- \$1.00 a line
For some classes of Advertisements, Special and Higher rates are required.

The above are charges per agate line—about eight words per line. This notice shows the width of the line, and is set in agate type. Engravings may head advertisements at the same rate per agate line, by measurement, as the letter press. Advertisements must be received at Publication Office as early as Thursday morning to appear in the following week's issue.

Tribune & Bicycle
Tested and True.

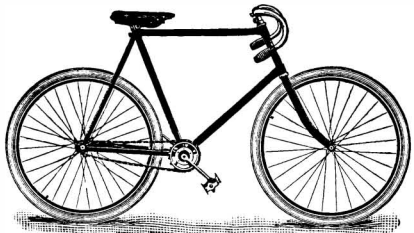

The Easiest Running Wheel in the World.

Send for Catalogue.

THE BLACK MFG. CO., ERIE, PA.

Nickel Silver Watches

We are casing all sizes of movements in this new metal. It takes a better finish and is more enduring than sterling.

It supersedes the old nickel plate, and enables one to have a perfect timepiece at small cost.

Our Solid Gold and Filled Cases, as well as Sterling Silver and Enameled patterns, are in greater variety this season than ever.

New specialties have been added.

Our '97 Model

Trump Cyclometer,

the 10,000 mile wheel recorder, are all shown in our new catalogues, which will be sent to all.

The Waterbury Watch Co.

WATERBURY, CONN.

H. P. GASOLINE ENGINES
H. B. Maxwell, 420 W. Court St., Rome, N.Y. \$100

HEIMET OIL LUBRICATES ANYTHING.
IF YOU HAVE A HOT BOX TRY IT. C. H. BESLEY & CO. CHICAGO, ILL. U.S.A.

THE CHARTER GASOLINE ENGINE

is used for almost every purpose power is applied to under the sun, and is unequalled.

Full particulars by addressing
CHARTER GAS ENGINE CO.
Box 148, Sterling, Ill.

The American Bell Telephone Company,

125 Milk Street,
Boston, Mass.

This Company owns Letters-Patent No. 463,569, granted to Emile Berliner November 17, 1891, for a combined Telegraph and Telephone, covering all forms of Microphone Transmitters or contact Telephones.

To Bicycle Riders

WE MAKE OUR TUBE of FIFTY CARBON STEEL

Because a Tube like this of Is just as strong as a Tube like this of



While WEIGHT FOR WEIGHT in a Bicycle our FIFTY CARBON Steel will last so long and TWENTY-FIVE CARBON Steel will last only so long

NOTE THE FULL IMPORT OF THE PARALLEL LINES.

The comparison which they graphically make indicates the result of the prolonged investigations of the most practical experts of the world.

That the tests in our own laboratory corroborate these results is merely so much to its credit; that the same is true of actual trial on the road equally proves the trial to have been made in bicycles of correct design and construction. THE FACT REMAINS.

The margin of safety is greatly increased by the use of this tube. Every bicycle manufacturer should use it; every dealer should insist on having it; every rider should demand it.

Send for Catalogue. THE POPE TUBE CO., HARTFORD, CONN.

IN A NEW DRESS
SEARCH LIGHT
FOR '97

RIGID BRACKET WILL NOT JAR OUT

ALL REFLECTING SURFACES PROTECTED

Control Knob SMOKED or TARNISHED

The rigid bracket holds the lantern so firmly that the light cannot jar out; covered by patents which will be maintained. \$5, delivered.
BRIDGEPORT BRASS CO., Bridgeport, Conn.

THE BICYCLE: ITS INFLUENCE IN Health and Disease.—By G. M. Hammond, M.D. A valuable and interesting paper in which the subject is exhaustively treated from the following standpoints: 1. The use of the cycle by persons in health. 2. The use of the cycle by persons diseased. Contained in SCIENTIFIC AMERICAN SUPPLEMENT, No. 1002. Price 10 cents. To be had at this office and from all newsdealers.

THOROUGH INSPECTIONS
AND INSURANCE AGAINST LOSS OR DAMAGE TO PROPERTY AND LOSS OF LIFE AND INJURY TO PERSONS CAUSED BY

STEAM-BOILER-EXPLOSIONS

HARTFORD STEAM BOILER INSPECTION AND INSURANCE CO. HARTFORD, CONN.

J. M. ALLEN, PRESIDENT V. B. FRANKLIN, VICE PRESIDENT
J. B. PIERCE, SECRETARY F. B. ALLEN, 2d VICE PRESIDENT

IMPERIAL BALL BEARING AXLE

A written guarantee with each set of axles.

97 PATTERN
5,000 sets in use. Indorsed by the leading carriage builders. Reduces friction 75 per cent. One horse can do the work of two. Mechanically perfect. Can be put on old or new work. Write for our Illustrated Catalogue and Testimonials, which we send free on application. Imperial Ball Bearing Axle Dept., 184-190 Lake Street, Chicago, Ill.

TUBULAR DRIVING LAMP.

IT is the only perfect one.
IT will not blow or jar out.
IT gives a clear, white light.
IT is like an engine head-light.
IT throws the light straight ahead from 200 to 300 ft.
IT burns kerosene.
Send for book (free).
R. E. DIETZ CO., 60 Laight Street, New York.
Mention this paper and get special discount.
—ESTABLISHED 1840.—

DIXON'S 691 CYCLE CHAIN GRAPHITE

saves wear of chain, prevents rust and increases ease, speed and comfort.
It will pay you to send 10 cents for sample.
JOS. DIXON CRUCIBLE CO., JERSEY CITY, N. J.

"BROOKS" SPRING SEAT POST

The Original. The Best. Thousands in use. Takes away all jolt and jar. Fits any wheel. Can use any saddle. If your dealer don't have it, will be sent on trial, C. O. D.—satisfaction guaranteed. Insist on having a "Brooks" upon your new wheel.
BROOKS SPRING SEAT POST CO.
1540 Marquette Building, Chicago.

H.W. JOHNS' ASBESTOS STEAM PACKING

Boiler Coverings, Millboard, Roofing, Building Felt, Liquid Paints, Etc.
DESCRIPTIVE PRICE LIST AND SAMPLES SENT FREE.
H. W. JOHNS MFG. CO., 87 Maiden Lane, N. Y.

Waltham Watches
are always guaranteed to be free from any defect in material or construction. The makers particularly recommend the movements engraved with either of the trade marks "RIVERSIDE" or "ROYAL." Made in various sizes for ladies and gentlemen, and for sale by all retail jewelers.

At 1/4 Price Bicycles, Watches, Guns, Buggies, Harness, Sewing Machines, Organs, Pianos, Safes, Tools. Scales of all varieties and 1000 other articles. Lists free. CHICAGO SCALE CO., Chicago, Ill.

No. 4 BULLS-EYE
\$12.00

For 4x5 Pictures.

As Simple as a Pocket Kodak.

Loads in daylight with our light-proof Film Cartridges. Fitted with achromatic lens, improved shutter and set of three stops. Handsome finish.
EASTMAN KODAK COMPANY, Rochester, N. Y.
Booklet Free.

PRIESTMAN SAFETY OIL ENGINE

"A thoroughly successful commercial Engine using a Safe Oil."—Franklin Institute
No Extra Insurance. No Steam. No Gas. No Gasoline. Reliable, Safe, Economical, and Convenient. Chosen by Nine Governments. Used for nearly every purpose.
PRIESTMAN & CO., Incorp'd., 530 Bourse Bldg., PHILADELPHIA, PA.

ACETYLENE APPARATUS.—ACETYLENE number of the SCIENTIFIC AMERICAN SUPPLEMENT, describing, with full illustrations, the most recent, simple, or home made and commercial apparatus for generating acetylene on the large and small scale. The gas as made for and used by the microscopist and student; its use in the magic lantern. The new French table lamp making its own acetylene. Contained in SCIENTIFIC AMERICAN SUPPLEMENT, No. 1057. Price 10 cents. To be had at office.

JESSOP'S STEEL THE VERY BEST FOR TOOLS, SAWS, ETC.
WM JESSOP & SONS L^{rs} 91 JOHN ST. NEW YORK

PRINTING INKS
The SCIENTIFIC AMERICAN is printed with CHAS. ENEU JOHNSON & CO.'S INK, Tenth and Lombard Sts., Philadelphia, and 47 Rose St., opp. Duane, New York

A Great Mining Triumph

Capt. J. R. DeLamar, of New York City, is one of the largest owners and workers of Gold Mines in the world. After the most careful investigation he purchased in August, 1895, two Griffin Mills, and his report is so remarkable as to demand the careful attention of every one interested in Gold Mining. We give it in his own words.

BRADLEY PULVERIZER CO. Gentlemen:—The two Griffin Mills have been in operation now for 90 days on the hardest rock, with the exception of corundum, that I have ever met during my mining life. They have taken the rock direct from the breaker, and they average about 20 tons to each machine, 40 mesh fine, without elevating or bolting. We simply put a 3/4 mesh sizer around the Griffin Mill, and the stuff comes out 40 mesh fine or over, which makes it an excellent pulp for leaching by cyanide or chlorination; therefore we have concluded to order 10 more Griffin Mills. We have tried high-speed rolls and dry stamps, and after looking into the Huntington Dry Pulverizer, the Narod Pulverizer, the Stedman Pulverizer, the Frisbie Lucop, the Cook, and various other dry pulverizers, unhesitatingly recommend your Griffin Mill to any one.
Yours truly,
J. R. DELAMAR.

HOW 10 GRIFFIN MILLS WORK.

DELAMAR'S NEVADA GOLD MINING CO., SALT LAKE CITY, UTAH, Nov. 24, 1896.
BRADLEY PULVERIZER CO. Gentlemen:—In answer to your inquiry as to what the "Griffin Mill" is doing at our DeLamar Mill, DeLamar, Nevada, we beg to state that we often run 310 tons per day with 10 of your mills in operation, and on one occasion these 10 mills produced 408 tons in one day. I have no hesitancy in stating that they will regularly produce at least 30 tons per day each on our ore, which is extremely and unusually hard.
Yours very truly,
H. A. COHEN, General Manager.

These strong letters coming from such representative men are conclusive evidence that we are right in claiming that the "Griffin Mill" will produce a larger amount of finer pulp at less cost than any other stamp or pulverizer made.

Let us send you a free copy of our illustrated pamphlet, which will tell you all about the Mill and bring to you other evidence of its great achievements.

BRADLEY PULVERIZER CO., 92 STATE ST., BOSTON, MASS.