

SCIENTIFIC AMERICAN

[Entered at the Post Office of New York, N. Y., as Second Class Matter. Copyrighted, 1889, by Munn & Co.]

A WEEKLY JOURNAL OF PRACTICAL INFORMATION, ART, SCIENCE, MECHANICS, CHEMISTRY, AND MANUFACTURES.

Vol. LXI.—No. 22.
ESTABLISHED 1845.

NEW YORK, NOVEMBER 30, 1889.

\$3.00 A YEAR.
WEEKLY.

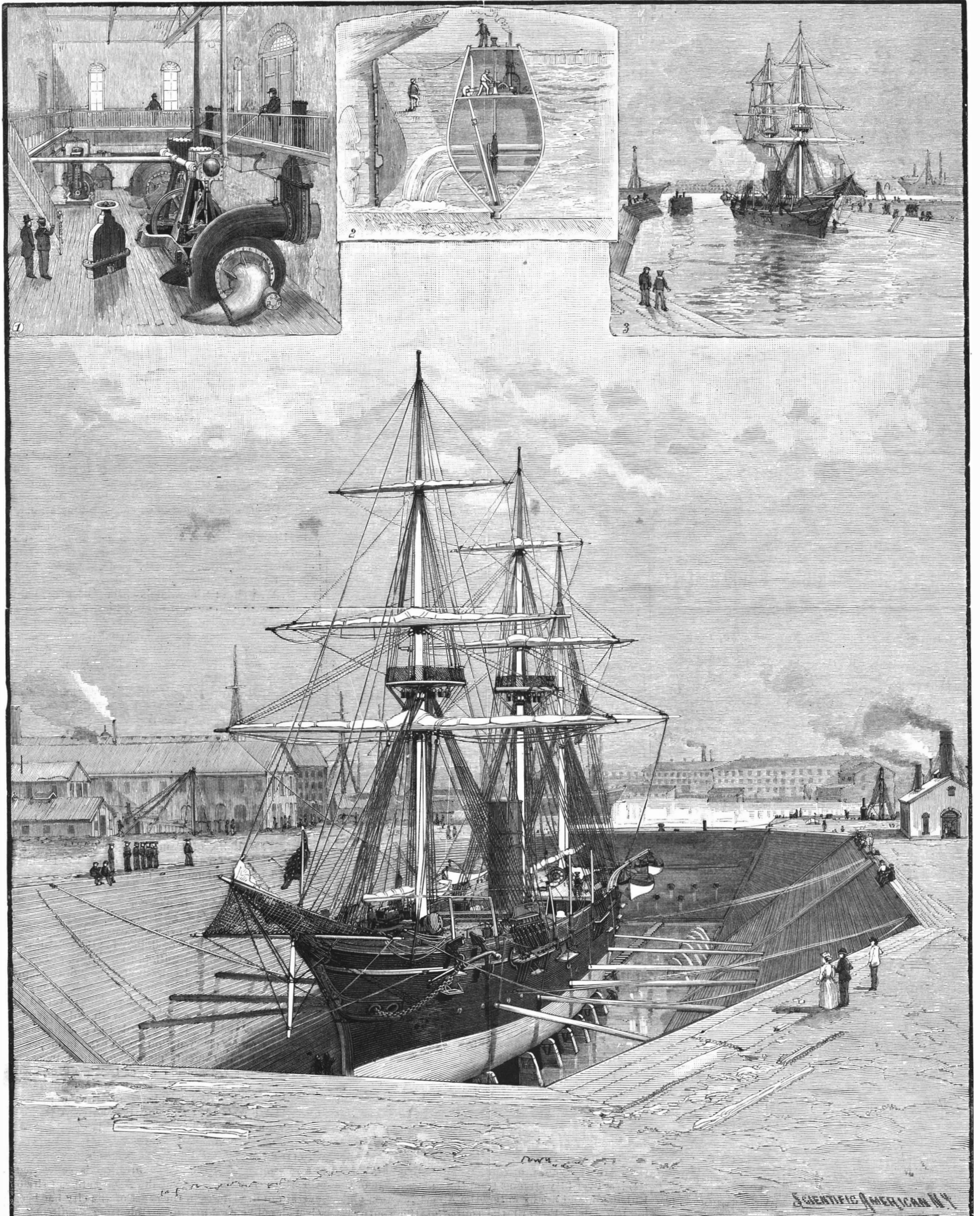

1. Engine room and pumping plant. 2. Caisson. 3. Ship entering dock.

THE NEW SIMPSON TIMBER DRY DOCK AT THE BROOKLYN, N. Y., NAVY YARD.—[See page 341.]

Scientific American.

ESTABLISHED 1845.

MUNN & CO., Editors and Proprietors.

PUBLISHED WEEKLY AT

No. 361 BROADWAY, NEW YORK.

O. D. MUNN.

A. E. BEACH.

TERMS FOR THE SCIENTIFIC AMERICAN.

One copy, one year, for the U. S. or Canada. \$3 00
One copy, six months, for the U. S. or Canada. 1 50
One copy, one year, to any foreign country belonging to Postal Union, 4 00

Australia and New Zealand.—Those who desire to receive the SCIENTIFIC AMERICAN, for a little over one year, may remit £1 in current Colonial bank notes. Address MUNN & CO., 361 Broadway, corner of Franklin Street, New York.

The Scientific American Supplement

Is a distinct paper from the SCIENTIFIC AMERICAN. THE SUPPLEMENT is issued weekly. Every number contains 16 octavo pages, uniform in size with SCIENTIFIC AMERICAN. Terms of subscription for SUPPLEMENT, \$5.00 a year, for U. S. and Canada. \$6.00 a year to foreign countries belonging to the Postal Union. Single copies, 10 cents. Sold by all newsdealers throughout the country.

Combined Rates.—The SCIENTIFIC AMERICAN and SUPPLEMENT will be sent for one year, to any address in U. S. or Canada, on receipt of seven dollars.

The safest way to remit is by draft, postal order, express money order, or registered letter.

Australia and New Zealand.—The SCIENTIFIC AMERICAN and SUPPLEMENT will be sent for a little over one year on receipt of £2 current Colonial bank notes. Address MUNN & CO., 361 Broadway, corner of Franklin Street, New York.

NEW YORK, SATURDAY, NOVEMBER 30, 1889.

Contents.

(Illustrated articles are marked with an asterisk.)

Table listing various articles such as Appliances, railway; Bicycle, military; Inventions, engineering; etc. with corresponding page numbers.

TABLE OF CONTENTS OF

SCIENTIFIC AMERICAN SUPPLEMENT

No. 726.

For the Week Ending November 30, 1889.

Price 10 cents. For sale by all newsdealers

Table listing detailed contents of the supplement, including I. AERONAUTICS, II. ARCHITECTURE, III. ELECTRICITY, etc., with page numbers.

THE UNITED STATES OF BRAZIL.

The 14th day of November, 1889, is likely to be a memorable day in the history of Brazil, for it was then the monarchy was overthrown and the great country assumed the republican form of government.

This great political revolution has been accomplished without bloodshed. The causes which led to it have been working like a yeast for a long time, and the transition, although sudden and complete, took place without any serious public or commercial disturbance.

Brazil has an area almost the same as that of the United States, namely, three millions of square miles. Her natural resources are of the richest description.

There is reason to believe the adoption of the new and more liberal form of government will lead to a great extension of trade between this country and Brazil. We are purchasing from her annually at present about forty millions of dollars worth of her products, and we admit her coffee duty free.

STANLEY'S LATEST DISCOVERIES.

Recent advices leave no room for doubt of the safety of Stanley, the African explorer, whose arrival within actual reach of the telegraph may be daily looked for.

Since the latter part of the year 1887, when the explorer left Stanley Falls, on the Upper Congo, the news from him has been very meager, and that which did come was anything but hopeful, especially when taken in connection with the reports that Emin's settlement had been broken up and Emin himself was a prisoner in the hands of the Mahdi.

The additions made by the explorer to our knowledge of the geography of this vast region in Central Africa are necessarily limited by the meagerness of the accounts so far received, but it is seen that they will be of great importance.

It will probably be a wonderful and thrilling story which the adventurers will have to tell when they finally reach home, and it will also be a story of hardships and privations endured, of sickness, want of food, and unremitting toil of the severest kind under the blaze of a tropical sun or in the more deadly African morasses and jungles.

OUR NEW BOOK.

Probably no book on physics ever reached so great a sale in so short a time as our new book "Experimental Science," by Mr. George M. Hopkins, treating on elementary practical and experimental physics.

Prof. E. S. Dana, of Yale University, New Haven, Conn., writes: "I shall expect myself to obtain from it many suggestions which will aid in my instructions."

Prof. John Trowbridge, Jefferson Physical Laboratory, Cambridge, says: "It will do much to popularize the great subject of physical science."

Prof. S. P. Langley, Smithsonian Institution, Washington, D. C., writes: "Many of the experiments and illustrations are new to me."

Prof. D. W. Hering, University of the City of New York, says: "I know of no work that is at the same time so popular in style and so scientific in character."

Prof. W. C. Peckham, Adelphi Academy, Brooklyn, N. Y., says: "Of few such books can the author say that all the apparatus has been constructed and the experiments performed by himself before the descriptions were admitted to the book."

The following is from Prof. W. Le Conte Stevens, of the Packer Collegiate Institute, Brooklyn, N. Y.: "The author is accurate in statement, full of ingenious suggestions, plain and simple in style, and admirably clear in his mode of presentation."

Prof. Samuel Sheldon, Polytechnic Institute, Brooklyn, N. Y., writes: "The book will be of great value to those teachers and instructors who are expected to fully illustrate the subject of physics, and yet have but a small amount of apparatus, and that badly chosen."

Prof. Robert Spice, of Brooklyn, says: "I must congratulate you on the production of such a splendid and valuable work."

Prof. R. H. Thurston, director Sibley College, Cornell University, Ithaca, N. Y., says of the book: "It is full of ingenious and effective arrangements in experimentation and crowded with interesting matter."

Mr. Thomas A. Edison says: "The practical character of the physical apparatus, the clearness of the descriptive matter, and its entire freedom from mathematics give the work a value in my mind superior to any other work on elementary physics of which I am aware."

Prof. W. J. Rolfe, of Cambridgeport, Mass., writes: "The book is by far the best thing of the kind I have seen, and I can commend it most cordially and emphatically."

THE AMERICAN EXHIBITION OF 1892.

The citizens of New York have completed their subscription of five millions of dollars for the celebration by an International Exhibition, to be held in this city in 1892, of the four hundredth anniversary of the landing of Columbus.

So far as money for buildings, grounds, and all the paraphernalia of the great exhibition is concerned, everything needful is provided. A magnificent site of several hundred acres in the heart of the city has been selected, convenient and accessible from all directions by land and water.

erly to the Hudson River, embracing the Morningside Park, the Riverside Park, and the intervening grounds as far north and south as may be required, have been selected. Nothing could surpass the beauty and excellence of the chosen location. There is every promise of the assembly here in 1892 of a more wonderful display of industry, science, and art than has ever been realized in the history of the world.

BREWING CHEMISTRY.

Those who know anything about the condition of the manufacturing industries abroad are aware of the state of development they have reached and how scientific investigators are constantly called on to procure the best possible results for the minimum expenditure of time, labor, and money. Experimentation is in the hands of scientists, no brewery for example being complete without its expert chemist. In this industry, as a result, there are scientific brewers' magazines of a very high order, contributions on practical brewing find a place in the leading chemical *Zeitschriften*, a literature on the subject is found in works on applied chemistry, a number of valuable text books have been printed, the chemistry of brewing is taught in the technical schools, etc. There are scattered through this country a few experts who do work, occasionally, for the various breweries, but who hitherto have not played the important role one might expect when he considers the enormous sums of money invested in these enterprises. The operations of the English breweries syndicate revealed but a small part of the capital stock.

The all-important personage in these establishments is the *braumeister*, a very practical person in his specialty, but usually one who is densely ignorant otherwise, and as obstinate as he is ignorant. Suggestions from scientific experts are received by him in the worst possible humor, for he regards the brewer's chemist as a wanton persecutor. Any hitch in the normal workings of the brew he ascribes at once to poor material, and cannot appreciate that his treatment may be faulty. He needs the chemist and the latter needs him in lager beer making in America.

This last is quite different from that pursued in England and Germany, where the government considers any ingredient in the manufacture of beer other than pure malt, hops, yeast, and water an adulterant, whose use is prohibited and is finable. In this country, on the contrary, it is the general rule, and not the exception, to substitute for at least part of the malted barley a variety of cereals, such as corn, prepared in several ways, wheat, oats, and rice, also sugar and glucose. The hops sometimes find their place taken by "hop aroma" and "hop auxiliary," while caramel, "beer color," and other chemically prepared substances (all more or less dangerous to the health) give color to the beer; alum, fish sounds, isinglass, shavings, etc., are used to clarify it, and a variety of preservative solutions, antacid tablets, sulphites of lime, soda, or potash, bicarbonate of soda, or salicylic acid—all of which are objectionable from a sanitary standpoint—are used to preserve the beer, destroy the acid, and make it ready for export. Ostensibly the reason for these adulterations is to make more money for the brewer. The chemical expert will tell you, however, that barley grown in artificially fertilized ground has other properties than those usually ascribed to the pure article by brewers and chemists, and that these deficiencies in the American product must be compensated by introducing new conditions. This departure from the beaten track of brewing, pure and simple, is what makes the brewer's chemist not only useful, but more or less of a necessity.

Take a sample of beer to a good analyst, and he can tell you its deleterious impurities, such as salicylic acid, sulphites, etc.; he can ascertain for you the exact quantity of water and extractive solids, alcohol and sugars, nutritive and non-nutritive substances, etc. The brewer's chemist, besides this, must do synthetic work, he must solve such a problem as the following: Given a sample of beer with a certain definite taste, color, and other physical properties, which a brewer, for reasons of his own, desires to imitate, to find a complete brewer's formula.

This will include the proportions of the several ingredients to be used and all the details of the subsequent operations of grinding and washing the malt, extracting the wort, boiling it with hops, the fermentation at a given temperature with a certain kind of yeast, clarifying, preserving, racking, etc. A bacteriologist can easily recognize the yeast plant under the microscope, but the brewer's chemist must instantly point out the various kinds of vegetable ferments in a sample of yeast, know the action of each, and be able to state whether or not this or that predominant species of *saccharomyces* is to give his beer the desired color, taste, and facility of separation of the yeast, and to act accordingly. A chemist can determine the quantity of soluble protein in the malt, and thence the approximate amount of the chemical diastase present which is to change starch to grape sugar, ready for conversion thence by the yeast plant into alcohol and carbonic acid. The specialist must also, besides

this, know how to recommend substitutes for the malt, and present simultaneously a complete brewer's formula; if there be something wrong with the brew, he must provide a remedy at once, else his enemy the *braumeister* will call him a worthless being; he must be up to all the tricks of the trade in changing the color and taste, and in preparing the beer for export by means of chemicals.

Thus it will be seen that the brewer's chemist must be a practical *braumeister* and have in miniature a complete brewer's outfit. He must be a good analyst and microscopist, though devoted to a specialty in both fields. For all this he is not to be underpaid, for successful brewers are known to accumulate fortunes rapidly, and therefore can afford to be liberal. In point of fact, such chemists are well paid, even in Germany and England, the chief chemist of one large establishment in Great Britain receiving £10,000 per year. Brewers are having their sons educated in the one large brewer's laboratory in New York City, and it is said there is soon to be a great demand for chemists expert in this field. Some are being brought over surreptitiously from abroad; but there is a disposition to employ native talent if it can be procured. This, then, is a promising field for the investment of time and money by the college graduate, and it would be well even for the technical schools to give it a place in their curriculum. There is money in it, and a prospect of employment for the many.

POSITION OF THE PLANETS FOR DECEMBER.

SATURN

is morning star, and his movements during the month form an interesting study. He rises about 11 o'clock on the first of the month and about 9 o'clock at the close of the month. He has been moving eastward, or in direct motion, but is stationary on the 15th, and then moves westward, or in retrograde motion. He will, therefore, approach Regulus, the bright star on the west of him, and will meet and pass the star on March 29th of the coming year. The planet may be readily found, rising about 10 o'clock on the middle of the month, and being at that time about 5° east of Regulus. Saturn rises on the 1st at 10 h. 55 m. P. M. On the 31st he rises at 8 h. 56 m. P. M. His diameter on the 1st is 17".2, and he is in the constellation Leo.

MERCURY

is morning star until the 7th, and then evening star. He is in superior conjunction with the sun on the 7th, at 7 h. P. M., and after that event commences his eastward journey from the sun. He meets Jupiter on his way, who is journeying westward toward the sun. The two planets are in conjunction on the 26th, at 8 h. 35 m. P. M. Mercury rises on the 1st at 6 h. 56 m. A. M. On the 31st he sets at 5 h. 31 m. P. M. The diameter of Mercury on the 1st is 4".6, and he is in the constellation Scorpio.

JUPITER

is evening star. He is very near the sun, setting about a half hour later than the sun at the close of the month. Jupiter sets on the 1st at 6 h. 34 m. P. M. On the 31st he sets at 5 h. 8 m. P. M. His diameter on the 1st is 31".4, and he is in the constellation Sagittarius.

VENUS

is morning star. She, like her rival Jupiter, is near the sun, though on his western, while Jupiter is on his eastern side. Bright-eyed observers may still behold the fairest of the stars in the first half of the month, for she rises more than an hour before the sun, and is low down in the southeast. Venus rises on the 1st at 5 h. 31 m. A. M. On the 31st she rises at 6 h. 38 m. A. M. Her diameter on the 1st is 10".8, and she is in the constellation Libra.

MARS

is morning star. He may be readily found from his vicinity to Spica during the month. He passes the bright star on the 15th. He is in conjunction with Uranus on the 24th. Mars rises on the 1st at 2 h. 13 m. A. M. On the 31st he rises at 1 h. 43 m. A. M. His diameter on the 1st is 5".2, and he is in the constellation Virgo.

URANUS

is morning star. He rises on the 1st at 3 h. 17 m. A. M. On the 31st he rises at 1 h. 24 m. A. M. His diameter on the 1st is 3".5, and he is in the constellation Virgo.

NEPTUNE

is evening star. He may be found between the Pleiades and Aldebaran, and is in fine position for telescopic observation. Neptune sets on the 1st at 6 h. 27 m. A. M. On the 31st he sets at 4 h. 25 m. A. M. His diameter on the 1st is 2".6, and he is in the constellation Taurus. Saturn, Mars, Uranus, and Venus are morning stars at the close of the month. Jupiter, Mercury, and Neptune are evening stars.

SOME THOUGHTS ABOUT CHINA.

In an article in the *SCIENTIFIC AMERICAN* of Sept. 28, 1889, entitled "The Insulted Chinese," Rev. Chas. H. Fowler is quoted as prophesying trouble between the United States and China at no very distant day, on account of the latter's anti-Chinese laws. "I tell

you they are thinking, and trouble is brewing," he is quoted as saying. And again: "They are making great guns and ironclads and manning them."

It is doubtless true that China is making great strides in the art of war; this, however, does not necessarily mean that she is getting ready to retaliate upon the United States for her anti-Chinese laws. But it does mean that China, by the adoption of modern engines of war, of the arms, tactics, and discipline of the West, is rapidly putting herself in position to resist the encroachments and command the respect of other nations. The prejudices of the nation against modern civilization are slowly but steadily breaking down; they may not see in the Christian religion a better one than their own, but they do see the advantages of modern appliances, and in no case have they more clearly illustrated the fact than by the adoption of modern weapons in their armies. The constant intercourse, becoming more intimate every year, between China and the countries of the West renders the introduction, to a greater or less extent, of the civilization of the latter a mere matter of time. That the result of this should be the complete supplanting of the Chinese civilization by that of the West is highly improbable, nay impossible. But the supplanting of the Chinese civilization in many things, and radical changes in many others, seem almost inevitable. The result will naturally be the formation of a new system, of a new civilization in fact, from the intermingling of the old and the new.

And now let us imagine China placed upon an equal footing with ourselves, reinvigorated by the infusion of new ideas and new principles, and, more than all, of the spirit of progress; with her great resources developed by a wise administration; with a large army, well disciplined and supplied with arms and equipments equal to those of the most advanced European nations; and, what would be most dangerous of all, a powerful and numerous navy. These, combined with her enormous population, would make her indeed a formidable foe. At present we have comparatively little to apprehend from a rupture with China, but in the future we may find in her a foeman worthy of our steel. The day may not be far distant when China will be ranked among the most powerful nations of the earth.

And now let us take a glance in the direction of Japan. Here we are astonished by the wonderful progress she has made since Perry's expedition, and especially during the last twenty years. Her power and prosperity are steadily increasing. The recent adoption by Japan of a constitutional form of government was a great advance in the path of progress, and marks a turning point in her history. Japan is destined to be one of the great states of the future.

The Anglo-Indian empire and Australia will not always remain subject to Great Britain. Both of them are likely to become powerful states in the future. It is probable in the next century the Pacific will wash the shores of some of the most powerful if not the dominant nations of the world.

Stephen Freeman.

The name of Stephen Freeman has long been familiar to the farmers and those engaged in the agricultural implement trade in the United States; most of these know him as an enterprising manufacturer and business man who, from infancy, being thrown upon his own resources, had, by his traits of honesty, industry, perseverance, aided by natural ability, gained an enviable position among men, being, in a word, a self-made man, and, as such, will be sorry to learn of his death, which occurred at his home in Racine, Tuesday, September 10, from an attack of pneumonia.

He had but just returned from a short trip to his native home, and seemed to be enjoying the best of health.

Mr. Freeman was born on the island of Angleise, North Wales, 1834, and was left an orphan before a year old. With no opportunity for an education except that gained at a Sunday school and by home study, he was apprenticed in the boiler maker's trade at the age of ten. On the completion of his apprenticeship he moved to Liverpool, where he worked at his trade until 1856, with the exception of nine months spent in the Crimean war.

Mr. Freeman then came to the United States, settling at Rome, N. Y., from which place he went to Chicago in 1857, thence to St. Louis and Centralia, at all of which places he met with varying success. Soon after the opening of the rebellion he entered the United States navy, in the capacity of boiler maker, and remained until 1864, when, on account of poor health, he left the service, and after a short time spent in business at Cairo, moved to Wisconsin, settling first at Milwaukee, then at Watertown, and finally, in 1867, he came to Racine, where he founded the business which now bears his name, and which has grown, largely by his efforts, which have been efficiently aided by his sons, to be one of the best known in the country, the S. Freeman & Sons Manufacturing Company. Mr. Freeman was also president of the Wisconsin Agriculturist Company, publishers of this paper, — *Wisconsin Agriculturist*.

JOHNSTON'S PATENT SIDE DRUM.

The drum shown in the accompanying illustration may be used either for military or orchestral purposes. It is quick of vibration, is strong of tone, and possesses several novel features that have been patented by Mr. W. R. Johnston.

One of these is the brace, which is an oval-shaped metal shell provided internally (see cut) with an elastic

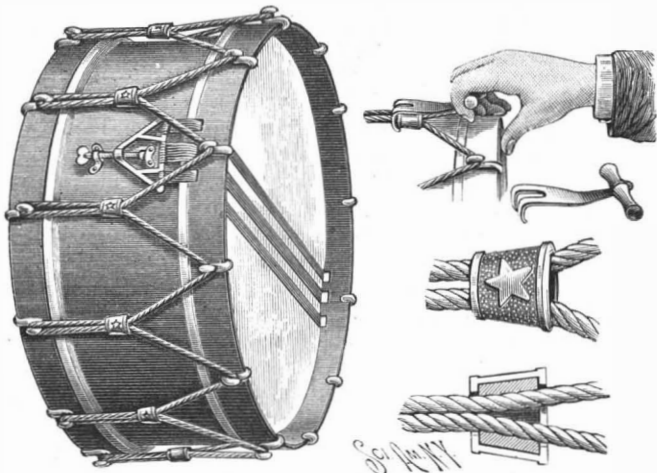

JOHNSTON'S PATENT SIDE DRUM.

fining which serves to prevent the brace from slipping on the cord. It stays where it is placed, and keeps an even pressure on the head. It is light and ornamental and will not slip, stretch, or break. When the head is to be stretched, a bifurcated hook is employed, which is inserted over the brace on each side of the cord. It is also provided with a handle which enables the brace to be drawn down without injury to the fingers. The triple snares which are used in this drum are clamped to the shell of the drum on one side and at the other side are retained by the triangular snare strainer, which is of peculiar construction. Holes are cut in the hoop so that when tension is applied to the snares after they are passed through these openings, they will be drawn close to the snare head, greatly increasing the vibration and tone of the instrument. The snare strainer is triangular in shape and is provided with an opening at its upper end, through which passes the screw tightener. This screw also passes through an apertured lip that is screwed to the side of the drum, so that by simply turning the thumb screw the snare will be tightened and held firmly stretched. This drum has proved so far satisfactory that it was adopted by the Massachusetts Volunteer Militia in June, 1889. The 17 in. by 10 in. drum is used for military purposes, drum corps, etc., and the 14 in. by 5½ in. for the orchestra.

For further information address the patentee, Mr. W. R. Johnston, Waltham, Mass.

AN OPTICAL ILLUSION.

We are going to present to our readers the solution of a problem that came in our way by accident during our peregrinations in search of curiosities of all kinds, and which consists in making a few persons appear like an innumerable crowd. This interesting scientific recreation was exhibited some time ago in a public establishment near the universal exposition. It is now no longer in existence, but doubtless we shall soon have an opportunity of seeing it again at our fete day shows.

The realization of this optical illusion, however, is one of the simplest of matters, and requires the use of but very elementary material.

Let us imagine that three perfectly plain and very clear mirror glasses, as large as possible, form a prism whose base is an equilateral triangle. A person placed in the interior of this prism will see his image reflected a very large number of times. A very simple geometrical construction, and one which we recommend our young readers to carry out as an exercise in optics, by the simple application of the principle that the angle of incidence is equal to the angle of reflection, allows us to see that the image of any point whatever placed in the center of this triangle of glass plates will be reproduced indefinitely by groups of six images distributed symmetrically around points regularly spaced in the prolongations of the planes of the three glasses.

A person, therefore, sees his image reproduced indefinitely

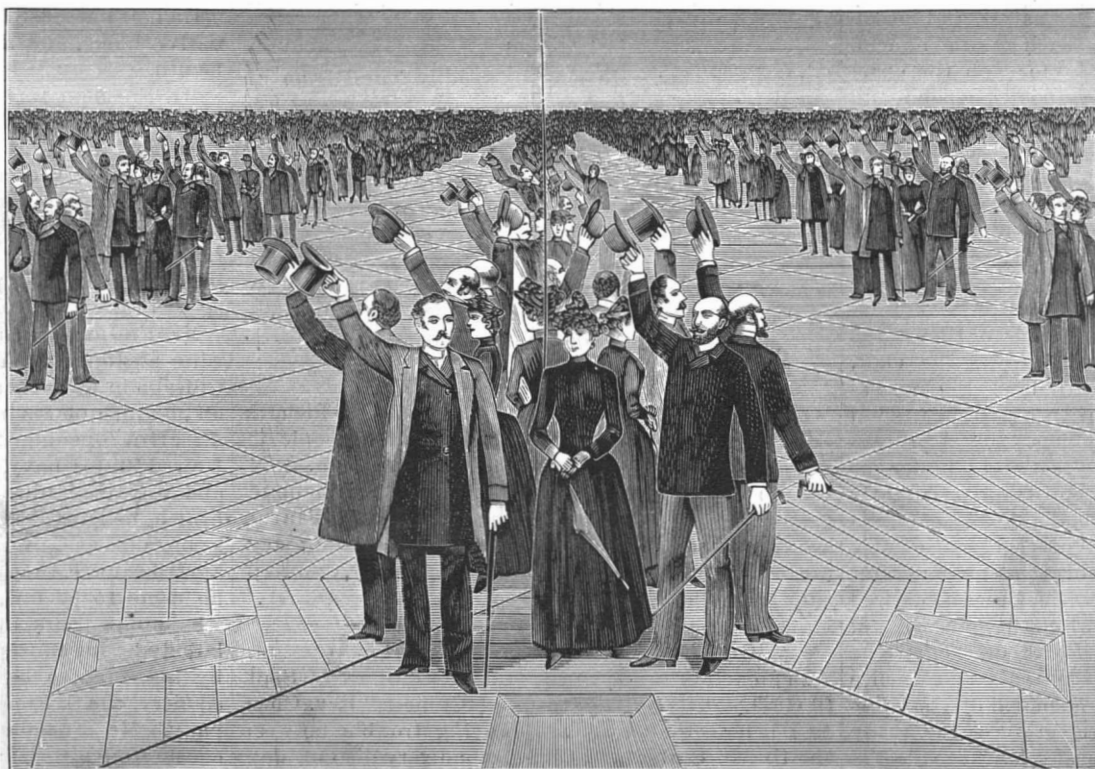

AN OPTICAL ILLUSION PRODUCED WITH THREE MIRRORS.

in groups of six until, the successive reflections attenuating the intensity of the images, the latter cease to be visible. Three or four persons massed in one of the angles present the illusion of a compact and mixed crowd standing upon a sidewalk and awaiting the passage of a procession. The hats waving in the air convert the peaceful waiting into an enthusiastic manifestation, which is so much the more surprising in that it is made by but half a dozen persons at the maximum.

The accompanying figure gives an idea of this remarkable effect, and the three persons, whose images reflected *ad infinitum* produce the curious result that we call attention to, would have much trouble to believe that they were the subject of an illusion.

Upon the whole, the experiment is nothing more than an application of the principle of the old kaleidoscope enlarged and revived, in the sense that the observer has before his eyes the successive reflections of his own image, and that the objects are replaced with living beings movable at will.

Five or six persons may occupy, at the same time, the triangular prism, of which the sides are about six feet wide, and which they enter through a trap in the floor. When these five or six persons are walking about in all directions, they present the aspect of a tumultuous and agitated crowd commenting upon grave events.—*La Nature*.

An Unknown Gas.

Passing Stratton ice works a short time ago, about 6 o'clock, a reporter saw Mr. Ware, one of the proprietors, on top of the huge ammonia machines, intently watching a long jet of flame which was consuming the gas as it issued from a half inch vent pipe in the top of the machine. Inquiring what kind of light it was, the reporter was informed by Mr. Ware that he did not know anything further than that it was gas which, by some mysterious process, is generated in the "absorber" during the process of ice making with ammonia, and which often creates such a back pressure as to necessitate prompt attention in giving it vent to relieve the machine. The gas burns with a dull greenish flame, but is quite combustible; and while the matter was being discussed by them, the supply was exhausted and the flame went out with a sputter. Mr. Ware then said that there would be no more trouble with it for twenty-four hours, when another accumulation would take place. He further said that no chemist had as yet been able to explain the nature of the gas or why it is generated in this manner.—*Pensacola News*.

[The mystery of the above is probably not very deep. The greenish color of the flame at once betrays its ammoniacal nature or the presence of some ammoniacal compound. Under the conditions of pressure, presence of organic matter from lubrication, etc., it is easy to conceive that a combustible gas could be generated which would contain enough ammonia to give a green color to the flame. Examination by a competent chemist would soon determine the composition of the gas.—*Ed. S. A.*]

A Grand Prize to the Worthington Pumping Engine Company.

In our list of awards at the Paris exhibition, given in SUPPLEMENT, Nos. 722 and 723, the award of a grand prize to the above company was in some way omitted. We are glad now to make the correction.

AN IMPROVED DISH DRIER.

A drier designed to save the work of wiping dishes has been patented by Mrs. Alice J. Wilson, of Abilene, Texas, and is shown herewith. It has a perforated hinged cover, and in its base is held a perforated false bottom, a spout leading from the chamber thus formed, by means of which the drainage water accumulating there may be poured off. A curved projecting piece

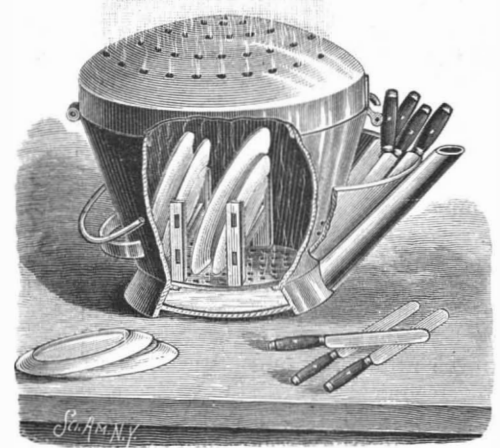

MRS. WILSON'S DISH DRIER.

of sheet metal is secured to the side of the body to form a chamber in which knives, forks, and spoons may be placed to drain and dry. Uprights attached to the false bottom support cross pieces, against which the dishes to be dried are placed. The dishes are washed, turned down in the drier, and hot water poured over them, when the cover is closed and the heat remaining will effect the drying and give a glossy appearance, the steam passing off through the perforations of the cover.

AN IMPROVED VIOLIN TAIL PIECE.

In most cases the breaking of violin strings takes place near where the fingers come in contact with the

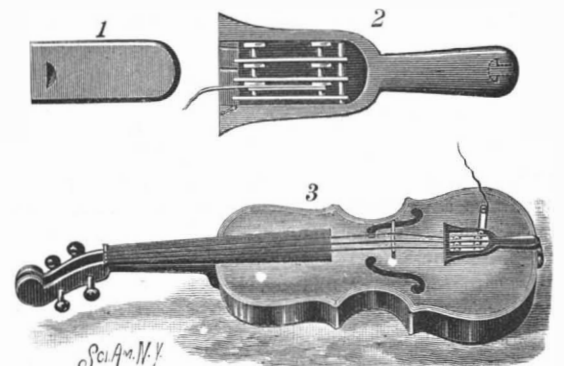

SNOW'S VIOLIN TAIL PIECE.

strings in playing, the broken string being then useless if it consists only of one length. To avoid this waste several lengths of string are sometimes coiled about the tail piece, a portion to be uncoiled at each breakage, but this arrangement is awkward and unsightly, and to overcome the difficulty is the object of an invention illustrated herewith, which forms the subject of a patent issued to Mr. F. P. Snow, of Portland, Oregon. The tail piece has a chamber in its larger part, closed by a sliding cover, shown in Fig. 1, and in this chamber metal plates or bars lie parallel, as in Fig. 2, these plates being all pivoted at one end. The free

ends of the plates are held in suitable recesses, but so that such ends can be swung upward when desired, as shown in Fig. 3, and each plate has on its side two studs, each plate with its studs forming a kind of bobbin around which the string is wound in an elongated coil. The chamber in the tail piece is preferably made with a bottom, and the whole mechanism inclosed, the strings passing out from the chamber through small channels or recesses. Usually but three bobbins are employed, the G string being attached to the tail piece by passing it through a concealed hole and tying a knot in its end.

A CITY ordinance lately passed at Cleveland, and which gives popular satisfaction, forbids the blowing of steam whistles. The manufacturers find that the use of the screechers is not necessary.

AN IMPROVED MECHANICAL MIXER.

The accompanying illustration represents a mixer, patented by Mr. Milton Broughton, expressly designed to thoroughly mix patent wall plaster, and equally suitable for mixing fertilizers, sand, lime, cements, etc. The machine is represented as occupying a portion of two floors of a building. The material to be mixed is received in the hopper-like top portion of the machine, in the bottom of which are two iron doors, the doors being attached to shafts geared together outside of the casing, a worm meshing into one of these gears and attached to a vertical shaft having a handle on its upper end affording ready means for opening and closing the doors and regulating the feed as desired. In the mixing chamber, the interior of which is seen through the partially broken away casing, are two horizontal shafts geared together to run side by side in opposite directions, paddles being placed upon the shafts in screw

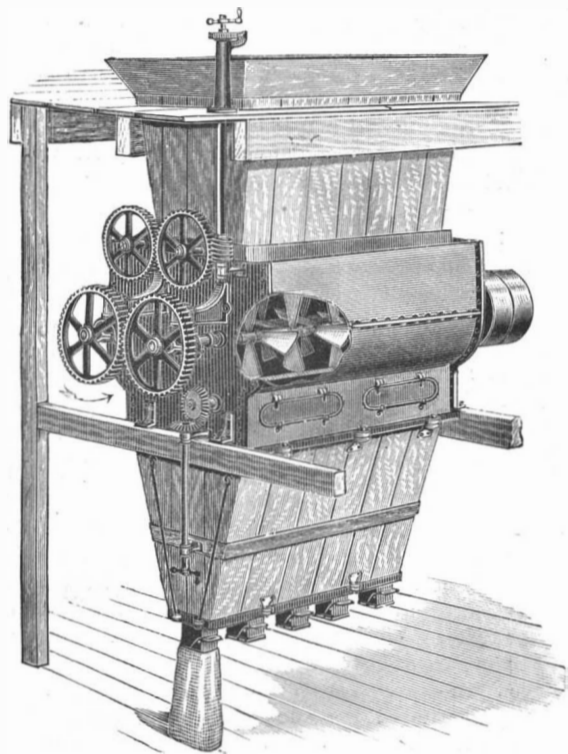

THE BROUGHTON MIXER.

form, so that as the shafts are rotated, the material is lifted and thrown in opposite directions from one end of the case to the other, the constant motion insuring a thorough mixing. After the completion of the operation the material is dropped into a lower receiving chamber by means of two sliding doors that run on ways and open directly under the center of each set of paddles, the shaft connected with these sliding doors being connected by a gear with a rod having a hand wheel, whereby the operator may conveniently remove the material to bags or other receptacle provided therefor. The upper doors controlling the feed to the machine may also be connected to be operated from the same point. The doors from the receiving chamber are easily accessible and readily adjustable through openings in the sides of the case, and the edges of these doors are steel ground to a knife edge in shear form, so that they will cut fiber or any other light obstruction. The mixing chamber and all working parts are of iron and steel, making the machine solid and durable, and easy to operate.

This machine is manufactured by Messrs. Alexander, Bradley & Dunning, of Syracuse, N. Y.

AN IMPROVED COMBINATION LOCK.

The lock shown in the illustration is designed to

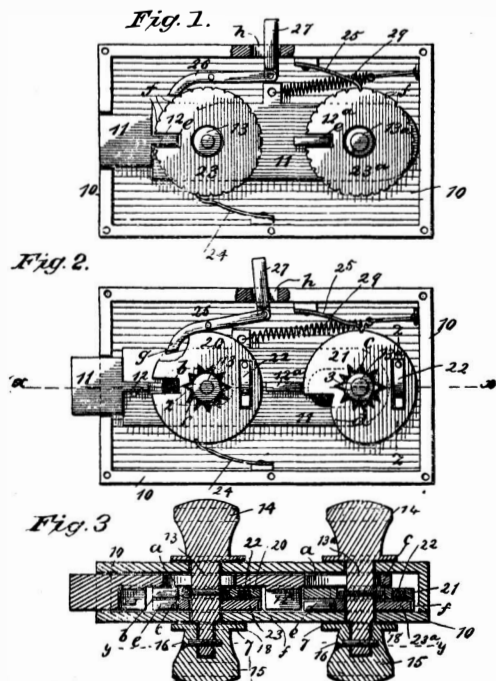

DOUGLASS' COMBINATION LOCK.

afford increased security, as compared with other locks of this class, and at the same time be more simple in construction. It has been patented by Mr. George M. Douglass, of Benedict, Neb. Fig. 1 is a sectional view, with the bolt retracted, Fig. 2 being a similar view with the bolt in locking position and one set of the operating disks removed, while Fig. 3 is a central longitudinal sectional view. The bolt, 11, has projections, 12 and 12a, on one side, and two longitudinal slots through which pass spindles, 13 and 13a, having knobs, 14 and 15, there being in connection with each of the knobs a dial and pointers upon the lock case. Upon spindle 13, as shown in Fig. 2, is mounted a disk having a slot, b, this disk being held to turn with the spindle by a pin engaging one of a series of notches formed in star shape centrally in the disk, and upon spindle 13a, shown in the same figure, is a disk with a recessed peripheral face, one side of the recess corresponding with the slot, b, and having adjacent thereto a cam face. In the side faces of these disks are spring tongues, 22, adapted to engage the slots, e, of other disks, 23 and 23a, shown in Fig. 1, the latter disks being loosely mounted on the spindles, and having notched peripheral faces. These notches are adapted to be engaged by spring fingers, 24 and 25, preventing retrograde movement of the disks. Upon one side of the bolt is a notch, g, whereby the bolt when thrown may be engaged by a lever, 26, pivotally mounted in the case, and having a thumbpiece, 27, extending outward through a slot in the upper wall of the case. The bolt is normally held retracted by a spring, 29. To draw the bolt, the operator, understanding the combination, turns the knob to bring the spring tongues on the disks shown in Fig. 2 into engagement with the slots, e, on the disks shown in Fig. 1, the motion being continued until the slots are brought into line with the projections on the bolt. The motion of the knob is then reversed until the slot, b, of the disk, 20, and the recess, 3, of the disk, 21, register with the projections on the bolt, when the spring, 29, draws the bolt. The bolt is thrown by turning the spindle, 13a, to bring the cam face of the disk, 21, against the rear lug on the bolt, when the bolt is locked by means of the lever, 26.

REVERSING ATTACHMENT FOR TYPE WRITERS.

The accompanying illustration represents an attachment for type-writing machines whereby, as a line is completed, the carriage is drawn back to its original position, and the paper turned up for a new line, simply by moving a lever, that is in convenient position to be pressed against by the knee, the hands not having to be removed from the keys. The invention has been patented by Mr. George Gledhill, law reporter, of Oswego, Kansas. The attachment is shown applied to a Remington machine, Fig. 2 showing that part of the upper end of the attachment connected with the machine. Its base piece may be secured to the type writer direct, or to the stand upon which the machine rests, by means of a spring clamp at one end and ordinary screws in other places. A shaft is journaled parallel with the base piece, a short arm projecting outwardly and upwardly from the shaft being connected by a link with one arm of a bell crank lever pivotally secured on the under side of the clamp, the other arm of this lever forming a downwardly extending handle in convenient position to be pushed by the knee, by means of which the shaft parallel with the base piece is turned through part of a revolution. From the other end of this shaft projects a longer arm which is connected with the carriage of the machine by means of a strap and a bell crank tripping lever, pivotally secured to the side of a collar fitting on the support for the paper table. The arrangement is such that when the lever below the machine is moved from right to left by the knee of the operator, the shaft parallel with the base piece is rotated, swinging outward the arm projecting from its farther end, and drawing the carriage after it, the cord or strap connecting the arm with the carriage permitting the arm to move in the arc of a circle. For turning up the paper for a line space, a lug is attached to the rear end of the line space handle, the point of the lug projecting below the tripping lever, which engages with the top of the lug whenever the tripping lever is swung downward upon its pivot. The leverage of this lever is so great that before the carriage starts upon its return trip the roller is turned up one or more spaces, as desired, this being regulated in the ordinary manner for a greater or less space between the lines. When the carriage is drawn back, and the pressure of the knee released, the tripping lever is raised by the mechanism of the machine for retracting the line space mechanism for a new line.

It is said that this attachment has been proved entirely practical in actual use, the operator not having to touch the line space handle except to put in a fresh supply of paper.

AN IMPROVED ORGAN PALETTE.

The accompanying illustration represents a metallic pallet for organs, constituting a new article of manufacture, which can be cheaply made in large quantities and kept on hand by organ makers, to be used when building the organ, instead of wooden pallets. The invention forms the subject of a patent issued to Mr. Gaspard O. Girardin, of Lake Linden, Mich.

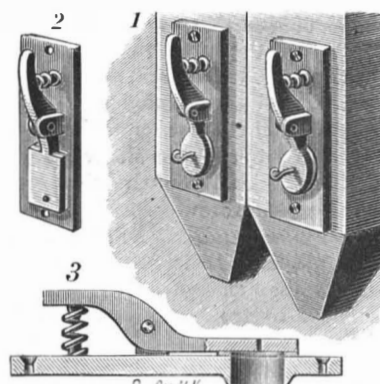

GIRARDIN'S ORGAN PALETTE.

The base is preferably of cast iron, with an air opening and screw holes for fastening the plate to the wind chest, as shown in the sectional view, Fig. 3. On the under side of the base are lugs between which is pivoted a lever having near one end a lug on which is held one end of a coiled spring, the other end of the spring resting around a similar lug on the base. The end of the lever opposite the spring carries the valve proper, adapted to open and close the air opening, the valve being pressed against a seat of leather or other suitable material. In the middle of the valve is a small hole for fastening a hook or loop, as shown in the perspective view, Fig. 1, and generally used to hook on pull downs. Fig. 2 shows a modified form of the pallet with an oblong air opening and correspondingly shaped valve, for sound boards requiring channels on account of the slides for the different stops.

AN IMPROVED FAMILY ICE MACHINE.

A simple and easily operated machine for making ice, ice cream, iced champagne, cooling water for drinking,

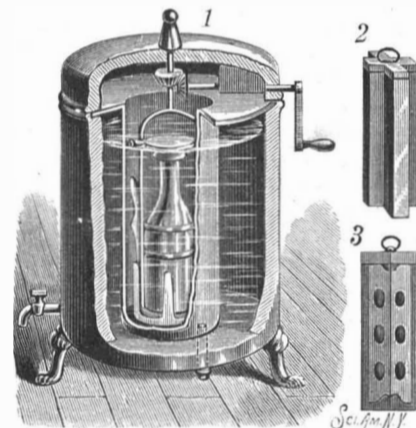

DERMIGNY'S FAMILY ICE MACHINE.

etc., is shown herewith, and has been patented by Mr. Paul L. Dermigny. Fig. 1 shows the machine with a bottle in place for cooling, Fig. 2 being an ice mould and Fig. 3 an ice cream mould, to be substituted for the bottle when desired. An inner receptacle is placed within an outer one to form a space between them to hold water to be cooled, a faucet at the lower end affording means for drawing the water as needed. The upper end of the inner receptacle has an outwardly extending flange forming a cover over the water space, and there is here a covered opening for introducing water to the water space, there being also an outlet pipe leading from the bottom of the inner receptacle, which may be charged with any suitable freezing mix-



GLEDHILL'S ATTACHMENT FOR TYPE WRITERS.

ture, such as sulphate of soda and hydrochloric acid. The inner vessel is charged with the freezing mixture by removing the cover of the outer receptacle. Centrally in the bottom of the inner receptacle is a spindle on which is the disk of an agitator mounted to turn in the freezing mixture. The disk preferably has short upwardly extending arms in which a bottle may be placed, and longer arms having side agitating wings, which join a vertical shaft in the upper part of the receptacle, this shaft having a bevel gear meshing with the bevel gear of a horizontal shaft provided with a crank handle on the outside of the freezer. The bottle is firmly held in the agitator by a cone-shaped cover secured on an arm sliding vertically on the side rods, and adjusted in position by set screws, the ice cream mould and the ice mould being similarly held when the freezer is to be thus employed. It is designed, with the use of comparatively inexpensive refrigerants, to make ice in this machine in from ten to fifteen minutes.

For further information relative to the invention address Messrs. L. Dermigny & Co., No. 126 West Twenty-fifth Street, New York City.

A Norwegian Settlement in Massachusetts Five Hundred Years before Columbus.

Watertown, Mass., one of the oldest towns in Massachusetts, celebrated on Nov. 24 the discovery of the ancient town or city of Norumbega by Professor Eben Norton Horsford, of Harvard University. The exercises were held under the auspices of the American Geographical Society at the tower erected near the junction of Stony Brook with Charles River, which marks the spot where the remains of Norumbega are said to have been discovered, and consisted of a sketch of the researches of Professor Horsford; an address by Judge Daly, president of the society; a Swedish folk song by Madam Zela; poem by Mr. E. H. Clement; and a hymn composed by Miss Louise Manning Hodgkins, and sung by a choir from Norumbega Hall, Wellesley College.

At the opening of the exercises Professor Horsford made the following announcement: "It is now nearly five years since I discovered on the banks of Charles River the site of Fort Norumbega, occupied for a time by the Bretons some four hundred years ago, and many years earlier still built and occupied as the seat of extensive fisheries and a settlement by the Northmen. It is nearly five years since the discovery was the subject of a communication which I had the honor to address to you, in your official capacity, on the first of March, 1885, and which was published in the October bulletin of the American Geographical Society of the same year.

"I have to-day the honor of announcing to you the discovery of Vinland, including the Landfall of Leif Erikson and the site of his houses. I have also to announce to you the discovery of the site of the ancient city of Norumbega."

The following is the inscription on the tablet let into the tower:

"A. D. 1000. A. D. 1889. Norumbega. City: country: fort: river. Norumbega = Norumbega. Indian utterance of Norbega, the ancient form of Norvega, Norway: to which the region of Vinland was subject. City at and near Watertown. Where remain to-day docks, wharves, walls, dams, basin. Country extending from Rhode Island to the St. Lawrence. First seen by Bjarni Herjulfson, 985 A. D. Landfall of Leif Erikson on Cape Cod, 1000 A. D. Norse canals, dams, walls, pavements, forts, terraced places of assembly, remain to-day. Fort at base of tower and region about was occupied by the Breton French in the 15th, 16th, and 17th centuries. River the Charles discovered by Leif Erikson 1000 A. D. Explored by Thorwald, Leif's brother, 1003 A. D. Colonized by Thorfinn Kurlsefni 1007 A. D. First Bishop Erik Gnupton 1121 A. D. Industries for 350 years. Masur-wood (burs), fish, furs, agriculture. Latest Norse ship returned to Iceland in 1347."

Prof. Horsford recounted narratives of Verrazano, Parmentier, and other explorers, relating to the reported existence of the remains of Norumbega as somewhere between the site of Gloucester and the headwaters of the Charles. The name appeared on their maps.

There are monuments of the presence of the Northmen, said Prof. Horsford, on every square mile of the basin of the Charles. As evidences of this he alluded to the canal walled on one side for a thousand feet along the west side of Stony Brook and to the dry canal near Newtonville. There were also remains of canals, ditches, boom dams, ponds, fish traps, dwellings, walls, and amphitheatres scattered all throughout the basin of the Charles.

IN the suit in the Eastern District, of the Bridgeport Wood Finishing Company vs. New York Wood Finishing Company and others, for infringement of the celebrated Wheeler patent covering the use of ground silex, quartz, feldspar, etc., in a wood filler, subpoenas have been served on all the defendants, citing them to answer on the first Monday of November, 1889. Application for an injunction, during the pendency of the suit, will be made to the court.

HEAT.*

Heat is the manifestation of an extremely rapid vibratory motion of the molecules of a body. An increase in the velocity and amplitude of the vibrations increases the temperature of the body. A heated mass can impart vibratory motion to the ether which fills space and permeates all bodies, and these wave motions of the ether are able to reproduce in bodies motions similar to those by which they were caused.

The more obvious effects of heat are expansion, fusion, and vaporization. All bodies increase in volume when heated, gases being the most expansible, liquids next, and solids the least. Heat may partially or wholly balance molecular attraction. Hence it is that,

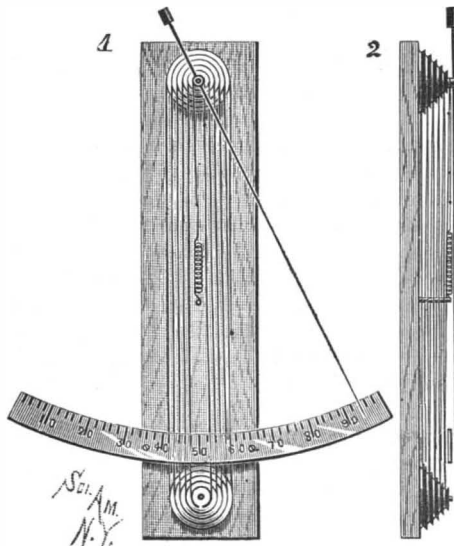

Fig. 1.—METALLIC THERMOMETER.

when heated, solids first expand, then (if no chemical action occurs) soften and become liquid, and finally vaporize. Liquids are changed into vapors, and gases are rarefied.

EXPANSION.

Expansion takes place in all directions. To render this phenomenon apparent, an elongated and attenuated body, such, for example, as a fine wire, is chosen and its linear expansion only is noted. Fig. 1 shows an instrument for exhibiting the linear expansion of a long thin wire, 1 and 2 being respectively front and side views. The instrument is provided with two series of hard rubber pulleys mounted on studs projecting from a board. A fine brass wire (No. 32) attached to the board at one end passes around the successive pulleys of the upper and lower series in alternation, the last end being connected with one end of a spiral spring, which is strong enough to keep the wire taut without stretching it. The other end of the spring is attached to a stud projecting from the board. The pulleys are of different diameters, so that each series forms a cone. By this construction the wire of one convolution is prevented from covering the wire of the next.

The last pulley of the upper series is provided with a boss, to which is attached a counterbalanced index. A curved scale is supported behind the index by posts projecting from the board.

The series of pulleys are 12 inches apart, and there

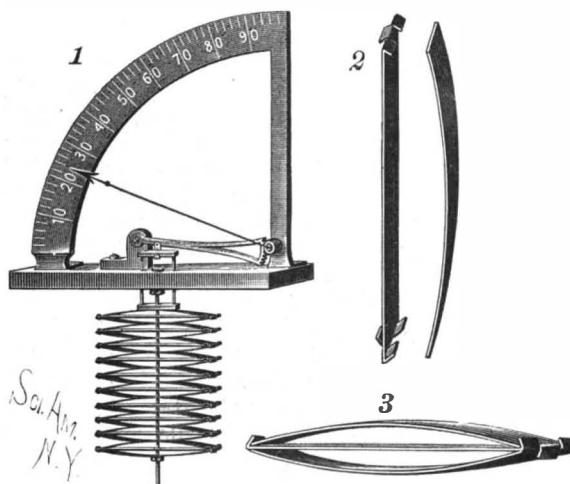

Fig. 2.—THERMOSTAT.

are ten convolutions of wire, so that a small change of temperature produces sufficient expansion of the wire to cause a perceptible movement of the index. To increase the sensitiveness of the instrument, the wire is blackened by means of smoke or dead black varnish. An electric current passing through the wire heats it sufficiently to cause a deflection of the index, the amount of deflection depending, of course, upon the strength of the current.

Fig. 2 shows a simple thermostat which is capable of many useful applications. It is represented with an index and scale, but these are not essential for most purposes.

* From "Experimental Science," by George M. Hopkins. Munn & Co. publishers, New York.

The instrument depends for its operation on the difference between the expansion of brass and steel. The linear expansion of brass is nearly double that of steel, so that when a curved bar of brass is confined at the ends by a straight bar of steel, the brass bar will elongate more than the steel bar when both are heated, and will in consequence become more convex.

At 2 are shown two bars, the straight one being of steel, the curved one of brass. The steel bar is slit for a short distance in two places at each end, and the ears thus formed are bent in opposite directions to form abutments for the ends of the curved brass bar, two brass bars being held by a single steel bar, thus forming a compound bar, as shown at 3. Each compound bar is drilled through at the center. Ten or more such compound bars are strung together loosely upon a rod, which is secured to a fixed support. A stirrup formed of two rods and two cross pieces rests upon the upper compound bar and passes upward through the support. Above the support it is connected by a link with a sector lever which engages a pinion on the pivot of the index. The use to which the thermostat is to be applied will determine its size and construction. It may be used in connection with kilns and ovens and for operating dampers, valves, and electric switches.

Decline of Natural Gas at Pittsburg.

The Pittsburg correspondent of the Philadelphia Inquirer writes:

"The fact that the natural gas supply in this and adjoining districts has passed the zenith and is now upon the wane can no longer be satisfactorily denied. The people, from the wealthy manufacturer to the humblest employe, have been hoping against hope that the plausible explanations given by the various companies for the shortage would prove true. The reason which has usually been given to the inquiring public was that new mains were being laid to the wells, or that the size of those already down was being increased. These changes have all been made, and still the desired fuel does not pour through in the necessary quantities. This state of affairs was first noticed the latter part of last winter, but the warm weather relieved the pressure for domestic purposes, and nothing was heard of a shortage during the summer months. But with the first appearance of a change of temperature this fall, the trouble recommenced in an aggravated form.

"The last move of the natural gas companies has been to ask the big mills to run only at night, when the demand upon the fuel for other purposes would be light. This request was vehemently opposed by the employes affected, and no satisfactory settlement has yet been made. Many of the establishments have decided to return to the use of coal, and some have already done so. But even under these circumstances, the supply at night is not sufficient, as several newspaper offices in the city could bear testimony if they so desired.

"All of the electric light plants in the city were forced to suspend operations for a time, the other night, because of a lack of power, and the inconvenience and annoyance, not to speak of positive financial loss, has been great in many instances. The apparent result of the whole trouble will be that natural gas will be transformed from an ordinary fuel into a luxury. There will probably be enough for residence use for years to come, and those who can afford it will have it, because of its superiority to coal, notwithstanding the difference in price.

"This condition prevails not alone in Pittsburg, but in the surrounding districts. In the Beaver Valley the Citizens' Gas Company announced an advance of about 11 per cent over last year, and a Bridgewater company has not only raised its rates, but has issued and ordered to all manufacturing consumers that all contracts have been withdrawn and that hereafter no gas can be furnished them. This will have the result of compelling manufacturers to return to the use of coal. The Bridgewater gas company also announces that none but dwellings will be accommodated in the future.

"The Beaver Falls Gas Company has returned to the use of coal, and several other factories are making preparations to follow suit. Advices from the gas belt of Ohio and Indiana show that the same state of affairs, while possibly not so far advanced, is already noticeable. There is a general hope throughout the region affected that in the case of the practical failure of the natural gas supply, which it is now conceded can not be averted, a manufactured fuel gas will be found to take its place. Unless some such plan is successful, it is difficult to see how companies owning the miles of main and other facilities can avoid heavy financial losses."

THE tide tables for the Atlantic coast of the United States for the year 1890, published by the U. S. Coast and Geodetic Survey, are now ready for issue, and copies can be obtained at the agencies of the survey in this city, or by addressing the office at Washington. Price 25 cents.

THE NEW DRY DOCK, BROOKLYN NAVY YARD.

The pioneer in the building of timber graving docks was Mr. J. E. Simpson, the senior member of the firm of J. E. Simpson & Co., of this city. For many years he upheld the superiority of wood over stone for these structures. The points made in their favor are numerous. Their original cost is comparatively low. They resist the action of frost much better than do stone docks, whose members are apt to be dislodged by successive winters. Hence the repairs required are less than for stone structures. From the standpoint of practical working they possess valuable features, when constructed upon Mr. Simpson's system. The material is safer and better for the workmen than is stone. The steps are so low that they can easily be mounted. As they entirely surround the dock, no choice of a place to go to or from work is needed. In severe weather ice is not so liable to form and remain upon wood as on stone.

Thus it is clear that many practical points of merit can be cited. At first sight they would appear of a more temporary character than stone, yet this does not seem confirmed on examination. The first dock of this type was built in Boston in 1853 and 1854. It is still in use and in fair condition. Less than two years later a second dock was completed there. After constant service for twenty years with but slight repairs, part of the woodwork was rebuilt. But this rebuilding only refers to the alters or facing pieces, as the original piles, floor timbers, and abutments are still in use.

The Brooklyn Navy Yard dock, which we illustrate, is one of three contracted for the government by this firm. Hitherto the United States naval authorities have favored stone as the material for graving docks. When they began to consider the expediency of erecting wooden docks, boards of inspectors were appointed by the Secretary of the Navy, to examine existing timber docks, and to report upon the advisability of building such structures for the navy yards. In accordance with the recommendations of these investigators, timber docks were started at three navy yards, at Portsmouth, Va., League Island, Pa., and Brooklyn, N. Y.

The dock represents an excavated basin or slip lined throughout with Georgia pine timber, with sides and inner end sloping to the floor. The outer end is open, and is provided with heavy sill and abutment timbers. An iron caisson fits this opening and acts as a gate. The general dimensions are as follows: Length over all on coping, 530 feet; length over all inside of caisson, 500 feet; width on top amidship, 130 feet 4 inches; width on floor amidship, 50 feet; width on floor at entrance, 53 feet; width on top at entrance, 85 feet; depth of gate sill below coping, 30 feet 6 inches; depth of gate sill below high water, 25 feet 6 inches; depth at center, 32 feet 8 inches.

It will be seen that the sides at the ends are brought together, thus economizing pumping. The general outline conforms in some degree to the outline of a ship. The visible part of the dock is by no means all of it. A great part of the structure is hidden away under ground, the whole being surrounded by close sheet piling that lies twenty-six feet back from the coping.

The structural features are shown in cross section in the cut, one-half only of the dock being included. At the bottom is the floor, fifty feet wide by four hundred and sixty feet long. Around the periphery of this area eight-inch tongued and grooved sheet piling is driven. In good ground the practice has been to drive this down seven and one-half feet. But on account of quicksand, it was driven down forty-five feet in the present instance. The area included within this sheet piling contains round piles, driven in rows, three feet between centers transversely, and four feet in the direction of the length of the dock. Each row of piles carries a longitudinal square timber of Georgia pine. Upon these rest cross timbers three feet between centers, and the planking for the bottom is spiked or bolted to these. This planking is three inches thick. Special rows of piles are driven to carry the keel blocks; a space ten feet wide beneath the center of the dock contains extra closely spaced piling for this purpose. The timber used is in general about one foot square, and the piling twelve inches in diameter.

Under the floor and surrounding the heads of the piles is a bed of Portland cement concrete, five feet thick at the center, and rising toward each side between the transverse timbers to the height of one foot, giving a maximum thickness of six feet. Any water which may find its way thereto runs down to the central axis of the dock, owing to this slope.

From each side of the floor the sides rise in steps with a slope of eight upon ten, or about 39°. They are lined with pieces of ten-inch plank, eleven inches in greatest height, but chamfered off at their rear and lower corner, so that their vertical rear face is only three inches

high. They run horizontally around the dock, forming steps eight inches high and ten inches wide upon the parallel sides. These pieces are termed alters. They are of Georgia pine. They are bolted to side brace timbers that rise, following the same slope from the edge of the flooring. Where the alters cross these timbers, the bolts are driven; one bolt passes through the center of the timber vertically, a second one is driven through the face of the alter diagonally, so as to enter the brace timber perpendicularly. The lower ends of the brace timbers abut upon the floor timbers and also against square longitudinal timbers bolted to the floor and representing the bottom alter. Four piles support each brace timber at equidistant points of its length. A mass of concrete rises six feet up the side, back of the alters, running from two to five feet in thickness. Above this the space back of the alters is rammed with clay, so as to be filled with a compact and almost impervious puddle.

Upon every third floor timber oak bearers are bolted, upon which the bilge blocks slide.

From the interior lines of coping the dock, as stated, is one hundred and thirty feet four inches wide, and twenty-six feet back from this coping line tongued and grooved sheet piling is driven well below the floor level of the dock, so as to completely surround it. This gives a total width of one hundred and eighty-two feet four inches. Four rows of piling with cross caps are driven within this area between sheet piling and coping, and diagonal braces are carried from the center of these caps to the center of the cross brace timbers that carry the alters.

The dock is closed by a floating caisson. This is an iron vessel with sloping stem pieces that exactly fits the dock entrance. A heavy India rubber packing is carried around the entrance sills and abutments against which the caisson bears. No grooves are used, the working of the dock being thus greatly facilitated. Two sills are provided, an outer and inner one. This is to enable repairs of the inner or main sill to be attended to, as this is the one most used. The caisson can close the dock from either sill.

Very powerful pumping machinery is provided for emptying the dock. It consists of two centrifugal pumps of 42 in. diameter, driven by two vertical engines 28 in. diameter of cylinder by 24 in. stroke. Three Scotch steel boilers 13 ft. in diameter by 11 ft. long supply steam. The Southwark Foundry and Machine Co., of Philadelphia, supply the pumping plant. The pumps have a capacity of 80,000 gallons a minute, and can empty the dock in ninety minutes when no vessel is in it. If a ship is docked, the time required will be proportionately less. Open sluiceways are provided that are made in the concrete under the floor timbers on each side of the keelway. These lead to a drainage culvert and pumping well near the front of the dock on one side. The suction pipes run thence to the pumps. This supplies means for emptying the dock. The filling is done through the caisson. Culverts, with

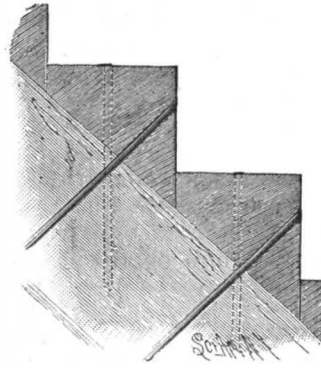

CROSS SECTION OF ALTERS.

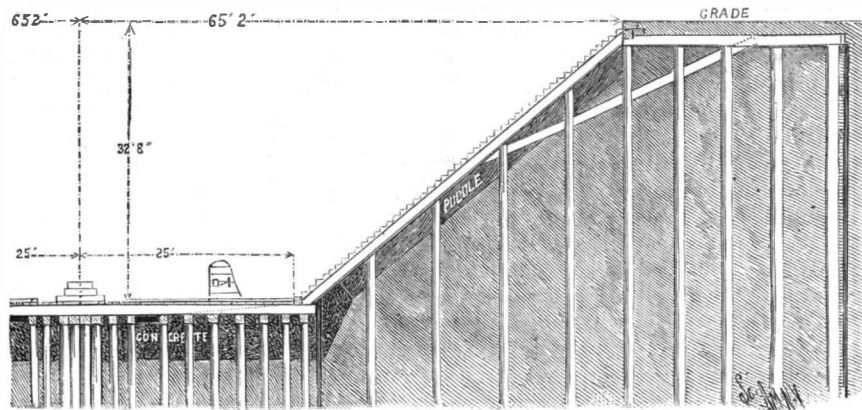

PLAN OF DOCK.

valves, run through its body transversely. Several flood gates 22 in. in diameter are provided, operated by hand wheels. Thus the filling can be extremely rapid.

The caisson is raised and lowered by pumping out or admitting water ballast, a small boiler, engine, and rotary pump being contained within it. The same engine works a capstan on its deck. Work was begun upon the dock about Dec. 16, 1887, possession of the ground having been acquired one month earlier. It is hoped that it will be completed by Feb. 1, 1890.

MR. CHAS. A. SCHIEREN, of the firm of Chas. A. Schieren & Co., has been appointed one of the committee for the International Exposition of 1892, to represent the leather belting industry.

Tomatoes.

The following is a summary of the results with tomatoes at the Cornell University Agricultural Station, I. P. Roberts director:

1. Frequent transplanting of the young plant, and good tillage, are necessary to best results in tomato culture.
2. Plants started under glass about ten weeks before transplanting into field gave fruits from a week to ten days earlier than those started two or three weeks later, while there was a much greater difference when the plants were started six weeks later. Productiveness was greatly increased by the early planting.
3. Liberal and even heavy manuring, during the present season, gave great increase in yield over no fertilizing, although the common notion is quite to the contrary. Heavy manuring does not appear, therefore, to produce vine at the expense of fruit.
4. The tests indicate that poor soil may tend to render fruits more angular.
5. Varieties of tomatoes run out, and ten years may perhaps be considered the average life of a variety.
6. The particular points at present in demand in tomatoes are these: Regularity in shape, solidity, large size, productiveness of plant.
7. The ideal tomato would probably conform closely to the following scale of points: Vigor of plant, 5; earliness, 10; color of fruit, 5; solidity of fruit, 20; shape of fruit, 20; size, 10; flavor, 5; cooking qualities, 5; productiveness, 20.
8. Solidity of fruit cannot be accurately measured either by weight or keeping qualities.
9. Cooking qualities appear to be largely individual rather than varietal characteristics.
10. The following varieties appear, from the season's work, to be among the best market tomatoes: Ignatum, Beauty, Mikado, Perfection, Favorite, Potato Leaf.
11. The following recent introductions appear to possess merits for market: Bay State, Atlantic, Brandywine, Jubilee, Matchless, and, perhaps, Lorillard, Prelude, and Salzer.
12. The following recent introductions are particularly valuable for amateur cultivation: Dwarf Champion, Lorillard, Peach, Prelude.

Electric Light Companies Everywhere.

A gas and electric light and power company is about to be established in Monson, Mass., a town of about 5,000 inhabitants, situated on the New London and Northern Railroad, four miles south of Palmer and fifteen miles east of Springfield.

George H. Newton will be president, and Thomas F. Robinson treasurer of the new company. The capital will be \$20,000, and the stock is to be taken by the business men of the place. Monson has long been noted for its academy of learning and for its extensive cotton and woolen factories. Ladies' woolen dress goods, men's straw hats, and ladies' straw bonnets are manufactured in large quantities, and it is here the celebrated granite quarries, worked very many years by the Flynt family, are located.

Japanese in China.

A remarkable phase in the recent industrial developments in China, says *Industries*, is the increasing number of Japanese employed in engineering works and manufactures. It is now almost twenty years since Japan made a start in modern industry, and not only did it start works under the superintendence of foreigners, but it commenced at the foundation, and instituted schools and colleges for the training of natives in the arts and sciences, and now, to a large extent, it is independent of foreign assistance in this respect, and almost all the works of which we hear so much are designed and manufactured by natives. In China there have been a few schools or colleges started with the same objects, but they have never been carried out with that thoroughness which is necessary for real success.

We understand that at present the Chinese government is on the outlook for several capable men to go to Peking as professors in different departments of pure and applied science. During the past year a considerable number have been engaged in similar capacities in the various arsenals, where schools for the training of young Chinese have been established. In the meantime, however, the supply of qualified Chinese is very limited, and some of the local governors, who have not been able to get over their dislike to Europeans, have engaged a considerable number of Japanese engineers, especially for mines and some departments of manufacture. In some cases even we understand that Japanese have been engaged as instructors in applied science, and, although able to understand the Chinese books, they cannot speak the language; and we have the curious spectacle of the younger Oriental nation teaching the older nation through the medium of the English language—a very odd phase in the history of civilization.

THE PROPOSED BRIDGE OVER THE ENGLISH CHANNEL.

The idea of connecting England with the Continent by a bridge is not new. It has from the beginning of this century occupied the minds of a great number of distinguished men, but the labors of M. Thome de Gamond particularly contributed to render the idea popular. The problem is at present clearly placed before the technical authorities of both countries.

The preliminary projects submitted by MM. H. Hersent, Schneider & Co., and Fowler & Baker, at the meeting of the Iron and Steel Institute, Paris, 1889, consist of separate reports relating respectively to the foundations for the piers to be erected in the sea and to the construction of the superstructure, as well as of a rational statement of the means for placing in position the foundations and spans.

The amount of metal and machinery to be provided for the construction of a bridge over the channel would represent an aggregate weight of about 1,000,000 tons. The assumption is that each country will have to supply one-half of this amount, which on either side would for a lengthy period give a powerful impulse to the development of national industry.

An approximate idea, as far as can be possibly formed by a rough calculation at first sight, assuming that the distribution of spans shown in the engraving is adopted, permits the following figures to be given with reasonable certainty: 380,000,000f. for masonry sup-

so that these joints may be at all times readily inspected to ascertain whether anything is out of order in each separate portion of the work.

The distance between the piers, fixed at 500 m. and 300 m. for the large spans, will not be less than 200 m. and 100 m. respectively for the small ones, and will, at all events, be sufficient to prevent their proving an obstacle to the free navigation of sailing vessels. As regards steamships, no such danger is to be apprehended, as the current, which would certainly become a little faster in the center of the open spans, would carry floating bodies, even disabled vessels, toward that part, and prevent their ever touching the bridge. It may, therefore, be reasonably admitted that, owing to these distances and dimensions, the piers would in no way modify the conditions of navigation in the channel, and would certainly not constitute an appreciable obstacle to navigation in general.

The metal columns are firmly placed upon the platforms of the supporting piers of masonry. They are of a distinctly cylindrical shape, and vary in height between 40 m. and 42.780 m., and on them will be placed the main girders of the bridge. There will thus be between the lower parts of the beams and the level of the sea at low water a free space varying in height between 61 m. and 63.780 m., which height at high water will be reduced to 54 m. and 56.780 m. respectively. This height is amply sufficient for the passage of vessels of whatsoever description or tonnage. By placing

The roadways are of the ordinary width of 1.50 m. between the axes and the rails. The latter will be set in grooves to obviate accidents. The floor, made of ribbed sheet iron, is to cover the bridge throughout its length, so as to make every part accessible to the men appointed for the supervision of the bridge. Between and outside the roadways pavements are provided for the men to stand on, and thus keep out of the way of passing trains. Upon the flooring it will be possible to establish "refuges," stations for the guards, signal boxes, switches, etc. All these arrangements may be multiplied according to the requirements of the traffic, and scattered over any convenient points and spans. On the piers lighthouses may be erected, to indicate obstacles to be avoided.

Boring Car Wheels.

In measuring the accuracy of a car wheel borer chuck, one is liable to believe the chuck to be correct when it is not so. The three jaws may be at equal distances from the center of the machine before the load is applied to the binding screws, but when a wheel is in position and the screws tightened up, the chucks may no longer be at equal distances. Therefore, it would seem that almost the only satisfactory way to determine the accuracy of the three-jawed chuck would be to place therein a wheel which had been turned to an exact circle and bored precisely true. The cutters then could be lowered into the axle fit,

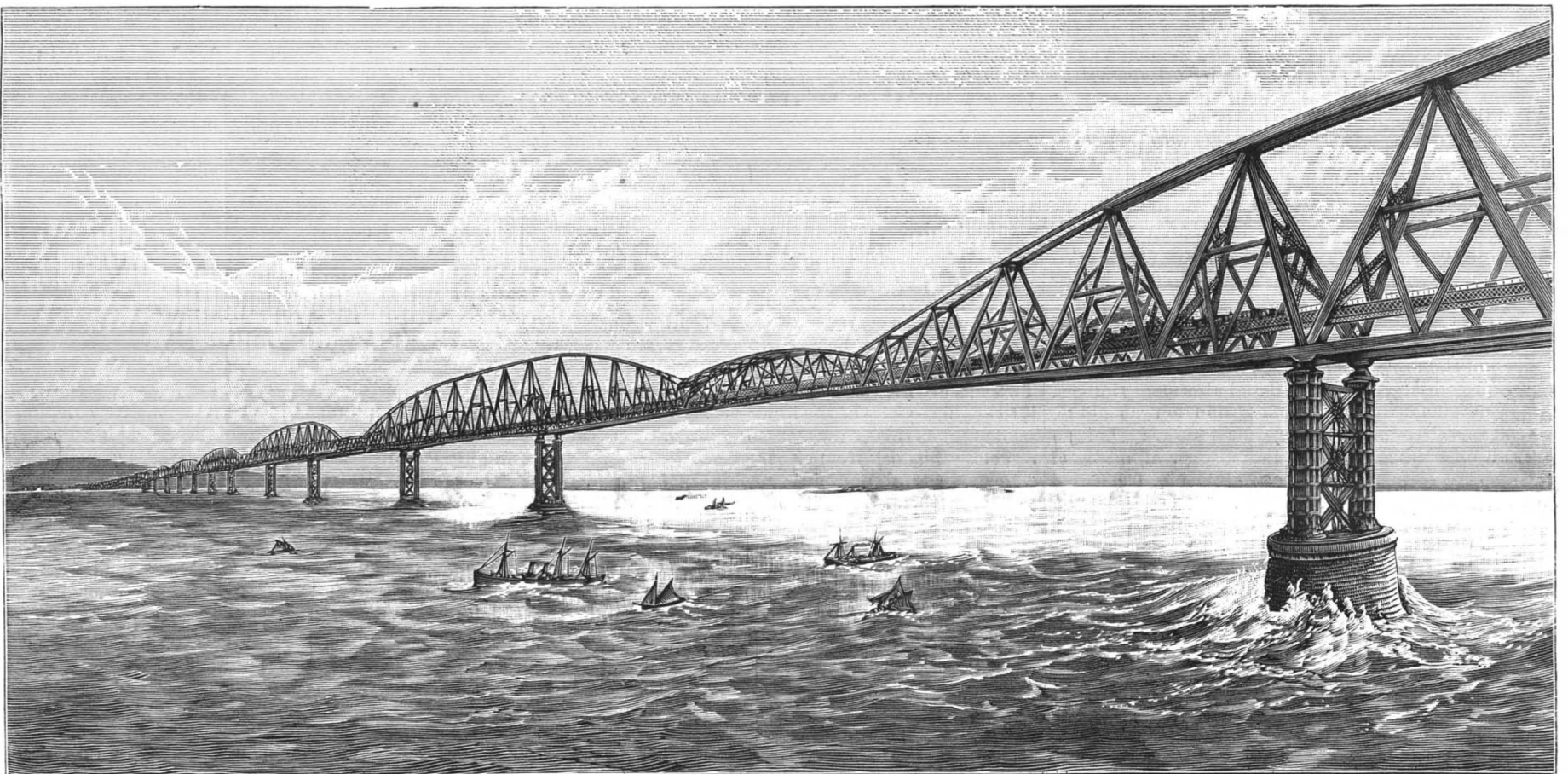

THE PROPOSED RAILWAY BRIDGE BETWEEN ENGLAND AND FRANCE.

ports and 480,000,000f. for the metallic superstructure, in all 860,000,000f., or £34,400,000, or \$172,000,000. The works for the tunnel and the railways of both countries would have to be planned later on in agreement with the companies whose lines would lead up to the bridge. The time required for the completion of the undertaking may be fixed at about ten years.

The situation which seems preferable for a bridge connecting England with the Continent is, as it were, suggested by nature herself, namely, by the line stretching over the shallowest parts of the channel, and connecting the shores where they are closest to each other. This line commences at a point near to Cape Grisnez and reaches the coast of England near Folkestone, passing over the banks of Colbart and Varne. This arrangement has been adopted in order to enable the existence of these two banks to be taken advantage of, so as to avoid working in great depths, and thereby to diminish the height of the piers to be erected. The ground is found to be sufficiently solid to support very extensive works.

The masonry will be built inside metal caissons similar to those used for ordinary bridge piers, and forced by compressed air down to the solid ground. These caissons, which will be surmounted by metal cases surrounding the masonry, will serve to float the piers until they touch the ground. This will enable the ground to be carefully cleaned, and promote the application of the concrete that is to be interposed between the masonry and the bottom, as will be explained further on. The caisson will, moreover, be surmounted by a movable dome, which will be removed when the upper part of the column is completed, so as to enable the masonry to be carefully finished with squared stones above the level of low water. Special arrangements will be made for joining the columns to the masonry,

the floor upon vertical cylindrical columns, the space above indicated, of a minimum height of 54 m., is kept throughout the whole width of the span.

In order to make the exigences of navigation agree as far as possible with the economical carrying out of the preparatory works, three different lengths of span have been proposed. No. 1, alternate spans of 300 m. and 500 m.; No. 2, alternate spans of 200 m. and 350 m.; No. 3, alternate spans of 100 m. and 250 m. The largest spans correspond to the greatest depths, the smallest to the most elevated parts of the sea bottom and to the parts near the shores. The system of girders to be employed is simple, unlatticed, trussed, so as to insure the distribution of all stresses. The secondary beams provided are intended to reduce the length of certain members, to prevent buckling of braced beams, and to give those employed as struts proportions suitable to the lengths concerned, whereby it becomes possible to leave the coefficient of compression, which would increase the weight, out of consideration.

The level of the permanent way is 72 m. above the low water level. This height might have been reduced by arranging the permanent way in the lower portion of the bridge, but in that case it would have been necessary to make the cross beams a great deal larger, and consequently heavier. By raising the permanent way, on the contrary, as it is proposed here to do, a marked economy is attainable, which will certainly not be absorbed by increased expenses involved by the necessity of erecting viaducts at both ends of the bridge. There will be a double set of rails, and the width of the flooring proper will be 8 m. The whole width of the bridge is variable. The greatest distance between the axes of the main girders is 25 m., such a space being necessary to insure the stability of the structure under the action of violent gusts of wind.

and by revolving the machine, measurements could be made as to its accuracy. Of late, much attention has been paid to grinding wheels, and it is not uncommon to see wheels on the tread of which considerable more material had been removed from one side than from the other; and while grinding wheels may not decrease their mileage when they are properly centered on the axle, yet if too much material is taken from one side, it is believed by several wheel makers that the mileage of the wheel may be considerably reduced. Grinding wheels will certainly make them true, but the knowledge of the possibilities of grinding should in nowise lead to a decrease in the care exercised in boring. The Chicago, Rock Island & Pacific has decided, after inspection of the mileage sheets of its car wheels, to do away with the process of grinding, having found that most wheels, when ground according to its system of grinding, are reduced in mileage about 20,000 miles. It is true that better chilled wheels are now being furnished railroad companies than ever before, but to obtain from them the mileage which their good qualities render possible, it is necessary that they be not only carefully centered, if they are not to be ground, but even more carefully centered if they are to be ground.—*Railroad Gazette.*

Natural Gas under Lake Erie.

A Chicago note, under date of October 21, says: "A vein of natural gas was opened recently by two workmen engaged in sinking the shaft at the intermediate caisson of the new city water tunnel, about two miles out in the lake. The gas was ignited by the lamps in the workmen's hats. There were five at work in the shaft, and all of them were more or less seriously burned. The injured workmen were finally rescued and sent ashore on a tugboat."

THE MILITARY BICYCLE.

The art of war is now borrowing from applied science all the resources that are at the latter's disposal, and there is nothing up to velocipedism that is not contributing to the service of the army. For a few years past, the Germans have been using the velocipede for the rapid carriage of dispatches, and, on this side of the Vosges, the French have not neglected to put to profit the advantages of an analogous service, a corps of velocipedists having been organized in the army. The type of apparatus adopted is the bicycle, such as is seen in Fig. 1, which shows a French army velocipedist, during the period of a campaign, commissioned with the quick carriage of an urgent dispatch.

The English have gone beyond such a use of the velocipede for dispatch sending, and have endeavored to use it for the carriage of ammunition. A very curious experiment of this kind was very recently made at London with a multicycle apparatus constructed by a Mr. Singer.

This truly curious apparatus is shown in Fig. 2. It consists of a series of bicycles, six in number, each carrying two men, and hauling a small vehicle loaded with ammunition. The bicycles are arranged in a single file, instead of being two or four abreast, thus much facilitating the operation of the apparatus and diminishing the surface of resistance to the wind. The speed on a good road varies from $9\frac{1}{2}$ to 15 miles per hour. The rubber tires are made in such a way as to secure them from being injured, even on roads that are somewhat stony.

The starting of the whole is under control of the man who sits in front. Recently the affair was run through one of the most frequented streets of London, and was found to turn easily in a much more circumscribed space than could have been done by an ordinary carriage, and to turn with great speed through the streets without any accident resulting. The body of men selected to maneuver this multicycle consists of experienced volunteers, who are capable, in addition, of going through all military evolutions.

Fig. 3 shows another phase in the use of the military bicycle as practiced in England, the illustration of which we borrow from the *Illustrated London News*.

A small body of cyclists, ten in number (two sections and a half-section), with officers and bugler, marching in usual order of half-sections—that is, by "twos"—are attacked by cavalry. At the word of command, "Halt!" "Prepare for cavalry!" "Form square!" each man dismounts; and the respective second half-section move up alongside their first half-section, so as to form a line of four men in front and rear, with a half-

section of two men between them. Each man then grasps his machine at the point of balance, and turns it outward, so that they form a square, with the men inside, each machine overlapping by a few inches those next to it.

The rifles are lifted out of their clips as the machines are lowered to the ground, and are then placed on the ground for a moment, while the machines are grasped with both hands by the framework and placed upside

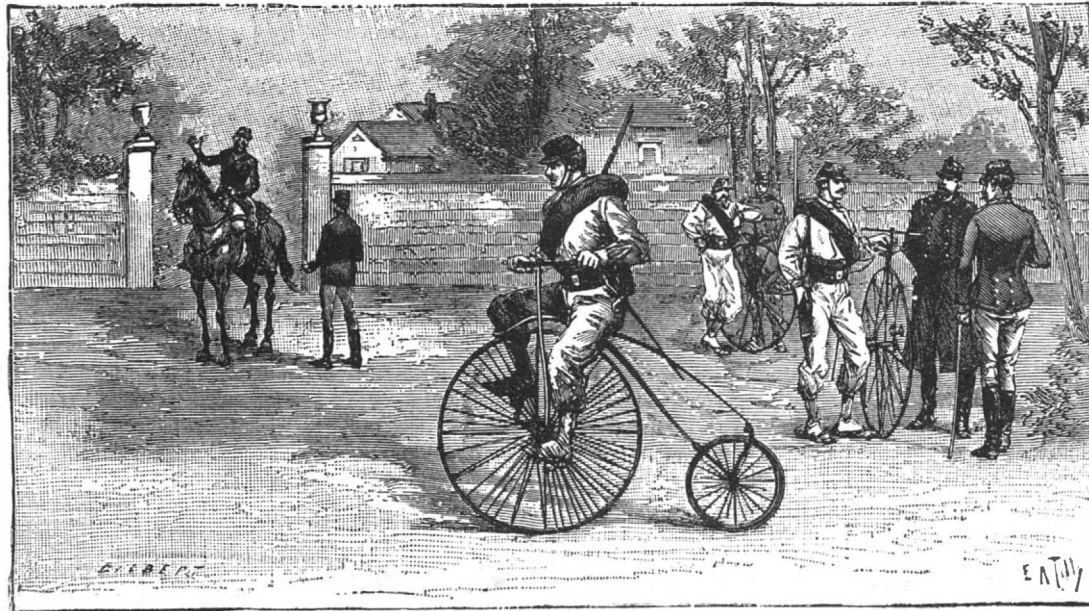

Fig. 1.—FRENCH MILITARY VELOCIPEDISTS.

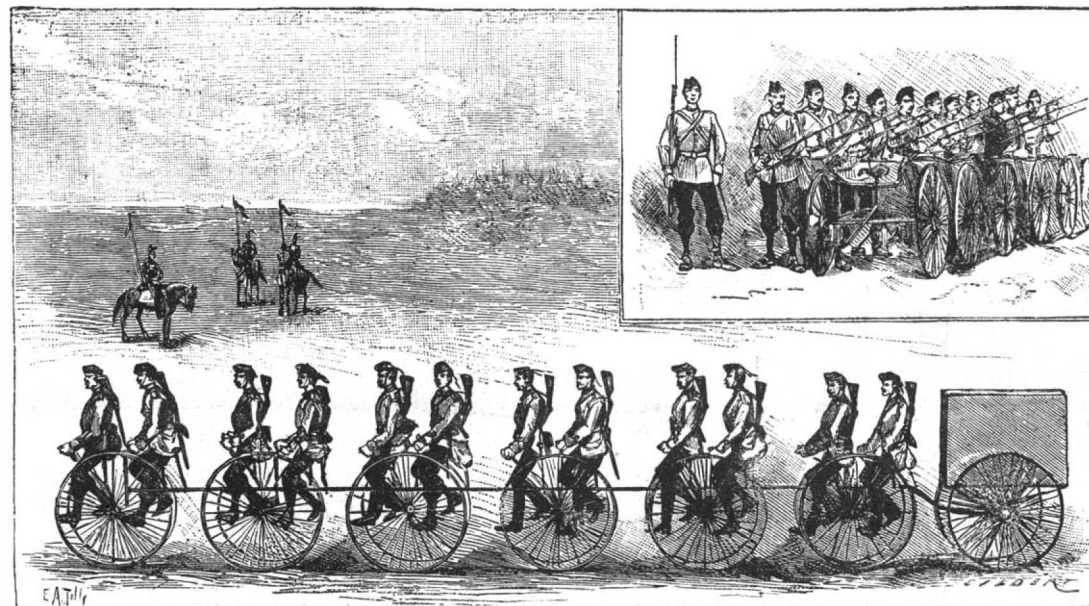

Fig. 2.—USE OF VELOCIPEDES IN THE ENGLISH ARMY.

down, so as to stand in a reversed position, resting on their handle bars and saddles.

Lastly, each man, as he lies or kneels down behind his machine, sets his wheels spinning round with a touch of his finger. Such a fence, apart from the *chevaux de frise* of bayonets behind it, forms an obstacle which few horses, if any, would face; and the men inside, in perfect security, can pick off the advancing horsemen with deadly effect.

The position, so far as mounted horsemen are concerned, is practically impregnable; while the infantry rifles, with which cyclists are armed, have great advantages, in accuracy and steadiness of aim, over the carbines of dismounted cavalry.

when tested never failed to find either water or mineral veins, the lodes having always been found exactly at the places indicated. The divining rod which he holds only moves in obedience to the muscular contractions of his hands, and a rod of any kind of wood or even of any material substance whatever can be used, provided it be a conductor of electricity. Rodwell usually walks with his hands tightly clasped before him, and as soon as he steps upon a mineral vein or water he is powerless to unclasp them until he moves away from the region of the lode or conduit. The lad is about 14 years of age. These statements by Dr. M'Clure have excited considerable comment in Yorkshire.

Japanese Lacquer.

From a paper on Japanese lacquer read lately by Mr. R. Hitchcock before the Chemical Society of Washington, D. C., we learn that Japanese lacquer is the product of a tree, the *Rhus vernicifera*, which grows throughout the main island of Japan. It attains a large size, the trunks sometimes measuring a meter in diameter. It is said the tree will live for forty years, but only comparatively young trees are valued

for the production of lacquer. Having yielded for several years they are cut down, the lacquer extracted from the branches, and young trees take their places. Mr. Hitchcock urges it should receive more attention than has hitherto been devoted to it by manufacturers in America. "It gives a surface to wood," he says, "much harder than our best copal varnish, without brittleness. It takes a polish not to be excelled, which lasts for centuries, as we may see in the old treasures of Japan. It is proof against boiling water, alcohol, and, indeed, it seems to be insoluble in every agent known. It is the best possible application for laboratory tables. I have a set of photographer's developing trays that have been in use for more than a year, and I find them excellent and cheap. In Japan it is used for many household articles." Unfortunately, lacquer poisoning from the fresh material is a serious danger. According to Rein, the poison is a volatile acid, and Mr. Hitchcock suggests that it might be removed by a heat that would leave the lacquer uninjured.

The Divining Rod.

Professor E. Ray Lankester, having recently expressed some doubts upon the alleged powers of a boy "water finder," who has been in the employ of the Grinton Mining Company, in the North of England, the chairman of the company, Dr. M'Clure, has replied to them, denying emphatically that the boy, whose name is Rodwell, is an impostor. He says that the lad

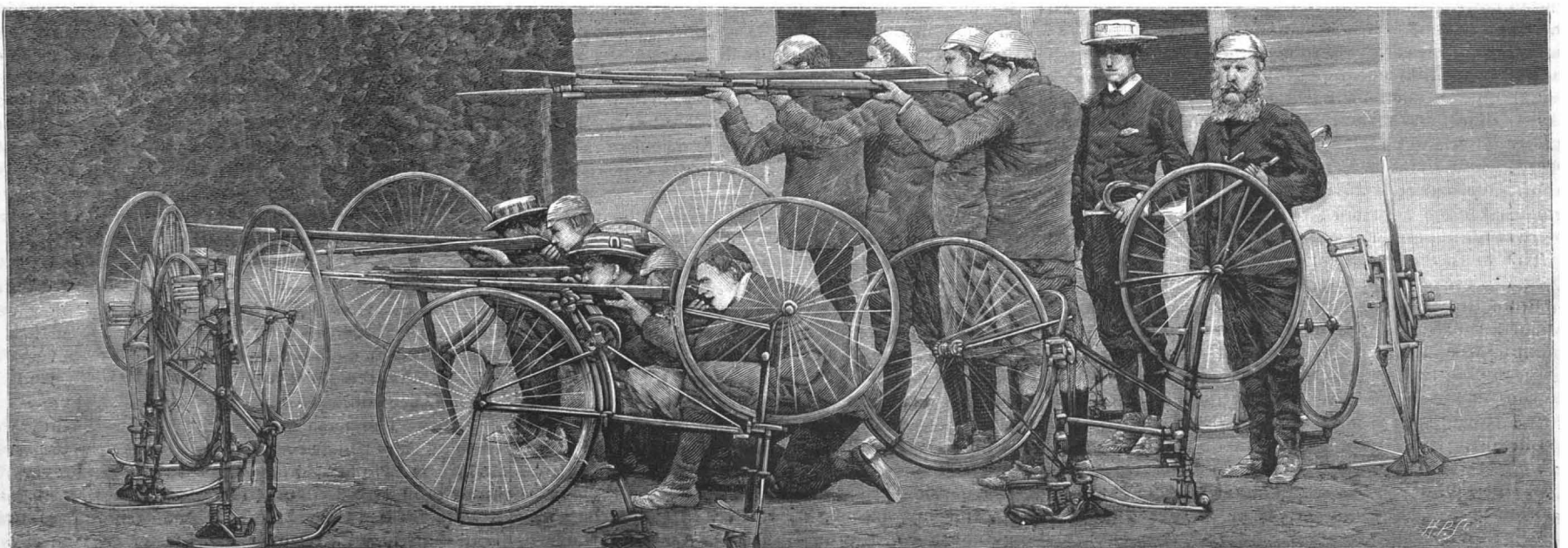

Fig. 3.—DRILL OF ENGLISH MILITARY BICYCLISTS.

THE HOOP SNAKE.

BY NICOLAS PIKE.

The serpent has been through all the ages an object of terror to man and beast. It has been and still is an object of worship by many nations—noticeably so by some of the native tribes of Hindostan. The death rate is fearfully increased in that country by bites from venomous snakes, and often whole families are bitten and the reptile goes free, because they fear to kill even an evil deity, as they look upon a cobra or other deadly reptile. Happily the missionaries and the heavy rewards offered by the British government for snake heads are breaking up some of this terrible creed. Even here a snake remains only a mysterious and repugnant reptile to the generality of mankind. Wisdom and subtlety, grace and ugliness, cunning and treachery, and a host of other qualities have been attributed to serpents, yet with two exceptions (the rattler and copperhead), like a good many people, they are not as bad as they seem.

It appears strange that at this late day the wildest superstitions are still extant with regard to reptile life, not only with the uncultured Indians, whose traditions are rich in serpent lore, but among most intelligent white men. There is one reason that may account partly for it. Nine out of ten people who meet a snake either kill it or run from it. In the latter case, fear not only lends wings to their feet, but to their imagination also. A harmless three-foot garter snake is magnified to six or seven feet at least, with hissing and venom thrown in. Now, if a little trouble were taken to watch some of the habits of the harmless snakes, they would soon lay aside their erroneous ideas.

There has been considerable written about the hoop or hoople snake, as the country people call it. It is firmly believed that it rolls over the plains of Long Island and elsewhere, and if you doubted it, they would think, if they did not say it, you were a booby. Students in the field (who ought to know better), farmers, and others, all men of intelligence and ordinary veracity, positively aver they have seen the snake roll often, and I do not doubt they believe it.

I will give one story to show how far credulity can go. A letter was received at the Smithsonian Institution, Washington, accompanied with an affidavit by a clergyman of the truthfulness of himself and a Mr. Laine, of Whittaker, N. C. The following is the gist of the story: "When in the suburbs of the town, Mr. Laine heard a noise behind him, and on looking round saw a hoop or horned snake three or four feet distant, rolling as he came on, with his tail in his mouth. When within striking distance, it disengaged the tail, struck at him, but missed its aim, when it stretched itself full length on the ground. A second attack was made, when Mr. Laine killed it, and he found the rear portion, one-third of the snake, capable of erection, firm and horn-like, all of which condition except $2\frac{1}{2}$ inches of the tail disappeared after death!" Other stories speak of their striking trees with their horny tails and poisoning them!

While shooting at Pondquogue, I had a very intelligent man as a companion, who told me positively that he had often seen the milk snake roll, and all I could say to the contrary was of no avail. I could recite a dozen more such instances, did space allow. My own first acquaintance with this snake was over forty years ago, during a pedestrian tour round Long Island with a friend. While encamped on the Comac hills, we sauntered out one morning, gun in hand, pot hunting. As we descended a slope, a large snake started almost under my friend's feet, and he moved so rapidly forward, I had difficulty in checking his career with No. 8 shot. We had been warned to be very careful of these snakes, but we were both familiar with reptiles, and were studying and collecting them fearlessly.

This was a fine specimen of the milk snake, or *Ophibolus doliatatus triangulus*, and as I was standing in an oblique direction from my friend and near the snake, I had an excellent opportunity of seeing its movements, rapid as they were. It darted from us in a succession of looping movements of the body, similar to those made by the measuring or geometrical worm in walking. This peculiar mode of progression is not confined to the milk snake, but the bull or pine snake (*Pityophis melanoleucus*) and the queen snake, or *O. getulus*, both have it. The apparent gyrating motion is caused by the lightning-like rapidity with which the reptile goes over the ground, that confuses the eye and renders the whole thing an optical illusion.

Three years ago I was hunting in a swamp, when I

met a German who was in a great state of fright. He was cutting rushes for chairs, when he said he saw a great snake come rolling toward him, and he had cut it in two with his sickle. I went to the spot he indicated, and found a four-foot female milk snake. To show how easily such mistakes are made, I will state that this man had never heard of a rolling snake, yet he spoke of it as such quite confidently from what he had seen, and doubtless it did appear so to him.

I disturbed a milk snake once near Farmingdale, when it raised its head, elevated the body into what appeared to be a circle, but was in reality an elongated loop, and vanished down the slope. Had I not known its habits of progression, I should have believed in its rolling, so perfect was the delusion. Some time ago I had one of these creatures in confinement a whole winter. A favorite position was to raise one or two long loops and rest the head on one of them, the little bright eyes taking in everything that moved near it (see plate). Sometimes it raised only one loop, twisting its tail round the neck in most intricate folds and hiding its head, where it remained for days thus fast asleep.

Any one who has studied the anatomy of a serpent knows that it is impossible for it to gyrate in a perfect circle, still less could it roll with its tail in its mouth. It is difficult to understand the propelling power in these creatures without some knowledge of their organization. To look at a dead snake casually, it appears as if nature had somewhat neglected the Ophidians, and yet in truth she has provided a wonderful apparatus for giving them celerity in eluding danger, catching their live prey, climbing, swimming, or walking, hardly found in other animals.

I will give some idea of the mechanism employed, by quoting here and there from the old naturalist, P. M. Roget: "The solution of the enigma is partly solved

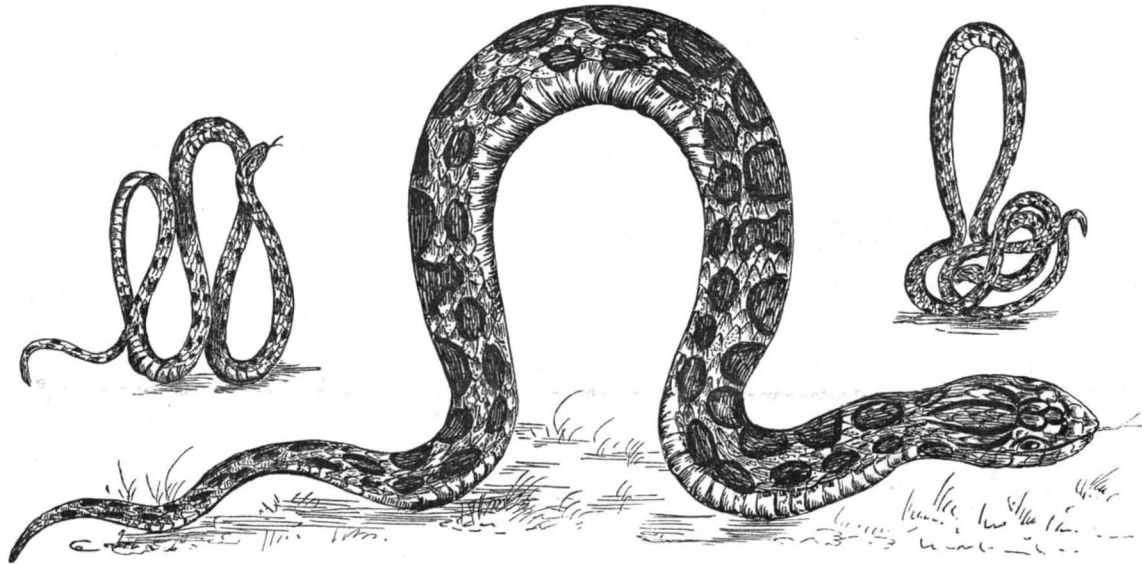

THE HOOP SNAKE (OPHIBOLUS DOLIATUS TRIANGULUS).

by the structure of the skin, covered with numerous scales, and partly in the peculiar conformation of the ribs. The edges of the scales form rough projections, which are directed backward, so as to catch the surfaces of the bodies to which they are applied and to prevent any retrograde movement. Every scale is connected with a particular set of muscular fibers capable of raising or depressing it, so that in this way it is connected into a kind of toe, and thus the body rests on the ground by numerous fixed points of support."

It would be out of place here to explain the whole form of the vertebra; suffice it to say that it admits of its assuming any degree and variety of curvature. Even this is not all—all the ribs play into concave protuberances of the vertebra. To quote further from the same author:

"Each rib terminates in a slender cartilage, tapering to a point, which rests for its whole length upon the upper surface of one of the broad scuta or broad scales on the under side of the body. These scuta are also moved by short muscles, and may be compared to hoofs; while the ribs may be considered as performing the office of legs. The ribs move in pairs, and the scutum under each pair being carried along with it in all its motions, and laying hold of the ground by its projecting ledge, becomes a fixed point for the advance of the body. The serpent advances by a creeping, vermicular motion—in fact, a succession of short steps; but its progress is accelerated by the curvatures into which it throws its body. Where expedition is needed, the body can be raised in one great arch, of which the extremities touch the ground. When in fear, or to escape danger, they coil themselves into a spiral by contracting the muscles of the body first on one side, then on the other, till it is propelled as if by the release and unwinding of a powerful spring with an impulse that raises it to some height from the ground and projects it to a considerable distance."

Now, if my unscientific readers will note the above rough outline of the organization of a serpent, they will see how impossible it would be for a snake to make itself into a circle, especially with its tail in its mouth.

This would effectually stop progression, as all flexibility would be arrested, on which the creature depends for its marvelous speed. This superstition is on a par with the violent hissing of snakes and their poisonous tongues. The latter delicate organ is thrust out quivering when the snake is in fear, or actuated by curiosity (of which they have a large share) to touch any near object, and is constantly used on its food. I have often seen my snakes in confinement test the food offered by the tongue, and it was accepted or rejected by the result. As to hissing, very few snakes make any noise at all, and then it is more of a puffing, blowing, or whistling noise, and mostly noticeable during the breeding season.

I should like to touch on one point connected with snakes that should be impressed on every farmer in relation to the milk and other harmless snakes. It is a pity they are being so indiscriminately slaughtered. As the birds destroy insect life, snakes are the persevering hunters of rodents, beetles and their larvæ, etc. The farmers have already found out that by the destruction of insectivorous birds insect pests have increased, to the detriment of their crops. So it is that the same policy with regard to the harmless snakes is giving the rats and mice full sway in the harvest fields.

I will terminate with a story a farmer told me. He said there was an old snake on their farm that year by year made its appearance among the sheaves of corn and soon cleared them of vermin effectually. His father would not have the creature molested, and it came and went at pleasure. Farmers, kill all your rattlers and copperheads, but spare the harmless ones—it will pay you to do it.

The Brush Electric Company Sells Out.

The recent purchase, by the Thomson-Houston Company, of the property and franchises of the Brush Electric Company, of Cleveland, was a transaction altogether unexpected in electrical circles. Financially, it is the most important operation which has taken place in the electric lighting business since the era of combination and consolidation set in. The Brush company was the oldest one in the field. It has been managed from the outset with unflagging energy, and for the most part with uncommon commercial sagacity, and, as a natural consequence, has been eminently prosperous and successful. The Thomson-Houston company has certainly paid a long price for the property, but as the purchase brings under one control almost the whole of

the arc lighting business of the United States, and at the same time disposes of a rival which was beginning to be troublesome in the direction of incandescent lighting and electric railroading, it is a question whether, after all, the bargain may not prove to have been a wise one.

The consolidation of electric companies by "heat and pressure," of which we have more than once spoken, has gone on with increasing rapidity during the past year. By far the greater number of the minor organizations have one by one fallen under the control either of the Thomson-Houston or the Westinghouse interests, until at the present moment the Edison company is about the only one of any prominence which has not succumbed to the inducements which one or the other of its stronger rivals have been able to offer. But as the Edison company does not pretend to do anything either in arc lighting or in incandescent lighting by alternate currents and converters, the bulk of the hard fighting, from this on, will necessarily be directly between the two powerful, well-equipped, and energetically managed organizations represented by Charles A. Coffin and George Westinghouse.

The absorption of the Brush company marks the beginning of what will doubtless prove to be the final and decisive struggle for supremacy in the electrical industries of this country.—*The Electrical Engineer*.

SOME statistics recently published by the city of Berlin show that London streets are on the whole the most crowded of any city in Europe. In 1878 it was ascertained that 43,014 people passed every 16 hours along the Leipziger Strasse in Berlin, and in 1883, 36,000 people crossed the Jannowitz Bridge every 18 hours. The most crowded bridge in Berlin is the Oramin, over which 80,000 people pass every 18 hours. In 1884, 58,743 passed along the Muntz Strasse every 16 hours, and 47,506 along the Getraudten Strasse. In London it is estimated 110,525 pedestrians pass over London Bridge daily; over Blackfriars, 79,198; Westminster, 44,460; Waterloo, 32,815. The most crowded thoroughfare in Europe is the Pont Neuf, Paris.

RECENTLY PATENTED INVENTIONS.

Engineering.

STEAM BOILER.—John M. Lachlan, New York City. This invention relates to marine and stationary boilers in which circulating pipes are employed in the fire box, and in the water space at the bottom of the boiler below the ash pit, the invention covering a novel construction and combination of parts whereby the circulation is made reliable and effective, and is placed under the easy and quick control of the engineer and fireman.

Railway Appliances.

CAR FLOOR.—Daniel H. Talbot, Sioux City, Iowa. This floor is made up of a series of parallel strips, united and held in position by bolts passed transversely through them, the strips being held a suitable distance apart by springs, the floor being elastic, and especially designed for freight and stock cars, being adapted for convenient application to any freight car.

RAIL TIE AND CLAMP.—Frederick Robert and Edward P. Eastwick, Jr., New York City. This tie is made of metal, and in connection therewith are employed two clamping blocks and two screw bolts, each bolt having screwed thereon an adjusting nut, whereby lateral movement of the rail sections may be readily obtained when desirable, the invention also providing means for removing the ties without affecting the rail sections.

CAR COUPLING.—Edward P. Eastwick, Jr., New York City. This coupler is of the vertical-plane hook type, and provides for a much greater bearing surface than usual of the revolvable knuckle, while the strain upon the drawhead caused by a buffing blow is reduced and taken up on the pin, which also answers for a locking pin.

CAR COUPLING.—Frederick Robert, New York City. This coupler is of the vertical-plane type, and the invention is designed to simplify the construction and do away with machine work, while providing large bearing surfaces for the knuckle, and novel means for taking up the buffing strain on the side of the drawhead, together with a locking device having a larger bearing surface than usual, and one in which the amount of lift of the pin is much reduced.

CAR COUPLING.—Charles H. Peard, Philadelphia, Pa. The drawhead of this coupling is formed with an aperture adapted to receive a coupling hook, while a standard to which a coupling hook is pivotally connected is mounted to slide in a second aperture in the drawhead, with means for operating the coupling hook, the device being designed for coupling freight cars of different heights without going between the cars.

Electrical.

DYNAMO-ELECTRIC MACHINE.—Heinrich Geisenhoner, Schenectady, N. Y. The frame of this machine has four loops in which are arranged the field magnet cores with their windings, the cores having polar extensions projecting on opposite sides of the frame, and two ring armatures revolving between the polar extensions on opposite sides of the machine, light or heavy currents of different intensities being obtained by changing the connections.

INCANDESCENT LAMP SOCKET.—Samuel Rodman, Jr., U. S. A. (at present stationed at Newport, R. I.) This invention provides a switch cylinder with a continuous spiral contact plate, there being spring tongues which bear against the cylinder and connections between the tongues and the light-producing agent, with other novel features, whereby the power or intensity of the light may be varied at will.

Mechanical.

SCREW MACHINE.—George Heyne, Offenbach-on-the-Main, Germany. This invention covers various combinations of devices for holding, feeding, turning, boring out, tapping, and cutting the rods or other pieces of metal from which the screws, nuts, and similar articles are to be made, the invention being an improvement on a former patented invention of the same inventor.

BOBBIN SPINDLE.—James Warrener, Fall River, Mass. This is a spindle or skewer with a bearing point partly of wood and partly of glass, having at its lower end a socket in which is a glass tip, the object being to lessen the amount of friction within the lower creel, while maintaining at all times a sufficient and uniform tension.

HEMMER FOR SEWING MACHINES.—Alice La Guayra Mayo, Great Falls, Montana Ter. This is an attachment for use with articles requiring a wider hem than the ordinary fell, the device affording means for turning a hem up to eight inches in width, and inserting a ribbon or tape within the hem, the hemmer also having a double gauge and being constructed in a simple and durable manner.

MEAL BOLT.—Conrad P. Steinmetz, Mitchell, Dakota Ter. This invention covers an improved shaking bolter in which a screen is secured to the shaking box of a feed mill, and receives its motion therefrom, this bolter being particularly adapted for bolting cornmeal, buckwheat, and other coarse grain.

Agricultural.

PLANTER.—Addison Leffel, Xenia, O. In this planter the wheels supporting the main frame have apertured felloes connected to hollow hubs, feed slides actuated by a cam plate being arranged in connection with the hub bores, while coverers are mounted to the rear of the wheels, the invention also covering other novel features of construction and arrangement of parts.

HARROW.—Joseph A. Beard, Liberty, Miss. This is a convertible harrow, designed to be

simple and strong in construction, which can be readily changed to and used as a side harrow, a V-harrow, an A-harrow, and a T-harrow, the invention covering various novel features and combinations of parts.

COTTON PICKER.—William F. Snowden, Brooklyn, N. Y. The frame of this picker has upper and lower lateral rotating rollers on which travels an endless belt, and having toothed aprons which dip into and between the plants to pick the cotton, there being a device for sweeping the cotton from the belt aprons into a chute.

SHEAF CARRIER.—Augustus Jewell, Dowagiac, Mich. This is an attachment for a self-binding harvester, and is so constructed that the bundles are dumped without hanging or catching in the arms of the carrier, the weight of the bundles assisting in dumping the load, while the dumping devices are effectively operated and locked by the foot of the driver.

Miscellaneous.

BALE TIE MACHINE.—Albert Henley, Lawrence, Kansas. This machine is specially designed to manufacture bale ties of wire for baling hay, straw, etc., and has a feeding mechanism and a cutter past which the wire extends, in combination with a longitudinally grooved rotary cylinder into which the wire is fed, with mechanism below the cylinder for successively operating covers to permit the wire to fall from the lowermost grooves.

AMALGAMATOR.—Nathan L. Raber, Corvallis, Oregon. This machine has a disintegrating feed wheel with upwardly projected ribs or flutes, the inner ends of which have inwardly facing cutting edges, a ring-like cover plate being secured to and revolving with the wheel, the chemicals for quickening the mercury being fed directly to the feed wheel, the motion of which effects an instantaneous and perfect distribution of the chemicals throughout the mercury space.

PIPE CARRIER.—Henry W. Petersen, Appleton, Wis. This carrier consists of an overhead track on which travels a truck supporting rods connected near their lower ends by a cross piece on which the pipe rests, being especially designed for conveniently holding pipe or other articles to be brazed or welded in a furnace fire and then running the pipe to an anvil or stake for welding, brazing, soldering, riveting, or putting the pipes together.

WATCH REGULATOR.—Frederick W. Schimmel, Wallace, Idaho Ter. The regulator has a curved screw and a nut with a circumferential groove near one end for receiving the end of a regulating lever, a star wheel being pivoted on the regulator, and there being other novel features, making a simple and effective device whereby the regulator may be positively moved a short distance, so that any owner of a watch may readily regulate it.

CHANGE DELIVERY APPARATUS.—David S. White, Huntley, Ill. A hopper is arranged under two pivotally mounted flanged plates or leaves, rods being connected to the leaves and a ring carried by the rods, the ring being arranged beneath the hopper, to provide for the quick and easy delivery of change and obviate the necessity of picking it up from the counter.

PENCIL SHARPENER.—Martin W. Walker, Sing Sing, N. Y. This sharpener has two sides inclined toward each other on which cutting edges are radially formed, an apertured bottom plate connecting the lower ends of the sides, and points being secured to their upper ends, to fasten the device to the frame of a slate.

PENCIL SHARPENING GAUGE.—George F. W. Holman, United States Navy, Torpedo Station, Newport, R. I. This is a gauge and point protector, to facilitate the true sharpening of pencils or crayons without soiling the hands or breaking the point, and consists of a tubular case cut away diagonally at one side to provide gauging faces for a cutter, an axially rotatable pencil clamp being fitted into the case.

BOOK REST.—John P. Findley, Blanchard, Pa. This is a rest designed for attachment to a chair or seat, for holding a book firmly, and by which the book may be readily adjusted to any desired position, the device being of simple and inexpensive construction.

ARTIFICIAL STONE.—Carolene M. Egbert, Westfield, Pa. This is a compound to be moulded in a molten state, and used for tombstones, vases, statues, etc., becoming very hard and durable, being made of thallium, glass, calamine, alum, white lead, white prepared chalk, etc., combined in specified proportions and in a manner described.

COMPOSITION FOR MOULDINGS.—Paul E. Gonon, New York City. Two patents have been issued to this inventor for a composition of matter which, when dried, is an imitation of wood or metal, or bronze, and whose density can readily be made equal to that of the different kinds of wood and metals, while the substance may be moulded or worked into ornamental articles or carved as wood is carved, and can be easily made fire proof.

MITER BOX.—William S. Herrington, San Francisco, Cal. This is a box readily adjustable to admit any sized stick, moulding, or board to be operated on, the box being one which can be quickly taken apart for convenience in carrying or packing, the invention covering various novel parts and details designed to provide a simple and durable construction.

BAKING DISH.—Mary H. Holcomb, Fargo, Dakota Ter. This dish is arranged to have attached to it an ornamental rim or cover provided with drapery, so that such dishes may be placed upon a handsomely arranged and well furnished table, and will present an attractive appearance.

PLATE OR DISH WASHER.—Thomas A. Pudan, Sacramento, Cal. A brush is mounted to be revolved in a casing by means of a horizontal shaft, the brush being held by a spring in contact with a plate held in the holder, the casing holding water prepared

for the cleaning and having a separate compartment for rinsing.

FOLDING BOX.—Charles Schwartz, Brooklyn, N. Y. This is an improved paper box, adapted to be folded flat for shipment or packing, and is made with folding walls adapted to be drawn up by a tape and locked to hold the box firmly in upright position, the end walls having flaps with locking tongues to enter slots in the outer end flaps, and the cover of the box being a part of the blank.

ICE TONGS.—John Sosenhamer, Hamilton, Pa. In these tongs the lower ends of the handles and the upper ends of the arms are pivoted together, the arms being then pivoted to the handles at points inside their individual pivotal points, whereby a slight movement of the handles gives a wide movement of the arms, and increases the rapidity and efficiency of their use.

HAND TRUCK.—Joseph P. Menard and Edward T. Weyman, Missoula, Montana Ter. This truck has a forwardly projecting arm, at the outer end of which is a horizontal clamp, a rod for operating the clamp, and a lever pivoted to the rod and truck, the device being designed especially for use in moving plow bottoms from place to place.

FIRE ESCAPE.—Lewis E. Morrison, Brooklyn, N. Y. This invention provides a fire escape designed to automatically prevent the too free run of the lowering rope, avoid severe shocks, and insure smooth and uninterrupted descent, while it can be made at but little expense, and is adapted to safely and smoothly lower any weight from any height.

MATTRESS.—Henry C. Farrell, New York City. The casing of this mattress has top and bottom aprons at the sides and ends, so laced that the top and bottom of the casing may be drawn taut, and affording provision whereby a circulation of air may be obtained through the mattress at all times.

BARREL COVER.—Charles F. Heins, Charleston, S. C. This cover consists of two parts pivoted for movement face to face, one part having a hoop adapted to fit a barrel top, with a spring normally closing the cover and a latch normally holding the cover open, the cover being one which may be simply laid on top of the barrel or be secured thereto by screws or nails.

SLED.—John D. Thomas, Petoskey, Mich. This is a sled adapted for propulsion by means of oar-like attachments, the oar-like levers each having on its outer end a foot furnished with spikes or prongs adapted to enable the operator to obtain a strong hold upon the ice or road bed over which the sleigh is propelled.

SHAFT SUPPORT.—John Vander Noot and Gerard W. Ryder, Gravesend, N. Y. Standards carrying hooks are arranged for connection with the forward axle, chains being connected to the shafts and arranged for connection with the hooks, whereby the shafts will be upheld and the draught animal relieved of the burden of their weight, and the shafts may also be held in elevated position when the vehicle is stored.

BRICK PALLET.—Robert J. Stuart, New Hamburg, N. Y. This is an improved pallet for supporting unburned bricks while being dried, and has vertical projections on its top against which the legs or supports of the superposed pallets rest, by means of which the several pallets may be arranged vertically on a car, and will be held from displacement by the swaying of the car.

TRAP.—Michael B. Nicholson, New York City. This trap has the usual U-shaped body, between the vertical members of which is a nearly closed chamber, having communication through small openings at the bottom and one upper edge with the main pipe, whereby, when the regular discharge is siphoned out, a discharge will be effected from the closed chamber sufficient to seal the trap.

STAVE BASKET.—John W. Alleger, Brooklyn, N. Y. The base of this basket is formed of a hoop or band of angle iron, the staves being attached to the vertical member of the hoop, while the bottom is forced down inside the staves upon the horizontal member of the hoop, the bottom being thus firmly supported and held, and making a basket adapted to withstand hard usage.

SKATE.—Thomas H. McQuown, Biggsville, Ill. The runner of this skate is made in two parts, the front part being pivoted on a bracket fastened to the front end of the rear runner and the front end of the sole plate section, the skate providing for readily passing over uneven ice, for making short curves, etc.

CANDLESTICK.—John P. Nettle, Newark, N. J. This candlestick has a weighted sliding frame with an opening for the candle, the frame descending as the candle is consumed, while the melted part of the candle is turned inward toward the wick, so that it will not run down the sides, and every particle of the candle is consumed.

VEGETABLE TOOL.—August Hirschel, Hackensack, N. J. This tool has a coring scoop portion, having a knife, and a flattened, spout-like portion having a transverse slot, and constructed to form a cutter on its back, making an implement especially adapted for peeling or scraping vegetables, with means for slicing and grating uses as well.

TRASH BURNING STOVE.—George C. Werner, Beatrice, Neb. This stove has an outer sheet metal case, within the walls of which, leaving a slight space, is held a perforated sheathing, there being upper and lower draught-controlling slides, and other novel features, providing for the ready removal of the stove body to dump the ashes and to refill the body with trash.

WASHING MACHINE.—William T. Venable, Christiansburg, Ky. This machine has a reciprocating shaft having stirring and agitating arms, and a double-acting spring buffer connected with and acting on the shaft, within a closed tank or receptacle, the mechanism being designed to operate quickly and easily without strain on the parts.

STRAP ATTACHMENT.—Walter Nelson, Wheeling, West Va. This is a strip of sheet metal with clamping lugs on its under side and guides on top adapted to receive the strap, a strip of flexible material being held on the under side by the lugs, making an improved strap for carrying shawls, satchels, etc., the attachment serving to conveniently hold the strap in place on the shoulder.

TRUNK HINGE.—Henry T. Helbing, Highland, N. Y. This invention covers a novel construction of the joint portion of the hinge and the hinge pin, whereby the lid or cover when thrown open, or nearly open, is held supported in such position by the hinge, and all other straps, cords, or jointed braces, are dispensed with.

TRIPOD.—John F. Godillot, New York City. The legs of this tripod may be readily detached from the table, and the sections disconnected and shoved together and fastened, to be carried or packed in small space, the table also taking little room, the tripod being light and more particularly designed for photographers and surveyors.

VEHICLE BRAKE.—John M. Hardin, Gest, Ky. This invention provides a brake adapted to be applied to the wheels and removed by the team, the brakes being applied when the team backs, as in going down hill, and removed when the team starts forward, means being provided whereby the brake may be held out of contact with the wheels when the vehicle is to be backed.

SCIENTIFIC AMERICAN

BUILDING EDITION.

NOVEMBER NUMBER.—(No. 49.)

TABLE OF CONTENTS.

1. Elegant plate in colors of a Gothic cottage to cost \$1,950. Perspective elevation, floor plans, and details.
2. Plate in colors showing a cottage to cost \$1,300. Floor plans, perspective elevation, and details.
3. A residence at South Orange, N. J., to cost from \$4,000 to \$6,000. Perspective and floor plans. F. W. Beall, architect, New York city.
4. The Cathedral of Seville. Fall of interior portions.
5. A residence for \$3,800 recently erected at Chester Hill, Mount Vernon, N. Y. Floor plans and perspective view.
6. Perspective view and floor plans of a colonial house erected at Larchmont Manor, N. Y., at a cost of \$8,500 complete.
7. A very attractive cottage for \$1,950, built at West New Rochelle, N. Y. W. A. Robinson, architect. Perspective and floor plans.
8. A cottage for \$2,000 at West New Rochelle, N. Y. Plans and perspective.
9. Drugstore architecture and decorations, with illustrations.
10. A colonial house recently erected at Chester Hill, Mount Vernon, N. Y., at a cost of \$4,000. Plans and perspective.
11. A very attractive residence at Chester Hill, Mt. Vernon, N. Y., from plans by H. S. Rapelye, architect, at a cost of \$6,500. Plans and perspective view.
12. Ornamental corner and band for ceiling decoration. By J. Barrett.
13. Christ Church, East Orange, N. J. R. H. Robertson, architect, New York.
14. A cottage for \$5,000, recently erected on Chester Hill, Mt. Vernon, N. Y. Plans and perspective view.
15. A residence for \$5,500 recently erected at Mt. Vernon, N. Y., from plans prepared by J. C. Brown, architect. Perspective view and floor plans.
16. New Post Office and United States Court House, Asheville, N. C.
17. Group of ornamental villas and grounds in Hanover, with ground plan.
18. Hall chimney piece, executed by Messrs. Walker & Sons, of London.
19. A pigeon house with view showing inside and ground plan.
20. Sewage works for large and small towns.
21. Miscellaneous Contents: Brown and red sandstone, of Connecticut.—Raising grape vines, with illustrations.—The best roses.—Practical men.—Scaffold bracket, with illustrations.—The first American marble quarry.—Wood carving and furniture.—Trees growing in towers.—Black granite.—Building in Colorado.—Improved road roller, illustrated.—Strength of stone masonry.—An interior enamel.—The "Amines" process of sewage purification.—Responsibilities of French architects.—The burning of Rome.—Antique carved furniture and woodwork.—Rock asphalt pavement.—The black birch (*Betula nigra*).—Drives and walks.—Transits for architects and carpenters, illustrated.—Ratchet auger handle, illustrated.—The roof.—Mammoth walnut burl.

The Scientific American Architects and Builders Edition is issued monthly. \$2.50 a year. Single copies, 25 cents. Forty large quarto pages, equal to about two hundred ordinary book pages; forming, practically, a large and splendid MAGAZINE OF ARCHITECTURE, richly adorned with elegant plates in colors and with fine engravings, illustrating the most interesting examples of Modern Architectural Construction and allied subjects.

The Fullness, Richness, Cheapness, and Convenience of this work have won for it the LARGEST CIRCULATION of any Architectural publication in the world. Sold by all newsdealers.

MUNN & CO., PUBLISHERS, 361 Broadway, New York.

Business and Personal.

The charge for Insertion under this head is One Dollar a line for each insertion; about eight words to a line.

All books, app., etc., cheap. School of Electricity, N.Y.

Wanted—First class mechanical draughtsmen. State particulars and salary expected.

Large woodworking establishment wants some specialty to manufacture. Facilities the best.

Patents for Sale—Extension fire ladder. U. S. 365,556; Canada 29,527.

Mill Property and Power for Sale. Situated at Rockaway, New Jersey, 38 miles from New York.

The rolling mill is nearly new, and complete with an equipment of rolls, furnaces, engines, turbine wheel, hammer, heater, etc.

For best hoisting engine. J. S. Mundy, Newark, N. J. Guild & Garrison, Brooklyn, N. Y.

For the latest improved diamond prospecting drills, address the M. C. Bullock Mfg. Co., Chicago, Ill.

Presses & Dies. Ferracute Mach. Co., Bridgeton, N. J. The Holly Manufacturing Co., of Lockport, N. Y.

Turk water motors at 12 Cortlandt St., New York. Screw machines, milling machines, and drill presses.

Billings' Double-acting Ratchet Drills. Drop Forgings. Bronze Forgings. Billings & Spencer Co., Hartford, Conn.

The Improved Hydraulic Jacks, Punches, and Tube Expanders. R. Dudgeon, 24 Columbia St., New York.

Send for new and complete catalogue of Scientific and other Books for sale by Munn & Co., 361 Broadway, New York.

Notes & Queries

HINTS TO CORRESPONDENTS.

Names and Address must accompany all letters, or no attention will be paid thereto. This is for our information, and not for publication.

References to former articles or answers should give date of paper and page or number of question.

Special Written Information on matters of personal rather than general interest cannot be expected without remuneration.

Scientific American Supplements referred to may be had at the office. Price 10 cents each.

Minerals sent for examination should be distinctly marked or labeled. (1530) G. T. R. asks for a recipe for a harmless compound which will stimulate the growth of hair on the face.

set up that brings about the result? Is it at the expense of the zinc by means of very slow oxidation? The other question is, are these articles perfectly safe for culinary purposes?

(1535) No Name asks whether electricity is a fluid or not. Two say it is, and three say it is not a fluid.

(1536) A. K. writes: 1. Here (Columbia, S. C.) we often seedrops of water like rainfall under the trees when the sun is shining and the sky is perfectly clear.

(1537) W. C. G. asks: 1. How can I make a good preparation, liquid or paste, for labeling tin or glass, which will not corrode the tin and will be cheap?

(1538) Dr. G. V. R. asks: In a wooden container separated into two equal parts by a thin metallic partition, each side to be nearly filled with water for the purpose of decomposition, by electrolysis—in such an apparatus, would the gases be given off at the immersed electrodes the same as if no partition existed between them?

(1539) B. G. asks for a receipt for ebonizing wood. A. Boil 40 parts gall nuts, 4 parts rasped logwood, 5 parts each of sulphate of iron and verdigris with water, strain through linen, and apply warm.

(1540) B. G. K.—Habitual divers in salt water often have inflammation of the eyes. The exposure such diving necessitates is not beneficial.

(1541) A. L. K.—See SCIENTIFIC AMERICAN SUPPLEMENT, No. 316, for the art of japanning.

(1542) H. C. B.—Zinc expands up to the melting point. A bar of hammered zinc 6 inches long will expand one one-hundredth of an inch in raising the temperature 100° Fah.

(1543) A. T.—There is no practical nor profitable way of removing copper and zinc from plumber's solder.

(1544) G. W. W. asks: What preparation is used to make quicksilver adhere to glass and metals? A. On mirrors an amalgam with tin is used.

(1545) J. S. asks: 1. Which magnet has the most power—artificial or natural? A. The artificial is far the most powerful.

(1546) W. B. R. asks: In what number is described how to make a flash light for photographic use? What material is flash cotton made of?

(1547) J. L. D. asks: 1. How can a vessel be filled with gas, without the use of water? A. By displacing the air.

(1548) G. S. asks whether bisulphide of carbon is dangerous to use, and what its properties are.

that is irrespirable and poisonous. 2. I would like to know whether turpentine mixed with charcoal is dangerous to use, and what its properties are?

(1549) W. R. C. asks: Is a combined lead and iron pipe more injurious to drinking water than one entirely lead?

(1550) W. S. asks: Is a ray of light a body or not? A. A ray of light is theoretically a series of ether waves.

(1551) C. E. J. writes: May I ask you to publish in your next weekly issue of your valuable paper as many of the most useful things for inventors to work on as you can think of?

(1552) E. J. R. says: Please let me know how to make a good concrete pavement.

(1553) Florida asks (1) method of preserving figs, as they are beginning to be sold in Northern markets.

(1554) A. B. C. writes: 1. Will you please tell me where I can get a very easy book on plain drawing, as I would like to learn, and have got no book.

(1555) J. H. S. asks (1) for method of making cyanide of copper solution for plating iron and other metals.

(1556) J. M. B. writes: In mixing 160 grains tannin, 1 ounce sulphate iron, and 1 pint water, a blue-black fluid is evolved, which is perfectly free from particles for about six hours.

(1557) E. G. S. writes: I load vessels monthly at New York with ice for the West Indies, and my consignees on there claim that no other but lake ice will suit or stand the climate.

lakes has also less air than moving streams, this likewise contributing to the density of lake ice. The difference between water of Lake George for instance and that of the Hudson River can be seen at a glance.

(1558) A. T. O. asks: 1. What is the lowest degree of cold that has been produced artificially, and by what means was it accomplished?

(1559) E. E. asks (1) if gasoline has been successfully used in gas engines as a motivepower. What would be the amount consumed in gallons per hour per indicated horse power?

(1560) E. G. C. asks how to make elastic gelatine moulds for electroplating.

(1561) F. M. W. asked in query 1452 about waterproof glue.

(1562) J. L. writes: I have tried a mixture of coal tar, glue, plaster of Paris and pitch to cover glassware with to make it appear like the bark of a tree after painting it the proper colors.

(1563) C. A. writes: How many feet of radiating surface to each 100 cubic feet of air space does one need in hot water heating?

(1564) J. H. K.—There is nothing equal to friction, with the leather slightly damp, for giving a high polish on the edge of fresh cut sole leather.

(1565) M. G. asks: 1. Is there a wax used in taking impressions of type for stereotyping which will stand the heat of melted type metal without melting, and if so, what is it?

(1566) J. A. M.—The "weather plant" described by Norvack is Abrus precatorius, of the order Leguminosae.

TO INVENTORS.

An experience of forty years and the preparation of more than one hundred thousand applications for patents at home and abroad, enable us to understand the laws and practice on both continents, and to possess unequalled facilities for procuring patents everywhere. A synopsis of the patent laws of the United States and all foreign countries may be had on application, and persons contemplating the securing of patents, either at home or abroad, are invited to write to this office for prices, which are low, in accordance with the times and our extensive facilities for conducting the business. Address MUNN & CO., office SCIENTIFIC AMERICAN, 361 Broadway New York.

INDEX OF INVENTIONS

For which Letters Patent of the United States were Granted

November 12, 1889,

AND EACH BEARING THAT DATE.

[See note at end of list about copies of these patents.]

Table listing inventions such as Adding machine, Address holder, Adjustable chair, Air brake, Alarm, Alcohol apparatus, Announcer, Armor plates, Awning, Axle bearings, Axle box, Bag, Baling press, Bandage, Banjo, Bar, Barrel cover, Basket, Bath mitten, Battery, Bed pan, Bed wardrobe, Beer wort, Bergh, Bells, Belt tightener, Bicycle, Billet conveyor, Billiard cues, Binder, Bit, Bituminous rock, Blind, Board, Bobbin spindle, Boiler, Bolt, Bolts or rivets, Boot, Bottle cover, Bottles, Box, Box ending mechanism, Box for jewelry, Box for retailers' use, Brake, Brake latch, Break scalper, Brick mould, Brick pallet, Bridge, Bridge gate, Bromides, Brush, Buckle, Building ventilator, Button, Calipers, Can capping machine, Candlestick, Capstan, Car brake, Car coupling, Car coupling, Car coupling, Car, automatic station indicator, Cars, floor for railway, Cars, sand box, Cars, sanding attachment, Carbon dioxide, Card setting machines, Cards, foundation for, Carpenters' use, Carpet stretcher, Carriage seats, Carriage wheel fender, Carrier, Cart, dumping, Cartridge loading machine, Case, Cash indicator and register, Cash indicator and register, Cash indicator and register, Casting armor plates, Casting ingots, Casting ribbed articles, Chain wheel casing, Chair, Check holder, Christmas tree ornament, Chuck, Chuck jaw, Churn.

Table listing inventions such as Churn power, Cider or wine press, Cigar cutter, Clamp, Clasp, Cleaner, Clevis, Clip, Clock or watch key, Closet, Clothes poulder, Coins and receiving therefor, Coking furnace, Collars, Collars, making apparel, Combing machines, Composing stands, Conduit for underground wires, Corrugated furnace, Cotton apparatus, Cotton picker, Coupling, Crates, Crocheting, Cushion, Cut-out, Cutter, Cutting machine, Dam, Deadcenters, Detector bar clip, Diaper, Die, Digging wells, Disinfecting, Display frame, Distillation of ammoniacal liquid, Distilling grease, Distilling pyrolygneous acid, Distilling wood, Drawer pull, Drill, Dust collector, Easel, Electric current indicator, Electric energy, Electric heater, Electric indicator, Electric indicator, Electric light post, Electric light support, Electric machine, Electric motor support, Electro-magnetic brake, Electroplated clamp, Elevator, Elevator bucket, Elevator case, Engine, Engine lubricator, Engine stopping mechanism, Engines, Evaporator, Exercising chair, Exhibiting machine, Exhibiting shoe laces, Extractor, Fan, Fan motor, Feed trough, Fence guard, Fence machine, Fence machine, Fence machine, Fences, Fender, File, File, letter or document, Fire engine, Fire extinguisher, Flask for making seamless sash weights, Flue cleaner, Frame, Fruit packing case, Fruit pitting machine, Furnace, Furnace, Game apparatus, Garment clasp, Garment support, Gas burners, Gas generator, Gas lighting, Gate, Gates, Gearing, Gears, Generator, Gimp preparing machine, Girder, Glimmer, Glassware, Grain binder, Grain binder, Grain meter, Grave protector, Grinding machine, Guard, Gun lock, Gun magazine, Hame, Handle, Harness loop, Harrow, Harrow, Churn power, Harvesters, Hatchet, Hay rack, Heater, Hinge, Hinge, Hinge, Hinge, Holder, Hook, Horse blanket, Horse blanket fastening, Horse detector, Horseshoe pad, Hose coupling, Hotel indicator, House, Hub and axle, Hydrant, Igniting and extinguishing apparatus, Indicator, Inking pad, Insect screen, Interlocking switch, Iron, Ironware, Ironing machines, Jack, Jewelry tool, Joint, Kettle, Key, Knife, Knitting machine, Knitting machine feeding device, Label attaching machine, Lacing hooks, Lamp, Lamp, Lamp, Lamp, Lamp, Lamp, Lamp, Letter opener, Lighting device, Liniment, Liniment, Lock, Lock, Locomotive journal box, Locomotive, Log dogging apparatus, Loom, Loom lever, Loom stopping mechanism, Loom temple, Loom temple, Looms, Low water alarm, Lubricator, Mallet, Map case, Match safe, Meal bolt, Medicine, Metal by electro-deposition, Metal, machine for galvanizing sheet or plate, Metal tie clamp, Metal, reducing, Meter, Mill races, Mould, Moulders, Monkey wrench, Mortising bit, Motor, Mower, Music box, Music leaf turner, Nail, Nail making, Nail strip, Necktie fastener, Nozzle holder, Nut lock, Nut lock, Nuts, Oil burning apparatus, Oil, oxidized linseed, Oil, thickening linseed, Ore concentrator, Ore separating and amalgamating machine, Ore separator, Overshoe attachment, Packing, Packing, Paper bag, Paper bags, Paper box machine, Paper box machine, Paper roll holder, Parcel carrier, Parer, Pegging machine, Pen, Pen, Permutation lock, Phonogram blank.

Table listing inventions such as Phonograph, Photographic films, Pile, Pile, Pipe and nut wrench, Pipe coupling, Pipe wrench, Piston, Planing machine, Planter, Planter, Planter, Planter, Post, Power, Press, Printing press, Printing form, Printing frames, Printing machines, Printing press, Printing press, Projectile, Propeller for boats, Propelling mechanism, Protector, Pruning implement, Pulley lubricator, Pulleys, Pump, Pump, Pumps, Puzzle, Rack, Railway cable, Railway, elevated, Railway rail clamp, Railway rail joint, Railway rails, Railway rails in chairs, Railway rails into flat plates, Railway rails, tie and clamp, Railway signal, Railway track, Railway vehicles, Railways, Rain conductor, Range finder, Rattan furniture, Reel, Reflector for locomotive headlights, Refractory composition, Refrigerator, Regenerative furnace, Rein button, Rein support, Rivet, Rivet making machine, Rivets, Rope or line holder, Rotary meter, Rule, Sad iron, Sand reel, Sash bar, Saw filing machine, Saw gauge, Saws, Scalloped ball cushion, Screen, Screw machine, Screw threading die, Seam pressing machine, Secondary battery, Seed drill, Selling device, Separator, Separator, Sewing machine, Sewing machine, Sewing machine, Sewing machine, Sewing machine, Signal, Skate, Snap hook, Snow plow, Soldering machine, Spinning mule, Spoke drawer, Spring, Sprinkler, Stair cases, Stamp, atmospheric, Stamping press, Steam boiler, Steam engine, Store service apparatus, Store service apparatus, Stove, Stove, Strap attachment, Straw cutter, Street or station indicator, Switch, Tank heater, Telescope objective, Telephone receiver holder, Temperature regulating apparatus, Terra cotta construction, Theatrical appliance, Phonograph, Photographic films, Pile, Pile, Pipe and nut wrench, Pipe coupling, Pipe wrench, Piston, Planing machine, Planter, Planter, Planter, Planter, Post, Power, Press, Printing press, Printing form, Printing frames, Printing machines, Printing press, Printing press, Projectile, Propeller for boats, Propelling mechanism, Protector, Pruning implement, Pulley lubricator, Pulleys, Pump, Pump, Pumps, Puzzle, Rack, Railway cable, Railway, elevated, Railway rail clamp, Railway rail joint, Railway rails, Railway rails in chairs, Railway rails into flat plates, Railway rails, tie and clamp, Railway signal, Railway track, Railway vehicles, Railways, Rain conductor, Range finder, Rattan furniture, Reel, Reflector for locomotive headlights, Refractory composition, Refrigerator, Regenerative furnace, Rein button, Rein support, Rivet, Rivet making machine, Rivets, Rope or line holder, Rotary meter, Rule, Sad iron, Sand reel, Sash bar, Saw filing machine, Saw gauge, Saws, Scalloped ball cushion, Screen, Screw machine, Screw threading die, Seam pressing machine, Secondary battery, Seed drill, Selling device, Separator, Separator, Sewing machine, Sewing machine, Sewing machine, Sewing machine, Sewing machine, Signal, Skate, Snap hook, Snow plow, Soldering machine, Spinning mule, Spoke drawer, Spring, Sprinkler, Stair cases, Stamp, atmospheric, Stamping press, Steam boiler, Steam engine, Store service apparatus, Store service apparatus, Stove, Stove, Strap attachment, Straw cutter, Street or station indicator, Switch, Tank heater, Telescope objective, Telephone receiver holder, Temperature regulating apparatus, Terra cotta construction, Theatrical appliance.

Table listing inventions such as Phonograph, Photographic films, Pile, Pile, Pipe and nut wrench, Pipe coupling, Pipe wrench, Piston, Planing machine, Planter, Planter, Planter, Planter, Post, Power, Press, Printing press, Printing form, Printing frames, Printing machines, Printing press, Printing press, Projectile, Propeller for boats, Propelling mechanism, Protector, Pruning implement, Pulley lubricator, Pulleys, Pump, Pump, Pumps, Puzzle, Rack, Railway cable, Railway, elevated, Railway rail clamp, Railway rail joint, Railway rails, Railway rails in chairs, Railway rails into flat plates, Railway rails, tie and clamp, Railway signal, Railway track, Railway vehicles, Railways, Rain conductor, Range finder, Rattan furniture, Reel, Reflector for locomotive headlights, Refractory composition, Refrigerator, Regenerative furnace, Rein button, Rein support, Rivet, Rivet making machine, Rivets, Rope or line holder, Rotary meter, Rule, Sad iron, Sand reel, Sash bar, Saw filing machine, Saw gauge, Saws, Scalloped ball cushion, Screen, Screw machine, Screw threading die, Seam pressing machine, Secondary battery, Seed drill, Selling device, Separator, Separator, Sewing machine, Sewing machine, Sewing machine, Sewing machine, Sewing machine, Signal, Skate, Snap hook, Snow plow, Soldering machine, Spinning mule, Spoke drawer, Spring, Sprinkler, Stair cases, Stamp, atmospheric, Stamping press, Steam boiler, Steam engine, Store service apparatus, Store service apparatus, Stove, Stove, Strap attachment, Straw cutter, Street or station indicator, Switch, Tank heater, Telescope objective, Telephone receiver holder, Temperature regulating apparatus, Terra cotta construction, Theatrical appliance, Phonogram blank, T. A. Edison.

Theatrical purposes, metallic corset for, W. B. Wood. 415,085

Therapeutic pad, G. H. Berns. 414,967

Thill coupling, Holtzman & Forsyth. 414,946

Thill coupling, D. D. Whitney. 415,180

Thrashing and separating machine, G. White. 414,738

Thrashing machines, tooth for the cylinders of, W. H. & J. Butterworth, Jr. 415,136

Tile, A. Metzner. 414,719

Tobacco, metallic fastener for, S. W. Reynolds. 414,845

Tooth crown, artificial, C. M. Richmond. 414,965

Toy, J. E. Scott. 415,176

Trap, M. B. Nicholson. 414,818

Trestle, coal stock, C. C. Rose. 414,725

Tricycle, F. White. 414,960

Trioxymethylene, R. Bohn. 415,088

Tripod, J. F. Goddillot. 414,903

Tripping machine, electro-mechanical, T. F. Gaynor. 414,695

Trough. See Feed trough.

Truck, cable car, J. Stephenson. 414,733

Truck for street railways, W. Joslin. 415,112

Truss, J. S. Blackburn. 415,087

Truss, V. Fischer. 414,880

Truss, J. O. Stephens. 415,078

Tunneling machine, R. Stanley. 414,893

Typewriter drop cabinet, Mighell & Gladwin. 414,933

Typewriters, etc., cabinet for, L. G. Billings. 414,968

Typewriting machine, A. B. Reid. 415,063

Typewriting machines, line feed mechanism for, T. Bigelow. 414,749

Umbrellas or parasols, detachable cover for, D. C. Fischei. 414,861

Urethral irrigator and dilator, F. J. Lindenschmidt. 414,981

Valve, pressure regulating, J. M. Foster. 414,975

Vegetables, tool for peeling or scraping, A. Hirschel. 414,908

Vehicle brake, J. M. Hardin. 414,904

Vehicle running gear, H. W. Frackmann. 414,893

Vehicle running gear, Sharpe & Carson. 414,892

Vehicle seat back, C. Bew. 415,017

Vehicle spring, E. Cook. 414,876

Vehicle wheel, Morsman & Higby. 415,117

Vehicle wheel, F. E. Southard. 414,782

Vehicles, spring platform for, F. G. Davis. 415,096

Vending apparatus, J. A. Williams. 414,786

Ventilating subways, I. L. Johnson. 415,110

Ventilator. See Building ventilator.

Violin tail piece, F. P. Snow. 414,923

Wagon jack, J. W. Clark. 414,678

Wagon seat fastener, Van Horn & Lathe. 414,957

Wash board, G. P. Fuller. 414,805

Washing machine, C. A. Japhet. 414,710

Washing machine, W. Slipper. 415,129

Washing machine, W. T. Venable. 414,928

Waiver, table, M. G. Toussley. 415,131

Watch bow fastener, F. L. Turner. 414,828

Watch case bow, E. C. Chappatte. 414,793

Watch case spring, J. D. Ewing. 414,802

Watch key, R. H. Franklin. 414,804

Watch, stem winding and setting, I. Goddard. 414,697

Watches, decorating, L. Favre. 415,100

Water closet service box, J. Crawford. 414,942

Water closet, siphon, W. Scott. 415,128

Water closet valve, J. Eckersley. 415,083

Water heater, G. W. Butterfield. 414,939

Weaving plain one-ply fabrics, A. D. Emery. 415,139, 415,144

Weaving seamless bags, E. D. Emery. 415,149

Weaving seamless bags, A. D. Emery. 415,155 to 415,157

Weaving seamless hip pockets, A. D. Emery. 415,158

Weaving seamless side pockets, A. D. Emery. 415,159

Weaving two-ply fabrics, A. D. Emery. 415,145

Weaving two-ply figured fabrics, A. D. Emery. 415,146

Wheel. See Vehicle wheel.

Wheel wrench, G. T. Hutchinson. 414,771

Whiffetree, C. H. & F. Kelly. 414,812

Wig holder, A. F. Godefroy. 415,104

Windlass, J. S. Baker. 415,036

Windlass, ship, E. H. Whitney. 415,080

Window, J. Barr. 414,965

Window, T. J. Daniel. 415,095

Window casement, metallic, H. Dugmore. 414,944

Wire, reel for winding, D. Grove. 414,809

Wood shaping machine guard, C. Rudolph et al. 415,127

Woven fabric, A. D. Emery. 415,138, 414,740 to 415,143

Woven figured fabric, two-ply, A. D. Emery. 415,147

Woven seamless bag, A. D. Emery. 415,145, 415,150, 415,153, 415,154

Woven seamless hip pocket, A. D. Emery. 415,152

Woven seamless side pockets, A. D. Emery. 415,151

Wrench. See Monkey wrench. Pipe wrench.

Pipe and nut wrench. Wheel wrench.

Wrench, V. J. McDonnell. 415,183

Yarns and textile fabrics, machine for fulling, washing, scouring, cleaning, and beetling, W. A. L. Hammersley. 414,810

DESIGNS.

Badge, E. M. Requa. 19,426

Belt clasp, W. L. Starr. 19,428

Bonnet, child's, E. J. Lynch. 19,424

Box, W. C. Estes. 19,417, 19,418

Dish, R. L. Johnson. 19,423

Mirrors, etc., back for hand, G. L. Crowell, Jr. 19,411

Stove, cooking, J. Dwyer. 19,413, 19,415

Stove, heating, J. Dwyer. 19,414, 19,416

Tableware, H. J. Smith. 19,427

Type, font of, G. F. Giesecke. 19,419, 19,420

Typewriters, etc., cabinet for, L. G. Billings. 19,410

Umbrella stand, H. W. Beeston. 19,408, 19,409

Upholstery and shade trimming, G. S. Hensel. 19,422

Upholstery or shade trimmings, G. S. Hensel. 19,421

Vehicle body, J. H. Osborne. 19,425

Wrenches, insertible jaw for, B. Donahue. 19,412

TRADE MARKS.

Bed springs, E. A. Jones. 17,189

Canned corn, beans, and succotash, H. C. Baxter. 17,184

Canned salmon, Northern Packing Company. 17,191

Canned vegetables, fruits, fish, oysters, and meats, H. C. Baxter. 17,185

Cigars, W. Straiton. 17,193

Eyeglass and spectacle frames, glasses for, Johnston Optical Co. 17,188

Gum, chewing, C. T. Heisel. 17,187

Petrolatum, Stenger & McKee. 17,192

Shingles and sawed lumber, Chaffe & Athens. 17,186

Stoves and ranges, heating and cooking, Michigan Stove Company. 17,190

A Printed copy of the specification and drawing of any patent in the foregoing list will be furnished from this office for 25 cents. In ordering please state the name and number of the patent desired, and remit to Munn & Co., 361 Broadway, New York.

Canadian Patents may now be obtained by the inventors for any of the inventions named in the foregoing list, provided they are simple, at a cost of \$40 each. If complicated, the cost will be a little more. For full instructions address Munn & Co., 361 Broadway, New York. Other foreign patents may also be obtained.

Advertisements.

Inside Page, each insertion - - - 75 cents a line.
Back Page, each insertion - - - \$1.00 a line.

The above are charges per azate line—about eight words per line. This notice shows the width of the line, and is set in advance. Engraving may be had at advertisements at the same rate per azate line, by measurement, as the letter press. Advertisements must be received at publication office as early as Thursday morning to appear in next issue.

USE ADAMANT WALL PLASTER

It is Hard, Dense, and Adhesive. Does not crack or peel. It is impervious to wind, water, and disease germs. It dries in a few hours. It can be applied in any kind of weather. It is in general use. Licenses granted for the mixing, using, and selling. Address **ADAMANT MFG. CO., 71 E. Genesee Street, Syracuse, N. Y.**

ICE-HOUSE AND REFRIGERATOR.
 Directions and Dimensions for construction, with one illustration of cold house for preserving fruit from season to season. The air is kept dry and pure throughout the year at a temperature of from 34° to 36°. Contained in SCIENTIFIC AMERICAN SUPPLEMENT, No. 616. Price 10 cents. To be had at this office and of all newsdealers.

“Star” Lathe Foot Lathe Swings 24x25 in. Screw Cutting Automatic Cross Feed, etc. **\$75**

LATHE Scroll Saws, Circular Saws, Lathes, Mortisars. Catalogue Free of all our Machinery.

Seneca Falls Mfg. Co., 695 Water St., Seneca Falls, N. Y.

SPECIAL NOTICE!
 We have just issued a Catalogue and Price List of Mining, Tunneling, and Quarrying Machinery. This catalogue will be mailed free to contractors, engineers, and to any one engaged or interested in rock excavation or compressed air. To all other persons it will be sent on receipt of 50 cents in postage stamps.
INGERSOLL-SERGEANT ROCK DRILL CO., 10 Park Place, New York.

ROCK DRILLS
AIR COMPRESSORS & GENERAL MACHINERY FOR MINING, TUNNELING, QUARRY & RAILROAD WORK
RAND DRILL CO. 23 PARK PLACE NEW YORK

ELECTRO MOTOR, SIMPLE, HOW TO MAKE. By G. M. Hopkins.—Description of a small electro motor devised and constructed with a view to assisting amateurs to make a motor which might be driven with advantage by a current derived from a battery, and which would have sufficient power to operate a foot lathe or any machine requiring not over one man power. With 11 figures. Contained in SCIENTIFIC AMERICAN SUPPLEMENT, No. 641. Price 10 cents. To be had at this office and from all newsdealers.

CATALOGUES FREE TO ANY ADDRESS
GEARS AND PARTS OF MODELS
GOODNOW & WIGHTMAN BOSTON

CABINET WOODS and VENEERS, FRET SAW or BRACKET WOODS, PLANED READY FOR USE
 Send stamp for catalogue.
HENRY T. BARTLETT, 200 LEWIS STREET, NEW YORK.

\$3 PRINTING PRESS
 For cards, labels, etc. Circular press, \$3. Size for small newspapers, Rotary jobber, 9x13, \$100. Do all your own printing and advertising. Full printed rules for type-setting, etc. Send 2 stamps for catalogue of presses, type, cards, etc., to factory. **KELSEY & CO., Meriden, Conn.**

THE GIRARD HYDRAULIC RAILWAY.
 Description of a railway which has excited much technical interest in Europe and America, and which threatens to revolutionize both the method and speed of traveling, when the expense of laying the line shall have been brought within moderate limits. With 8 figures. Contained in SCIENTIFIC AMERICAN SUPPLEMENT, No. 717. Price 10 cents. To be had at this office and from all newsdealers.

ASBESTOS
 MINERS & MANUFACTURERS. The ASBESTOS PACKING CO. 169 CONGRESS ST. BOSTON

TO BUSINESS MEN

The value of the SCIENTIFIC AMERICAN as an advertising medium cannot be overestimated. Its circulation is many times greater than that of any similar journal now published. It goes into all the States and Territories, and is read in all the principal libraries and reading rooms of the world. A business man wants something more than to see his advertisement in a printed newspaper. He wants circulation. This he has when he advertises in the SCIENTIFIC AMERICAN. And do not let the advertising agent influence you to substitute some other paper for the SCIENTIFIC AMERICAN, when selecting a list of publications in which you decide it is for your interest to advertise. This is frequently done, for the reason that the agent gets a larger commission from the papers having a small circulation than is allowed on the SCIENTIFIC AMERICAN.
 For rates see top of first column of this page, or address **MUNN & CO., Publishers, 361 Broadway, New York.**

PRESSES. 50 TO 500 TONS. By Hand or Power. For almost every purpose requiring pressure **BOOMER & BOSCHERT PRESS CO.** Send for Catalogue. 155 West Water Street, Syracuse, N. Y., U. S. A.

SEBASTIAN, MAY & CO'S
 Improved Screw Cutting
Foot & Power LATHES \$60

Drill Presses, Chucks, Drills, Dogs, and machinists' and amateurs' outfits. Lathes on trial. Catalogues mailed on application. **165 W. 2d St., Cincinnati, O.**

THE PHONOGRAPH.—A DETAILED description of the new and improved form of the phonograph just brought out by Edison. With 8 engravings. Contained in SCIENTIFIC AMERICAN SUPPLEMENT, No. 632. Price 10 cents. To be had at this office and from all newsdealers.

NICKEL AND ELECTRO-PLATING APPARATUS AND MATERIAL
HANSON, VAN WINKLE & CO. NEWARK, N. J. 92 LIBERTY ST. N. Y.

TYPEWRITERS

Send for New Illustrated Catalogue describing all Machines. Largest stock in America. New or Second-hand Typewriters of all makes. Machines Renowned in part of the country. Supplies in abundance. Prices the lowest.

NATIONAL TYPEWRITER EXCHANGE, 161 La Salle Street, Chicago, Ill.

VELOCITY OF ICE BOATS. A COLLECTION of interesting letters to the editor of the SCIENTIFIC AMERICAN on the question of the speed of ice boats, demonstrating how and why it is that these craft sail faster than the wind which propels them. Illustrated with 10 explanatory diagrams. Contained in SCIENTIFIC AMERICAN SUPPLEMENT, No. 214. Price 10 cents. To be had at this office and from all newsdealers.

Penberthy Automatic Injector.
 Cost less than others and do equal work. Lift 20 feet and work from head as well. Restart themselves and require no watching. Will lift through hot pipes, work from 25 to 150 lb. pressure. Parts removable without disconnecting, also interchangeable. Send for pamphlet. **Penberthy Injector Co., Detroit, Mich. Donegan & Swifts, 174 Fulton St., New York. Park & Lucy, San Francisco. L. M. Rumsey Mfg. Co., St. Louis.**

Scientific Book Catalogue
 RECENTLY PUBLISHED.
 Our new catalogue containing over 100 pages, including works on more than fifty different subjects. Will be mailed free to any address on application.
MUNN & CO., Publishers Scientific American, 361 Broadway, New York.

The Caligraph
 LIFE SHORT—WRITE LONG
 Address: The American Writing Machine Co., Hartford, Conn.; New York Office, 237 Broadway.

THE SOLAR SURFACE DURING THE Last Ten Years.—A paper by Rev. S. J. Perry, D.Sc., presenting the results of observations of the same made at Stonyhurst College Observatory, and touching upon the work of others in the same line of research. Contained in SCIENTIFIC AMERICAN SUPPLEMENT, No. 716. Price 10 cents. To be had at this office and from all newsdealers.

CLARK'S ALL IRON TRUCK WHEELS AND CASTERS,
 Noiseless Rubber-Tired Truck Wheels AND CASTERS, that save all wearing of floors. Also, COMPLETE TRUCKS. Catalogue free.
GEO. P. CLARK, Box L, Windsor Locks, Conn.

THE PENNA. DIAMOND DRILL & MFG. CO.
 BIRDSDORF, PA., Builders of High Class Steam Engines, Diamond Drilling and General Machinery. Flour Mill Rolls Ground and Grooved.

BARREL, KEG, Hogshead, AND STAVE MACHINERY.
 Over 50 varieties manufactured by **E. & B. HOLMES, BUFFALO, N. Y.**

SEWAGE WORKS FOR SMALL AND LARGE TOWNS.—Description of the sewage works of Kingston (England), in which the sewage is treated by the Native Guano Company's system. With 1 figure. Contained in SCIENTIFIC AMERICAN SUPPLEMENT, No. 716. Price 10 cents. To be had at this office and from all newsdealers.

BARNES' PAT. FOOT POWER MACHINERY.
 I feel so highly pleased with your Velocipede Foot Power with seat, that I wish to add my testimony to its superiority. I did not expect to like it, but having used it, I would have nothing else. It so greatly lessens the fatigue of using foot power, in fact, it may be said to be almost without fatigue, and is a steadier motion. I only wish I had known of it sooner. Send for catalogue. **W. F. & J. BARNES CO., 99 Ruby St., Rockford, Ill.**

COMPLETE STEAM PUMP ONLY SEVEN DOLLARS
 DEMAND THIS PUMP OF YOUR DEALER OR WRITE TO US FOR PRICES.
VAN DUZEN'S PATENT VAN DUZEN & TIFT. SOLE MAKERS CINCINNATI, O.

IMPROVED OIL & LIME LIGHT SETS OF MAGIC LANTERNS
 TEACH VIEWS WITH PRINTED LECTURES.
J. B. COLT & CO. 16 BEEKMAN ST. NEW YORK.

ARCHITECTURAL BOOKS.

Useful, Beautiful, and Cheap.

To any person about to erect a dwelling house or stable, either in the country or city, or any builder wishing to examine the latest and best plans for a church, school house, club house, or any other public building of high or low cost, should procure a complete set of the ARCHITECTS' AND BUILDERS' EDITION of the SCIENTIFIC AMERICAN.

The information these volumes contain renders the work almost indispensable to the architect and builder, and to persons about to build for themselves they will find the work suggestive and most useful. They contain colored plates of the elevation, plan, and detail drawings of almost every class of building, with specifications and approximate cost.

Seven bound volumes are now ready and may be obtained, by mail, direct from the publishers or from any newsdealer. Price, \$2.00 a volume. Stitched in paper covers. Subscription price, per annum, \$2.50. Address and remit to

MUNN & CO., Publishers, 361 Broadway, New York.

Lighting Well-Sinking Machinery.
 Makers of Hydraulic, Jetting, Revolving, Artesian, Mining, Diamond, Tools, Wells & Prospecting, Engines, Boilers, Wind Mills, Pumps, etc., SOLD ON TRIAL. An ENCYCLOPEDIA of 1,000 Engravings, Earth Strata, Classification, Determination of Minerals and Quality of Water. Gives Light, finds Gold. Mailed for 25 cts. Gas Book 25 cts. The American Well Works, AURORA, ILLS.

ICE-HOUSE AND COLD ROOM.—BY R. G. Hatfield. With directions for construction. Four engravings. Contained in SCIENTIFIC AMERICAN SUPPLEMENT, 59. Price 10 cents. To be had at this office and of all newsdealers.

OIL WELL SUPPLY CO. Ltd.
 91 & 92 WATER STREET, Pittsburgh, Pa.,
 Manufacturers of everything needed for **ARTESIAN WELLS** for either Gas, Oil, Water, or Mineral Tests, Boilers, Engines, Pipe, Cordage, Drilling Tools, etc. Illustrated catalogue, price lists and discount sheets on request.

THE MODERN ICE YACHT.—BY Geo. W. Polk. A new and valuable paper, containing full practical directions and specifications for the construction of the fastest and best kinds of Ice Yachts of the latest, most approved forms. Illustrated with engravings drawn to scale, showing the form, position, and arrangement of all the parts. Contained in SCIENTIFIC AMERICAN SUPPLEMENT, No. 624. Price 10 cents. To be had at this office and of all newsdealers.

ARTESIAN
 Wells, Oil and Gas Wells, drilled by contract to any depth, from 50 to 300 feet. We can manufacture and furnish everything required to drill and complete same. Portable Horse Power and Mounted Steam Drilling Machines for 100 to 600 ft. Send 6 cents for illustrated catalogue. Price A Artesian and Oil Well Supply Co., 80 Beaver Street, New York.

ICE-BOATS — THEIR CONSTRUCTION and management. With working drawings, details and directions in full. Four engravings, showing mode of construction. Views of the two fastest ice-sailing boats used on the Hudson river in winter. By H. A. Horsfall, M.E. Contained in SCIENTIFIC AMERICAN SUPPLEMENT, 1. The same number also contains the rules and regulations for the formation of ice-boat clubs, the sailing and management of ice-boats. Price 10 cents.

After Being on the Market Four Years The **"ACME" Still Leads.**
 Sizes One, Two, Three, and Four Horse Power. Arranged for either NATURAL GAS or Kerosene Oil fuel, as ordered. No extra insurance required on account of the oil fire. Send for catalogue giving full particulars and prices.
Rochester Machine Tool Works, Rochester, N. Y.

PILE DRIVING MACHINERY! Send for 1890 catalogue. Vulcan Iron Works, 80 N. Clinton St., Chicago.

The Stevens Portable Mills
 For CORN and FEED Grinding. Genuine French BUHR STONES **POWER CORN SHELLER.** Prices below the lowest.
A. W. STEVENS & SON, AUBURN, N. Y.
 Also Mfrs. of Threshers and Engines.

PATENTS!

MESSRS. MUNN & CO., in connection with the publication of the SCIENTIFIC AMERICAN, continue to examine improvements, and to act as Solicitors of Patents for Inventors.
 In this line of business they have had forty-one years' experience, and now have unequalled facilities for the preparation of Patent Drawings, Specifications, and the prosecution of Applications for Patents in the United States, Canada, and Foreign Countries. Messrs. Munn & Co. also attend to the preparation of Caveats, Copyrights for Books, Labels, Reissues, Assignments, and Reports on Infringements of Patents. All business intrusted to them is done with special care and promptness, on very reasonable terms.
 A pamphlet sent free of charge, on application, containing full information about Patents and how to procure them; directions concerning Labels, Copyrights, Designs, Patents, Appeals, Reissues, Infringements, Assignments, Rejected Cases. Hints on the Sale of Patents, etc.
 We also send, free of charge, a Synopsis of Foreign Patent Laws, showing the cost and method of securing patents in all the principal countries of the world.
MUNN & CO., Solicitors of Patents, 361 Broadway, New York.
 BRANCH OFFICES.—No. 622 and 624 F Street, Pa. City Building, near 7th Street, Washington, D. C.

Founded by Mathew Carey, 1785.

HENRY CAREY BAIRD & CO. Industrial Publishers, Booksellers, and Importers, 810 Walnut St., Philadelphia, Pa., U. S. A.

THE Scientific American

ESTABLISHED 1846. The Most Popular Scientific Paper in the World. Only \$3.00 a Year, including Postage. Weekly. 52 Numbers a Year.

This widely circulated and splendidly illustrated paper is published weekly. Every number contains sixteen pages of useful information and a large number of original engravings of new inventions and discoveries.

Terms of Subscription.—One copy of the SCIENTIFIC AMERICAN will be sent for one year—52 numbers—postage prepaid, to any subscriber in the United States or Canada, on receipt of three dollars by the publishers; six months, \$1.50; three months, \$1.00.

Clubs.—Special rates for several names, and to Post Masters. Write for particulars. The safest way to remit is by Postal Order, Draft, or Express Money Order.

MUNN & CO., 361 Broadway, New York.

THE Scientific American Supplement.

This is a separate and distinct publication from THE SCIENTIFIC AMERICAN, but is uniform therewith in size, every number containing sixteen large pages full of engravings, many of which are taken from foreign papers, and accompanied with translated descriptions.

The most important Engineering Works, Mechanisms, and Manufactures at home and abroad are illustrated and described in the SUPPLEMENT.

Price for the SUPPLEMENT for the United States and Canada, \$5.00 a year, or one copy of the SCIENTIFIC AMERICAN and one copy of the SUPPLEMENT, both mailed for one year for \$7.00. Single copies 10 cents.

Building Edition.

THE SCIENTIFIC AMERICAN ARCHITECTS' AND BUILDERS' EDITION is issued monthly. \$2.50 a year. Single copies, 25 cents. Forty large quarto pages, equal to about two hundred ordinary book pages.

A special feature is the presentation in each number of a variety of the latest and best plans for private residences, city and country, including those of very moderate cost as well as the more expensive.

The elegance and cheapness of this magnificent work have won for it the Largest Circulation of any Architectural publication in the world.

MUNN & CO., Publishers, 361 Broadway, New York.

QUEEN & CO. MAGIC LANTERNS SCIOPTICONS STEREOPTICONS FIRST CLASS PROJECTING APPARATUS FOR SCHOOLS COLLEGES AND PUBLIC ENTERTAINMENTS

MADE WITH BOILING WATER.

EPPS'S GRATEFUL-COMFORTING COCOA MADE WITH BOILING MILK.

PERFECT NEWSPAPER FILE

The Koch Patent File, for preserving newspapers, Magazines, and pamphlets, has been recently improved and price reduced.

48c. RAZOR STEEL SPECIAL SAMPLE OFFER! MAHER & GROSS. This cut is exact size of our 65c. razor steel, 2 blade, warranted Knife. Our production, 900 doz. monthly. Price to new customers, for a while, postpaid, 48c., 5 for \$2.

HARRISON CONVEYOR! For Handling Grain, Coal, Sand, Clay, Tan Bark, Cinders, Ores, Seeds, &c. BORDEN, SELLECK & CO., Sole Manufacturers, Chicago, Ill.

REMINGTON STEEL TYPE for TYPEWRITERS, Stencils, Steel Stamps, Rubber and Metal Type Wheels. New York Stencil Works, Mfrs. 100 Nassau Street, New York.

THE KODAK Embodies the only system of continuous film photography. World-wide success. "You press the button. We do the rest." Or you can do it yourself! THE EASTMAN DRY PLATE AND FILM CO. Price \$25, loaded for 100 pictures. Reloading \$2. Send for Kodak Primer, free. ROCHESTER, N. Y.

STANDARD TYPEWRITER. Gold Medal—Paris Exposition, 1889. Wyckoff, Seamans & Benedict 327 BROADWAY, NEW YORK.

The CHANDLER WATER MOTOR as adapted for blowing ORGANS. Automatic, Noiseless. Send for Circulars. Howard Bros., Buffalo, N. Y.

MINERAL WOOL INTERESTING BOOK Upon Its Uses and peculiar properties, mailed with sample free Western Mineral Wool Co., CLEVELAND, OHIO.

JOHN F. SAUNDERS Successor to SAUNDERS, IVES & CO. IMPORTER OF DIAMONDS And other Precious Stones. 26 Maiden Lane, cor. Nassau St., New York.

USEFUL HINTS ON STEAM By E. E. Roberts. A book of over 80 pages. Full of information about the Engine and Boiler. Sent on receipt of 20 cents. W. Blitz, Publisher, 107 Liberty St., N. Y.

CELEBRATED SUTTON RING PACKING. POSITIVELY ANTI-FRICTION, SPECIALLY ENDORSED FOR HIGH SPEED ENGINES. PIONEER RUBBER PACKING. SEND FOR SAMPLE PACKAGE AND PARTICULARS TO ERIE RUBBER CO. ERIE PA. U.S.A.

THE BOOKWALTER CASTING CO. Are now fully prepared to furnish Steel Castings on short notice, of any size and pattern, made under the BOOKWALTER AND ROBERT PATENTS. Address THE BOOKWALTER CASTING CO., Springfield, Ohio.

CUTLER DESK. BEST IN THE WORLD. A CUTLER & SON, BUFFALO, N.Y., U.S.A.

MAGIC LANTERNS and STEREOPTICONS for Public Exhibitions and for Home Amusement. Views illustrating every subject. A very profitable business for a man with small capital. Best apparatus, new views, largest stock. 26 years practical experience. 170-p. catalogue free GEO. H. PIERCE, 140 S. 11th St., Philadelphia, Pa.

WATCHMAN'S Improved TIME DETECTOR with Safety Lock Attachment. Patented 1875-47-80-81. Beware of infringing imitations. This instrument is supplied with 12 keys for 12 stations. Invaluable for all concerns employing night watchmen. Send for circulars to K. IMHAUSER, P.O. Box 2875, 295 and 208 Broadway New York.

Perforated Electric Belting FOR SWIFT RUNNING MACHINERY. Write for Descriptive Catalogue to CHAS. A. SCHIEREN & CO. 45-51 FERRY ST., NEW YORK.

2nd MACHINERY Lists N. Y. Mach'y Depot, Bridge Store 16, Frankfort St., N. Y.

ASBESTOS Fire Felt Coverings, Packings, Saeathings, &c. The CHALMERS-SPENCE CO., Mfrs. 419-425 8th Street, East River, N. Y.

CRANK AND SCREW SHAFTS OF THE Mercantile Marine.—A paper by G. W. Manuel, discussing some of the causes of the breakage of marine engine shafting, and also some of the remedies that have tended to reduce the number of such accidents. Contained in SCIENTIFIC AMERICAN SUPPLEMENT, No. 717. Price 10 cents. To be had at this office and from all newsdealers.

LETTERS PATENT FOR INVENTIONS Why they are so often worthless; how to obtain valuable patents; how to avoid the losses and disappointments which befall most inventors and patentees. Price 25 cents. Postage stamps received. Address BROWN & BERRY & CO., Booksellers, 25 Union Street, BOSTON, MASS.

\$60 SALARY \$40 EXPENSES IN ADVANCE allowed each month. Steady employment at home or traveling. No soliciting. Duties delivering and making collections. No Postal Cards. Address with stamp, HAFER & CO., Piqua, O.

WEITMYER PATENT FURNACE. BOILERS OF EVERY DESCRIPTION. IDE AUTOMATIC ENGINES. Traction and Portable Engines. STEAM ROAD ROLLERS. Manufactured by FOUNDRY & MACHINE DEPT., Harrisburg, Pa., U. S. A.

PULLEYS, HANGERS, FRICTION CLUTCHES. 44 Park Place, N. Y. PROGRESS MACHINE WORKS, A. & F. BROWN.

NOW READY. Experimental Science, BY GEO. M. HOPKINS. 740 Pages. 680 Illustrations. PRICE, by mail, postpaid, . . . \$4.00. MUNN & CO., Publishers, Office of The Scientific American, 361 Broadway, New York.

This book treats of the various topics of Physics in a popular and practical way. It describes the apparatus in detail, and explains the experiments in full, so that teachers, students, and others interested in physics may personally make the apparatus and perform the experiments without difficulty.

- HEADS OF THE CHAPTERS. I. Properties of Bodies. II. Rest, Motion, and Force III. The Gyroscope. IV. Falling Bodies, Inclined Plane, The Pendulum. V. Molecular Actions. VI. Liquids. VII. Gases. VIII. Sound. IX. Experiments with the Scientific Top. X. Heat. XI. Light. XII. Polarized Light. XIII. Microscopy. XIV. The Telescope. XV. Photography. XVI. Magnetism. XVII. Frictional Electricity. XVIII. Dynamic Electricity. XIX. Electric Lighting. XX. Induction by Electric Currents. XXI. Telephone, Microphone, and Electrical Magic XXII. Lantern Projection. XXIII. Mechanical Operations.

Each chapter is full and complete. Under the head of Sound, an extended description of the new Phonograph is given, with directions for construction. The chapter on Polarized Light is superbly illustrated and contains many simple experiments explanatory of this difficult subject. The chapter on Photography is a manual of the art. Electricity in all branches is fully treated. The performance of the experiments in the chapter on Dynamic Electricity will give the reader a practical knowledge of electricity in its modern applications.

Send for Free Illustrated Circular and Table of Contents.

MUNN & CO., Publishers, 361 Broadway, New York.

Proposals for Crank-Shaft for U. S. S. Brooklyn, at Navy Yard, Norfolk, Va., Oct. 29, 1889.—Sealed proposals, endorsed "Proposals for Shaft, etc." to be opened November 26, 1889, will be received at the Bureau of Provisions and Clothing, Navy Department, Washington, D. C., until 12 o'clock noon, November 26, 1889, and publicly opened immediately thereafter, to furnish and deliver at the Navy Yard, Norfolk, Va., a Crank-shaft for the U. S. S. Brooklyn, within 20 days from date of contract. The weight of the shaft will be about 7,500 pounds. Bids will be received for its manufacture of either steel or iron. If of steel, the metal must be made by the open-hearth process, and must conform to specifications which, together with blank proposals, etc., will be furnished upon application to the Bureau. The bids decided by lot. The Department reserves the right to reject any or all bids not deemed advantageous to the Government. JAMES FULTON, Paymaster-General, U. S. Navy.

WANTED GENERAL AGENTS AND SALESMEN ON RAND, McNALLY & CO'S New Family Atlas of the World

INDEXED, 288 PAGES, SIZE OF PAGE, 11 x 14. RETAIL PRICE, \$3.50. Outfit consisting of complete copy of FAMILY ATLAS, Order Book, Circulars and everything necessary to start the work, sent prepaid to any agent on receipt of \$2.00. Remit at once for outfit and name, choice of territory, or send for circular and terms, free. Address, RAND, McNALLY & CO., - 323 BROADWAY, NEW YORK.

TOOL AGENTS WANTED in every SHOP in the United States. Send 10c for Catalogue, Stationery &c. THE FINEST OF MECHANICAL TOOLS A SPECIALTY. C. E. JAMES, 98 LAKE ST. CHICAGO.

The Scientific American PUBLICATIONS FOR 1890.

Table with 2 columns: Publication Name and Price. Includes Scientific American (weekly), Supplement (weekly), Export Edition (monthly), Architects and Builders Edition (monthly), and Supplement, and Architects and Builders Edition.

Advertisements.

Inside Page, each insertion . . . 25 cents a line. Back Page, each insertion . . . \$1.00 a line.

The above are charges per agate line—about eight words per line. This notice shows the width of the line, and is set in agate type. Engravings may head advertisements at the same rate per agate line, by measurement, as the letter press. Advertisements must be received at publication office as early as Thursday morning to appear in next issue.

THE ONLY PRACTICAL LOW-PRICED

\$15 TYPEWRITER

Catalogue free. Address Typewriter Department, POPE MFG. CO., Makers of Columbia Cycles, Boston, New York, Chicago.



What is more aggravating than leaky valves, whether in House, Office, or Factory? If you wish to avoid annoyance, INSIST on having Jenkins Bros. Valves. Accept no valves as Jenkins Bros. unless stamped with our "Trade Mark" like cut.

JENKINS BROS.
71 John Street, New York.
105 Milk Street, Boston.
21 North 5th Street, Phila.
54 Dearborn Street, Chicago.

SYRACUSE MALLEABLE IRON WORKS
W B BURNS PROPRIETOR

The Largest Passenger and Freight Elevator Works in the World

OTIS

Otis Brothers & Co., 38 Park Row, New York

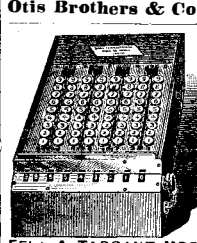

COMPTOMETER
ALL ARITHMETICAL PROBLEMS

Solved rapidly and accurately by using the Comptometer. Saves 40 per cent. of time. Entire relief from mental strain. Adapted to all commercial and scientific computations. Send for circular.

FELI & TARRANT MFG. CO., 52-56 Illinois St., Chicago.

SEND FOR CATALOGUE

COPPER TUBES
SHEET BRASS BRASSWIRE

175 177 LAKE ST. CHICAGO

WORKING MODELS and Experimental Machinery, metal or wood, made to order by MASON & RAYCH, successors to J. F. Werner, 62 Centre Street, New York.

CASTINGS SOFT AND STRONG, ROUGH OR FINISHED PULLEYS AND GEARING PATTERNS TO ORDER. ALLENTOWN FOUNDRY & MACHINE CO. 3rd & WALNUT STS. ALLENTOWN, PA.

THE AMERICAN BELL TELEPHONE CO.
95 MILK ST., BOSTON, MASS.

This Company owns the Letters Patent granted to Alexander Graham Bell, March 7th, 1876, No. 174,465, and January 30th, 1877, No. 186,787.

The transmission of Speech by all known forms of Electric Speaking Telephones infringes the right secured to this Company by the above patents, and renders each individual user of telephones not furnished by it or its licensees responsible for such unlawful use, and all the consequences thereof, and liable to suit therefor.

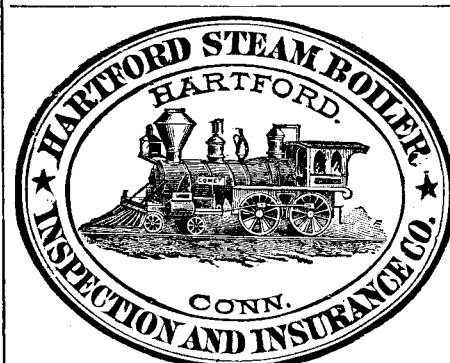

HARTFORD STEAM BOILER
INSPECTION AND INSURANCE CO. CONN.

ROSBY POP SAFETY VALVE WATER RELIEF VALVE IMPROVED STEAM GAGE STEAM ENGINE INDICATOR

Single Bell Chime Whistle, and all instruments used in connection with Steam, Air and Water.

Sole Agents for Clark's Lanen Fire Hose.
NEW YORK. LONDON.
GROSBY STEAM GAGE & VALVE CO. 98 Oliver St. Boston, Mass.

MALLEABLE AND FINE GRAY IRON ALSO STEEL CASTINGS FROM SPECIAL PATTERNS FINE TUNING JAPANNING AND FINISHING

THOMAS DEVLIN & CO. LEHIGH AVE. & AMERICAN ST. PHILA.

THE COPYING PAD.—HOW TO MAKE and how to use; with an engraving. Practical directions how to prepare the gelatine pad, and also the aniline ink by which the copies are made; how to apply the written letter to the pad; how to take off copies of the letter. Contained in SCIENTIFIC AMERICAN SUPPLEMENT, No. 438. Price 10 cents. For sale at this office and by all newsdealers in all parts of the country.

STEEL ALPHABETS. Brands, Seals, Steel Stencil Cutting Dies, Soap Moulds, Brass Stamps, etc.

J. M. STUTZMAN, 181 William St., N. Y.

CONTRACTORS WE MAKE THE LARGEST LINE OF ROAD GRADERS, SCRAPERS, PLOWNS FOR RR CONSTRUCTION THE WORLD OVER

AUSTIN MFG CO. NEW ERA Railroad Builder, Wagon Road Grader, Wagon Loader, and Ditching Machine. It will place in an embankment 100 cubic yards of earth in 10 hours at a cost of 1 1/4 to 2 cts. per yd.

WE MANUFACTURE THE LARGEST LINE OF WELLBORING TOOLS IN THE WORLD

CARPENTER ST. CARROLLAVE—CHICAGO ILL. U.S.A.

PRINTING INKS. THE "Scientific American" is printed with CHAS. ENEU JOHNSON & CO'S INK. Tenth and Lombard Sts., Phila., and 47 Rose St., opp. Duane St., N. Y.

THE NEW YORK LEDGER

"THE WHOLESOME EDUCATOR OF MILLIONS."

FREE TO NEW SUBSCRIBERS

If you are not convenient to a newsstand, send two dollars to the address below and the Ledger will be sent to you FREE till the first of January, 1890, and then continued for a whole year from that date.

THE LEADING WRITERS. CELEBRATED ARTISTS.

\$2 A YEAR SIXTEEN PAGES EVERY WEEK

SPECIAL FEATURES.

Herbert Ward, Stanley's Companion.

Herbert Ward, the companion of Stanley in his explorations in Africa, is the only white man connected with Stanley's African explorations who has ever returned alive from the "Dark Continent." Mr. Ward's articles running through eight numbers of the "Ledger" are of the most intensely interesting description, and cover five years of his adventures in Africa, and they will be illustrated by sketches made by Mr. Ward, and by the reproduction of photographs taken by him in Africa. These pictures will throw much light upon the manners and customs of the hitherto unknown cannibal tribes of Africa.

The Story of a Forsaken Inn, (A SERIAL STORY) By Anna Katharine Green.
Life in British America, By Rev. E. R. Young.

Being the adventures and experiences of Rev. E. R. Young, the celebrated missionary, and his wife during their residence in the Polar region twelve hundred miles north of St. Paul, in which Dr. Young narrates how he tamed and taught the native wild Indians of the Northwest; how he equipped himself for and how he made his perilous sledging and hazardous canoe trips when visiting all the Indian settlements within five hundred miles of his home.

Honorable Henry W. Grady

Contributes a series of six articles on the "Wonderful Development of the Industrial Pursuits of the New South."

American Cookery, (A SERIES OF ARTICLES) By Miss Parloa.

Giving the reasons why it is imperfect, and some ways by which it may be improved.

Nihilism in Russia, By Leo Hartmann, Nihilist.

Leo Hartmann, a fugitive from Russian authorities, has been connected with the most daring feats of the Russian Nihilists. Mr. Hartmann shows how the intelligent people of Russia are becoming Nihilists in consequence of the despotism of the form of government. A participant in plots to kill the Czar, such as the blowing up of the Winter Palace, he is able to give true information as to how this and other great schemes were accomplished. The situation in Russia is sufficient to increase the love of every true American for our form of government.

EXTRA SOUVENIR SUPPLEMENTS.

Among these beautifully illustrated four-page souvenirs, which will be sent free to every subscriber, will be a poem by

John Greenleaf Whittier, Illustrated by Howard Pyle.

Written for the "Ledger" by Mr. Whittier in his 82nd year. Another souvenir will be a beautifully illustrated poem written by

Honorable James Russell Lowell.

The Ledger will contain the best Serial and Short Stories, Historical and Biographical Sketches, Travels, Wit and Humor, and everything interesting to the Household.

Other Contributors for 1890 are:

- Mrs. Frances Hodgson Burnett.
- Mrs. Margaret Deland.
- Mrs. Florence Howe Hall.
- Mrs. Madeleine Vinton Dahlgren.
- Mrs. Harriet Prescott Spofford.
- Mrs. Emma Alice Brown.
- Mary Kyle Dallas.
- Marion Harland.
- Clara Whitridge.
- Judge Albion W. Tourgee.
- Marquise Lanza.

- Robert Louis Stevenson.
- Anna Shields.
- Josephine Pollard.
- Amy Randolph.
- Frank H. Converse.
- C. F. Holder.
- Dr. Felix L. Oswald.
- Rev. Emory J. Haynes.
- Julian Hawthorne.
- Prof. W. C. Kitchin.
- Robert Grant.

- M. W. Hazeltine.
- Thomas Dunn English.
- George F. Parsons.
- Col. Thomas W. Knox.
- Rev. Dr. John R. Paxton.
- Rev. Dr. James McCosh.
- Prof. S. M. Stevens.
- Prof. J. H. Comstock.
- James Parton.
- Rev. Dr. H. M. Field.
- Harold Frederic.

Subscription money can be sent at our risk by Post Office Money Order, Bank Check or Draft, or an Express Money Order. Send Six Cents for Sample Copy and Illustrated Calendar Announcement.

Address: **ROBERT BONNER'S SONS, 195 William Street, New York City.**

Wheeling is Better than Walking.



Victor Bicycles
Are Better than Any Others.
Catalogue Free.
Overman Wheel Co., Makers,
BOSTON, MASS.

SAWS Wanted 50,000 Sawyers and Lumbermen to send their full address for a copy of Emerson's Book of SAWS. We are first to introduce NATURAL GAS for heating and tempering SAWS with wonderful effect upon improving their quality and toughness, enabling us to reduce prices. Address EMERSON, SMITH & CO. (Ltd.), Beaver Falls, Pa.

2 to 40 H. P. **The MOTOR of 19th CENTURY.**
Can be used Any Place, to do Any Work and by Any One. No Boiler! No Fire! No Steam! No Ashes! No Gauges! No Engineer! A perfectly safe Motor for all places and purposes. Cost of operation about one cent an hour to each indicated horse power. For circulars, etc., address Charter Gas Engine Co. P. O. Box 148, Sterling, Ill.

PULLEYS. Cheapest, Lightest, and Best. Made by INVENTORS and others desiring new articles manufactured and introduced, address P. O. Box 86, Cleveland, O.

THE STANDARD
ASBESTOS CEMENT FELTING, FOR LAGGING LOCOMOTIVES, ETC. SECTIONAL PIPE COVERING. ASBESTO-SPONGE NON-CONDUCTING COVERINGS.



H.W. JOHNS ASBESTOS BOILER COVERINGS

PATENTED
INFRINGERS WILL BE PROSECUTED

Samples and Illustrated Pamphlet, "Steam Saving & Fire Proof Materials" FREE BY MAIL.

H.W. JOHNS MFG CO.
87 MAIDEN LANE
NEW YORK
CHICAGO
PHILADELPHIA
BOSTON