

# SCIENTIFIC AMERICAN

[Entered at the Post Office of New York, N. Y., as Second Class Matter.]

A WEEKLY JOURNAL OF PRACTICAL INFORMATION, ART, SCIENCE, MECHANICS, CHEMISTRY AND MANUFACTURES.

Vol. XLVIII.—No. 16.  
[NEW SERIES.]

NEW YORK, APRIL 21, 1883.

[\$3.20 per Annum.  
[POSTAGE PREPAID.]

## THE LEPANTO.

The Lepanto, launched on the 17th of March last, is sister ship to the Italia. The following description is partly abbreviated from one given in King's "War Ships," and copied from that work into Sir Thomas Brassey's work on the "British Navy." Side armor proper is dispensed with, the only plating being about 19 inches of steel-faced or steel armor on the barbette tower, and horizontal armor in the form of a deck, 4 feet 6 inches below the water line, consisting of 3 inches of steel. She carries four Armstrong breech-loading 100 ton guns in the center barbette tower, which is of peculiar shape, and consists of a wall inclosing two turntables placed diagonally, like the turrets of the Inflexible, and so arranged as to permit of all-round fire from the guns. The hull is of steel sheathed with wood, the lines fore and aft being very fine. It is constructed with the usual double bottom, 3 feet 3 inches between the skins amidships, and divided into numerous separate cells. Great strength is given to the structure by the bulkheads and decks. Two longitudinal water-tight bulkheads extend for the length of 254 feet 6 inches in the ship. These, together with the transverse bulkheads, divide the hull into fifty-three large compartments, which are again subdivided horizontally by four water-tight decks. The first of these is the armored deck above mentioned, which extends from stem to stern, and is incurvated at both extremities, meeting at the bow the extreme point of the ram, and thus adding material strength where most needed in the event of ramming an enemy.

Immediately above this armored or lowest deck is another, 6 feet above the water line, constructed of thin iron or steel and covered with wood. The side compartments between this and the lower deck just named, which are divided into water-tight cells, are to be filled with cork, as in the Inflexible. There is, however, this important difference, that whereas the last named ship has a long citadel in the middle of her length, protected by heavy armor, and relies upon cork only at her extremities, in the Italia the cork and water-tight cells afford the only means of preserving stability when the

sides are penetrated near the water line. The third or battery deck is 14 feet above the water line, and upon it are to be carried twelve guns of 6 inches caliber; and 7 feet 9 inches above this, and 25 feet above the water line, is the fourth or upper deck, supporting the casemate battery, 7 feet 6 inches in height, in which are to be placed the great guns in quadrantal shields at each extremity of the oval. The guns are to be fired *en barbette*, being supplied with ammunition from below the armored deck through armor-plated cylinders or shafts, of 9 feet inside diameter.

M. Dislère, in the *Revue Maritime*, gives further particulars as to the Italia and Lepanto. Each vessel is to be propelled by two screws of 19 feet diameter, each of them being worked by an engine of six cylinders. The power expected is 18,000 horses, giving, it is hoped, a speed of sixteen knots. The usual amount of coal is 1,500 tons, but 2,500 can be carried. At low speed the fires might be kept in for six months. The principal dimensions are as follows:

Length between perpendiculars .....	400 ft. 6 in.
Breadth of beam at water line .....	72 " 9 "
Breadth of beam at upper deck .....	65 " 6 "
Draught of water forward .....	25 " 6 "
Draught of water aft .....	30 " 6 "
Draught of water, mean .....	28 " 0 "
Area of immersed midship section .....	1,770 sq. ft.
Displacement at load draught .....	1,148 tons.
Length of armored tower on fore and aft line .....	88 ft. 6 in.
Breadth of armored tower across ship, extreme .....	72 " 6 "
Length of armored tower <i>per se</i> .....	96 " 0 "
Breadth of armored tower .....	52 " 9 "
Distance of stem from armored tower .....	170 " 0 "
Thickness of sides of tower, including armor .....	3 " 3 "
Thickness of iron armor on tower .....	1 " 7 "
Height of center of heavy guns above water line .....	32 " 8 "
Height of top of tower above water line .....	30 " 0 "
Height of upper deck above water line forward .....	25 " 0 "
Height of upper deck above water line aft .....	23 " 0 "
Height of upper deck above water line amidships .....	22 " 6 "
Height between upper deck and battery deck .....	7 " 9 "
Height between battery and second deck .....	7 " 9 "
Height between second and armored deck .....	7 " 6 "
Depth of lower deck below water line amidships at sides .....	5 " 6 "

Depth of hold under lower deck .....	21 ft. 0 in.
Extension of ram beyond forward perpendicular .....	6 " 4 "
Distance of point of ram below water line .....	8 " 6 "

### MOTIVE MACHINERY.

Number of engines .....	4
Number of cylinders .....	12
Number of propellers .....	2
Diameter of propellers .....	19 ft. 6 in.
Number of boilers .....	26
Number of furnaces—three to each boiler .....	78
Length of ship for and aft occupied by engines, coal, and boilers .....	250 ft.

The estimated weights of the hull, armor, etc., are approximately as follows:

Hull .....	5,000 tons.
Armor of armored deck .....	1,200 "
Citadel .....	900 "
Ammunition shafts .....	246 "
Chimneys .....	552 "
Total weight of armor .....	2,898 "
Teak backing .....	114 "

The boilers were designed and made by Messrs. Penn. The engines are two sets of the three-cylinder vertical inverted type, on each of the two screw propeller shafts, making twelve cylinders in all. Twelve of the boilers will be located in three groups aft of the engines, and fourteen in the three groups forward of the engines. The after boilers are placed sufficiently high above the keel to admit of the passage of the screw shafts under them. The engines are of the same type as have been supplied by Messrs. Penn to the Northampton and Agamemnon, the cylinders being of equal diameters, applied to cranks set at equal angles. The steam and exhaust valves are so arranged as to allow the engines to be worked either on the compound or non-compound system, as desired. We are indebted to the *Engineer* for the foregoing particulars, and to *La Ilustracion*, of Madrid, for our sketch.

THE capacity of pipes is as the square of their diameters. If you double the diameter of a pipe, you increase its capacity four times.

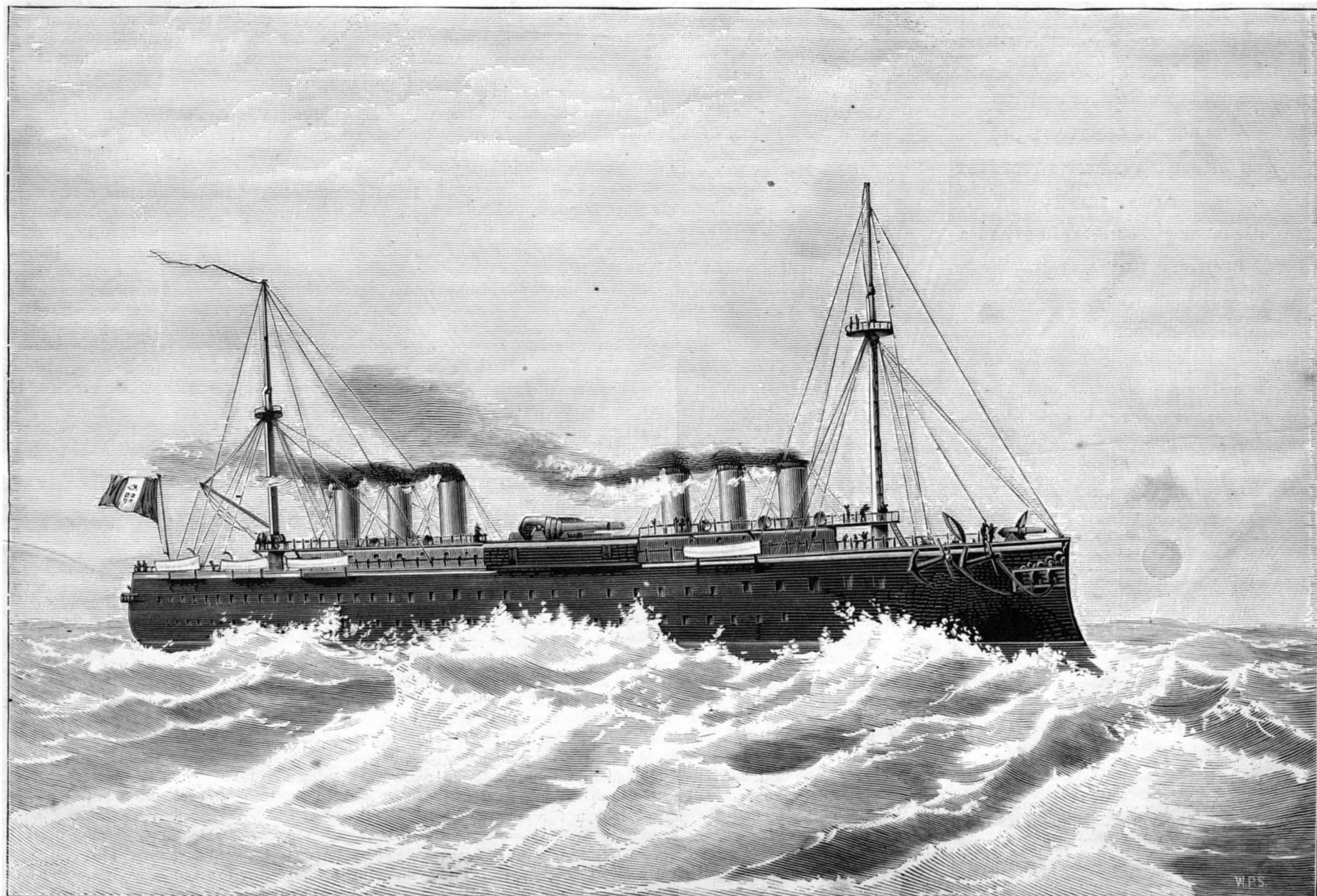

THE NEW ITALIAN SHIP OF WAR LEPANTO.

Scientific American.

ESTABLISHED 1845.

MUNN & CO., Editors and Proprietors.

PUBLISHED WEEKLY AT

No. 261 BROADWAY, NEW YORK.

O. D. MUNN.

A. E. BEACH.

TERMS FOR THE SCIENTIFIC AMERICAN.

One copy, one year postage included. \$3 20
One copy, six months postage included 1 60

Clubs.—One extra copy of THE SCIENTIFIC AMERICAN will be supplied gratis for every club of five subscribers at \$3.20 each; additional copies at same proportionate rate. Postage prepaid. Remit by postal order. Address

MUNN & CO., 261 Broadway, corner of Warren street, New York.

The Scientific American Supplement

is a distinct paper from the SCIENTIFIC AMERICAN. THE SUPPLEMENT is issued weekly. Every number contains 16 octavo pages, uniform in size with SCIENTIFIC AMERICAN. Terms of subscription for SUPPLEMENT, \$5 00 a year, postage paid, to subscribers Single copies, 10 cents. Sold by all news dealers throughout the country

Combined Rates.—The SCIENTIFIC AMERICAN and SUPPLEMENT will be sent for one year postage free, on receipt of seven dollars. Both papers to one address or different addresses as desired.

The safest way to remit is by draft, postal order, or registered letter. Address MUNN & CO., 261 Broadway, corner of Warren street, New York.

Scientific American Export Edition.

The SCIENTIFIC AMERICAN Export Edition is a large and splendid periodical, issued once a month. Each number contains about one hundred large quarto pages, profusely illustrated, embracing: (1.) Most of the plates and pages of the four preceding weekly issues of the SCIENTIFIC AMERICAN, with its splendid engravings and valuable information; (2.) Commercial, trade, and manufacturing announcements of leading houses. Terms for Export Edition, \$5.00 a year, sent prepaid to any part of the world. Single copies 50 cents. Manufacturers and others who desire to secure foreign trade may have large and handsomely displayed announcements published in this edition at a very moderate cost.

The SCIENTIFIC AMERICAN Export Edition has a large guaranteed circulation in all commercial places throughout the world. Address MUNN & CO., 261 Broadway, corner of Warren street, New York.

NEW YORK, SATURDAY, APRIL 21, 1883.

Contents.

(Illustrated articles are marked with an asterisk.)

Table listing various articles such as Agricultural inventions, Archaol. discov., Central Amer., Atmospheric rock perforator, Bakuol, illuminating oil, Bursting of armatures, Butter case, improved, Clock of Strassburg, the, Compressed air locomotive, a., Copeland's fire escape, Cost of stopping a train, Dried leaves as food, Economy in hops, Electrical street car, Electricity in printing presses, Electro pulverizer and amalgam, Elevator, improved, Exercise, the aim of, Fishing by electricity, Greenhalgh's lamp extinguisher, Hairy child, a., Hardening taps and dies, Incidents in a philoso. boyhood, Index of inventions, Insects and plants, Internal mite in fowls, Inventor of the telephone, Lamp extinguisher, new, Lepanto, Italian war ship, London fish exhibition, Loon, the, Machine for measuring fabrics, Manes' electro pulverizer, Manuf. of blue coloring matters, Mechanical inventions, New books and publications, Olson's sawing machine, Perpetual motion clocks, Peter Cooper, Pneumatic rock drill, improved, Printing positive from positive, Sawing machine, improved, Scientific American, usefulness, Steam engine, the, Street car, electrical, Talking one thousand miles, Telephone, first, description, Torpedo boats in collision, Traction wheel, War ship, Lepanto, Waste products utilized.

TABLE OF CONTENTS OF THE SCIENTIFIC AMERICAN SUPPLEMENT No. 381,

For the Week ending April 21, 1883.

Price 10 cents For sale by all newsdealers

Table listing contents of the supplement by section: I. ENGINEERING AND MECHANICS.—The Indus Railway Bridge. II. ELECTRICITY.—An Electric Alarm. III. CHEMISTRY AND METALLURGY.—Ice Under Low Pressure. IV. MEDICINE AND HYGIENE.—Alcohol in Health. V. TECHNOLOGY.—Thorough Washing and Effectual Fixation of Gelatine Negatives. VI. ARCHITECTURE.—The Palazzo Vendramin-Calergi, Venice. VII. AGRICULTURE AND HORTICULTURE.—The Chrysanthemum and its Culture. VIII. BIOGRAPHY.—Captain Eyre Massey Shaw, C.B. IX. MISCELLANEOUS.—Professor Huxley on Education. New Weights and Measures in Turkey.

PROGRESS OF ARCHÆOLOGICAL DISCOVERY IN CENTRAL AMERICA.

Of the fact of there being ruins of ancient cities, hitherto shrouded in mystery, scattered over that large tract of country which separates North from South America most persons are now aware. But their nature, age, or relation to the early history of the world has remained till quite recently a matter of which comparatively nothing has been known. It has, however, been for some time recognized that among the most interesting of these archæological remains are some in Yucatan—a peninsula dividing the Gulf of Mexico from that of Honduras, situated between 17° 30' and 21° 50' N. lat., and at no great distance from Cuba.

Determined to explore these ruins and learn the lessons they might teach, a scientific investigator, Dr. Augustus Le Plongeon, accompanied by his wife, set out on a mission of discovery to Yucatan in August, 1873, from which he recently returned. Ten years previous to this he had determined the task of writing an account of prehistoric America, and having dedicated himself to this work, had found, after having explored the ruins of antiquity found in Peru and Bolivia since 1862, that in Yucatan were situated the most valuable materials for such work; and a residence of nine years, constantly engaged in explorations both of a super- and subterranean nature, has made him familiar with many of the Yucatan ruins. Both he and his wife being skillful practical amateur photographers, they have secured numerous negatives of the ruins, embracing many detailed portions. They have also obtained, by means of a plastic material similar to what is used in French stereotyping, upward of two hundred casts from the more important sculptures and mural decorations, several of which are being reproduced in plaster, thus showing the work in facsimile.

Attention was concentrated upon the cities of Uxmal, Chichenitza, Ake, and Mayapan. There are other cities as large as these, but they are in the possession of the hostile Indians. Still other cities exist which are fraught with interest in an exceptional degree, for they have been inhabited by a race of dwarfs, compared with whom the dwarfs of popular exhibitions are almost giants. The diminutive stature of the inhabitants is shown by the buildings, the doorways of which, Dr. and Mrs. Le Plongeon assured us, are thirty-six inches high by eighteen inches in width. One of the largest temples in these dwarf cities is twelve feet long by nine feet wide, everything else about them being in the same ratio of dimensions. The names of some of these cities are Meka, Nicté, and Cankun. These are situated on the east coast of Yucatan, opposite the islands of Mugerés and Cozumel. They are at present very difficult of exploration owing to the frequent visits made by parties of hostile Indians, who are well armed, and in skirmishes with whom no quarter is either expected or given.

In Uxmal there are several ruins in a state of excellent preservation. These prove in an incontestable manner that in early ages a high degree of civilization existed. The date of the erection of several of these edifices is believed to be not less than six thousand years ago, although Dr. Le Plongeon is of opinion that there is much that points to an antiquity of ten thousand years. It being of the greatest importance that the antiquity of these remains of a former civilization should be determined, we here present a few of the reasons given by which this is sought to be established.

In one temple, which is richly decorated both with marble and other stone, portions are profusely covered over with inscriptions and writings in the Maya language, in writing of an ancient nature hitherto unknown, but the key to which has been discovered by Dr. and Mrs. Le Plongeon, by dint of much perseverance. With this new alphabet they have been enabled to decipher many of these records of ages of the long ago. The age of these erections is discoverable, first from the Katuns found in the city of Ake, mentioned by the chroniclers, who tell us that at the time of the Spanish Conquest such Katuns were still being used. These consist of columns of stone, eight in a column. One is placed every twenty years. On the top of the seventh, and at each corner, is placed another stone, these corner stones being laid at intervals of four years, and on the completion of the twenty years represented by them a large stone is placed over all, thus completing the column, or Ahau-Katun, which thus marks a period of one hundred and sixty years. Now, in one building were found thirty-six of these columns, which represents at least six thousand years as the time that had elapsed from the erection of that temple to that at which the last stone was laid on these time columns; and the time that intervened between the completing of these records by the placing of this last stone and the Conquest is not known in this case.

Another guide to the discovery of the antiquity of these erections is the worship of Deity in the form of the mastodon's head. Now, as this animal has been extinct for ten thousand years, it follows that either the builders of these temples or their fathers were familiar with it, for had they not known the mastodon they could not have made an image or a picture of it, and all of the buildings throughout the peninsula are ornamented with the mastodon's head, and some of the sculptures represent human figures in the act of worshipping it.

The buildings in most cases are formed of a white limestone, the stones being all cut nearly to one size and very closely fitted together. The outsides are square, but they are cut in a pyramidal form. The ceiling of the buildings

form a triangular arch; the rooms are generally long and narrow, but very lofty, the walls and floors being cemented with concrete. At Uxmal is a building called Monjas, which consists of a hundred and twenty rooms, all arranged in pairs, each pair communicating with one another by a doorway, but with none of the others, except through the courtyard. There are no interior sculptures, all being on the outside, and in these a certain local style or order has been observed, for while at Uxmal the ornaments are all found above the doorways and facades, at Chichenitza they reach down to the ground. One edifice, known as the Governor's House, is 293 feet in length. They are mostly erected on artificial terraces composed of stones laid on the top of each other, one of these being similar in style to the "hanging gardens" of Babylon.

The great question of popular interest regarding these archæological remains is, What do they teach us? Apart from the history of the family affairs of the contemporary kings, which can now be read with comparative plainness by the explorers, it has been discovered that there is an almost absolute identity between the language, the manners, and customs of these prehistoric Yucatanese and those of Chaldea, Egypt, Hindostan, Persia, Burmah, and Siam, and that an early and cultivated civilization, imagined to be of a higher type than any other, existed in Yucatan. It has also been discovered and established beyond cavil that Freemasonry existed in these prehistoric times with the same Masonic symbols as are now in use, proofs of this being found in the photographs and casts; and that what is now known as mesmerism existed six thousand years ago in very much the same form as it does at present, as shown by the decorations on the frescoed walls. Among the customs common to the Yucatanese, are to be found some also common to the inhabitants of Hindostan, such as the manner of carrying children astride on the hip. The making of an impression of the hand in red pigment on the walls of certain sacred edifices was common in former times both to Yucatan, to Elephanta and other places in India, and even in caves in Australia and others of the South Sea Islands. There is scarcely a monument in Yucatan upon which is not to be found the impression of a red hand, this being the record of a vow made to the Gods. Fire worship, phallic and mastodon worship, together with gods having elephants' heads, flourished in Yucatan in these early periods.

The Maya language, still spoken in Yucatan, was also known in many parts of the East. The last words of Jesus of Nazareth, Eloi, Eloi, lama sabachthani, are said to be pure Maya words, and to mean, "Now, now, I sink; darkness comes over my face." From the narrative, it would seem that none of those standing within hearing understood the language made use of, as they imagined he was calling upon Elias to aid him. Enough has here been said to indicate the great interest that attaches to Yucatan.

THE BURSTING OF ARMATURES.

The bursting of the armature of a dynamo, as recently reported in the daily papers, has caused much comment as to the possible danger arising from accidents of this kind, and, as usual, conclusions have been arrived at without any inquiry being made as to the facts of the case. Knowing that there is danger from flying fragments when a rapidly revolving mass is disrupted, and recalling the damage done by flywheels and grindstones, the writers guess that the effects produced by armatures acting similarly would be equally disastrous.

In some classes of dynamos the armature consists of a shaft upon which are placed many hundreds of disks of iron separated by paper, and around which coils of copper wire are wound longitudinally. Upon revolving this, the centrifugal force tends to throw the copper wire off, but to hold it in place strands of spring brass wire or piano wire are bound at intervals about it. These confining bands have to resist the weight of copper only, the tensile strength of the disks being ample so far as they are concerned. Taking the diameter of the armature as twelve inches, and the speed as one thousand revolutions per minute, each pound on the circumference would exert a force of about one hundred and sixty-nine pounds. The aggregate number of pounds of copper on the surface would cause a strain to be resisted by the combined strength of the copper wire itself and the confining bands. The difference is sufficient for a large margin of safety.

When the armature is made of cast iron, the tensile strength of the iron will resist the centrifugal force if the casting be without flaw, and the high degree of perfection to which casting is brought at the present time makes this aspect of the question hardly worth considering.

The armature first considered is so incased by massive field magnets, and the fragments would be so light in comparison, that but little danger would menace either life or property in case of rupture.

It is not much use asserting, says the Lancet, that assemblies of sane persons ought not to become victims of panic; but, in truth, unless the nervous system of man could be reconstructed on a new principle, which would necessarily deprive it of some of its most excellent qualities, it is impossible that there will not always be a tendency to impart and receive this impression, which so powerfully affects the body and mind that judgment is for the time suspended, and the limbs either refuse to act impulsively or under the control of the emotional part of the being. Discipline is the only remedy for a tendency to panic.

**THE CLOCK OF STRASSBURG.**

The late transit of Venus curiously proved the accurate calculations of the ancient makers of that famous horological curiosity, the Strassburg clock. A few days before the transit, the *American Register* tells us, visitors to the cathedral, inspecting in the planetarium attached to the clock, noticed that one of the small gilt balls representing Venus was gradually moving toward a point between the sun and the earth, and on the day of the passage the ball stood exactly between them. Old Conrad Dasypodius, the Strassburg mathematician, superintended the manufacture of the clock and its accompanying planetarium some time between 1571-74, the dates differing according to various authorities; and it is interesting to note that, after three hundred years of existence, the clock faithfully fulfills the calculations of its dead inventor.

A correspondent sends the foregoing, which is quoted from the *London Graphic*, expresses doubts of its correctness, and asks for information. One of our astronomical correspondents sends us the following notes:

The construction of a machine which would exhibit accurately the motions, distances, and magnitudes of the planets, and could be kept in running order for three hundred years, is an impossibility. Such a piece of machinery would require the skill of the Great Architect of worlds.

The history of the Strassburg clock and the planetarium connected with it bears witness, like everything else, to the imperfection of workmanship, and the frequent necessity of changes and repairs.

The clock stands in the cathedral, and dates back to 1352, when it was put up under the patronage of Berthold de Buchek, at that time Bishop of Strassburg. As time passed on, the clock got out of order, and in 1547 three distinguished mathematicians were commissioned to put it in repair. They all died before the work was finished, and Conrad Dasypodius undertook the responsible task, which he completed in four years. The clock worked well until 1783, the year of the Great Revolution, when it struck for the last time.

It was left undisturbed for nearly fifty years, and fell into a dilapidated condition, mournful to behold. An effort was then made for its restoration. This was found to be impossible, for the works were rendered almost useless by rust and verdigris. Finally, Schwilgue, an artist and mathematician of Strassburg, undertook to repair, modify, and re-instate the clock. He commenced the task in 1836, and, after working four years, completed it in 1840.

A mythical story is told of him, which does not redound to the honor of his fellow citizens. It is said that he had engaged to construct a similar clock for the capital of one of the Swiss cantons, and that his ingrateful townsmen put out his eyes to prevent his fulfillment of the contract.

Schwilgue placed the mechanism of the old clock in the old casing, after skillful improvements and alterations, where it continues to be a source of proud satisfaction to the inhabitants of Strassburg, and an unerring object of attraction to travelers from all quarters of the globe. Besides the remarkable performances connected with the regular clockwork, it shows the sidereal time, the movements of the planetary system, and the precession of the equinoxes. It is claimed that the mechanism is so perfectly elaborated that it marks the 29th of February in every leap year.

It is not impossible that the planetarium may have marked the transit of Venus on the 6th of December last, for if the inclination of the orbits of Venus and the earth to the ecliptic is accurately represented, Venus must sometimes be at a point directly between the earth and the sun, and consequently make a transit over his disk. The possibility of such an occurrence probably never entered the mind of the ancient Conrad Dasypodius; much less had he power to make the accurate planetary arrangements to bring about a result, after a lapse of three hundred years, depending on contingencies then unknown. It was not until the seventeenth century that Kepler so far improved the planetary tables as to predict that a transit of Venus would occur on the 6th of December, 1631.

We have no means of knowing what improvements Schwilgue made in the ancient piece of mechanism, but it is safe to say that absolute perfection was not attained. If Venus did actually wheel into line between the earth and sun on the 6th of last December, we are inclined to think it must have been a simple coincidence rather than a result of profound mathematical calculation. If such were not the case, why did we hear nothing of the transit of Venus in 1874, nor of the six transits of Mercury that have taken place since the planetarium was put in order in 1840?

**INSECTS AND PLANTS.**

The tenth of the course of the Saturday lectures under the auspices of the Biological and Anthropological Societies of Washington was delivered by Professor C. V. Riley, his subject being "Adaptation and Interdependence between Plants and Insects."

The first part of the lecture consisted in a popular exposition of the more curious and striking facts that have of late years been ascertained in reference to the mutual adaptation between flowers and insects, and particularly to the movements, structure, digestive powers, and other peculiarities of insectivorous plants. This part of the lecture was illustrated by colored diagrams, and included some of the lecturer's own observations.

The second part of the lecture was devoted to some general conclusions which the facts naturally led to. Here

the chief aim seemed to be to emphasize the principles of evolution as applicable to the development of special or peculiar structures. The attention and approval manifested by the audience were noteworthy as indicating the increasing acceptance by the intelligent masses of the more modern biological ideas.

We give some of the closing words of the lecturer, who described many of the actions of insects as rational and the movements of plants as voluntary: "It may be that plants can appreciate neither pleasure nor pain, and that all their actions are reflex and automatic, but, if so, then so are the majority of the movements, not only of the lower, but likewise of the higher animals. It may be that all the actions of insects and the lower animals are instinctive; but I prefer to believe, and feel convinced, that many of them are rational.

"Allowing all the power they deserve to radiation, light, heat, electricity, etc., and they yet fail to explain these plant motions which I have called voluntary, and which are performed independently of those influences. Darwin, in the last published work of his life, felt obliged to use the word *perceive* in reference to many of these movements, and it is difficult to conceive of irritation without sensation.

"Protoplasm is, so far as we know, the basis of both vital and psychic phenomena, and the manifestations of sensation and consciousness are of the same nature throughout the organic world. They differ only in degree, and it will ever remain, perhaps, a matter of opinion and faith as to just where volition and consciousness begin, or, to use another figure, just how much concentration or massing of the protoplasm or how much organization of structure is necessary to intensify those phenomena into consciousness. One thing is certain and profoundly significant, viz., that the lowest organism and the first existent on our planet possessed at some stage of development—whether in the embryonic, larval, or the sexual state—the power of independent motion—activity. It matters little whether we call them animals or plants; they were, and their present representatives yet are, perhaps, combinations of both. They represented the potentiality which has developed on the one side the most complex animal intelligence, and on the other the highest vegetative organization.

"One thing at least I hope I have demonstrated, viz., that the study of nature loses nothing of interest by the developmental principle that her manifestations are due to secondary laws; that in tracing the origin of things, as they now exist, from pre-existing things the mind is but grasping at the method by which the Creator works. There must ever remain to the philosophic student of life upon our planet a sense of his nescience of the ultimate first cause—the Infinite; and the highest induction as to this infinity is perfectly consistent with the theory of evolution so irresistibly impressed upon those who study aright the great book of Nature!"

**Incidents in a Philosopher's Boyhood.**

Prof. Joseph Henry, one of the most eminent of American scientists, died May 13, 1878. On Thursday, the 19th day of the present month, his memory is to be honored by the unveiling at Washington of a magnificent bronze statue, made by W. M. Story, and costing \$15,000.

Among the interesting reminiscences of his boyhood is the story of his first pair of boots—a true story, often told by himself in later years.

When he was a boy, it was the universal custom to have boots made to order, and his grandmother, with whom he was living, indulgently allowed him to choose the style for himself. There was no great variety of styles. Indeed, the choice was limited to the question of round toes or square toes. Day after day Joseph went to the cobbler's and talked over the matter without coming to a decision, and this even after their manufacture was begun, until at last the shoemaker, fairly out of patience, took the decision into his own hands and made a most remarkable pair of boots—one boot round toed, the other square toed.

Later in life Prof. Henry often came deliberately to his decisions, with the advantage that he seldom if ever had occasion to abandon them.

While Joseph was a schoolboy he acquired a taste for reading in this peculiar way: One day he chased a pet rabbit through an opening in the foundation wall of the village meeting-house. While crawling about among dirt and rubbish a gleam of light enticed him through the broken floor, and he found himself in a room containing the open bookcase of the town library. The title of one of the books struck his fancy and he took it down. It was Brooks' "Fool of Quality," and he read, coming again and again through the hole in the floor, until access by the door was finally granted him. From this first book that he ever read with relish, he passed on eagerly to other works of fiction in that library.

A few years later, in a way almost equally accidental, his mind was turned to an entirely different class of reading.

Confined at home by a temporary illness, he took up a book casually left on the table by a boarder, and entitled "Lectures on Experimental Philosophy, Astronomy, and Chemistry, intended chiefly for the Use of Young Persons. By G. Gregory." It began with a few questions: "You throw a stone, or shoot an arrow into the air; why does it not go forward in the line or direction that you give it? . . . Why does flame or smoke always mount upward, though no force is used to send them in that direction? And why should not the flame of a candle drop toward the floor,

when you reverse it or hold it downward?"

Again, you look into a clear well of water and see your own face and figure, as if painted there. Why is this? You are told it is done by the reflection of light. But what is the reflection of light?"

The trifling incident of taking up this book may be said to have turned the whole course of this lad's life.

After his death this book was found in Professor Henry's library with the following entry upon the fly-leaf, written in his own hand:

"This book, although by no means a profound work, has, under Providence, exerted a remarkable influence upon my life. It accidentally fell into my hands when I was about sixteen years old, and was the first work I ever read with attention. It opened to me a new world of thought and enjoyment; invested things before almost unnoticed with the highest interest; fixed my mind on the study of nature, and caused me to resolve at the time of reading it that I would immediately commence to devote my life to the acquisition of knowledge."

Many young men quit school at sixteen years of age. They should take a lesson from Joseph Henry, and regard education as not completed, but just begun.

C. P. OSBORNE.

**Fishing by Electricity.**

According to a correspondent of the *Philadelphia Press*, the electrical apparatus of Professor Baird's expedition is very complete. The search light is one of the most novel of the wonderful inventions of the nineteenth century. It consists of three Edison electric lights of 16 candle power each, inclosed in a hermetically sealed glass case, which is surrounded by a glass globe, and capable of resisting the pressure of the water at a great depth. It is proposed to sink the lamp and illuminate the sea by turning on the light. This, it is expected, will attract the fish, and a net ten feet in diameter at its mouth placed below the light will be drawn at the proper time, and the unknown fish of the lower waters will be caught. "It is an improvement," said one of the officers of the ship, "on the method of the Indian who searched the rivers at night time with a burning pine knot in the bow of his canoe and a spear in his hand, but the idea is really stolen from him."

Paymaster Read has the most perfect arrangements for his work. He will be able to photograph fish and shells, as soon as they are taken out of the water, by a vertical camera. This is necessary, as in some cases the air changes the form of some of the curiosities of the sea. The sea water will also be brought to the surface from any depth desired for analysis. During the trip of the *Albatross* from Wilmington an arc light has been first successfully operated on an Edison circuit, and an invention has been completed for lighting the surface of the sea, which will be useful for signaling and for the prosecution of all kinds of work at night.

**An Internal Mite in Fowls.**

Professor Thomas Taylor, microscopist of the Department of Agriculture, had occasion recently to dissect a sick chicken, and he found that all parts of the lungs, the bronchiæ, and the linings of the thorax and abdominal cavities were covered more or less thickly with a mite. An examination we were requested to make showed it to be in all respects identical with *Cytolæchus sarcoptoides*, Mègnin. This parasite is known in Europe to inhabit the air passages of gallinaceous birds, giving the transparent and membranous linings of these passages the appearance of gold beater's skin speckled with flour. It is likewise found in the bronchial tubes and their divisions, and even in the bones with which the air sacs communicate. Mègnin believes that while the mite may be extremely numerous, so as to cause mucous irritation and induce asphyxia and congestion by obstruction of the bronchiæ, and that birds may thus die, yet it is incapable of causing, as Gerlach and Zundel believe, enteritis or inflammation of the peritoneum.

**Talking One Thousand Miles.**

We recently described some extraordinary telephone experiments on the Postal Telegraph Company's line between this city and Cleveland, O., a distance of six hundred and fifty miles. This experiment was so successful that it was expected the distance could be greatly extended. The Postal Telegraph Company's wire now reaches Chicago, which is distant one thousand miles, and we are informed that telephonic communication has been carried on for some days between this city and Chicago; the transaction of business over the line by this means being an every day occurrence. The instrument used in this experiment is the Hopkins telephone, described in our former article.

MOUNT ÆTNA is in eruption, pouring out from the central crater a stream of lava. Vesuvius is in its usual passive state, although there is always a subterranean stream of lava flowing. Visitors are conducted by guides to the spot where the liquid fire may be seen through an aperture in the solid crust of lava. The column of smoke constantly ascends, and at intervals at night there is a brilliant light.

NEW subscribers to the SCIENTIFIC AMERICAN and SCIENTIFIC AMERICAN SUPPLEMENT, who may desire to have complete volumes, can have the back numbers of either paper sent to them to the commencement of the year. Bound volumes of the SCIENTIFIC AMERICAN and SCIENTIFIC AMERICAN SUPPLEMENT for 1882, may be had at this office, or obtained through news agents.

**The Steam Engine.**

The *Commercial Bulletin* justly concludes that it seems like a reproach upon the mechanical skill and ingenuity of the nineteenth century that nine-tenths of the caloric force applied to even the most economical steam engine is wasted. That is to say, every ton of coal is one-third wasted in the process of generating steam, and when the steam is once formed, only one-seventh of it is actually converted into work by the engine. The remaining six-sevenths is lost either in the exhaust or through radiation from the cylinders or in similar ways; so that only one-seventh of two-thirds, or about one-tenth of the whole heating power of the fuel, becomes actually embodied in the working power of the engine.

An actual test made with the pumping engine of the Lynn (Mass.) water works showed that of 4,264,125 units of heat generated by the furnace, only 2,793,660 (or 66 per cent) were converted into steam, and only 430,625 (or a trifle less than 10 per cent) contributed to the working force of the engine. A unit of heat is the amount required to raise the temperature of a pound of water one degree, and is one forty-second part of a horse power. It follows, therefore, from the above figures that of 100,000 horse power generated in the furnace of the Lynn pumping engine, 35,000 were wasted between the furnace and the boiler and 55,000 in the engine.

But even those results were only obtained on one of the most economical of engines. A common high pressure engine of the best type usually utilizes but 6 per cent of the energy generated by the fuel. In locomotive engines only 2½ per cent of the caloric power is used.

Invention is said to be the result of two things: first of the sagacity which has discerned a want; and secondly of a resolute effort to supply that want. The first of these requisites is evidently at hand in the case of the steam engine, and if "necessity is the mother of invention," the second ought not to be wanting in this age of marvelous mechanical and scientific achievements.

**Economy in Hops.**

The extraordinary prices which hops have fetched this season must have set many brewers thinking as to how some economy might be effected. Any process, says the *Brewers' Guardian*, by which three pounds of hops can be made to go as far as four pounds would be of enormous value. Many suggestions have been made, but we hear of none of them being practically applied. There seems to be two ways in which some economy in hops might be effected: one is to grind or tear the hops before maceration, so that their essence may be more easily and completely extracted; the other is to prevent the loss of the essential oil by extracting the hops in closed vessels. Long boiling undoubtedly dissipates much of the fragrant aroma of the hop, as the neighborhood of any brewery so frequently testifies. If the hops were submitted, prior to boiling, to a current of steam at high pressure, a large percentage of the volatile oil might be condensed and collected; this oil could be added to the wort at the termination of the boiling, and the steamed hops could be boiled with the wort as usual; our brewery engineers ought to have no difficulty in devising and constructing the necessary plant for this operation, and its cost would soon be saved in a season like the present.

**IMPROVED SAWING MACHINE.**

Our engraving represents an improved sawing machine recently patented by Mr. H. K. Olson, of Coalville, Utah Ter., and designed for felling trees and sawing logs into lengths. The machine can be driven by hand or power, and is capable of working either horizontally or vertically. It has an automatic screw feed for moving the saw forward when making a horizontal cut, and this feed is readily detached when it is desired to saw vertically, so as to allow the saw to feed by its own gravity. The entire apparatus is mounted on a light portable frame, so that it may be easily transported from tree to tree or log to log, as occasion may require. The crank shaft and the driving shaft are mounted in sliding boxes, movable up and down by the windlass at the top of the inclined posts. The crank is wide to admit of the lateral movement of the connecting rod, and it is adjustable as to the length of its stroke; the design of this arrangement being to adapt the machine to different kinds of work. The saw guide moves through a sleeve that is adjustable along the slotted bar by means of the screw in the slot of the bar. The screw receives its motion from the driving shaft of the machine by a belt. As the crank of the drive wheel is turned the saw is reciprocated, and at the same time moved forward to its work. When it is desired to saw vertically, the feeding screw is disconnected from the saw guide, and the slotted bar is placed in a vertical position, as shown in dotted lines in the engraving. The joint between the saw guide and the connecting rod is swiveled to admit of turning the saw at any desired angle. This machine works rapidly and easily, and may be operated by one or more men, or by horse or steam power.

The ordinary speed to run a pump is one hundred feet of piston per minute.

**NEW LAMP EXTINGUISHER.**

The extinguisher shown in our engraving is applicable to all forms of lamps, and is capable of putting out the flame instantly, without the slightest danger of exploding the lamp. It is well known that to extinguish a lamp by blowing down the chimney is a dangerous operation, especially where the lighter grades of oil are used. It is troublesome to remove the chimney whenever it is desired to put out the lamp, and blowing from beneath does not usually accomplish the object.

The ingenious invention shown in the engraving obviates all these difficulties, and adds but a mere trifle to the cost of the lamp. Two extinguishing plates, hinged under the cap

**GREENHALGH'S LAMP EXTINGUISHER.**

and near the wick tube, are provided with arms, which project outward and through oblique slots in a plate connected with a wire that extends downward along the side of the lamp and its standard, and is provided with a knob or handle, by which it may be readily pulled down, so as to effect the closing of the extinguishers over the end of the wick tube. A spring surrounding the wire returns the parts to their normal condition.

This useful invention has been patented by Mr. John B. Greenhalgh, of Blackstone, Mass.

**The London Fish Exhibition.**

The largest and most complete fish show ever held will be opened by Queen Victoria at the South Kensington Gardens, London, during May, which in importance and extent, it is expected, will eclipse the great German Exhibition of 1879. All branches connected with fish or fishing in their practical, commercial, scientific, and historic ways will be represented. One class of exhibits will include sea fishing gear

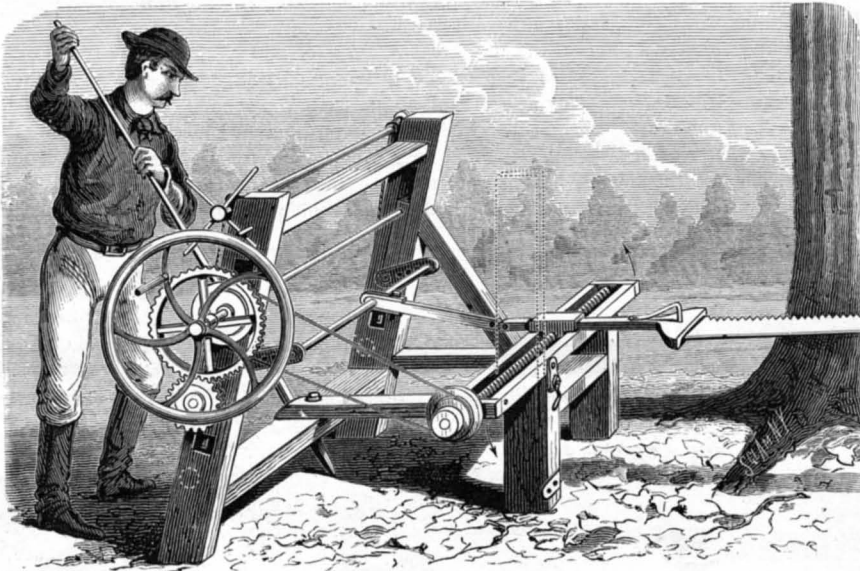
**OLSON'S SAWING MACHINE.**

of all kinds. Fresh water fishing will be represented by rods, reels, artificial flies, etc. Another class will show all kinds of articles used and worn by fishermen, even to the clothing. Fish in all forms, canned and uncanned, as prepared for commerce will occupy a large space, and will constitute one of the most important features of the show.

From former shows of this kind held in Europe great benefit has been reaped by this country. Above all, a vast increase of export trade for American fish products has sprung up from these exhibitions. To Australia alone are now sent ten times as many of these products as in 1870—last year's shipments amounting to two million dollars.

The fishing interests of the United States greatly exceed

those of any other country, and it is expected that the exhibits shown by us will surpass all others in the completeness and variety of articles shown. For the collective exhibit at Berlin the United States obtained the first prize and the greatest fame; and the collection made up for London is more perfect, especially in angler's material, than the one sent to Berlin.

Prof. Baird has loaned and sent over from the Smithsonian Institution a very large and important collection of fresh, stuffed, and preserved fish, and many plaster casts of odd and curious occupants of the sea. The spacious structure in which the exhibition is to be held is located in the beautiful gardens of South Kensington.

A visitor, in passing through the main entrance, will find himself opposite a spacious lobby, the walls of which are marked at the sides "Great Britain," and so apprising him that the space is to be devoted to articles connected with the British fisheries. To the left, just immediately on entering, are spacious dining rooms with large kitchens in the rear, while to the right and left, running from the central walk which goes due north, stretch east and west on each side respectively, the halls for life boats, of which there will be a grand display, a prize of \$3,000 being offered for the best and safest; and the machinery in motion, such as for fish curing and tackle making. Beyond these ranges, and immediately on entering upon the foreign and colonial branches, a site is being prepared for the Prince of Wales' pavilion.

Passing the royal pavilion, will be found arranged, running east and west, exhibits from Newfoundland and the Netherlands, the former, no doubt, being mostly representative of cod fishing on the world-famed banks. The sections for America, Canada, Newfoundland, Norway, Sweden, the Netherlands, and Belgium apply for an average of 10,000 square feet each; China, Japan, India, and New South Wales requiring together about 30,000 square feet.

The United States exhibit will be found to the left, alongside of that for Canada, while running north and south, parallel and alongside, will be the collections of Sweden and Norway; Spain and New South Wales occupy, together with China, corridors in the right wing; the Chinese exhibits will be arranged in the form of a pagoda. Great Britain, again, runs right round the outside of the exhibition, through the conservatory on the north down to where the aquarium will be situated. Close to the aquarium will be found the exhibits of Belgium and Russia, which will also be well represented. A fish market at the right entrance will be an interesting feature, and the fish dinners in the dining rooms will, no doubt, be indulged in by many; simply with a view to learn how many different ways a fish may be cooked after it has been hooked.

The Berlin exhibition was visited by 483,000 people, while this one in London, a city of 5,000,000 inhabitants, will unquestionably be visited by several millions.

The American commission who go out in charge of the United States exhibit are Prof. G. Brown Goode, Deputy U. S. Fish Commissioner; Mr. R. E. Earl, in charge of fish culture; Capt. J. W. Collins, in charge of nets, boats, and marine fisheries; Mr. Joseph Palmer, taxidermist; Mr. Reuben Wood, in care of the angling exhibit; a secretary, and perhaps others.

**The Cost of Stopping a Train.**

This is a problem which may possibly be cleared up one of these days, but just now the outlook in that direction is not promising. The best plan would seem to be, to get a large number of experienced railroad men to guess at it and then average the guesses. This would be an approximation near enough, perhaps, for all practical purposes.

Any one who will figure the cost of stopping a passenger train down to the fraction of a cent, and then prove his figuring to be correct, will beat the weather prophets all to pieces. A very little reflection, however, ought to satisfy any rational mind that it is quite impossible to disentangle and separate all the elements of cost, that enter into the stopping of any particular train from the various elements of cost involved in the general operations of a road.

There is manifestly no dividing line by means of which the former can be eliminated with any degree of precision. The basis upon which to work in order to arrive at an approximate result is more unreliable than that upon which the mileage cost of transporting freight is estimated, and apparently of much less importance. It is a problem, as it seems to us, that is more speculative than practical.

The making of stops by railroad trains is a necessity, no matter what the cost may be. The cost of the regular stops of passenger trains is probably about as little as it can be with due regard for the interests of the traffic, and if such cost could be ascertained with absolute certainty for each and every train, it would amount to little more than a curious piece of information.—*National Car Builder.*

Messrs. Emerson, Smith & Co., Beaver Falls, Pa., have received notice that, with a 68-inch No. 7 gauge circular saw purchased from them, Messrs. Terry & Casey, of New Orleans, lately sawed 600 feet of 6 x 8, 8 feet long, 200 feet 1½ x 14 inches, and 260 feet of inch boards, all yellow pine, in three minutes, making 1,060 feet in all.

**TORPEDO BOATS IN COLLISION.**

Last year the Italian Government made some very exhaustive experiments at Spezia with the numerous torpedo boats they then had. Some of these were supplied by Messrs. Yarrow & Co., of Poplar, and the annexed engravings represents one of them, named the Falco, which, during some maneuvers round one of the large Italian ironclads, was run into by a similar torpedo boat built by the same firm. The *Engineer* says, at the time of the collision, which took place inside the breakwater in the Gulf of Spezia, the two boats were running at a speed of nearly fourteen knots, which speed was perhaps reduced to ten knots at the actual instant of the collision. The Falco was saved from sinking partly by the water-tight bulkhead, which happened to be close to where she was struck and partly by her pumping machinery. An idea of the extent of the damage sustained is very clearly given by the sketches. The fore end of the ram of the other boat not only penetrated the starboard side, but went right through and out beyond the port side of the Falco. However, both the boats could steam on, and reached the dockyard at Spezia in safety. It was satisfactory to find that the engines and all the accessories on board the Falco sustained no damage whatever by the shock, which was entirely confined to the head of the boat. It is the opinion of the Italian authorities that, had the boats been less strongly and substantially built, one at least must have gone to the bottom. These first-class torpedo boats, which are 100 feet in length by 12 feet 6 inches beam, one of which, it will be remembered, attained the remarkable speed of 23.4 knots when tried in London, have been in commission the greater part of last year, making numerous cruises from Spezia along the coast, and constantly at exercise. One important feature in these boats is an arrangement introduced by Messrs. Yarrow & Co., by which means, if the stoke-hole becomes flooded with water through the boat's side being penetrated or otherwise, the fire would not be extinguished, which, on account of the low position of the fire grate in boats of this class, would otherwise almost immediately result from only a very small quantity of water finding its way into the stoke hole. The value of this arrangement is clearly evident from such an accident as we now illustrate.

SIR WILLIAM THOMSON follows Dr. Thomas Reid in ascribing to man six senses instead of five, namely, the sense of force, of heat, of sound, of light, of taste, and of smell.

**Perpetual Motion Clocks.**

There is an automatic clock at the Stock Exchange, London, which has now performed very well for six months, invented by a M. Dardeme. The winding apparatus consists of a small windmill, fixed in a chimney, or any other place where a tolerably constant current of air can be relied upon. By means of a reversed train of multiplying wheels this windmill is continually driving a Hughs' endless chain remontoire, a device well known to clock makers. A pawl acting on a wheel prevents the motor from turning the wrong way, and, by a simple arrangement, whenever the weight is wound up right to the top, the motion is checked by a friction brake automatically applied to the anemometer by the raised weight lifting a lever. When the weight is thus raised to the top, the clock has a sufficient store of energy to go for eight days or more, so that it will be seen that it is by no means dependent on a regular current of air.

horizontally and terminates in the tool, X, is placed upon a platform, A, which is provided underneath with two grooves, a, by means of which it rests upon the rails, B. It is upon these latter that the entire machine moves according to the advance made by the tool. This motion of the machine on the rails is effected by means of a mechanism whose principal parts are contained in the frame, C, which is affixed to the bottom of the quarry.

The platform, A, is, in fact, attached to the extremities of two chains, D, which at one end run over the indented pulleys, E (Figs. 7 and 8), then pass through the interior of the rails, and afterward run over two like pulleys whose axles are united, through sleeves, F, with a transverse shaft, G. This latter carries in the interior of the frame, C, a wheel, H, with helicoidal teeth, which engage with an endless screw, H', forged with the vertical shaft, I. The upper extremity of this latter carries a bevel wheel, J, which is driven by the similar wheel, J', mounted on the shaft, J'', to which are attached the maneuvering winches.

It will be seen that through this easily movable arrangement of the wheels and shaft, G, the frame or rails may be moved, the driving gear be arranged at one or the other extremity of the latter, or the position of the two rails be reversed, since the four pulleys, E, are exactly alike.

The motor used to drive the apparatus is a Gramme dynamo electric machine, which is itself set in motion by a like machine that may be placed outside of the mine

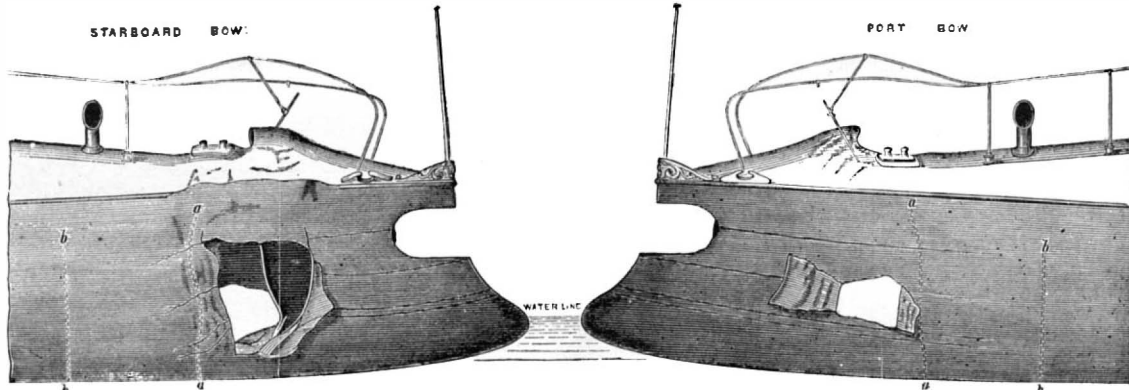

**A TORPEDO BOAT COLLISION.**

The Belgian Government has for the past two years adopted this system of clocks on the State railways, and we are informed that they are now being tested by certain English railway companies with a view to their adoption.

**CHENOT'S ATMOSPHERIC ROCK DRILL.**

The accompanying plate, reproduced from the *Publication Industrielle*, shows the details of a very effective rock-cutting machine devised by Mr. Chenot for forming horizontal grooves in mines or quarries, in order that the rock may be taken out in blocks.

Fig. 1 represents the machine in longitudinal section through the axis of the tool carrier. Fig. 2 is a horizontal projection of it, the frame containing the driving gear for moving the machine on its rails being shown in section. Fig. 3 is an end view of the tool carrier driving gear, but partially in section on the line 5-6. Fig. 4 shows a transverse section of the frame just mentioned.

The machinery of this hammer, which is here arranged

or quarry, and at a considerable distance away from it. This electric machine, K, is fixed upon the same platform as the hammer, and the axle, K', of the induced ring is provided at each of its extremities with a friction wheel, L, designed for actuating two large disks, L', that are affixed to the transverse axle, M, which carries two pulleys, M'. These latter are put in connection, through the belts, b, with two pulleys, M'', on the cranked shaft, N, to which is attached the connecting rod, N', that sets the tool carrier in motion. This part of the mechanism may be seen not only in Fig. 1, but also in Fig. 5, which is a transverse view of the machine on the line 1-2, and in Fig. 6, which is a corresponding side view of the same mechanism.

The shaft, M, is not absolutely fixed, but is carried, on the contrary, on two vertical rocking levers, O, which are affixed to a horizontal axle revolving in a bush, c. These two levers, which are connected at their upper part by a crosspiece, d, are coupled with two rods, P, which are pivoted upon pins belonging to an axle, P', but which are made

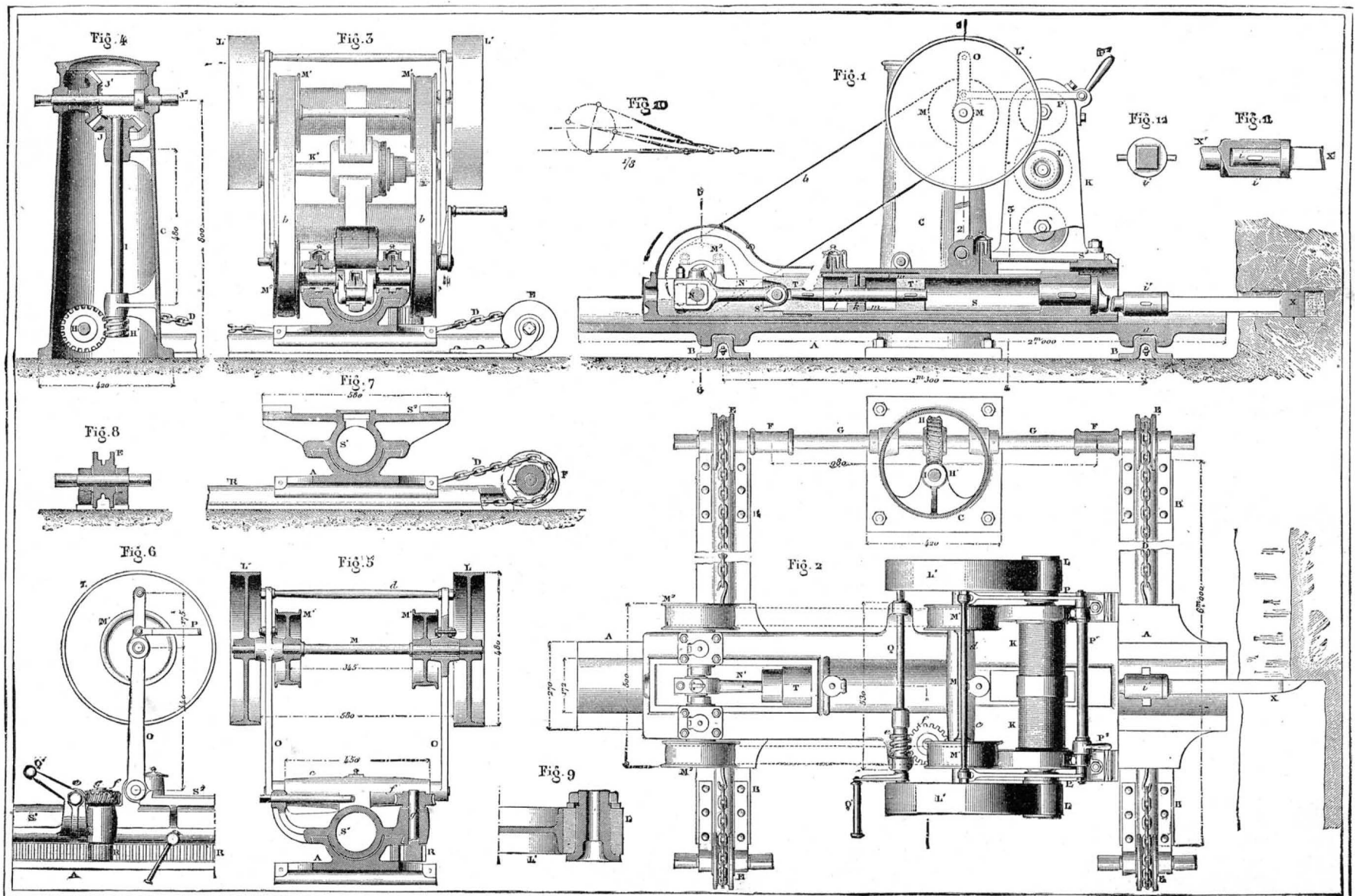

**IMPROVED PNEUMATIC ROCK DRILL.**

slightly eccentric in order that they may operate as cranks of short radius. The axle, P, is provided with a lever handle, P<sup>2</sup>, for causing it to oscillate and to thus bring about an oscillation, in one direction or the other, of the frame that carries the axle of the disks, L—that is to say, these latter are put in contact, at will, with the friction wheels, L, or isolated therefrom, according as it is desired to set the hammer in operation or stop it.

By modifying the pressure between the parts, L and L', the speed of the hammer may be either checked or carried to its maximum. It should be stated that this system of frictional driving gear has been found to work just as well when applied to the electric machine as to all those high-speed apparatus in which it is not prudent to attempt a sudden change from a state of rest to a maximum of velocity, and *vice versa*.

It results, also, from the arrangement that we have just pointed out, that it is by bringing the parts, L and L', in contact that the belt acquires sufficient tension to carry along the pulleys, M<sup>2</sup>, while it slackens naturally when the mechanism is thrown out of gear.

The maneuver by which the entire machine is moved along the platform, A, to regulate the distance of the tool from the surface to be operated upon, and also to change its position in measure as the cutting deepens, is likewise performed by hand. The mechanism by means of which this operation is effected may be seen in Figs. 2, 5, and 6. It consists of a horizontal shaft, Q, carrying an endless screw, e, that engages with a wheel, f. This latter is fixed upon a vertical shaft, g, to whose lower part is forged a straight pinion, R, which gears with a rack, R', affixed to the side of the platform. It is by acting upon the winch, Q, then, that the machine is moved so as to bring the tool to its point of attack. Every time the position is changed the machine is fixed firmly in place by means of a binding screw provided with a handle, h (Fig. 6).

#### ARRANGEMENT OF THE TOOL CARRIER AND ITS MOTOR.

The tool carrier, properly so called, consists of a tube, S, sliding by slight friction in a hollow cylinder which is cast in a piece with the plate, S<sup>2</sup>, upon which are fixed all the parts composing the machine. This plate and the cylinder, S<sup>1</sup> (as shown in the transverse section in Fig. 7), are mounted like a carriage upon the platform, A. The tool, X, is a steel bar having a cylindrical base, i, by means of which it is keyed to the socket, i' (Figs. 11 and 12). This latter belongs to a piece, X', which is united by a similar keying to the movable tube, S. It is in the interior of this latter that move the two pistons, T and T', that are affixed to the rod, j, to which is attached the rod, N', of the driving gear. These two pistons, which have an ordinary backward and forward motion, operate on each side of a fixed cut-off, k.

There result from this arrangement two chambers, l and m, in whose interior the air is alternately compressed and expanded between the fixed partition and the surfaces of the pistons. So, then, when by virtue of the motion communicated by the connecting rod, the two pistons move from left to right, the air, through the inertia of the tube and its equipments, becomes compressed in the chamber, l, until such compression is sufficient to overcome the said inertia and to give an outward thrust to the tool. In the contrary motion it is evident that compression will occur in the chamber, m, and bring about a return of the tool.

Seeing that it would be impossible to keep these air chambers absolutely closed, and consequently at the same degree of mean tension, they are arranged so as to be in constant communication with the external air through two apertures, l' and m', which are sufficiently large to allow a re-entrance of the air during the period of expansion, and which do not interfere with compression, since they are closed by the corresponding piston as soon as compression begins.

We show by the aid of a geometrical diagram, in Fig. 10, the relation between the rotary motion of the driving shaft and that of the tool carrier, whose axis is nearly tangential to the circle described by the head of the connecting rod, so that the whole resolution of the motion is carried over to the inactive return period.

It is estimated that the forward thrust of the hammer is effected while the crank is describing only one-twelfth of a revolution. Now, this shaft being very well able to make 240 revolutions per minute, it results that the contact of the tool with the rock cannot last more than one forty-eighth of a second. The striking of the bar is effected, then, with sufficient velocity to permit the machine to be moved at the same time with all the facility desirable.

This utilization of compressed air, which establishes the sole interdependence of the tube and pistons, is also accompanied by an independence between the travel of the tool and that of the hammer which is highly advantageous; for, according as the rock is more or less penetrable, the tool

reaches or does not reach its maximum travel, and it is the air chambers that undergo the sole consequences of it.

In conclusion, we may state that it is possible with this machine to make cuttings as much as two meters in depth in slaty rocks.

#### THE FIRST TELEPHONE, AS DESCRIBED BY THE INVENTOR.

The following is a copy of an autograph description of Reis' telephone, which has been presented to the library of the Society of Telegraph Engineers and Electricians, London, by Mr. William Ladd, member:

[COPY.]

INSTITUT GARNIER,  
FRIEDRICHSDORF.

DEAR SIR: I am very sorry not to have been in Frankfort when you were there at Mr. Albert's, by whom I have been informed that you have purchased one of my newly-invented instruments (telephones), though I will do all in my power to give you the most ample explanations on the subject. I am sure that personal communication would have been preferable, specially as I was told that you will show the apparatus at your next scientific meeting, and thus introduce the apparatus in your country.

Tunes and sounds of any kind are only brought to our conception by the condensations and rarefactions of air or any other medium in which we may find ourselves. By every condensation the tympanum of our ear is pressed inward, by every rarefaction it is pressed outward, and thus the tympanum performs oscillations like a pendulum. The smaller or greater number of the oscillations made in a second gives us, by help of the small bones in our ear and the auditory nerve, the idea of a higher or lower tune.

It was no hard labor, either to imagine that any other membrane beside that of our ear could be brought to make similar oscillations, if spanned in a proper manner and if taken in good proportions, or to make use of these oscillations for the interruption of a galvanic current. However,

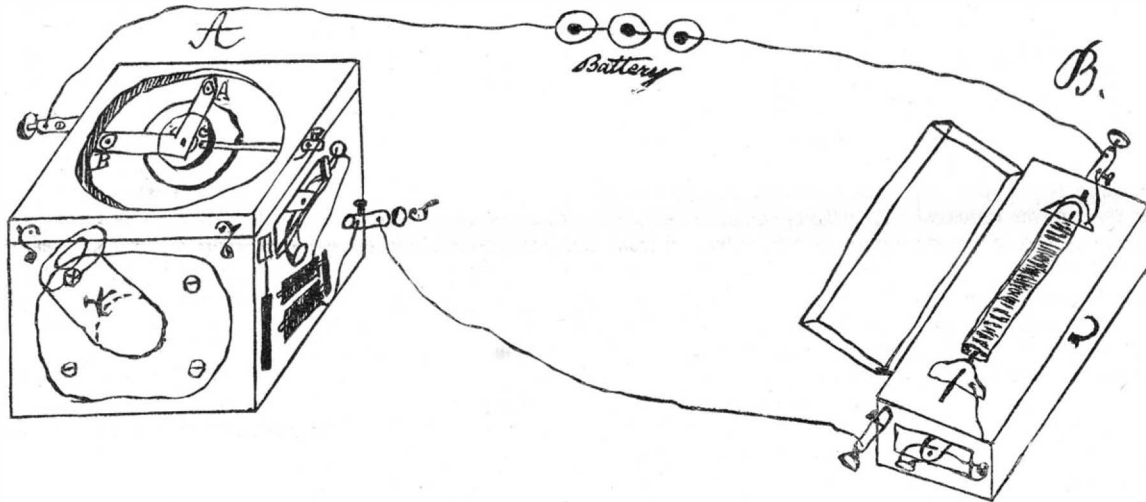

SKETCH OF THE FIRST TELEPHONE, AS MADE BY THE INVENTOR.

these were the principles which guided me in my invention; they were sufficient to induce me to try the reproduction of tunes at any distance. It would be long to relate all the fruitless attempts I made until I found out the proportions of the instrument and the necessary tension of the membrane. The apparatus you have bought is now what may be found most simple, and works without failing when arranged carefully in the following manner:

The apparatus consists of two separate parts, one for the singing station, A, and the other for the hearing station, B. The apparatus, A, is a square box of wood, the cover of which shows the membrane, b, on the outside, under glass. In the middle of the latter is fixed a small platina plate, to which a flattened copper wire is soldered, on purpose to conduct the galvanic current. Within the circle you will further remark two screws; one of them is terminated by a little pit in which you put a little drop of quicksilver, the other is pointed. The angle, which you will find lying on the membrane, is to be placed according to the letters, with the little hole, a, on the point, a, the little platina foot, b, into the quicksilver screw, the other platina foot will then come on the platina plate in the middle of the membrane.

The galvanic current coming from the battery (which I compose generally of three or four good elements) is introduced at the conducting screw near b, wherefrom it proceeds to the quicksilver, the movable angle, the platina plate, and the complementary telegraph to the conducting screw, s. From here it goes through the conductor to the other station, B, and from there returns to the battery.

The apparatus, B, a sonorous box, on the cover of which is fixed the wire spiral with the steel axis, which will be magnetic when the current goes through the spiral. A second little box is fixed on the first one, and laid down on the steel axis to increase the intensity of the reproduced sounds. On the small side of the lower box you will find the corresponding part of the complementary telegraph.

If a person sing at the station, A, in the tube, x, the vibrations of air will pass into the box and move the membrane

above, thereby the platina foot, c, of the movable angle will be lifted up, and thus will open the stream at every condensation of air in the box. The stream will be re-established at every rarefaction. In this manner the steel axis at station B will be magnetic once for every full vibration, and, as magnetism never enters or leaves a metal without disturbing the equilibrium of the atoms, the steel axis at station B must repeat the vibrations at station A, and then REPRODUCE THE SOUNDS WHICH CAUSED THEM. ANY SOUND will be reproduced, if strong enough to set the membrane in motion.

The little telegraph which you find on the side of the apparatus is very useful and agreeable for to give signals between both of the correspondents. At every opening of the stream, and next following shutting, the station A will hear a little clap, produced by the attraction of the steel spring. Another little clap will be heard at station B, in the wire spiral. By multiplying the claps and producing them in different measures, you will be able, as well as I am, to get understood by your correspondent.

I am to end, sir, and I hope that what I said will be sufficient to have a first try; afterward you will get on quite alone.

I am, Sir,

Your most obedient servant,  
PH. REIS.

FRIEDRICHSDORF, 13, 7, '63.  
To Mr. WILLIAM LADD.

#### An Electrical Street Car.

The Electrical Power Storage Company, London, has recently built a street passenger car worked by electricity. This car was constructed at the company's works at Millwall, and is of the usual dimensions for carrying forty-six inside and outside passengers. It weighs with its accumulator and machinery, but without any passengers, 4½ tons. Under the inside seats of this tramcar is placed the accumulator, consisting of fifty Faure-Seillon-Volekmar cells, each measuring 13 inches by 11 inches by 7 inches, and each

weighing about 80 pounds. This accumulator, when fully charged, is capable of working the tramcar with its maximum load for seven hours, which means half a day of tramway service.

From the accumulators the current is communicated by insulated wire to a Siemens dynamo placed under the car, and which acts as a motor, the motion being transmitted to the axle of the wheels through a driving belt.

To start the car the current is switched on from the accumulator to the dynamo, the armature of which being set in motion, the power is communicated to the driving wheels. The car can be driven from either end, and the power required can be exactly apportioned to the work to be done by using a greater or

lesser number of cells. On a level road, for instance, with a light load, only a comparatively small number of cells will be necessary, but with a heavy load or on a rising gradient greater power will be required, and additional cells must be switched in.

The action of the motor, and consequently the direction of the car, can be readily reversed by reversing the current, and the car can also be as readily stopped by shutting off the current entirely, and applying the hand brake with which the car is fitted. At night the car is lighted by means of four Swan incandescent lamps, two of which are placed under the roof and one at each end of the car. All the lamps derive their current from the accumulator. The car is also fitted with electric bells, worked from the same source. With regard to the all important question of expense, it is stated that the actual daily cost of horsing a tramcar, as given by some of the metropolitan companies, is £1 6s, while that of electrical power is put at 6s. 3d. The question of first cost, it is said, need not here be taken into consideration, inasmuch as it is almost identical in each case. Electricity, however, would appear to have the advantages of requiring less space and a smaller working staff, while the machinery would be exempt from those epidemics which may at any time incapacitate the stud of a tramway company.

THE *Railway Age* publishes a summary of railway construction in the United States for the year 1882. The account covers only the main track, and shows the construction in States and Territories. On 342 lines the aggregate is 11,343 miles, or about 2,000 miles more than in 1881, which exceeded any previous year by 2,000 miles. The construction is divided as follows: Five New England States, 53½ miles; four Middle States, 1,315½ miles; five Middle Western States, 2,077½ miles; eleven Southern States, 1,490½ miles; four in Missouri River belt, 2,063½ miles; five in Kansas belt, 2,157¼ miles; five in Colorado belt, 1,165 miles; six in Pacific belt, 1,020 miles.

## Correspondence.

## Electricity in Printing Presses.

To the Editor of the Scientific American:

I have considerable trouble with electricity, which gets into the paper as it passes through my cylinder printing press. If I have a small quantity of highly calendered sheets to be printed on both sides, when I run the blank sheets through there is no electricity in them; but as they pass through, the cylinder—I judge—generates the electricity and imparts it to the sheet being printed, and when the sheet comes out it is sometimes so charged that it adheres to the other sheets, causing an "off-set;" and the electricity does not leave the sheets for some time, thereby interfering with the feeding of the sheet the second time through.

Several plans have been tried in this and other printing offices, such as oiling and chalking the tympan, running a copper wire underneath the paper and into a pail of water, and numerous other ways have been resorted to, to remove the difficulty, but with no success. Can you suggest a plan whereby the electricity can entirely be removed?

Chicago.

[ANSWER.—The same difficulty that our correspondent speaks of is experienced in many other printing offices. In a dry atmosphere, in buildings where the floors are insulated by dry timbers, electricity will be abundantly generated when non-conductors such as belts or sheets of paper are put in motion. The most effective remedy is to produce a damp atmosphere in the room or shop.

This may be done by thoroughly wetting the floor with water. In the printing rooms of the SCIENTIFIC AMERICAN it is found that sponges saturated with water and placed on the fly table serve a good purpose; and our printer has proposed to use pans of water having perforated covers, for the same purpose. In damp weather the electricity does not make its appearance.]

## The Loon.

To the Editor of the Scientific American:

While on Lake George last summer, I observed an interesting trait in the loon, which may be set down to the credit of the species.

Returning one evening to our camp in the "Narrows," and threading the islands which add so much to the beauty and attraction of that part of the Horicon, we suddenly reached an open space where, immediately ahead, I observed a family of loons disporting themselves in the water. They had evidently sighted us first, and for a short time appeared to be discussing the situation, but their resolve was quickly made and speedily executed. My companion had followed a suggestion to measure our paddles with theirs, although we knew that to pursue them in a boat, if not a wild goose chase, was something even more hopeless, and expected they would dive and make off in the usual manner. Their tactics were, however, somewhat different on this occasion, as they had their young to look out for.

When we were well on their track all disappeared simultaneously, and shortly after the mother-loon came up with her young in the middle of the lake, and began sculling rapidly to the opposite shore, but, wholly to our surprise, paterfamilias rose to the surface in his former position, and there awaited our approach.

On the impulse of the moment I sent a few shot after him when about a dozen rods off, but fortunately they only ruffled the water where he had disappeared, and in a moment he was up again uninjured. Instead of retiring at this signal, as might have been expected, he rather assumed the offensive, and appeared to challenge assault by coming nearer and occasionally giving an ironical laugh.

He continued about our boat, sometimes within oar's reach, for several minutes, diving spasmodically and immediately returning to the surface as if he had made some mistake. Whenever he balked us successfully, he celebrated the event by uttering a peculiar and unearthly sort of howl, more like the deliberate yell of some wild beast than the cry of any bird.

He was evidently sacrificing himself for the safety and preservation of his young and mate, as he must have known, if his ruse worked, it would be at extreme personal risks. While keenly watching us, I noticed that he had also an eye to his little family, which was evidently the object of his chiefest solicitation, and was now nearing the western shore.

The two young presented an interesting sight, swimming side by side in front of the old bird, and probably also at her direction. As was somewhat singular, we did not get a glimpse of them, after they first disappeared, until they were well over to the opposite side. By what chicanery they were concealed I do not know; when well out of harm's way there was a reunion, and loud and long was the laughter of the whole family.

This strong instinct, which prompts a bird to preserve its offspring at all hazards to itself, is always admirable. In such cases, birds which are the slyest under ordinary circumstances become frequently the boldest and most venturesome.

The loon in the water plays a similar role to that of the partridge on land, yet in the case of the latter there is less display of bravado and daring. When the ruffed grouse sometimes spins around before you, mewing and trailing her wings in such *deshabille* that you have to pause for an instant to make out what sort of a creature it is, she usually exposes herself but a few moments in the attempt to bewil-

der you, while her chicks seek the leaves, and then retires to a safer distance.

I have seen the wild duck whirr off and leave her brood, in a small stream, to their own resources, but they disappeared as if a whirlwind had swept them away, finding a cover amid the grass on the banks. The young loon seems to look to his seniors not only for instructions but for actual protection.

Scarcely any bird has learned to avoid man more successfully than this, and few better appreciate the meaning of the gun. Shy of the shore, which he seldom approaches except in the gray of the morning, he maintains himself at a safe distance at all other times. When surprised near the land, he instantly dives and speeds his way under water, like a fish, to the widest and deepest parts of the lake, now and then lifting his black head above the surface to take his bearings. If pursued thither, he maneuvers with great skill, even passing under the boat of his adversary, but always outwitting him in the end.

Before reaching the island where we had encamped, a rain came up which lasted through the night and the two following days. I mention this fact, because on the night before (July 3) the loons had been unusually boisterous. Their wild, demoniac laughter was doubly interesting at this point, where the echoes were several times repeated. The hills and mountains seemed alive with demons.

Wilson, in describing this bird (v. Ornith., *Colymbus glacialis*, L.), says they are particularly restless before a storm, and mentions a shipmaster of his acquaintance who always knew when a tempest was brewing by the cry of these birds, which at such times was unusually shrill. He had also noted this himself, and the present instance would serve either to confirm the observation, or to show a curious coincidence at least.

F. H. HERRICK.

Burlington, Vt., April 5, 1883.

[THE ELECTRICIAN.]

## The Inventor of the Telephone.

SIR: As your editorial note of p. 374 invites me to give the references that I have indicated in evidence of Reis' claim to be the inventor of the telephone, which he designed for the express object of transmitting human speech and other sounds of all kinds, I have much pleasure in giving you the very same references which I have myself obtained from the published writings of Graham Bell ("Researches in Telephony," *Journal of Society Telegraph Engineers*, 1877) and of Edison (see Prescott's "Speaking Telephone," p. 218).

The following are a few of Bell's references:

(1) "Telephonie," *Dingler's Polytechnisches Journal*, clxviii., p. 185, extracted from the *Jahresbericht des Physikalischen Vereins zu Frankfurt am Main*, 1860-61, pp. 57-64.

This is a scientific memoir by Philipp Reis, having for title "On Telephony by the Galvanic Current." On p. 58 he says his endeavor was to find an instrument which should reproduce the total action of all the organs set in action in human speech (menschlichen Sprache), and that he took the human ear as model, because the tympanum of the ear could respond to all sounds. After discussing the problem of representing the pressures of the air in sound waves by a "curve," he says that if it is possible at any place to reproduce vibrations having a similar "curve," the very tones will be reproduced. He then says that, taking his stand on the principles laid down, he has succeeded in reproducing the tones of various instruments, and to a certain degree the human voice (die menschliche Stimme). After describing his instrument—the well known combination of a tympanum in imitation of that of the human ear, with an electric current regulator, consisting of an interrupting apparatus, which embodied the loose-contact principle of the microphone, and which is in many respects exactly like the interrupter in the Blake transmitter—he says (p. 62): "I give to my instrument the name 'Telephon.'" Later on he says that the reproduction of human speech which he has attained is not so clear as to satisfy everybody, and that though the consonants are transmitted distinctly enough, the vowels are not equally so, and he proceeds to discuss why this is the case.

(2) *Bria's Zeitschrift des deutsch-oesterreichischen Telegraphen Vereins*, 1862, vol. ix., p. 125. This article is also reprinted in *Dingler's Polytechnisches Journal*, 1863, vol. clxix., p. 23.

This is a report by Inspector Von Legat on Reis' telephone in its developed form. Inspector Von Legat says that this instrument was able to reproduce single words uttered as in reading and speaking, though not so distinctly as it reproduced chords and melodies, which latter it transmitted with marvelous fidelity. He even added that the inflections of the voice, the modulations of interrogation, exclamation, wonder, and command attained distinct expression!

So much for Bell's references; Edison's reference is the same as No. 2 of the preceding.

As to the publicity of these documents, permit me to refer you to the shelves of the British Museum and other public libraries.

I do not say that there is not plenty of further evidence, were such needed. But here I am quite content to accept the references given by such unimpeachable authorities as Bell and Edison. When they refer me to papers wherein Reis says in substance, "I am the inventor of the telephone. My instrument is intended to transmit human speech and all other kinds of sounds that a human ear can hear, and it succeeds in doing so, though I find to my disappointment that it is not quite yet perfect, because, though single words and consonants come through all right, the vowels are not clear," I

am bound to believe, on the authority of Bell and Edison, who give me these references, that Reis' modest claim is just. And I am bound to this belief still more strongly because I find, when I make careful trial of Reis' own telephones, that they will do exactly what he said they were intended to do—namely, transmit human speech to a distance by the agency of the galvanic current.

You have, Mr. Editor, most aptly said that the question is, What was *the kind of success aimed at* and attained by Philipp Reis? and I entirely agree with you that this question is not in the least degree affected by whether Philipp Reis is dead or alive. Though himself be dead, and the task of defending his memory from outrage fall to others, his words still live to testify in the most unmistakable manner to the aim which he set before himself, and to the measure of success which he attained in his invention of the telephone.

Yours, etc.,

Bristol, March 4, 1883.

SILVANUS P. THOMPSON.

## Waste Products Utilized.

We all know something of what is doing in the way of utilizing materials which have commonly been regarded as useless. With the growth of the world and the steadily increasing and remorseless demand upon the long established sources of supply comes the urgent need of something to make up for this depletion. In response to this need we have paper made from wood instead of from rags, colors made from the refuse of the gas house instead of from natural products, and so on. These are hints at the more commonly known forms of substitution.

There was a time when in wire factories the dilute sulphuric acid, formerly used to clean the wire, was allowed to run into the sewer when it had become so charged with the iron scale as to cease to "bite," and large quantities of refuse wire were employed only to fill up hollows in grading, or thrown into a heap. All this waste material is now, however, converted into articles of commercial value. The first product is copperas. Even the waste of this product from waste is utilized. The settlings of the boiling tank—oxide of iron—together with the waste copperas, an alkali, and an inexpensive substance to give "body," are roasted, ground, and converted into a pigment quite equal to imported Venetian red.

It is well known that heaps of refuse, or "tailings," as they are technically termed, accumulate where mining operations are carried on. The sludge which is emptied from the puddling mills in Australia contains a considerable quantity of fine gold. Much of this is now recovered, and the yield of gold from these exceeds three hundred-weight per ton. After a large gold coinage at the Royal Mint, there is always a great deficiency in waste and sweep. The sweep is composed of cinders or dust from the forge, the sweepings of the workshops, broken crucibles, the dross which adheres to the ingots of metal after fusion, and of every waste which can possibly contain minute particles of the metal. This is generally sold. The silver and gold from photographers' waste is also now carefully collected, and form a considerable item in economy. A method of utilizing the waste of gold leaf used in printing and the arts is by converting it into what is called fleecy gold. The composition is used like the ordinary bronze, except that rather more copal is mixed with it. It is used for all fancy papers for which gold leaf and bronze have hitherto been used.

A lecturer before the famous Society of Arts refers to still other movements in this same direction. The waste of the glass furnaces, such as pieces of broken glass, flaw glass, the hearth droppings, and the glass remaining adherent to the blower's pipe, is utilized again, serving a purpose in the manufacture of glass similar to rags in paper making. Agate glass is made by melting waste pieces of colored glass. Broken bottles are now collected and utilized. Broken "wines" and broken "sodas" are converted to many useful purposes, the latter especially. The broken bottles are utilized for the manufacture of cheap jewelry, chimney ornaments, and inferior household glass for the manufacturing districts. They are also used for the manufacture of emery powder, glass paper, etc.

There can be little doubt that the people of the future will live and thrive and grow rich by putting to practical use the things which the people of the present throw away.

To the above, compiled from various sources by one of our contemporaries, might be added many other products which modern chemistry and invention have produced from heretofore useless dirt heaps. One of the latest of these savings is the treatment by naphtha of iron filings and the cotton waste of machine shops, by which the oil is separated and sold, and the cotton waste is cleaned and restored for use again.

## The Usefulness of the Scientific American.

A valued correspondent sends in his usual subscription, and writes us as follows:

I have been a regular subscriber for the SCIENTIFIC AMERICAN from vol. iv., old series, and have the whole, bound and on file unbound, except first volume, old series; and, although I am now on the last quarter of the sixty-ninth year of my age, I still consider it interesting and profitable to peruse the pages of "Old Sci." It has truly been an educator to me, and, no doubt, the same to many others. Long may it live and prosper, and in the future, as in the past, contribute its due share in the enlightenment and improvement of mankind.

G. W.

Hamburg, Erie Co., N. Y.

**A Compressed Air Locomotive.**

What is undoubtedly the first practical attempt to use compressed air as an underground motor in a coal mine in this country is meeting with success at the Old Eagle pits of W. H. Brown Sons, 27 miles up the Monongahela above Pittsburg. The new motor was built at the Baldwin Locomotive Works, and is a most singular looking affair. The available height above the pit rails being only 5 feet 10 inches, the air locomotive had to conform thereto. The air receivers are 27 feet long and 38 inches in diameter, and made of sheet steel. These are filled with air compressed to 400 pounds per square inch, forming the actuating power of the machine. These air receivers rest on four wheels, driven by a pair of locomotive cylinders, gearing, etc., just as in a railway engine, the air taking the place of steam. The originator of this idea, Capt. Harry Brown, expressed himself as more than satisfied with this locomotive. It does the work of a score of mules, requires the attention of only one man—who also operates the air compressing machinery—and can haul 55 loaded cars (60 tons) up a gradient of 100 feet to the mile.—*Coal Trade Journal.*

**New Method of Printing a Positive from a Positive.**

MM. Cros and Vergeraud have worked out a process for obtaining images so as to have a positive impression from a positive plate, and a negative print from a negative original. The process is based on the following circumstances: The easy reduction of soluble bichromates mixed with certain organic substances, and the relative insolubility of bichromate of silver. Suitable paper is covered with a solution of two grammes of bichromate of ammonia, and fifteen grammes grape sugar, dissolved in 100 of water; when dry, it is exposed to light under a positive. As soon as the yellow paper becomes gray, it is removed, and immersed in a one per cent silver bath, to which ten per cent of acetic acid has been added. The image will immediately appear of a ruddy hue, due to the bichromate of silver. The print, on being washed, retains the red impression of the insoluble bichromate, which becomes dark brown on exposure to sunlight. On submitting the print when dry to the fumes of sulphureted hydrogen, or dipping in a solution of sulphite of copper and potash, it becomes black. The latter process is preferable.—*Photo. News.*

**MACHINE FOR MEASURING TEXTILE FABRICS.**

To measure textile fabrics correctly by a machine is far more difficult than many people would suppose. The difference may be unimportant in the case of calico or other equally unelastic goods, but where woolen goods are concerned, which can be pulled out considerably by a slight stretching, the difference between the measurement of one person and another is sometimes serious. For this reason it is also customary to measure all goods with an elastic selvage down the middle, even when they are not doubled, as naturally the selvages stretch more than the body of the cloth.

In mills where large quantities of goods have to be measured, this is nowadays generally done by machinery. Very often the measuring arrangement is in conjunction with a plaiting or rigging machine, and the number of plaits or layers is registered, the division of a whole plait being thus roughly taken from an index, or the goods pass over a roller covered with cloth or baize, which is in connection with a dial, and is turned by contact with the passing cloth. But even here the measurement is not always correct, because in order to secure adhesion to the roller there must be a certain drag, and this means, of course, a stretching of the cloth.

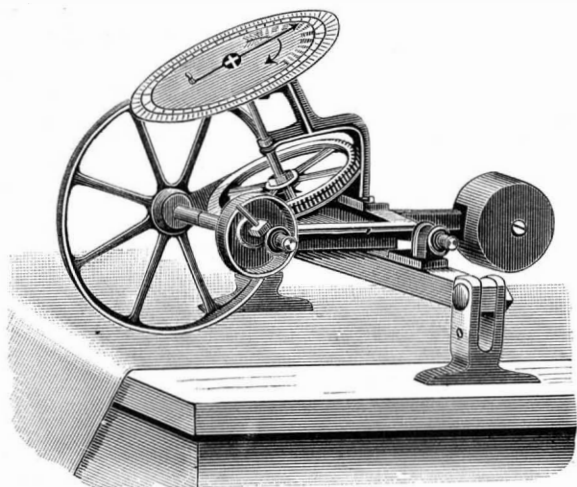
**MACHINE FOR MEASURING TEXTILE FABRICS.**

Smaller quantities of goods, especially of the more valuable ones, can be measured more correctly in other ways, and our illustration shows an appliance for the purpose.

Here the cloth does not pass over a roller, or has to drag a heavy cylinder, but is simply drawn by hand or by power over a table. This can be done without exerting any drag upon the cloth. A light iron pulley runs over it, and is turned by the passage of the cloth. This pulley, whose axle runs in two small standards placed upon the table, is connected in the usual manner with a dial, upon which the number of revolutions or yards, or any other standard measure, is registered, while the subdivisions of the same are indicated by a finger and small pulley, the latter of which is keyed direct upon the shaft of the larger pulley. In order

to obviate the least drag of the cloth upon the pulley, the latter is counterbalanced by a weight, which can be shifted according to the adhesiveness required. The little machine appears simple, and will no doubt measure correctly if well made.—*Textile Manufacturer.*

**IMPROVED FIRE ESCAPE.**

The engraving shows a fire escape in which a carriage is arranged to run upon a track near the top of the house. It is provided with a pendent ladder, and may be moved along the track by an endless rope and chain and chain pulleys in one direction or the other, for the purpose of bringing the ladder opposite a window, door, or other place of escape.

A horizontal rail is attached to the building beneath the

**COPELAND'S FIRE ESCAPE.**

cornice, and supports a carriage, which consists of a U-shaped frame mounted on grooved or flanged wheels, that travel on the rail.

An endless rope passes over grooved pulleys journaled in the frame, and an intermediate pulley which is journaled in the lowest part of frame.

A chain pulley is mounted loose on the projecting axis of the lower rope pulley, and may be locked thereto by means of the spring clutch, which is fixed on the axis, and operated by a lever and hand rope extending to the ground.

An endless chain connects the lower chain pulley with the upper pulleys, which are fixed on the same axis as the flanged transporting wheels.

By pulling the hand rope the lower chain pulley and rope pulley will be locked together; then, by pulling the endless rope in one direction or the other, the carriage will be propelled on the rail in a corresponding direction. It is within the power of any person, stationed on the ladder hanging from the carriage, or on the ground, to propel the carriage and its attachments along the rail to any desired point, and thereby render the ladder available for convenient and immediate use. The ladder furnishes the chief means of escape, but a clamp, which is attached to the endless rope, can also be used as means of escape.

To render the movement of the endless rope uniform during the descent of a person on the endless rope, and at the same time automatic, an automatic governor is provided, which retards the descent and renders it uniform.

The entire fire escape apparatus, with the exception of the rail, which is a fixture, may be inclosed in a suitable box or casing on the rear side of the building, where it will be out of observation and protected from the weather, as well as from access of thieves or burglars designing to enter the building.

By constructing the box or casing with a door properly arranged, the carriage, ladder, and other attachments may be moved out at once when required for use, and guided to the desired point.

To allow the escape to travel around a corner to a different side of the building, the supporting rail is curved, and the flanged supporting wheels are made with a tread wide enough to accommodate the curve.

Further particulars may be obtained by addressing Mr. F. A. Copeland, La Crosse, Wis.

THE Commissioner of Patents has recently decided that in interference cases before the Patent Office, to determine who is the prior inventor, the wife of either contestant may appear as a competent witness.

**Oil of Wintergreen in the Treatment of Acute Rheumatism.**

Dr. F. P. Kinnicutt draws the following conclusions from the results obtained in twelve cases of acute rheumatism, treated by oil of wintergreen:

1. In the oil of wintergreen we possess a most efficient salicylate in the treatment of rheumatism. 2. In its efficiency in controlling the pyrexia, the joint pains, and the disease, it at least ranks with any of the salicyl compounds. 3. The best method of its administration is in frequently repeated doses, continued in diminished doses throughout the convalescence. 4. Its use possesses the advantages of being unattended with the occasional toxic effects, the frequent gastric disturbance produced by the acid or its sodium salt, even when prepared from the oil of wintergreen; that its agreeable taste, and finally its comparative cheapness, are further recommendations in favor of its employment.

**ELECTRO PULVERIZER AND AMALGAMATOR.**

The Manes electro pulverizer and amalgamating machine, shown in the cut, is designed for saving the rusty and fine gold, also the quicksilver, that has been lost in hydraulic washing for gold on the coast of California ever since the commencement of hydraulic washing in the summer of 1852. It is said that the loss has been at the rate of from 20 to 35 per cent of the precious metals and mercury, which, if saved, would amount to hundreds of millions of dollars.

Notwithstanding all the modern improvements in mining machinery, immense quantities of the precious metals are constantly washed away and irrecoverably lost. The value of this lost portion, according to various estimates, is very nearly if not quite as great as that of the metal secured. A great deal of engineering skill and inventive genius have been engaged in trying to devise means of preventing this great loss. This has generally resulted in placing various devices in the sluices to catch and retain the stray particles of gold or sulphuret. Some of these inventions have been more or less successful, but none of them have saved anything like a reasonable proportion of the valuable part of the metals.

The electro amalgamator, it is claimed, will save from 50 to 75 per cent of all the gold and quicksilver that passes through the machine, as the rusty gold will be perfectly scoured and electroplated with quicksilver, and thoroughly amalgamated by the rapid action of the electrical steel brushes and steel mullers that revolve inside of the series of steel cylinders in the machine, placed one above the other, and made cone shape, and connected with spouts; the large end of one cylinder is placed under the bottom of the small end of the next one and so on, forming inclined planes for the sand or crushed ore to run down by its own gravity, which is assisted by streams of water and quicksilver, constantly fed into the machine from a hopper on the upper part of the machine; and the powerful current of electricity is constantly passing through the sands or ore, as it passes from one cylinder to another, and as it is thoroughly mixed at the same time with the quicksilver by the steel brushes, no gold escapes without having been thoroughly amalgamated. The material passes through a movable iron spout into settling tanks, where the cleaning up is done. The machine does not stop except when repairs are needed; the waste water of the sluice boxes is used for driving the machines, and but one

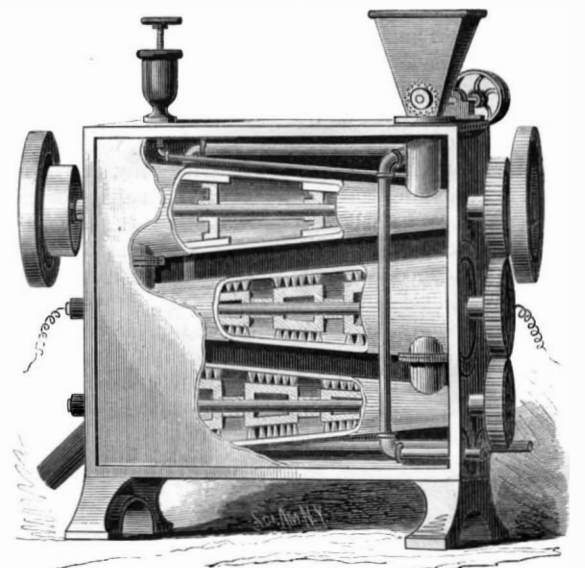
**MANES' ELECTRO PULVERIZER AND AMALGAMATOR.**

man is required to attend to each machine. The fine sands will be conveyed into the machines through screens of the proper size. This apparatus can be used in stamp mills for amalgamating purposes, and will surpass the old process of treating gold and silver ores. The inventor, Mr. James Manes, is now engaged at the new chemical works in Morrison, Jefferson County, Colo., for the Colorado Paint and Chemical Company, as chemist and metallurgist. Mr. Manes, as an inventor of mining machinery, is well known in this and other countries. The first one of the electro amalgamating machines has just been completed at the extensive shops of the Colorado Iron Works, Denver, Colo., and the models and complete drawings are exhibited at the office, 5 Windsor Block, Denver, Colo.



**Peter Cooper.**

The departure of Peter Cooper was the peaceful close of a memorable life. If ever the contemplation of death can be not merely without terror, but even without pain, it is in such a case as this, where, surrounded by the loving circle of children to the third and fourth generations, and by hosts of warm personal friends, loaded with well earned honors, and cheered with the enthusiastic affection of the civilized world, a man who has done great things for his kind goes in the ripeness of age to his rest and reward.

Peter Cooper had long outlived his proper contemporaries; and this generation, which knew him best as a benefactor, had never known him as a bold inventor and enterprising pioneer in great business adventures—still less as an industrious mechanic, practicing a patient perseverance and a frugal economy which seem nowadays to have gone somewhat out of fashion. It is hard to realize that his life covers nearly the whole history of the United States. Born in the middle of Washington's first presidential term, when the population of the country was about 4,000,000 souls, he lived to see it the most powerful of Christian nations, containing more than 53,000,000 inhabitants, triumphant over internal rebellion, fearless of foreign foes, and filled from one ocean to the other with appliances of science and monuments of human skill not dreamed of in his boyhood. Except the stationary steam engine, which had just begun to be generally used when he was born, Peter Cooper witnessed the inception and growth of all the great material improvements which make our modern life what it is. Many of them, notably the railway and the telegraph, he essentially assisted in the days of their feeble beginnings; and his characteristic attitude toward them all was one of encouragement and hope. He was an optimist of the most wholesome type, not believing that things were well enough as they are, but full of a sublime faith that things can be bettered, and ready to welcome with sanguine support all attempts to better them.

In this, as in many other particulars, the history of Peter Cooper is distinctively American. No other country, in the early years of this century, could have given free scope to the versatile ingenuity and unconquerable perseverance with which he turned from one trade to another, until he planted his foot upon the road to fortune. Under other institutions, he would have remained a hatter, like his father, or become a brewer or a coach maker, after once beginning in either of those trades.

But in this free atmosphere he was able to follow each path that offered itself, to master each business that he undertook, and to leave it for another that promised larger scope. He failed in nothing; each step was an advance; and when at last he took up the manufacture of glue and isinglass, the principal occupation of his life, he pursued it with an unwearied and unconquerable ardor as truly American as his versatility.

Another peculiar feature of his career was his conception of the uses and duties attached to wealth. He felt bound by the very fact of his prosperity not only to relieve the unfortunate, but also to organize agencies which should permanently benefit the city, the growth of which had been the basis of his own success, and the working classes, by whose co-operation all great fortunes are built up. The absence of governmental endowments for charity and for learning has always rendered the claims of these objects upon individual generosity stronger in this country than elsewhere. Public spirit has done among us more than official action could have accomplished; and this spirit, fostered by our political system, has gathered strength through the inspiration of great examples, among which that of Peter Cooper is one of the most conspicuous, and has been perhaps the most fruitful.

Notable as have been the results directly flowing from his beneficence, they are insignificant compared with the indirect consequences of the noble contagion which his enthusiasm communicated to other men. It is impossible to measure the effect of his example, showing as it does both sides; the joy and potency of a wise benevolence, and the immediate reward which it commands in the affection and praise of all mankind.

We had intended, in commencing this article, to emphasize particularly Mr. Cooper's earlier achievements, and their relation to the progress of the arts. But goodness is more than greatness; and we feel that the universal feeling is right when it mourns to-day the departure, and rejoices in the history, not of the ingenious inventor, the successful manufacturer, or the enterprising capitalist, but of the lover of men, whose wisest schemes, like his most trivial acts and words, uttered his inmost disposition. The Cooper Union, planted by his hand, and tended with daily assiduity by him to the last, bears in every part the indelible marks, not merely of the man's wisdom or philanthropy, but of the man's self. As his benign face has been for years a most frequent and familiar object within its walls, so his gentle soul pervades and inhabits it forever.—*R. W. Raymond, Eng. and Min. Jour.*

ALPI, the highest mountain in the Philippines, is 10,824 feet high. Only recently has it been ascended by explorers.

**A HAIRY CHILD.**

The picture is that of a girl, six years of age, covered from head to foot with soft, silky hair. Upon first sight little Kra-o, as the child is named, would appear to be the "missing link" between the ape and man, but a closer examination of this peculiar being will prove that this diagnosis is faulty in all respects. We have simply an excellent type of hypertrichophraxis (superabundance of hair), cases of which have been known in this and previous centuries. Kra-o, who is being exhibited in London at present, is quite an intelligent child, and has acquired enough knowledge of the English language within a few months to be able to make herself understood; and this is an ample proof that, although her outward appearance is that of an animal, she has a bright mind and considerable intelligence. A correspondent of the *Institution Ethnologique*, Mr. H. Kaulitz-Jarlow, writes as follows to the editor of the *Illustrirte Zeitung*:

"Kra-o is about six years old; she is of the same size as other children of her age, but of a finer build; thick, jet black hair covers her head and reaches down to the backbone, and forms a perfect mane on the shoulders; the eyebrows are wide, glossy, and silky, and the eyes are of a deep black with open pupils, and the iris is missing entirely, as in the gorilla; the resemblance to the face of the latter is very great and astonishing; the nose is flat, and has wide nostrils inclined diagonally toward the cheek bones; the cheeks hang down and are baggy, and in them Kra-o stores her food and carries it about with her in the same manner as her cousins of the ape tribe.

Her head, like the human type more than any other part of her body, and the intelligent eyes, the agreeably rounded mouth with the full lips, which can smile very pleasantly

**HAIRY CHILD FROM BORNEO.**

when Kra-o plays and talks, do not at all correspond with the ape-like body of the child. Kra-o is of a brownish-yellow color, and the hair extends from the crown of her head to the soles of her feet. She is generally very jolly, loves to play, and is more thankful than most children if persons take the trouble to amuse her. If she is molested and teased, her wild nature shows itself; she throws herself on the ground, screams, strikes the person, and finds great pleasure in tearing out some of her superabundance of hair."

We must call the attention of our readers to the fact that the above is only an extract from a letter from Mr. Kaulitz-Jarlow, who seems to be very enthusiastic in the matter of classifying Kra-o as one of the apes. Kra-o was found in the presence of her parents in the Loas district, in Borneo. Her father died while traveling to Bangkok, and her mother is at present at the court of the King of Loas. Mr. Karl Bock brought the child to England, and it is now exhibited by Mr. Jarini.

**Bakuol, a Safe Illuminating Oil from Baku Petroleum.**

The introduction of the oils of the Caucasus into commerce naturally attracts much attention in Europe, but more especially in Russia. That their composition is not precisely like that of American petroleum was ascertained a few years ago, and is still further illustrated by the following report of Professor Mendelejeff, president of the Chemical Society of St. Petersburg, upon the preparation of a safe illuminating oil, not flashing below 50° C. (122° Fah.), from Baku naphtha.

Mendelejeff says that by mixing ordinary Baku kerosene,

which has a gravity of 0.82 or 0.83 and burns between 20° to 30° C. (68° to 86° Fah.), with another product of Baku petroleum called "intermediate oil," which has a gravity of 0.86 to 0.88 and does not take fire below 100° C. (212° Fah.), a safe oil can be prepared, using them in the proportions in which they occur naturally, namely, 2 or 3 parts of the former to 1 or 2 parts of the latter. This mixture has a specific gravity of 0.84 or 0.85, and fills all the requirements of an illuminating material free from danger, as it takes fire only between 50° and 70° C. (122° and 158° Fah.). Since such a mixture burns well in the ordinary kerosene lamp, it can be recommended as an excellent illuminant.

The crude petroleum from the Caucasus yields from 20 to 30 per cent of the lighter oil above described (called over there kerosene) and 10 to 20 per cent of the "intermediate" or heavier oil. By the utilization of the described mixture a much larger portion of the petroleum product becomes available for illumination, which would result in reducing its cost.

Mendelejeff proposes the name of "Bakuol" for his new mixture.

[Mixing the oils of high and low flashing points from American petroleum has a very different effect, namely, that of reducing the flashing point of the mixture to a dangerously low point.—Ed.]

**The Aim of Exercise.**

It should be understood by the public, as it is known to the profession, that the aim of exercise is not solely to *work* the organism which is thrown into activity, though that is one, and a very important, part of the object in view, because as the living body works it feeds, and as it feeds it is replenished; but there is another purpose in exercise, and that is to call into action and stimulate the *faculty of recuperation*. Those who believe in the existence of a special system, or series, of trophic nerves will not object to this designation of the recuperative function as a separate "faculty," and those who believe nutrition to be effected in and by the ordinary innervation will recognize the sense in which we employ the term in italics. It is through defect or deficiency in the vigor of this faculty that unaccustomed feats of strength, whether of mind or muscle, are found to be exhausting.

The task is performed, but the underlying faculty of restorative energy, or power of recuperative nutrition, located in the particular part exceptionally exercised, is not in a condition to respond to the unusual call made upon it. When a man goes into training, or, which is practically the same thing, when he habituates himself to the performance of a special class of work, he so develops this recuperative power or function that the repair or replenishing necessary to restore the integrity and replace the strength of the tissue "used up" in the exercise is instantly performed.

The difference between being accustomed to exercise and able to work "without feeling it," and being barely able to accomplish a special task, and having it "taken out" of one by the exploit, whether mental or physical, is the difference between possessing the power of rapid repair by nutrition, and not having that power in working order—so that some time must elapse before recovery takes place, and during the interval there will be "fatigue" and more or less exhaustion.

The practical value of a recognition of this commonplace fact in physiology will be found in the guidance it affords as to the best and most

direct way of developing the power or faculty of recuperation by exercise. Many persons make the mistake of doing too much. Exercise with a view to recuperation should never so much exceed the capacity of the recuperative faculty as to prostrate the nervous energy. The work done ought not to produce any great sense of fatigue. If "exhaustion" be experienced, the exercise has been excessive in amount.

The best plan to pursue is to begin with a very moderate amount of work, continued during a brief period, and to make the length of the interval between the cessation of exercise and the recovery of a feeling of "freshness" the guide as to the increase of exercise. We do not mean that false sense of revival which is sometimes derived from the recourse to stimulants, but genuine recovery after a brief period of rest and the use of plain nutritious food. If this very simple rule were carried into practice by those who desire "to grow strong," there would be less disappointment, and a generally better result, than often attends the endeavor to profit by exercise unintelligently employed.—*Lancet.*

**Chlorine as Plant Food.**

A German exchange says that chlorine is a very important nutrient for plants. To all appearances the chloride of potassium exceeds the nitrate in nutritive value as long as the quantity does not exceed a definite limit. When there is too much of the chloride, the quantity of chlorophyll decreases, the plants ripen sooner, but the oxalic acid increases in quantity. In fact, it acts just like hydrochloric acid would.

### RECENT INVENTIONS.

#### Improved Butter Case.

The engraving shows a butter case provided on two of its opposite sides with vertical sockets for the reception of handles adapted to slide up and down in the sockets. The transportation case is made with one or more partitions separating the interior into cells in which to place the butter tubs or cases. The latter are made of metal, glass, porcelain, stone, or other material that the butter will not destroy. The cover of the outer case is hinged to it, and provided with rubber cushions on the inside to press down on the covers of the butter cases when it is closed and fastened, so as to confine the butter cases and prevent them from shaking about in transit. The butter case covers close over the tops of the cases, and the cases are provided with sliding handles at the sides for lifting them. The butter cases are surrounded by air spaces between them and the walls of the outer case, which protect the butter from the heat while in transit and while the outer case is exposed to the sun. This invention has recently been patented by Messrs. F. Leete and W. C. Wilbur, of Mapleton, Ia.

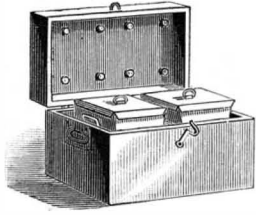

#### Improved Elevator.

The annexed engraving represents an improvement in elevators recently patented by Mr. William Goddard, of Chester, Ill. The principal feature of the improvement is the arrangement of serrated cams that are arranged to grip the uprights in case of the breakage of the lifting chains or ropes. These cams are fixed to the opposite ends of two shafts extending over the top of the elevator car and on opposite sides of the uprights. The shafts are provided with levers for receiving the lifting chains or ropes, and the levers are placed relative to the cams, so that when the car is being supported by the ropes or chains the cams are held out of contact with the uprights, but when the ropes give out a spring connecting two arms of the shafts brings the cams into engagement with the uprights and arrests the car. This is very simple in its construction, easily applied, and certain in its operation.

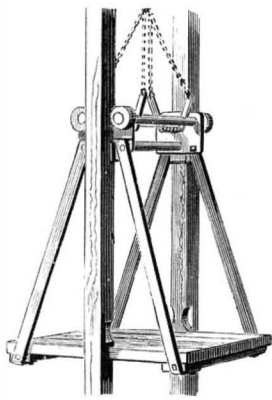

#### Traction Wheel.

The engraving shows a novel endless track wheel rim for application to wagon and traction engine wheels, when being used on soft ground or roads, the object being to prevent the wheels from sinking in the ground. The improvement consists of a series of planks linked together, forming an endless track of greater length than the length of the rim of the wheel, to enable the planks to drop flat on the ground before the wheel passes on to them. The planks have prongs which straddle the rim of the wheel, to keep them on the rim, and at the same time to allow the requisite movement of the planks relatively to the rim for enabling them to so drop on the ground in advance of the rim, and also to allow the planks to lie flat on sloping ground. The inventor connects one of the joints of the endless track by removable or detachable devices of any approved kind, enabling the track to be disconnected for ready application to and removal from the rim of the wheel, as may be required for putting on the track when the ground is soft and taking it off when the ground is dry and hard. This device has been patented by Mr. Oliver F. Gilbert, of New Haven, Mich.

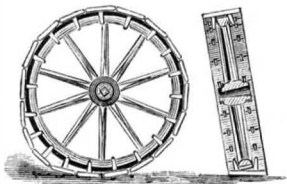

### The Relation between Fluorescence and Chemical Constitution of Organic Bodies.

Why do some substances exhibit fluorescence and others not? This is a problem that must remain for a long time unsolved, and we cannot, at present, expect to answer that question any more than we can tell why sodium sulphate is soluble in water while barium sulphate is not.

In order to approach a little nearer to an understanding of the subject, we must decide to proceed in such a way as to find out what may be called the *statistical* reason, as distinguished from the true and actual cause. This can be accomplished by grouping together known facts and cases so as to see what peculiarities of constitution are common to substances having the same physical peculiarities. This method has been pursued in the numerous experiments made to determine the cause of colors in dyes, and it can also be applied

to the study of fluorescent bodies, of which there are already quite a large number to experiment upon.

Liebermann collected the fluorescent derivatives of anthracene, and thereby arrived at a very remarkable result. Anthracene has the formula  $C_6H_4(CH_2)_2C_6H_4$ , or two groups of  $C_6H_4$  are connected by a pair of carbon atoms, to each of which is attached one of hydrogen; hence these hydrogen atoms (which we have placed in the parenthesis) have an entirely different position from the others. Liebermann found that all anthracene derivatives which contained these hydrogen atoms unchanged, or had them replaced by monad groups, possessed fluorescence. If, however, the CH groups are changed to CO groups, as in anthraquinone, which has the formula  $C_6H_4(CO)_2C_6H_4$ , and its derivatives, the fluorescence is wanting.

The most beautiful and intense exhibition of fluorescence is shown in a substance discovered by Baeyer, and called *Fluoresceine*. It is made from resorcin,  $C_6H_4(OH)_2$ , and phthalic acid,  $C_6H_4(COOH)_2$ , by fusing them together. The new compound may be looked upon as resorcin, in which one of the hydrogen atoms of the  $C_6H_4$  group has been replaced by the residue of the phthalic acid. For brevity we may represent this residue by *Phth*, and write the formula of fluoresceine thus:  $C_6H_3(Phth)(OH)_2$ . It is a brick red powder, and when dissolved in alkalis forms a red liquid which has such an intensely green fluorescence that, viewed by reflected light, one thinks that he sees a glittering green precipitate in the liquid, which was clear by reflected light and of a red color. This peculiarity enables us to utilize the phthalic acid as a delicate reagent for the detection of resorcin. If the slightest trace of the latter is melted with phthalic acid, and the fusion dissolved in alkali, the liquid will exhibit this magnificent fluorescence in the most intense degree.

Orcine is a homologue of resorcin. In constitution it is a resorcin with the hydrogen atom replaced by the methyl group,  $CH_3$ , a methylated resorcin having a formula  $C_6H_3(CH_3)(OH)_2$ . This substance is very similar to resorcin in all its properties and reactions, except in its action toward phthalic acid. It does, indeed, unite with the latter, but the resulting compound has no fluorescence at all. In a free state it is colorless, and its alkaline solution is red both in transmitted and in reflected light.

To ascertain why it was that a substance so similar to resorcin should act so differently in that one respect, Knecht adopted an ingenious method of experimentation. He prepared a substance homologous with resorcin, but having the same chemical composition as orcin, a new isomeric body. This substance, which he called *ressorcin*, has the formula  $C_6H_3(CH_3)(OH)_2$ . It was made from cressol, or methyl phenol, the constitution of which is well known.

Cressorcin, this new isomere of orcin, was found to yield a fluorescent body when melted with phthalic acid, although the new substance had the same chemical composition as the colorless one obtained from orcin and phthalic acid.

The fluoresceine prepared from cressorcin is so similar to that obtained from resorcin that Knecht sought for a long time before he could discover any method of distinguishing the one from the other. Both are brick red powders, soluble in alkali with an astonishing green fluorescence, but by the action of acetic anhydride, acetyl ethers of unlike melting points are produced.

The theory proposed to account for this is that in orcin the  $CH_3$  group occupies the position usually designated as No. 1, and that when this is left free the phthalic acid attaches itself there to form fluoresceine, but that is not possible when this is occupied, as it is in orcin, by a methyl group. The following diagrams exhibit the relative position of the groups on Kekule's benzol ring:

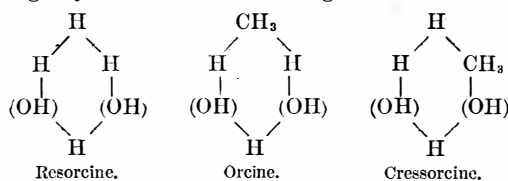

#### Manufacture of Blue Coloring Matters.

R. Meldola's process, according to the *Journal of the Society of Chemical Industry*, is divided into two parts. In the first operation ten parts by weight of the amidonaphthalene sulphonic acid, prepared either by the action of sulphuric acid upon betanaphthylamine, or by reducing the nitro-sulphonic acids obtained by the action of nitric acid upon the betanaphthalene-sulphonic acid, as discovered by Cleve, are suspended in cold water acidulated with muriatic acid, and a solution of nitrite of soda is gradually added in such quantity as shall contain 3.69 parts by weight of pure nitrite. The solutions after being mixed are kept well cooled, and are allowed to stand for some hours, so as to form the diazo-sulphonic acid, or mixture of isomeric acids as mentioned. When the diazotizing operation is complete, which is the case in about two hours, there is added a solution containing 5.4 parts by weight of dimethylaniline, or 6.7 parts by weight of diethylaniline, dissolved in the necessary quantity of muriatic acid, and after standing for some hours the diazo color begins to separate, and is completely thrown out by the addition of ammonia to the mixed solutions.

In the second operation the ammoniacal solution containing the ammonium salt of the diazo color in suspension is mixed with a solution of yellow sulphide of ammonium, and the mixture kept at a temperature of 80° to 90° Centigrade

till the diazo color is completely reduced, as is ascertained by the mixture becoming colorless. The reduction is much hastened by the addition of a small quantity of zinc dust. The solution is now rapidly cooled, and made acid by means of muriatic acid, and the sulphur and amidonaphthalene sulphonic acid thus precipitated is removed by filtration. The solution is then oxidized by ferric chloride, or other suitable oxidizing substances, till the smell of sulphureted hydrogen is destroyed, when the coloring matter at once forms and is precipitated by the addition of chloride of zinc and common salt in the usual way.

The amidonaphthalene-sulphonic acid is freed from sulphur by dissolving it in a weak solution of an alkali, filtering, and precipitating by muriatic acid, and the acid thus recovered can be again used for the manufacture of the blue dye-stuff. The coloring matter precipitated in the manner above described is collected on filters, in order to remove a red coloring matter which remains in the solution, and is purified by dissolving in hot water, filtering, and again precipitating by zinc chloride and common salt. When collected it can be dried, and is then ready for use, or it can be employed in the form of a paste. It is stated to dye silk and wool (from a neutral or ammoniacal bath) of a fine blue shade, and it can be used also for cotton, with or without a mordant, according to the shades required.

#### Hardening Taps and Dies.

A writer in the *Chicago Journal of Commerce* gives his experience in tempering as follows:

The great difficulty in hardening tools is principally their liability to twist or get out of true; second, cracking (especially if large) after hardening; thirdly, getting the right temper. In our factory we use a great number of small taps and rimers; some of the rimers are 9 inches long and a quarter of an inch in diameter; these we harden very successfully, not more than one out of a dozen being out of true. Our plan is as follows: First, carefully select your steel; let it be of the best cast, with a medium grain (a fine grained steel will break when much less force is applied than a coarser grained, and, although it will take a keener edge, it will not resist the strain required by a tap or rimer). Next center it, and turn off the scale and soften. The object of softening after the scale is removed, is to make the grain of the steel equal throughout; if it be softened with the scale on, it will generally cast. To soften, inclose the articles in a piece of gas tube, filling up with wrought iron turnings and plugging the ends with clay, making the whole red hot and allowing it to cool very slowly—*i. e.*, leaving it in hot ashes all night. This method makes the steel very soft, and equalizes the grain. After softening turn up the work, taking care not to bend it or straighten it, should it have cast, as it probably will in the process of softening. The reason for this is that, if the steel be bent or hammered, the grain will be closer in one place than another, and heat has a great tendency to bring it back to its original position. The next thing after finishing your tool is to harden it; first, slightly heat it over a gas or other flame, and rub it all over with a mixture of Castile soap and lampblack. This is to prevent the edges from being burnt. The next is to get a thick iron paper (the size we use is 2 inches diameter and three-fourths bore). This is well filled up with taps or rimers and charcoal dust, the ends being closed with clay as before. This is placed in the furnace and occasionally turned, until it is one uniform heat of cherry red, or on the outside a trifle hotter. It is then carefully removed from the fire, one end of the clay knocked off, and the contents allowed to drop perpendicularly into a solution of water, chloride of sodium, and nitrate of iron: this is kept at a temperature of 60 degrees. The articles hardened should remain at least a quarter of an hour before being removed. This method of hardening may be summed up thus: Make the steel of one grain throughout, prevent it from oxidizing while being heated, allow every part to heat at the same time, avoid bending while hot, and lastly restore, if possible, by adding to the loss of carbon caused by heating. As I have taken up already too much of your valuable space, I will defer the method of tempering to some future time.

#### Dried Leaves as Food for Lepidopterous Larvæ.

Lepidopterists engaged in raising larvæ will be interested in a note by Mr. A. H. Mundt, of Fairbury, Ill., published in *Papilio* for January, 1883, giving his experience in feeding caterpillars with dried food. He gathers the leaves in summer, pressing them quite dry like botanical specimens, and before using them as food he soaks them one night in fresh water. This experiment was successfully tried with the larvæ of *Papilio cresphontes* and *Apatura clyton*. Mr. Mundt adds that the dried leaves must be kept in the dark in order to preserve the green color and the flavor. This experience with preserved food may prove equally useful for other species, and promises to be of great advantage in raising larvæ on food to be obtained from distant sections. We have never tried this method of curing leaves, though we have successfully used pressed fresh leaves, mailed and kept in tight tin boxes. In this way we have fed larvæ for weeks, in Washington, on food obtained in Florida. If "hay making" should prove as successful as Mr. Mundt's experience would indicate, we would recommend, as a possible improvement in the curing and retention of the nutritive properties, the chopping of the leaves, which will permit of more rapid curing and more convenient packing.—*O. V. R., in American Naturalist.*

## MECHANICAL INVENTIONS.

Messrs. E. and H. T. Anthony, of New York city, are the assignees of an invention by Mr. W. H. Lewis, recently granted for a plate holder for photographic cameras, the object of which is to facilitate the insertion and removal of the sensitized plate from the plate holder.

A novel saw mill dog has been patented by Mr. George F. Knight, of Hicksville, O. The invention consists in an apparatus for dogging logs in a very simple and effective manner, and is an improvement on a previously patented dogging device, issued to the same inventor October 26, 1880.

A machine for adding numbers, intended for counting houses, bookkeepers, etc., is the subject of a patent recently granted to Mr. Wm. H. Beatley, of Humansville, Mo. A cylinder is provided within a case, with figures of an almost indefinite number marked on its surface. Finger keys with numbers on them from 1 to 9 actuate the cylinder when pressed upon, similar to the action of a type writing machine.

Mr. Theodore A. McDonald, of New Albany, Ind., is the patentee of a new and improved gauge for rip sawing. The new gauge is intended especially for circular saws used for ripping boards into strips. The distance the gauge bar is moved toward or from the saw is indicated by a graduated bar attached to the gauge bar. The invention is very simple, and evidently a very useful improvement for saw mill owners.

An improved rug making machine has been patented by Mr. Orison Huff, of Goodwin's Mills, Me. The machine relates to the manufacture of rugs in which a piled surface of yarn or worsted is formed upon a backing of canvas or similar material; and the invention consists in novel mechanism for forming the loops or stitches, and for changing the yarn so as to vary the colors.

An improved saw setting and jointing device has been patented by Messrs. Millard E. Beach and Albert Burch, of Cadillac, Mich. At one end of the implement a slot is provided for passing upon the saw teeth in setting them. For jointing the teeth a file is inserted in a slot at the other end of the instrument, and fastened by a set screw, so that the instrument is made to serve as a handle to the file. The invention is very simple, and seems practical.

Messrs. Josiah Austin and Roscoe Chamberlain, of East Liberty, O., are patentees of an automatic double gate which is opened and closed by the pressure of the wheels of the passing vehicle upon a very simple arrangement of devices. The advantage of providing a double gate lies in the possibility of lightening materially the weight of the gates upon the driving gear, which is very important when they are to be operated by the weight of the vehicle solely.

A stop chamfer plane, designed to facilitate the cutting of chamfers of all kinds on the edges of boards, posts, etc., has been patented by Mr. Joseph Lee, of Garnerville, N. Y. The stop chamfer plane is formed of two parallel bevel guides united by adjustable cross rods, and carrying a cutting blade which is locked in position by a binding screw. A transverse gauge is also provided for facilitating the adjustment of the implement.

A machine for renovating feathers is the subject of a patent recently granted to Mr. George F. Tallman, of Deposit, N. Y. A jacket cylindrical case for holding the feathers is provided with steam heated arms, which are made to revolve, stirring up, beating, and renovating the feathers in the most thorough manner. It is claimed that by this machine feathers can be purified and renovated in a better manner than by the machines heretofore used for this purpose.

A delicate scale for weighing diamonds, balance screws for watches, etc., is the subject of a patent issued recently to Mr. Ferdinand F. Ide, of Springfield, Ill. The importance of a simple weighing machine for precious stones and like valuable and delicate articles which shall be weighed accurately is well understood. Mr. Ide, in his newly patented scale, claims to accomplish this, and certainly his mechanism is very simple.

A guard for band pulleys, to prevent accidents from persons' clothing being caught in the shafting, is the subject of a patent granted to Mr. Charles E. Frick, of Cincinnati, O. A cap is fitted over the hub of the shaft and held to it by an elastic band, which is attached to hooks on the inner surface of the cap, and passed around the screw which holds the pulley on the shaft. This guard also protects machinery belts from catching on the screws which fasten the pulley to the shaft.

Messrs. E. and H. T. Anthony, of New York city, by assignment from E. B. Barker, have recently obtained a patent on a photographic camera box, so constructed as to enable pictures to be taken in either horizontal or vertical positions, without moving the lens frame. The same inventor and same assignees as the above have also patented a photographic shield, the novelty consisting principally in a latching device for holding and securing the end gate of a septum in the shield.

An improved machine for sawing match cards has been patented by Messrs. Gilford Flewelling and Gilbert J. Harris, of Hampton, New Brunswick. A disk with a series of holders for the blocks or cards to be sawed, is mounted on slides, which are moved up and away from the saws by a cam device located under the disk. A series of grooving saws, and a series of slitting saws, also a cutting off saw, are so combined and arranged as to enable making match cards in a rapid and expeditious manner.

Mr. William E. Williams, of Dodgeville, Wis., has patented an improvement in windmills, which has for its object to enable rigid wheel windmills to be regulated by the varying force of the wind, and without the use of vanes. By the arrangement of a weighted lever the wheel is forced into the wind as the force of the wind decreases. Vanes can be used for the better control of the wind wheel under certain circumstances, but are used as an auxiliary arrangement to the weighted lever appliance.

An improved pig iron breaker has been patented by Messrs. William R. Havens and John W.

Nesmith, of Denver, Col. A pair of stationary jaws are provided with breaking dies, arranged so as to receive the pigs and hold them between two or more points each side of the middle, while a movable jaw with a single die is made to press against and break the pigs in the most approved manner. The grooves for the breaking dies are so formed that they may be readily removed and others replaced when too much worn.

An improvement designed to facilitate the opening and shutting of a gate has been patented by Mr. Amon W. Chilcott, of Mattoon, Ill. The invention consists of a gate sliding on rollers, and so arranged as to be easily manipulated by elbow levers which project some way on each side of the gate. The gate and its operating mechanism is so constructed that when the gate is closed the arm of the lever mentioned, and a bar connected with it, are brought below the pivot line connecting the pivoted centers of this lever and bar, whereby a lock will be formed which prevents the gate from being opened.

Mr. William E. Harris, of New York city, is the patentee of an improved amalgamator for separating fine gold from pulverized ore or sands. An amalgamating pot is set in a case, which is made steam tight in the upper part of it. The quicksilver is deposited inside the pot, and steam at a pressure of about forty pounds is conducted in contact with the ore, as the latter is fed through a funnel-shaped conductor, a stream of water flowing with the ore through the same funnel, which ore is forced by the steam into the quicksilver, where the particles of gold are taken up, and the refuse is permitted to run to waste.

To provide a better means for producing and distributing heat into dwelling apartments and offices from stoves than has been heretofore employed, is the subject of a patent recently granted to Mr. Wm. H. Pratt, of Rondout, N. Y. The device substituted by Mr. Pratt for the ordinary drum and base burning stoves does not interfere with the primary use of the stove, and it is claimed that a great saving is effected in the combustion of coal by the use of his steam heating attachment, which may be applied at very little expense to most kinds of stoves other than the base burning kind.

A novel grain and seed cleaning mill has been patented by Mr. William Bowen, of Edina, Mo. The object of which is to separate the chaff and poor seeds from the good seeds. The inventor provides a cylinder with a series of inclined plates, upon which the grains or seeds are fed, which cylinder is vibrated, so as to cause the light grains and seeds to pass to one corner of the plates and through apertures, while the heavy grains and seeds pass over the front edge of the plates into a chamber surrounding the cylinder. The cylinder is geared to vibrate, and the plates are made of highly polished hard wood, glass, or other smooth material.

Mr. Robert C. Snowden, of Elizabeth, Pa., has obtained a patent on a metal bending machine for tin roofers, which is intended to save much hard work, time, and expense to tin roofers. A great deal of work has been heretofore done on the roof which this machine is intended to do in the shop. By this machine each sheet of tin is bent upward at a right angle on one edge, and on the other edge is bent up at a right angle and then down again to lap over the standing edge of the adjacent sheet or plate, thus rendering them ready to lay when taken upon the roof. The interlocked edges of the plates are hammered down, and form a water tight joint without the use of solder.

An invention for indicating to the engineer or conductor of a railway train, when approaching a station, the time the previous train passed is the subject of a patent recently granted to Mr. Orry M. Shepard, of Boston, Mass. Attached to the station house is a lantern, which is not only provided with dials for denoting the time the preceding train had passed, but has provision for exposing transparencies on which is indicated the nature of the train last passed—freight, express, local, etc. The station master exposes the appropriate sign to the incoming train from inside the station, so that the conductor may not only see the time the last train passed the station, but the nature of the train, if it were passenger, freight, etc.

An improvement in davits for boats, designed to economize space and promote convenience in the raising and lowering of boats, has been patented by Mr. John F. Mumm, of Brooklyn, N. Y. The davit arm, which is curved outwardly, is provided at its outer end with a tackle in the ordinary manner. The lower extremity of the davit arm is pivoted in the lower portion of the davit socket, which is formed of two parallel plates, the upper edges being curved in the arc of a circle, and provided with shoulders at their ends. The movement of the davit arm is limited by the said shoulders. By this construction of the davit, the boat is held either over the water or over the deck of the vessel by gravity.

Improvements in evaporating pans for saccharine juices have been made by Mr. Jacob Shoemaker, of La Crosse, Wis., for which he has received letters patent. The invention consists in forming the pan of a number of plates, which are joined together by turning up a flange on the edge of each plate and uniting these flanges by solder, so that the solder will not be subjected to the direct heat, whereby the pan is rendered much more durable. The furnace is located directly underneath the pan, and is provided with two flues and connecting valves for regulating the heat of the furnace. An inclined trough is mounted upon crank supporting rods directly over the pan, and is so arranged that it may be swung from over the pan out of the way when it is not required for use.

An improved shingle machine has been patented by Mr. John P. Bowling, of Guthrie, Ky., the object of which is to provide a planing device for a shingle machine, which may be conveniently geared with a riving device. The shingles are planed to a uniform bevel by transferring them from the riving device to the planing device while both devices are in operation. The same inventor has likewise obtained a patent, bearing the same date as the above, for riving bolts out of hard woods. By an ingenious arrangement of the apparatus the weight of the bolt causes the balanced frame on which it rests to dip to the thickness of the shingle below, insuring each shingle of the same

thickness. Gauges are provided, which are set to regulate the thickness of the shingle.

An improved machine for weighing and measuring grain as it is delivered from the thrashing machine or elevators is the subject of a patent recently granted to Mr. Freeman C. Mason, of Ransom, Mich. A weighted hopper or receptacle is suspended on pivots, which receptacle is divided by a board forming an upper and lower compartment. The grain is deposited in the first compartment, and when it is full is discharged into the second compartment by the tilting of the receptacle, which is operated automatically by the weight of the grain. The alternate movements of the box operate a pawl and ratchet, which conveys to a dial plate the number of times the receiver discharges its contents, and thus the amount of grain that passes through the machine is accurately denoted, and may be seen at a glance.

A novel musical instrument called a piano-violin is the subject of a patent recently issued to Messrs. J. Parsons and J. W. Trinkle, of Kent, Ind. A case is provided containing two sounding boxes, one resting behind and connected to the other. To the front side of the inner sounding box is secured a bridge transversely to the box. To the front of the bridge a series of jaws are secured, between which the string bars are passed, the latter of which are provided with a spring tongue. An endless belt is made to pass by the strings in the instrument by means of a treadle, and as the keys are depressed, the corresponding strips will be drawn upward, bringing the lower end of the corresponding string bar toward the belt, which coming in contact with the string produces a vibration and sound as long as the belt is kept in contact with the string.

## AGRICULTURAL INVENTIONS.

A useful garden implement in the form of a combined plow, planter, and cultivator has recently been patented by Mr. G. Glidden, of Buchanan, Mich. It is a hand machine, and accomplishes a number of objects, such as marking the ground, planting and covering the seed, and cultivating the plants, and is withal simple and cheap in construction.

A harrow provided with a seat and otherwise so arranged that the attendant, by means of a lever, can raise or lower the harrow without leaving his seat, has been patented by Mr. Thomas Van Ostrand, of Kinsley, Kan. Provision is made for changing the angle of the teeth, when desired, by means of another lever, and this may also be done without the driver leaving his seat. Taken altogether, this new riding harrow seems to transform the ordinary process of harrowing from tiresome labor into a pleasant pastime.

## MISCELLANEOUS INVENTIONS.

Mr. John H. Solis, of New York city, has patented an improved compression basin cock, constructed in such a manner that it can be closed by turning the valve stem through a quarter of a revolution in either direction. The invention seems to be a valuable improvement over the ordinary basin cock.

Mr. J. L. Clingman, of Cynthiana, Ky., has added to the list of railway supply appliances a new nut lock for rail joints. It is a very simple device, cheap to make, very strong, and at the same time it is capable of removal and reapplication without damage to any of its parts.

A patent for a gas seal for blast furnaces was granted a few weeks ago to Mr. E. A. Uehling, of Sharpsville, Pa. The newly patented gas seals are opened and closed automatically in the charging of furnaces by a system of levers, which are so fitted as to be operated by either steam or compressed air.

A steam radiator of novel construction has recently been patented by Mr. A. A. Griffing, of Jersey City, N. J., the object of which is to so construct a radiator tube and its interior air pipe that a maximum of heat will be applied to the air as it circulates through the interior pipes.

Mr. Peter Dickman, of Defiance, O., has patented an improved rub iron to fasten on the side of carriages to prevent the wheels from scraping the body when cramping or turning around. The iron being nearly the same form as the wheel on its wearing surface, there is no possibility of the wheels locking.

An improved furnace door latch which closes automatically, and holds the door perfectly closed against the action of the heat, has recently been patented by Mr. E. J. Shields, of Elizabethport, N. J. The simplicity of this invention is very great, and it can be applied to stoves as well as to large furnaces.

Mr. F. T. Knauss, of Scranton, Pa., has recently patented improvements on his knock-down table, which was originally patented May 2, 1882. The invention relates principally to certain details of construction of the frame, mode of attaching the legs to the table, etc.

A novel clothes pin has been patented by Mr. Richard B. Perkins, of Hornellsville, N. Y. The pin is of the usual clothes pin shape with slot, and the invention consists of a spring wire which is inserted in the pin, to prevent the clothes pin from dropping from the line, and also to prevent the garments from blowing away.

Mr. F. A. Curpen, of Upper Sandusky, O., has patented a hair spring protector for watches, which is intended to prevent the liability of the second curl of the spring being caught by the pins. To obviate the difficulty heretofore experienced, Mr. Curpen provides a device for closing the space between the pins after the spring is applied.

An improvement in sheet metal elbows for stove pipes, etc., has been patented by Mr. Alexander F. Peters, of Millbury, Mass. The inventor produces a very strong, smooth, and durable elbow for stove pipes by making it in longitudinal sections, which parts are closed by lap folded seams at the outer straight portions and by flange joints at the curved parts.

A patent for a very simple boiler cleaner has recently been issued to Mr. G. A. Chapman, of Strawberry Point, Iowa, which, it is claimed, will not only prevent the formation of scale, but by the action

of the heat and water will remove what has already formed, and carry off the particles of both the scale and sediment from the boiler through a discharge pipe.

Mr. O. C. Retsloff, of Winnebago City, Minn., has patented an improved pendulum, the object of which is to provide for the accurate regulation of pendulum clocks by adjustment of the length of the rod. A bob is fitted to the pendulum and rotated by an adjusting nut with a pointer attached, to indicate on a dial the extent of the movement.

An improvement in that class of ornamental chains in which a large number of units are joined together by pins to form a band of any desired width, and known to the trade as "roller chains," is the subject of a patent recently granted to Mr. N. P. Carter, of Brooklyn, N. Y. By countersinking the outside edges of the units, and using rivets that head within the rim, a strong and well finished chain is produced.

Messrs. William Oldroyd, of Columbus, and George H. Smith, Jr., of Lancaster, O., have patented an improvement in hair spring studs for watches. The object of this improvement is to effect the necessary lengthening or shortening of the hair spring, and putting the watch in perfect beat without detachment of parts or changing the collet at the center of the balance wheel.

A latch has been patented by Mr. L. A. Randall, of Birmingham, Mich. The bolt is so contrived as to automatically shift forward by gravitation into the position by which it engages with the catch. The bolt is made reversible in different ways, and by this arrangement, in connection with the locking device, by which the spring usually employed is dispensed with, renders the lock more secure and durable.

Mr. E. S. Kingston, of Little Falls, N. Y., has received letters patent for an improvement in shoe makers' lasts. This device is made of malleable iron in such a form that it can be removed from a boot or shoe in one piece instead of in sections. A spring keeps the upper section of the last in place, which contracts when pulled upon, allowing it to leave the shoe, requiring but slight effort on the part of the workman.

A canteen, water cooler, jug, or vessel, made of metal or other stiff material, and having a portion or the whole of its body provided with perforations and clothed with a covering of cloth or other absorbent material, is the subject of a patent recently granted to Mr. C. G. Jordon, of Catlin, Colo. Evaporation is promoted and the liquid contents of the vessel are kept cool by the above arrangement of materials, and its use in hot climates must prove a convenience and luxury.

Mr. Joseph C. Cramer, of Leadville, Colo., has patented a novel improvement upon a pick for which he obtained a patent November 8, 1881. This present invention consists in forming the outer wall of the eye in the socket head with an inwardly projecting enlargement, and in forming a depression in the back of the pick to fit it. Further, the socket head is provided with a pivoted plate for locking the wedge in place, the end of the plate being adapted to enter a slot in the wedge.

Mr. Olin Pitts, of Newborn, Ga., is the patentee of a back band hook for harness, the object of which is to prevent the destruction of the lines or ropes used as reins when plowing. A plate is hooked into the harness belt, which plate is provided with two prongs or projecting hooks, through one of which the reins run on a friction roller, and the other supports the trace chain. By this device the reins are prevented from getting entangled with the traces, and are kept from the ground when the team is slackened up.

Mr. G. W. Dossie, of Haring, Mich., recently secured letters patent for an improvement in logging wheels for carting heavy lumber. The tongue is used as a lever for raising the logs into place between the wheels. A guard against damage to the spokes from the swinging of the chains or logs in going over rough roads is provided, and a seat is attached for the driver. In the act of hoisting, the team is attached to the end of the tongue by a long chain, by which is actuated an eccentric hitch of the suspending chains on the axle.

A simple device for tightening the tires of vehicles is the subject of a patent granted to Messrs. Peter and James Young, of Monticello, Iowa. The invention consists in a novel mode of tightening the tires of wagon or other vehicle wheels, without removing the tires from the wheels. A strong metal band of the size the tire should be when tightened is heated quite hot, and while expanded by the heat it is clasped snugly over the wheel tire, which shortens it to the size desired by the contraction of the outer band, aided by the screw and nut, which are used to bring the tightening hoop band upon the tire.

A barrel adjuster is the title of a patent recently granted to Mr. William E. Foreman, of Pierrepont Manor, N. Y., the object of which is to enable a barrel to be rolled upon the frame while the latter is folded flat to the floor. The frame, or adjuster, as it is termed, is then raised into position by a lever, with the barrel upon it. The barrel is held firmly in any position desired for drawing off the contents. The frame is preferably of metal, neatly constructed, and the contrivance is admirably adapted for the dispensing of lager beer, and will be likely to come into extensive use by saloonkeepers.

Messrs. Robert B. F. Reed and George Freund, of Durango, Colo., have recently patented a safety shell for blasting purposes where high explosives are employed, such as giant powder. The material is used in sticks or candles, and for firing the charges a cap is attached to the end of the stick at the end of the fuse. The method of attaching the cap has heretofore been to bore a hole in the end of the candle and insert the cap, which is held in place by a winding of cloth. This method is both unreliable and dangerous, from the fact that as the candle has to be warmed before it can be bored the charge is liable to be exploded by the warming, and the cap to be disconnected, so that the firing of the charge is prevented or delayed so long as to result in an accident. The object of the present invention is to obviate these difficulties and to secure perfect safety in the use of giant powder and similar materials for blasting purposes.

**Business and Personal.**

*The Charge for Insertion under this head is One Dollar a line for each insertion; about eight words to a line. Advertisements must be received at publication office as early as Thursday morning to appear in next issue.*

**Guild & Garrison's Steam Pump Works, Brooklyn, N. Y.** Steam Pumping Machinery of every description. Send for catalogue.

Wanted.—Foreman for malleable iron foundry. One familiar with the running of air furnaces preferred. Address M. J. C., Letter Carrier No. 72, St. Louis, Mo.

For Sale Cheap.—Patent in the agricultural malleable hardware line. E. L. Bracken, Dawson, Ill.

Electrical Works.—Splendid chance to purchase the oldest telegraph supply depot in Ohio. Best facilities for manufacturing all kinds electrical instruments, burglar alarms, etc. Address M. A. Buell, 144 Superior Street, Cleveland, Ohio.

The New System of Bee Keeping.—Every one who has a farm or garden can keep bees on my plan with good profit. *Illustrated circular of full particulars free.* Address Mrs. Lizzie E. Cotton, West Gorham, Maine.

Things to be remembered: That the Esterbrook Steel Pens are of standard quality; are adapted to the needs of all writers; are reasonable in price; and are to be had of all Stationers.

Wanted.—Iron castings to make. Give us a chance to make a bid on your work. Lehigh Stove and Mfg. Co., Leighton, Pa.

Wanted.—A first-class Brass Pattern maker as foreman in our pattern room. Must be a draughtsman, sober, and industrious, and come well recommended. State age and salary expected; married man preferred. Address Duggan Parker Edw. Mfg. Co.'s Malleable Iron Works, 806 to 822 South 12th Street, St. Louis, Mo.

Fire Brick, Tile, and Clay Retorts, all shapes. Borgner & O'Brien, M'rs, 23d St., above Race, Phila., Pa.

Peck's Patent Drop Press. See adv., page 237.

Steam Hammers, Improved Hydraulic Jacks, and Tube Expanders. R. Dudgeon, 24 Columbia St., New York.

Diamond Saws. J. Dickinson, 64 Nassau St., N. Y.

50,000 Emerson's Hand Book of Saws. New Edition. Free. Address Emerson, Smith & Co., Beaver Falls, Pa.

Eagle Anvils, 10 cents per pound. Fully warranted.

For Pat. Safety Elevators, Hoisting Engines, Friction Clutch Pulleys, Cut-off Coupling, see Frisbie's ad. p. 237. Gould & Eberhardt's Machinists' Tools. See adv., p. 237.

For Heavy Punches, etc., see illustrated advertisement of Hilles & Jones, on page 238.

Barrel, Key, Hogshead, Stave Mach'y. See adv. p. 237.

For Mill Mach'y & Mill Furnishing, see illus. adv. p. 236. See New American File Co.'s Advertisement, p. 238.

Mineral Lands Prospected, Artesian Wells Bored, by Pa. Diamond Drill Co. Box 423, Pottsville, Pa. See p. 237.

Renshaw's Ratchet for Square and Taper Shank Drills. The Pratt & Whitney Co., Hartford, Conn.

For best low price Planer and Matchner, and latest improved Sash, Door, and Blind Machinery, Send for catalogue to Rowley & Hermance, Williamsport, Pa.

The Porter-Allen High Speed Steam Engine. South-work Foundry & Mach. Co., 430 Washington Ave., Phil. Pa.

Steam Pumps. See adv. Smith, Vaile & Co., p. 236.

Boiler Scale.—Parties having fine specimens for sale or loan, address Jas. F. Hotchkiss, 84 John Street, N. Y.

Farley's Directories of the Metal Workers, Hardware Trade, and Miners of the United States. Price \$3.00 each. Farley, Paul & Baker, 530 Market Street, Phila.

Woodwork'g Mach'y. Rollstone Mach. Co. Adv., p. 221.

Common Sense Dry Kiln. Adapted to drying of all material where kiln, etc., drying houses are used. See p. 222.

Lightning Screw Plates, Labor-saving Tools, p. 222.

The Best.—The Deuber Watch Case.

Curtis Pressure Regulator and Steam Trap. See p. 206.

The Sweetland Chuck. See illus. adv., p. 206.

Knives for Woodworking Machinery, Bookbinders, and Paper Mills. Taylor, Stiles & Co., Riegelsville, N. J.

The Celebrated Wooten Desk. See adv., page 206.

Comfort Dinner Pails.—Most convenient in use. For sale everywhere. Reardon, Ennis & Co., Troy, N. Y.

C. B. Rogers & Co., Norwich, Conn., Wood Working Machinery of every kind. See adv., page 190.

Permanent Exposition.—Inventors' Institute, Cooper Union, N. Y. City. Every facility for exhibition of machinery, merchandise, and inventions. The expense is small—the advantages great. Send for particulars.

Contracts taken to manuf. small goods in sheet or cast brass, steel, or iron. Estimates given on receipt of model. H. C. Goodrich, 66 to 72 Ogden Place, Chicago.

Nickel Plating.—Sole manufacturers cast nickel anodes, pure nickel salts, polishing compositions, etc. Complete outfit for plating, etc. Hanson & Van Winkle, Newark, N. J., and 92 and 94 Liberty St., New York.

Lists 29, 30 & 31, describing 4,000 new and 2d-hand Machines, ready for distribution. State just what machines wanted. Forsaith & Co., Manchester, N. H., & N. Y. city.

"Abbe" Boit Forging Machines and "Palmer" Power Hammers a specialty. Forsaith & Co., Manchester, N.H.

Magic lanterns, stereopticons, cond. lenses, etc., on hand and made to order. C. Beseler, 218 Centre St., N. Y.

Railway and Machine Shop Equipment. Send for Monthly Machinery List to the George Place Machinery Company, 121 Chambers and 103 Reade Streets, New York.

25' Lathes of the best design. G. A. Ohl & Co., East Newark, N. J.

For Power & Economy, Alcott's Turbine, Mt. Holly, N. J.

"How to Keep Boilers Clean." Book sent free by James F. Hotchkiss, 84 John St., New York.

Engines, 10 to 50 horse power, complete, with governor. \$250 to \$550. Satisfaction guaranteed. More than seven hundred in use. For circular address Heald & Morris (Drawer 127), Baldwinville, N. Y.

Wanted.—Patented articles or machinery to make and introduce. Gaynor & Fitzgerald, New Haven, Conn.

Latest Improved Diamond Drills. Send for circular to M. C. Bullock Mfg. Co., 80 to 88 Market St., Chicago, Ill.

Water purified for all purposes, from household supplies to those of largest cities, by the improved filters manufactured by the Newark Filtering Co., 177 Commerce St., Newark, N. J.

Wanted.—Parties to manufacture baby carriage wheels of iron and steel. Moore, 34 and 36 Elizabeth Street, New York.

Ice Making Machines and Machines for Cooling Breweries, etc. Pictet Artificial Ice Co. (Limited), 142 Greenwich Street. P. O. Box 3083, New York city.

Split Pulleys at low prices, and of same strength and appearance as Whole Pulleys. Yocom & Son's Shafting Works. Drinker St., Philadelphia, Pa.

Machinery for Light Manufacturing, on hand and built to order. E. E. Garvin & Co., 139 Center St., N. Y. Presses & Dies. Ferracute Mach. Co., Bridgeton, N. J.

Supplement Catalogue.—Persons in pursuit of information on any special engineering, mechanical, or scientific subject, can have catalogue of contents of the SCIENTIFIC AMERICAN SUPPLEMENT sent to them free. The SUPPLEMENT contains lengthy articles embracing the whole range of engineering, mechanics, and physical science. Address Munn & Co. Publishers, New York.

**NEW BOOKS AND PUBLICATIONS.**  
THE MAGAZINE OF ART. Cassell, Petter, Galpin & Co., New York. Monthly, \$3.50 a year.

As its title implies, the *Magazine of Art* is an illustrated publication pertaining to art and art culture. It is issued in monthly parts, and every number abounds in beautifully executed engravings of famous paintings, interior views of modern houses and ancient castles, and fine art objects of a varied kind. The March number contains among other illustrations of interest several views of the most important and artistic rooms in the new residence of Mr. William H. Vanderbilt, on Fifth Avenue, this city.

THE DECORATOR AND FURNISHER. E. W. Bollinger, 75 Fulton Street, New York. Monthly, \$4 a year.

Some examples of inside decorations for houses, including the arrangement of the rooms, painting of the walls, designs for the furniture, window and hanging curtains, fireplace mantels, wall papers, etc., are illustrated and described in this magazine. The publication treats on all departments of house decoration and furnishing, and is therefore useful to those persons who are building new houses or altering over old ones. The magazine contains valuable suggestions to housewives on embellishing their homes, and rendering them attractive at small cost. The engravings are finely executed, and the descriptive letter press is printed on the page opposite the illustration, or in close proximity to it, so that the eye rests upon the latter while the description is read. Some of the examples of parlor and hall decorations are printed in several colors, which enables a person to see the effect of the different colors as arranged, and teaches them how to form harmonious combinations with other colors. The magazine is useful to architects, house furnishers, and decorators, and entertaining for all classes of readers.

HYDRAULIC MANUAL, CONSISTING OF WORKING TABLES AND EXPLANATORY TEXT, INTENDED AS A GUIDE IN HYDRAULIC CALCULATIONS AND FIELD OPERATIONS. By Lewis D'A. Jackson. 8vo, pp. 179. London: Crosby Lockwood & Co.

In the present edition of this standard work, some alterations and extensive additions have been made, although the same general principles have been adhered to that were enunciated in the first edition of 1868; the same limited object has been kept in view; and the same opposition to old hydraulic text books and old formulas is still maintained. The working tables in this edition have been increased from a hundred to a hundred and eighty pages, and enlarged in other respects. They have also undergone some rearrangement, though not sufficient to confuse those accustomed to the use of the tables in their previous form. This work will prove invaluable, as a work of reference, and as a guide in calculations and field operations, to every civil engineer.

MCCARTY'S ANNUAL STATISTICIAN. 8vo, pp. 624. 1883. San Francisco and New York.

This work, now in its sixth edition, is a perfect encyclopedia of statistical information, in condensed form, on almost every topic relating to human progress and events, and pertaining to biography, history, all branches of science, finance, etc. As the author very justly observes, the possession of a copy of this book "will save any pupil, teacher, superintendent, or school officer time, and give him more satisfaction than any similar number of pages in the English language."

BULLETIN OF THE UNITED STATES FISH COMMISSION. Vol. I. 1881. Washington: Government Printing Office.

This is the first of a series of volumes that Congress has authorized to be printed for the purpose of promptly disseminating the large amount of information that is constantly being acquired by the Fish Commission, through correspondence. The present volume contains many announcements that are of considerable importance in relation to the subjects of fish culture and capture.

HANDRAILING AND STAIRCASING. By Frank O. Creswell. 16mo, pp. 95. London and New York: Cassell, Petter & Galpin.

In this little work, which has been prepared to encourage working joiners to study drawing, practical details of stairs are given and explained, and a system of handrailing is introduced which is claimed to be simple and accurate. The book will doubtless serve to remove difficulties from the paths of numerous beginners, and induce many others to study this branch of the joiner's trade.

CHRONOLOGICAL HISTORY OF THE ORIGIN AND DEVELOPMENT OF STEAM NAVIGATION. By George Henry Preble. 8vo, pp. 483. Philadelphia: L. R. Hamersly, 1883.

This interesting volume is a revision and chronological arrangement of a number of "Notes for a History of Steam Navigation" that the author has been collecting for the last twenty-five years, and most of which have been printed in the *United Service Magazine* during the last eighteen months. The work does not fol-

low all the inventions and improvements in ships and navigation that have intervened, but begins with the first practical use of steam as a motive power for vessels at the beginning of the present century, and shows the progressive advance in steam navigation up to our own day. It will be gratifying to American readers of this book to find how large a share their countrymen have had in the invention of the steamboat.

PRACTICAL MECHANICS. By John Perry, M.E. With numerous illustrations. Cassell, Petter, Galpin & Co., London, Paris and New York, 1883. Pp. 271. Price \$1.50.

This little book is one of the series of "Manuals of Technology," which is edited by Professor Ayrton, F.R.S., and R. Wormell, D.Sc., and is an attempt to place before non-mathematical readers a *method* of studying mechanics. It will doubtless prove a most valuable aid to the intelligent mechanic or foreman who has not enjoyed the advantages of a liberal education, but who desires to add to his own practical knowledge an insight into the laws that govern matter. The readers of this book are supposed to have some previous knowledge of the behavior of materials and machinery, and the treatment which the subject receives differs from that generally met with in school text books, inasmuch as the author attempts to approach it from the practical side, believing that the most illiterate men may be rapidly taught practical mechanics in this way, for, unlike school boys or college students, the pupils may already possess an excellent foundation on which a superstructure of knowledge may be built. When glancing over the work, the non-mathematical student will probably be frightened by the free use of mathematical formulas, and feel inclined to doubt the assertion made in the preface that it is intended for *non-mathematical* readers. However, on reading the book carefully it will be found that each point is fully elucidated as it arises, and though a few hints from a teacher might be an advantage at the start, the persevering student will generally succeed in conquering the difficulties alone. The book contains a large number of experiments, which should be repeated by the student with sufficient care to obtain satisfactory quantitative results.

TECHNICAL DICTIONARY—SPANISH AND ENGLISH.

The growing commerce with our southern neighbors, Cuba, Mexico, Central and South American States, in which the beautiful Spanish language is still preserved, and the remarkable industrial progress now going on in Spain, render especially needful a good book of technological definitions in the Spanish and English languages. Mr. N. Ponce de Leon, the well known editor of this city, 42 Broadway, has undertaken to supply this want, and we have now before us the first part, entitled as above. The work is to be completed in two volumes, each issued in twelve parts of about 48 pages, at 50 cents per part. The first volume will consist of English technological terms with Spanish definitions. The second volume will present Spanish technology with definitions in English. The volumes will give the terms and phrases used in applied sciences, industrial arts, fine arts, mechanics, mines, metallurgy, agriculture, commerce, navigation, manufactures, architecture, civil and military engineering, marine engineering, military affairs, railway engineering, electricity, telegraphy, etc.

REPORT OF THE NEW YORK STATE SURVEY FOR THE YEAR 1881. James T. Gardner, Director. Albany, 1882. Assembly Document, No. 94. Pp 94. Maps v.

The report before us shows that a considerable amount of work was done during the year in the matter of triangulation. Twenty-nine signals were erected, three of which were towers 30 feet high, one 40 feet, and another 50 feet. The body of the report consists of tables showing the latitude, longitude, azimuth, etc., of each station and of many prominent objects, such, for instance, as the Catskill Mountain House, High Peak, Overlook Mountain, Union College dome and other points in Schenectady, the old Capitol and other points in Albany, as well as Hudson City. Five large trigonometrical maps accompany the report.

**Notes & Queries**

HINTS TO CORRESPONDENTS.

No attention will be paid to communications unless accompanied with the full name and address of the writer.

Names and addresses of correspondents will not be given to inquirers.

We renew our request that correspondents, in referring to former answers or articles, will be kind enough to name the date of the paper and the page, or the number of the question.

Correspondents whose inquiries do not appear after a reasonable time should repeat them. If not then published, they may conclude that, for good reasons, the Editor declines them.

Persons desiring special information which is purely of a personal character, and not of general interest, should remit from \$1 to \$5, according to the subject, as we cannot be expected to spend time and labor to obtain such information without remuneration.

Any numbers of the SCIENTIFIC AMERICAN SUPPLEMENT referred to in these columns may be had at this office. Price 10 cents each.

Correspondents sending samples of minerals, etc., for examination, should be careful to distinctly mark or label their specimens so as to avoid error in their identification.

(1) P. J.—An ink for type writer ribbons is made as follows:

- Aniline black..... ½ oz.
  - Pure alcohol..... 15 "
  - Concentrated glycerine..... 15 "
- Dissolve the aniline black in the alcohol and add the glycerine.

(2) L. M. L. says: I have quite a collection of chrysalides, and should like to have your opinion in regard to some good work to assist me in classifying them and the butterflies, when they come out. A. Of general works on North American insects and their transformations we recommend Th. Harris' "Treatise on Insects Injurious to Vegetation," and A. S. Packard's "Guide to the Study of Insects." Of works on the classification and systemization of Lepidoptera we have only the incomplete and now antiquated synopsis of the North American Lepidoptera by J. G. Morris, published many years ago by the Smithsonian Institution and long since out of print. Numerous monographs of single families and genera have, however, been recently published by various authors, but the literature is scattered through the transactions and proceedings of our scientific societies and the publications of the government. We would also recommend C. V. Riley's Reports on the Insects of Missouri.

(3) H. B. C. writes: We have tried to copy some articles, like bright tacks, and followed a recipe which says: "Cleanse the articles perfectly and dip in a solution of 3 pounds rain water and 1 pound sulphate of copper." The copper coats the surfaces nicely enough, but when apparently solid, will peel off like bark, leaving a dirty black surface underneath. And how should one dry articles so coated so as to leave them nice and bright? A. We recommend the use of solution of copper nitrate instead of the sulphate. Dissolve one-half ounce of pure copper in nitric acid, and use the battery. Everything in use must be perfectly clean.

(4) W. W. A. asks: 1. What is the best and cheapest to mix with hard coal dust for fuel? A. The general method of employing coal dust is to compress it into bricks, but this requires machinery. We would recommend that the coal dust be mixed with as little clay as possible, and water, and then made into a paste and dried. 2. Is there anything to put in the inside of stove pipe to keep it from eating through? A. Asphaltum..... 2 lb.  
Boiled linseed oil..... 1 pint.  
Oil of turpentine..... 2 qts.

Fuse the asphaltum in an iron pot, boil the linseed oil, and add while hot. Stir well and remove from the fire. When partially cooled, add the oil of turpentine.

(5) E. D. T.—To produce a red color on billiard balls, first imbue the balls with a tin mordant, then plunge them into a bath of Brazil wood, or cochineal, or a mixture of the two. Lac dye may be used with still greater advantage to produce a scarlet tint. If the scarlet balls be plunged for a little while in a solution of potash, they will become cherry red.

(6) W. R. P.—The lengths of several large steamers are given below:

- City of Rome..... 586 feet.
  - Servia..... 533 feet.
  - Cephalonia..... 440 feet.
  - Pavonia..... 430 feet.
  - Gallia..... 450 feet.
  - Austral..... 474 feet.
  - Orient..... 464 feet.
  - City of Berlin..... 489 feet.
  - City of Richmond..... 450 feet.
  - City of Chester..... 444 feet.
- There are many others over 400 feet in length.

(7) S. H. J.—The sulphocyanide of mercury is made by mixing solutions of mercurous nitrate with potassium sulphocyanide. It forms a white precipitate. The solutions are best made quite dilute before mixing. Use city pressure to feed your boiler, it is best to have a pump in case of emergencies.

(8) C. D. A.—For black ink try extract of logwood, 4 ounces; potassium dichromate, 12 grains; potassium ferrocyanide, 12 grains; distilled water, 1 gallon.

(9) J. H. N. wishes to know (1) what is fluate of lime. A. Fluorspar is its common name. It is a mineral. 2. How prepared? A. It is found in nature, and ground. 3. Will not sulphuric acid direct from the manufactory, mixed with the fluate of lime, answer the purpose of glass etching? If not, how could I concentrate it myself? A. It will. 4. What is white acid used by embossers; is it fluoric acid? A. White acid is fluoric acid. 5. What numbers of the SCIENTIFIC AMERICAN SUPPLEMENT afford the information on etching on glass and also glass painting, and also are such numbers in print, so that I can get them? A. SUPPLEMENT No. 313. Any back numbers of the SUPPLEMENT can be had at this office.

(10) L. D. D. writes: In a number of the SCIENTIFIC AMERICAN, dated January 20, 1883, was an article headed "Sulphurous Acid in Consumption." Can you tell me how it can be produced cheaply and conveniently, so that consumptives can produce it in their own homes? Am I to understand by the article that it can be produced by evaporation on a hot stove? A. Sulphurous acid is prepared by burning sulphur in the air. We would recommend that it be taken only under a physician's direction.

(11) J. C. asks: 1. Can you use in constructing an induction coil wire of the sizes 19 and 29 respectively, instead of those prescribed in your SUPPLEMENT No. 160? A. Yes, but you would get better effects by using a finer secondary wire and a coarser primary. 2. Instead of the naked wire for secondary coil, can I use S. C. wire? A. Yes. 3. May I twist the ends of the two parts of secondary coil instead of soldering; and if they must be soldered, what kind of solder is to be used? A. The ends may be twisted together; it would be better to solder them also. Common soft solder is used for this purpose.

(12) G. W. B. asks: 1. What size wire should the carbon disks be wound with in the Lyons transmitting telephone shown in SUPPLEMENT No. 163, page 2592? A. About No. 24. 2. Should it be silk covered or bare? A. Bare. 3. Would it improve the new form of transmitting telephone, SUPPLEMENT No. 163, page 2593, Fig. 4, to use a piece of platinum wire on the end of wooden spring instead of carbon? A. No. 4. Would it be an improvement to use a small induction coil, the same as with Lyons? A. Yes.

(13) G. R. R.—The theoretical velocity of air flowing into a vacuum is 1,347 feet per second.

(14) D. F. Co.—The term case hardening is generally applied to the operation of forming a superficial steel surface upon iron.

(15) J. W. W.—The "squeaking" or jarring noise in a music box is generally due to the absence of the small pieces of quill placed underneath the tongues to arrest them on the near approach of a pin.

(16) F. L. M. asks: 1. How many cells of battery will it take to work a telegraph line an eighth of a mile long, using a ground wire and having two instruments, one at each end of the line?

(17) J. K.—About 166 feet of gas can be made from a gallon of gasoline. Benzine will not answer. Better use some well tried gasoline machine.

(18) H. R. H.—The link motion is a very safe and sure arrangement for quickly reversing engines, and is therefore used on locomotives, hoisting engines, etc.

(19) F. W. I.—To deodorize petroleum, mix chloride of lime with petroleum in the proportion of three ounces for each gallon of the liquid to be purified.

(20) G. M. C.—Plumbago or powdered graphite mixed with some oily material is largely used for lubricating purposes. It is difficult to specify the exact proportions of each, but we would suggest experimenting until a suitable mixture was obtained.

- Beeswax..... 18 parts.
Spermaceti..... 6 parts.
Oil turpentine..... .66 parts.
Asphalt varnish..... 5 parts.
Borax, powdered..... 1 part.
Vine twig, black..... 5 parts.
Prussian blue..... 2 parts.

Melt the wax, add powdered borax and stir till a kind of jelly has formed. In another pan melt spermaceti, add the asphalt varnish, previously mixed with oil of turpentine, stir well, and add to the wax.

MINERALS, ETC.—Specimens have been received from the following correspondents, and examined, with the results stated:

W. A. C.—From a superficial examination of the specimen sent, it seems to be nothing more than common clay. An analysis would determine its value, if it has any.—A. B. C.—The sample is rock containing pyrite, iron sulphide, and is of no value.—R. B. I.—The mineral sent is a gold and silver ore; it contains pyrite carrying gold; galena carrying silver, with a slight coating of malachite (copper carbonate). It is worth an assay, which would cost about \$5.00.—J. W. B.—The sample is kalcinite, of value for porcelain manufactures.

[OFFICIAL.]

INDEX OF INVENTIONS

FOR WHICH

Letters Patent of the United States were Granted in the Week Ending

April 3, 1883,

AND EACH BEARING THAT DATE.

[Those marked (r) are reissued patents.]

A printed copy of the specification and drawing of any patent in the annexed list, also of any patent issued since 1866, will be furnished from this office for 25 cents. In ordering please state the number and date of the patent desired and remit to Munn & Co., 261 Broadway, corner of Warren Street, New York city. We also furnish copies of patents granted prior to 1866; but at increased cost, as the specifications, not being printed, must be copied by hand.

Acids and chemicals, apparatus for boiling, J. Hesch..... 275,041
Aerated water apparatus, A. D., Jr., & L. W. Puffer..... 275,076

Alphabet block and case, W. E. Crandall..... 275,329
Anthrachinone and alizarine, purifying impure. J. Brünner..... 275,128
Axes, machine for making, E. Rogers..... 275,273
Axle, car, M. O. Baldwin..... 275,323
Axle, car, G. W. Bedbury..... 275,324
Bag holder, C. T. Smith..... 275,086
Baling press, E. J. Bennett..... 275,118
Banjo, E. J. Cubley..... 274,915
Bar. See Furnace grate bar. Glazing bar.
Barrel making machine, J. S. O'Sullivan..... 275,072
Bathing apparatus and commode, combined, Q. S. Backus..... 275,011
Bed bottom, spring C. H. Fitch..... 274,925
Bedstead, G. Gentle..... 275,187
Bedsteads, etc., slat-support for, J. W. Hamerschmidt..... 275,202
Beehive, A. F. Combs..... 275,322
Block. See Toy block.
Board. See Vehicle dash board.
Boat plug, G. W. Renton..... 275,370
Boiler covering, H. C. Goodell..... 274,933
Boiler safety attachment, D. Sullivan..... 275,091
Bolt cutter, A. Blowers..... 275,015
Boot and shoe indicator, Woodlief & Dunn..... 275,108
Boot and shoe nail, H. R. Adams..... 275,101
Boot or shoe, L. E. Moore..... 275,248
Boring, drilling, and facing machine, W. E. Wild..... 275,103
Bottle, feeding, J. Thomas..... 275,288
Bottle or jar stopper or cover, A. V. Whiteman..... 275,101
Bottle wrapper, C. G. Biedinger..... 275,013
Box. See Toilet set box.
Braiding machine, J. McCahey..... 275,061
Bronzing machine, J. Humphrey..... 275,214
Brush and blacking box holder, combined blacking, E. L. Wood..... 275,107
Brush for bronzing, etc., J. F. Sargent..... 274,978
Buckle, R. G. Hanford, Jr..... 275,204
Burial case mould, C. E. Wilson..... 275,004
Burial casket, W. Hamilton..... 275,201
Burial casket, Powers & Walker..... 275,265
Burner. See Gas burner.
Butter case, Leete & Wilbur..... 275,235
Button, C. H. Kapp..... 275,218
Camera. See Photographic camera.
Can. See Glass lined metal can. Tilting can.
Candlestick, miners', J. C. Martin..... 275,087
Cane and pipe case, combined, J. P. Weaver..... 275,100
Capsule machine, H. H. Taylor..... 275,092
Car brake shoe, H. A. Banning..... 274,896
Car coupling, A. H. Armstrong..... 274,898
Car coupling, N. Campbell..... 275,138
Car coupling, B. W. Cloak..... 274,908
Car coupling, D. W. Coburn..... 275,150
Car coupling, E. C. Eyl..... 275,177
Car coupling, C. E. Mark..... 275,054
Car coupling, W. W. Newcomb..... 274,960
Car coupling, B. F. Whitney..... 275,306
Car, hand, G. S. Sheffield (r)..... 10,303
Car starter, Hewett & Leonard..... 275,211
Car, stock, E. Koehler..... 275,221
Car, stock, S. P. Tallman..... 274,991
Car window ventilator, railway, H. H. Reynolds..... 275,271
Cars, curtain bracket for sleeping, Doerr & Wigmore..... 275,164
Carbon rod or stick and mechanism for making the same, C. F. Brush..... 274,904
Carbureting apparatus, gas, N. A. Ransom..... 275,268
Carriage curtain fastener, G. L. Crandal (r)..... 10,301
Carrier. See Hay carrier.
Case. See Butter case. Show case. Watch case.
Caster, W. W. Box..... 275,126
Caster, combined salt and pepper, Lonergan & Farrell..... 275,231
Caster, furniture, O. Pederson (r)..... 10,304, 10,305
Castings, pattern for producing, J. E. Donovan..... 275,166
Ceiling, fireproof, A. W. Cordes..... 275,151
Celluloid, etc., apparatus for moulding, I. S. Hyatt..... 275,216
Celluloid, etc., manufacturing sheets of, I. S. Hyatt..... 275,215
Chains, machine for making ornamental, R. S. Matteson..... 274,955
Chair. See Folding chair. School chair.
Chair, C. P. Nash..... 275,252
Checking the arrival of employes, apparatus for, W. M. Llewellyn..... 275,229
Churn, Massie & Legan..... 275,059
Cigar cutter, P. Abbott..... 275,009
Clamp. See Floor clamp. Ironing board clamp.
Cleaner. See Cotton cleaner. Grain cleaner.
Cleaning compound, M. J. Gible..... 275,189
Clevis, plow, F. Bastam..... 274,897
Cloth pressing machines, bed for, G. W. Miller..... 275,243
Clothes wringer, J. E. Donovan..... 275,165
Clutch, friction, Gass & Galashan..... 275,186
Clutch hook, C. Green..... 274,935
Cock and low water detector, gauge, G. L. Engelking..... 275,175
Cock, gauge, D. F. Tousey..... 274,994
Collar, horse, J. W. Pearson..... 274,966
Compound for lining and coating tubes, cylinders, etc., also for joint packing, taking impressions, making castings, etc., indestructible, I. R. Blumenberg..... 275,123
Conveyer for mill products, R. Craik..... 275,153
Cooking apparatus, steam, J. E. Welling..... 275,302
Cooler. See Milk cooler.
Coop, poultry, F. M. Woolard..... 275,314
Corn sheller, G. H. Pattison..... 275,259
Cotton cleaner, C. W. Turner..... 275,095
Cotton gin feeder, M. L. Nix..... 274,961
Coupling. See Car coupling. Pump rod coupling.
Coupon shears, G. S. Van Pelt..... 274,998
Crib, child's, I. R. Opdyke..... 275,070
Crib, trundle, C. T. Shepard..... 274,982
Crucible furnace, gas, L. Stülwell..... 275,284
Crusher. See Ore crusher.
Cultivator, E. P. Davis..... 275,159
Cultivator, S. & R. Day..... 274,920
Cultivator, J. H. Nutting..... 274,962
Cultivator, W. H. Pennock..... 275,260
Cultivator and chopper, cotton, E. McCarty..... 275,062
Cultivator hoe, spring, A. B. Clark..... 275,146
Cupel furnace, J. Lynch..... 275,232
Injector cord tightener, F. J. Werneth..... 275,303
Curtain guide, E. F. De Witt..... 275,163
Curtain pin, J. Day..... 275,160
Cuspidor, sheet metal, G. T. Sutterley..... 275,285
Cut-off valve gear, J. M. Higbe..... 275,337
Cutter. See Bolt cutter. Cigar cutter. Vegetable cutter.
Cylinders, machine for reboring, W. E. Wild..... 275,102
Dart, H. L. Marbach..... 275,236
Dish, covered, T. Spencer..... 275,281
Dish made from ceramic material or glass, oval or circular, O. A. Gager..... 275,083
Door lock, sliding, W. T. Mingus..... 275,066
Dough cutting machine, L. J. Anger..... 274,892
Draught equalizer, W. H. Baker..... 275,321
Drawer pull, E. J. Blackham..... 275,326
Drawer pull, C. Rebstock..... 275,078

Drill. See Twist drill.
Drum, E. Boulanger..... 274,900
Drying kiln for bricks, etc., C. Chambers, Jr..... 274,907
Drying kiln for bricks, etc., H. Cockell..... 274,910
Dust pan, C. B. Banning..... 275,012
Dyes, apparatus for extracting, G. L. Allen..... 274,891
Electric elevator, S. D. Field..... 275,179
Electric light circuits, safety self-closing, shunt switch for, E. Thomson..... 275,289, 275,290
Electric machines, armature for dynamo, E. A. Edwards..... 275,169
Electric signaling apparatus, automatic, F. B. Wood..... 275,006
Electric wires, underground conduit for, H. Clay..... 275,023
Elevator. See Electric elevator.
Elevator, W. Goddard..... 275,037
Elevator, G. N. Reiff..... 275,080
Elevator, C. Whittier..... 275,003
Engine. See Traction engine. Transportable engine. Wind engine.
Engines, utilizing the exhaust of, D. Renshaw..... 274,969 to 274,973
Fabric. See Flocked fabric.
Fan attachment, P. Hebner..... 275,208
Fan exhaust, W. D. Smith..... 275,087
Fastening for straps, etc., R. G. Hanford, Jr..... 275,203
Faucet attachment, Ungemach & Oshe..... 274,996
Faucet, self-closing, T. H. Walker..... 275,099
Faucet, self-closing, R. L. Webb..... 275,300
Feather crushing machine, W. Hammermill..... 274,936
Feed water heater and feeder, J. Park..... 275,342
Felt upper for shoes or slippers, N. Moulton..... 275,250
Felt uppers for shoes or slippers, making, N. Moulton..... 275,249
Fence, hedge, W. Young..... 275,317
Fence, plashed, W. Baldwin..... 274,895
Fence post, F. Brown..... 275,131
Fence post, G. Swingle, 4th..... 275,286
Fencestay or brace, W. W. Worcester..... 275,007
Fertilizers, apparatus for desiccating animal matter for, H. Breer..... 274,902
Fertilizers, apparatus for treating animal matter for, H. Breer..... 274,901
Fire arrester and fire escape, combined portable, S. Richards..... 274,977
Fire escape, D. F. Black..... 275,121
Fire escape, W. W. Griffin..... 275,197
Fire escape, H. J. H. Schuett..... 275,083
Fire escape ladder, W. C. Bush..... 275,135
Fire shield, S. Richards..... 274,976
Flocked fabric or imitation textile fabric, C. A. Evans..... 275,176
Floor, basement or cellar, O. A. Smith..... 274,985
Floor clamp, H. F. & A. W. Case..... 275,017
Floors, partitions, etc., application of wire gauze in the construction of, J. McCarroll..... 275,240
Folding chair, H. J. Harwood..... 275,206
Food, process of and apparatus for curing articles of, A. J. Chase..... 275,145
Fork guard, T. F. Curley..... 275,155
Form, adjustable dress, S. M. Moschowitz..... 274,958
Frame. See Net frame.
Fruit, etc., apparatus for bleaching, J. R. Hillman..... 275,044
Fruit jar cover, H. A. Hoppe..... 275,047
Fur clipping and unhairing machine, T. Rasmus..... 275,077
Furnace. See Crucible furnace. Cupel furnace. Gas retort furnace. Puddling furnace. Roasting and reducing furnace.
Furnace grate bar, P. W. Lamb..... 274,949
Furnaces, machine for pushing tubes into, E. W. Wolfe..... 275,312
Galvanic battery pole, Blackall & Decker..... 274,899
Game, E. G. Williams..... 275,308
Gas burner, J. A. Wilson..... 275,311
Gas machine, H. S. Maxim..... 275,060
Gas retort furnace, R. Schliter..... 275,276
Gas retorts, device for fastening for mouth-pieces to, J. Dell..... 275,162
Gate, W. C. Pettis..... 275,262
Gelatine coated sheets, apparatus for stretching, O. Lelm..... 275,226
Generator. See Hydrocarbon generator. Hydrocarbon vapor generator.
Glass lined metal can, A. M. Graves..... 274,934
Glassware, device for handling, D. A. Brown..... 275,130
Glassware, manufacture of, W. M. Wallace..... 275,298
Glazing bar, C. H. Pennycook..... 275,261
Grain binder, J. F. Appleby..... 275,114
Grain binder, A. S. Clow..... 274,909
Grain cleaner, separator, and grader, W. E. Wild..... 275,104, 275,105
Guard. See Railway cattle guard.
Gun, magazine, Simmons & Adams..... 275,085
Gun rod, jointed, L. Keller..... 275,050
Hame attachment, G. J. Letchworth..... 275,228
Hammer and box scraper, F. A. Cowles..... 275,025
Harrow, sulky, J. Peess..... 275,090
Harvester, cotton, G. N. Todd..... 275,094
Harvester, grain binding, J. S. Davis..... 275,330
Hay carrier, J. Nettleton..... 275,254
Hay rack, N. P. Marsh..... 275,239
Hay rope, machine for twisting, J. W. Purslow..... 275,267
Heater. See Feed water heater.
Hemp drawing and spinning machines, feed regulator for, J. R. Hoover..... 275,046
Hides, etc., apparatus for scouring and fleshing, A. Whiting..... 275,305
Hog nose ringer, F. McConnell..... 275,241
Holder. See Bag holder. Lead or crayon holder.
Hook. See Clutch hook. Neck wear hook. Snap hook. Whiffletree hook.
Horseshoe, E. A. Carroll..... 275,141
Horseshoe blank roll, J. N. Clarke..... 275,022
Hose coupling, J. H. Luther..... 274,951
Hotel indicator, R. S. Hering..... 275,210
Hydrocarbon generator, H. F. Hayden..... 275,207
Hydrocarbon vapor generator and burner, Blumenberg & Whiting..... 275,124
Hygroscope, W. Klinkerfues..... 275,220
Ice cream freezer, D. S. Coskrey..... 275,152
Ice, process of and apparatus for blocking, G. W. Goodell..... 275,192
Indicator. See Boot and shoe indicator. Speed indicator. Station indicator.
Injector, D. Renshaw..... 274,968
Injector, feed water, W. McElroy..... 275,063
Inlaid frames, making, Baughart & Treat..... 274,898
Inlaying and embossing celluloid, W. F. Weber..... 275,343
Ironing board clamp, Ross & Bliss..... 275,275
Ironing machine, M. I. Remy..... 275,081
Jetty for connecting the channels of rivers, etc., T. E. Buck..... 275,132
Joint. See Pipe joint.
Journal bearing, C. E. Tibbles..... 275,292
Key. See Watch key.
Key seat milling machine, A. H. Campbell..... 274,906
Knitting machine, J. P. Kidder..... 274,947
Knitting machine burr, S. G. Hall..... 275,198, 275,199
Knob spindle fastening, C. L. Taylor..... 275,287
Lamp, D. D. Lockwood..... 275,230
Lamp, candlestick, etc., W. S. Tisdale..... 275,298
Lamp, electric arc, J. A. Dalzell..... 274,916

Lamp, electric arc, E. A. Edwards..... 275,168, 275,170 to 275,174
Lamp, electric arc, J. R. Finney..... 275,182, 275,183
Lamp, electric arc, F. G. Van Choate..... 274,990
Lamp, electric arc, S. F. Waterhouse..... 274,999
Lamp globe, electric, G. J. Murdock..... 274,959
Lamp, hydrogen, M. J. Hinden..... 275,046
Lamp, street, C. C. Kiefer..... 275,219
Lamps, manufacture of peg, J. Dalzell..... 274,917
Latch for sliding doors, E. M. Clough..... 275,149
Latch, gate, Saunders & Funkhouser..... 275,082
Lathe, turning, E. H. Leland..... 275,051
Lathes, counting attachment for gauge, J. D. Lammel..... 274,950
Lead or crayon holder, C. W. Boman..... 275,125
Liquids, apparatus for drawing, G. D. Burton..... 275,134
Lock. See Nut lock. Seal lock. Stencil plate lock.
Loom, G. Crompton..... 274,913
Magneto electric machine, S. Marcus..... 275,237
Malt, etc., apparatus for drying and roasting, L. Mautner..... 275,097
Mash for fermentation, apparatus for preparing, H. F. Moore..... 275,247
Match, R. Platz..... 275,074
Mattress, folding spring, P. J. Olander..... 274,968
Meat, preserving, M. Closset..... 275,148
Mechanical movement, G. Crompton..... 274,914
Mechanical movement, H. Wyman..... 275,109
Mechanical movement, reciprocating, J. C. Chapman..... 275,144
Metal working plant, A. Cooper..... 274,911
Milk cooler, D. B. Wooster..... 275,315
Milk for the manufacture of butter and cheese, apparatus for the treatment of, E. R. Powell..... 275,264
Milk for the manufacture of butter and cheese, treatment of, E. R. Powell..... 275,263
Mill. See Roller mill. Windmill.
Millstones, gauge for dressing and truing, H. D. Coleman..... 275,024
Mitten, W. Carter..... 275,142
Mould. See Burial case mould.
Mole trap, J. G. Souers..... 275,280
Mop head, A. Titus..... 275,294
Moth trap and tree protector, coddling, G. W. Thissell..... 275,093
Mower, lawn, J. W. Hobson..... 275,338
Mowing and reaping machine sickle eye, L. Hoffmann..... 274,942
Mowing machine, R. A. Leonard..... 275,227
Neck wear hook, W. W. Fichtenberg..... 274,924
Needle threading device, J. Darling..... 275,157
Nest egg, medicated artificial, C. B. Wainwright..... 275,237
Nest, hen's, J. Q. Sook..... 275,088
Net frame, horse fly, W. H. Osmer..... 275,071
Nut lock, F. Getz..... 275,188
Nut lock, T. Weaver..... 275,001
Nuts, bleaching edible, F. M. Ironmonger..... 275,217
Oil cake former and spring mat, W. F. Shaffer..... 275,278
Ore crusher and pulverizer, R. McCully..... 274,956
Packing, automatic metallic, H. P. Wenle..... 275,299
Packing for ice machines, W. A. Reid..... 275,269
Packing for valve stems, etc., L. Grannan..... 275,198
Pad. See Truss pad.
Paddle, feathering, G. A. Keene..... 274,945
Paddlewheel, C. P. Thresher..... 275,291
Pan. See Dust pan.
Paper folding machine, L. C. Crowell (r)..... 10,300
Paper, etc., machinery for folding, W. C. Cross..... 275,154
Paper making machinery, G. E. Marshall..... 275,056
Paste, adhesive, Schanze & Weigman..... 274,979
Photographic camera, folding, G. F. E. Pearsall..... 275,073
Picture mounts and frames, manufacturing, C. A. Wright..... 275,316
Pin. See Curtain pin.
Pin for neckwear shields, J. T. Lynch..... 275,234
Pipe bending machine, J. M. Evarts..... 275,029
Pipe joint, flexible, M. Walker..... 275,098
Pipe wrench, H. B. Williams..... 275,106
Planing machine, metal, F. B. Miles..... 275,242
Planter, corn, A. Fox..... 274,928
Planter, corn, J. Selby..... 274,981
Plow, R. W. Whitehurst..... 275,304
Plow, sulky, W. Strait..... 275,090
Post. See Fence post.
Post driver, R. M. St. John..... 274,989
Postal cabinet, L. C. Gray..... 275,194
Pot. See Tea pot.
Precious metals, apparatus for sizing and amalgamating, C. D. Bigelow..... 275,325
Press. See Baling press.
Printing blocks, producing patterns upon, A. Jackson..... 274,944
Printing machine, E. Anthony..... 275,113
Projectile, E. Palliser..... 275,258
Puddling furnace, J. Bergqvist..... 275,119
Pulverizing machine, H. B. Feldmann..... 275,031
Pump, F. B. Hanson..... 274,937
Pump, L. Patric..... 274,965
Pump rod coupling, O. R. Mehaffey..... 275,065
Punch for nut machines, G. G. McMurtry..... 274,957
Quilting frame, J. Pratt..... 274,967
Rack. See Hay rack.
Railway cattle guard, Dillon & Gartner..... 275,333
Railway crossing, E. Evans..... 275,028
Railway crossing and station signal, W. B. Wood..... 275,318
Railway rails, bar for aligning, R. J. Noonan..... 275,256
Railway signal, automatic, J. S. McLeod..... 275,064
Railway signal, electric, H. C. Nicholson..... 275,255
Railway signal, pneumatic, E. M. Chase..... 275,019
Railway switch, A. Ayres..... 275,115
Railway switch, Gray & Hollenback..... 275,088
Railway ties, wear plate for, D. Servis (r)..... 10,302
Railway track circuits, electrical connector for, S. D. Field..... 275,180
Railway track layer, J. Turner..... 275,096
Reaping machine, W. Gause..... 274,981
Reflector for chandeliers, etc., I. P. Frink..... 274,930
Refrigerating structure, R. H. Waters..... 275,000
Reservoir for waterworks, B. F. Stephens..... 274,987
Rivet, tubular, B. L. D'Aubigné..... 275,153
Roasting and reducing furnace for gold and silver ores, J. E. Rice..... 275,272
Rod. See Gun rod.
Roller mill, Marmon & Warrington..... 275,055
Roller mill sieve, H. J. & G. A. Gilbert..... 275,190
Rolling metal bars, machine for, J. Ostrander..... 274,964
Rolling mill, metal, J. I. Williams..... 275,309
Routing machine, R. T. White..... 275,002
Sash fastener, R. Chandler..... 275,018
Sash, window, R. Langtry..... 275,228
Saw, circular, C. H. Douglas..... 274,922
Sawing machine, H. K. Olsen..... 275,069
Sawing machine, band, W. W. Carey..... 275,139
School chair, O. C. Clark..... 275,021
Scraper, dirt, J. Porteous..... 275,075
Screw cutting tool, J. G. Dalie..... 275,156
Screwdriver, M. B. Crawford..... 274,912
Screwdriver, Mallet & Furbish..... 275,285
Seal lock, A. O. Dayton..... 275,026
Seal lock, R. Frew..... 274,929
Secondary battery element, C. F. Brush..... 274,905

Self-feeding and smoke-consuming furnace, L. W. Sutcliffe..... 274,990  
 Separator, See Starch separator.  
 Sewing machine, C. H. Bayley..... 275,117  
 Sewing machine attachment, P. A. Jones..... 275,048  
 Sewing machine, book, D. M. Smyth..... 274,986  
 Sewing machine buttonhole attachment, J. P. Hallenbeck..... 275,200  
 Sewing machine, hat, V. Moeslein..... 275,067  
 Sewing machines, lamp-supporting bracket for, M. E. Smith..... 274,984  
 Shaving and splitting machine, lap, D. A. Dixon..... 274,921  
 St. ears. See Coupon shears.  
 Sheller. See Corn sheller.  
 Shelves, hanging book, M. S. Drake..... 275,027  
 Shepherd's crook, E. E. Deland..... 275,161  
 Shirt, C. N. Davis..... 274,919  
 Shirt, C. F. Glenn..... 275,191  
 Shoe fastener, E. H. Train..... 275,295  
 Show case, revolving, Stevens & Meeker..... 275,283  
 Shutter bower, J. B. Dunwoody, Jr..... 275,137  
 Signal. See Railway signal.  
 Signaling apparatus, automatic, F. B. Wood..... 275,005  
 Sink, portable, J. Luther..... 274,952  
 Shirt protector, G. A. Blanchard..... 275,014  
 Snap hook, H. S. Pullman..... 275,266  
 Snow banks, device for depositing torpedoes in, G. A. Gunther..... 275,039  
 Snow plow, H. A. Webber..... 275,301  
 Soap compound, C. E. Hore..... 275,212  
 Sole rounding machine, D. F. Hartford..... 274,939  
 Speed indicator, alarm, C. J. Langenbach..... 275,222  
 Spinning machine, thread guide, H. P. Chase..... 275,020  
 Spoon, E. Aldom..... 275,112  
 Sprue for foundry use, J. H. Depew..... 275,332  
 Stamp for crushing ore, steam, E. D. Leavitt, Jr..... 275,224  
 Stand. See Wash stand.  
 Staples, machine for inserting and clinching, L. W. Heysinger..... 274,941  
 Starch separator, W. Allen..... 275,320  
 Starch separator, F. H. Kimball..... 275,340  
 Starch table, W. Allen..... 275,318  
 Starch washing machine, W. Allen..... 275,319  
 Station indicator, S. Forrester..... 274,927  
 Steam street mains, connection well for, E. Brooks..... 275,129  
 Steam, utilizing exhaust, D. Renshaw..... 274,974  
 Stencil plate lock, W. M. Harris..... 275,205  
 Stereotype matrices, machine for making, C. H. Davids..... 274,918  
 Stone sawing machine, A. Folsom..... 274,926  
 Stopping and starting mechanism for intermittent machines, E. Baker..... 275,116  
 Stove and furnace grate, F. O. Hart..... 274,938  
 Stove, hydrocarbon gas, A. M. Brainard..... 275,127  
 Stove, vapor, P. Martin..... 275,058  
 Straw stacker, L. W. Hasselman..... 274,940  
 Sulky, Chandler & Williams..... 275,143  
 Surveying instruments, attachment for transits and other, R. Gibbons..... 275,034  
 Suspension wrench for gas and other cocks, I. W. Heysinger..... 275,042  
 Switch. See Railway switch.  
 Switch lever and rod, H. M. Harper..... 275,336  
 Table. See Starch table.  
 Table leg fastening, H. Rose..... 275,274  
 Target, archery, J. W. C. Alday..... 275,111  
 Tea pot, J. Mitchell..... 275,246  
 Telegraph, automatic printing, A. F. & F. B. Johnson..... 275,339  
 Telegraph, duplex, J. E. Fena..... 275,334  
 Telegraphs, polarized relay for quadruplex, G. W. Gardanier..... 275,185  
 Telegraphic conductors, supporting and preserving, J. H. Green..... 275,195  
 Telegraphy, receiving instrument for quadruplex, S. D. Field..... 275,181  
 Telephone, speaking, S. D. Field..... 275,178  
 Telephone transmitter, E. L. Wilson..... 275,310  
 Telephone circuits, automatic signaling apparatus for, T. N. Vall..... 275,296  
 Thrasher, G. E. Luckey..... 275,052  
 Thrashing and cleaning machine, J. Miller..... 275,244  
 Tilting can, C. T. Draper..... 274,923  
 Tobacco receptacle, E. Mason..... 274,954  
 Toilet set box, F. Zander..... 275,110  
 Tool for grasping and holding, S. B. McLane..... 275,341  
 Tool for grasping and holding articles, T. G. Hall..... 275,335  
 Towel, napkin, etc., holder, C. H. Hershey..... 275,040  
 Toy, Stanton & Reiling..... 275,282  
 Toy block, S. B. Scott..... 274,960  
 Toy milch cow, Mantz & Blum..... 275,053  
 Toy, rotating, D. Heineke..... 275,209  
 Toy savings bank, E. L. Morris..... 275,068  
 Trace fastener, J. S. Miller..... 275,245  
 Traction engine, Snyder & Frick..... 275,279  
 Traction wheel, O. F. Gilbert..... 275,035  
 Transplanter for tobacco and other plants, S. S. Neblett..... 275,253  
 Transportable engine, C. S. Sorenson..... 275,089  
 Trap. See Mole trap. Mole trap.  
 Treadle and connection, Thayer & Smith, Jr..... 274,992  
 Truss pad, G. L. Gerard..... 274,932  
 Tug attachment, harness, J. W. Hill..... 275,043  
 Twist drill, T. Hooker..... 274,943  
 Type, H. H. Thorp..... 274,998  
 Underground conduit, J. Lynch..... 275,233  
 Valve, H. R. Frisbie..... 275,184  
 Valve attachment for gravity lubricators, R. Baird..... 274,894  
 Vaporizer, S. Marcus..... 275,288  
 Vegetable cutter, J. M. Butler..... 275,136  
 Vehicle dash board, W. A. Packard..... 275,257  
 Vehicle, two-wheeled, A. Burkhard..... 275,133  
 Vehicle, two-wheeled, H. T. Seeley..... 275,084  
 Vehicle, two-wheeled, S. M. Wier..... 275,304  
 Vehicle wheel, L. & F. Burnett..... 275,120  
 Ventilator. See Car window ventilator.  
 Vessel unloading apparatus, O. Sherwood..... 274,983  
 Vial or bottle, C. Toussaint..... 274,995  
 Wagon, log, A. W. Cagle..... 275,016  
 Wagon platform gear, E. Clark..... 275,147  
 Wagon reach, M. Deeg..... 275,331  
 Wash stand, W. Blackwood, Jr..... 275,122  
 Washing machine, E. J. C. Kals..... 275,049  
 Washing machine, E. L. Keys..... 274,946  
 Watch case, magic, E. A. Muckle..... 275,251  
 Watch key and cross bar for watch chains, combined, W. F. Brennan..... 274,903  
 Waterproofed building material, treating, R. M. Caffall..... 275,327  
 Water, purifying, G. Seiler..... 275,277  
 Well digging apparatus, B. F. Stephens..... 274,988  
 Wheel. See Paddle wheel. Vehicle wheel.  
 Whitetree hook, J. J. Green..... 275,196  
 Wind engine, G. E. Fletcher..... 275,032  
 Windmill, M. A. Button..... 275,137  
 Windmill attachment, A. G. Carman..... 275,140  
 Windmill, self-regulating, G. K. Glenn..... 275,036  
 Windows, manufacture of colored glass, J. La Farge..... 274,948  
 Wire reeling machine, J. Tynan..... 274,958

Woodworking machines, endless chain bed for, L. P. Hoyt..... 275,218  
 Wrench. See Pipe wrench. Suspension wrench.  
 Wrench, O. E. H. N. Reichling..... 275,079  
 Wringer. See Clothes wringer.

DESIGNS.  
 Buckle, R. G. Hanford, Jr..... 13,882  
 Finger ring, H. D. Sherrill..... 13,840  
 Fringe, S. Steinecke..... 13,841  
 Glassware, A. H. Heisey..... 13,883  
 Jewelry, trimming for articles of, H. G. Mackinney..... 13,836  
 Mantel facing, R. Rossman..... 13,839  
 Spoon or fork handle, M. H. Kinsley..... 13,835  
 Spoon or fork handle, W. Rogers..... 13,838  
 Steam engine, upright, Sweet & Bullock..... 13,842  
 Toy fulminate exploder, E. L. Morris..... 13,837  
 Type, font of, W. W. Jackson..... 13,834  
 Type, font of printing, J. M. Conner..... 13,830  
 Type, printing, G. Giesecke..... 13,831  
 Upholstery trimming, J. C. Copper..... 13,843

TRADE MARK.  
 Crayons, chalk, Parmenter Crayon Company..... 10,154

Advertisements.  
 Inside Page, each insertion --- 75 cents a line.  
 Back Page, each insertion --- \$1.00 a line.  
 (About eight words to a line.)  
 Engravings may head advertisements at the same rate per line, by measurement, as the letter press. Advertisements must be received at publication office as early as Thursday morning to appear in next issue.

No Man need Lack  
 A HOME.  
 FROM ASSOCIATION PLANS



TO BUILD A HOUSE

of any kind, first decide WHAT to build, then HOW to build, by getting our book, which gives a wide range of approved and practical designs from dwellings costing \$500 up to \$20,000. Large quarto, 178 illustrations. A large and handsome publication, profusely illustrated, interesting to any reader, and of peculiar interest to an intending builder, as it is calculated to save him time, labor, and money. N. Y. Weekly Witness. "We have thoroughly examined the work, which proves to be of great interest to those intending to build, and we consider it a practical scheme and a responsible association."—Christian at Work. "Practical, beautiful, and economical plans. The wonder is that a publication of this kind has not been issued before."—N. Y. Weekly Witness. The only low-priced architectural book, and the most helpful building scheme ever offered. Price 50c, by mail, postpaid. Stamps taken. Money returned if not satisfied. CO-OPERATIVE BUILDING PLAN ASSOCIATION, 24 Beekman St. (Box 2,702), New York.

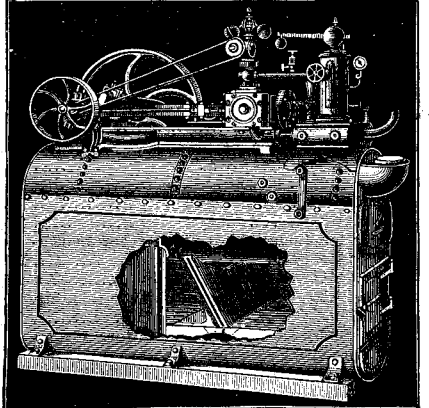

PORTABLE AND STATIONARY ENGINES AND BOILERS, 5 to 20 H. P. Return Flue Boiler, large Fire Box, no sparks. Do not fail to send for circular to SKINNER & WOOD, Erie, Pa.

STRAIGHT LINE ENGINE CO. SYRACUSE, N.Y. STRICTLY FIRST CLASS AUTOMATIC ENGINE OF FROM TEN TO SIXTY HORSE POWER.

Lowest Price  
**PLANER**  
 AND  
**CHEAPEST**  
 FOR THE MONEY.  
 With Buzz Attachment or without. Also manufacturers of the Double Acting Water Rams

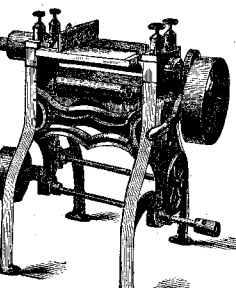

C. Hodgkins & Son, Marlboro, N. H.  
**WESTCOTT'S**  
**Chucks**  
 WARRANTED SUPERIOR TO ANY IN THE WORLD  
 In capacity, strength, durability, and convenience. Oneida Steam Engine and Foundry Company, Send for Price List. ONEIDA, N. Y.

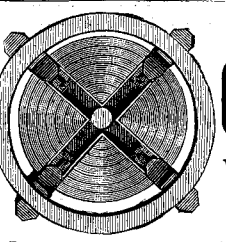

TAPS & DIES  
 VISES  
 MACHINES  
 SCREWS  
 LATHES  
 FILES  
 STEEL  
 STOPS  
 SUBS

TOOLS for Machinists, Amateurs, Jewellers, Model Makers, Blacksmiths, Carpenters, Coachmakers, etc. Send 20 cts. for new Metal Worker's Catalogue, 300 Pages. Wood Worker's Catalogue free. TALLMAN & McFADDEN, Philadelphia, Pa.

**THE RIDER HOT AIR COMPRESSION Pumping Engine,**  
 For city and country residences where it is required to raise a supply of water.  
 Simple, Economical, Effective.  
 No skill required to run it. We can refer to our customers of eight years' standing. Send for catalogue.  
 CARMeyer & SAYER,  
 93 Liberty St., New York,  
 Will remove, May 1, to 19 Dey St.



**Valuable Manufacturing Property AT AUCTION.**

If not sold privately, the undersigned will, on 6th of June, 1883, sell at auction, at Bagg's Hotel, Utica, N. Y., at 2 P.M., the property formerly belonging to the Paris Furnace Company, located at Clayville.  
 This property consists of two separate mills or shops, one with steam, and each with good water power, full line of shafting, etc.  
 Attached to the works are shops, offices, residence, and twenty-four acres of land.  
 They are on the line of the D., L. & W. R. R., ten miles from Utica. Were formerly used for the manufacture of hoes, forks, scythes, etc., but can be readily adapted to any purpose. Taxation light. Coal and labor secured at lowest rates.  
 The owners will let the property go at a great sacrifice, and to any one desirous of engaging in manufacturing no better location can be found.  
 If not sold as an entirety, the manufacturing establishments will be offered separately.  
 Terms, one-third cash; balance on bond and mortgage, at 5 per cent., if desired.  
 For particulars and description, address  
**H. C. SHOLES, Att'y at Law,**  
 Clayville, N. Y.

SEND TO LONDON, BERRY & ORTON  
 PHILAPA FOR  
**THE BEST BAND SAW BLADE**

ORNAMENTAL METAL PATTERNS, Moulds and Dies, Modeling, Designing, etc. Contracts taken for the manufacture of all kinds of soft metal goods. CHAS. A. BAILEY, Middletown, Ct.

**GUNS** Bargains.  
 SEND US your address on a postal card, and we will furnish you, free, our large illus. 10c. catalogue. Hundreds of fine engravings. Everything in the gun line, watches, cutlery, etc., at low prices. Address G. W. TURNER & ROSS, 16 & 17 Duck St., Boston, Mass.

**WATCHMAKERS.**  
 Before buying lathes, see the "Whitecomb," made by AMERICAN WATCH TOOL CO., Waltham, Mass.

**ROOFING.**  
 For steep or flat roofs. Applied by ordinary workmen at one-third the cost of tin. Circulars and samples free. Agents Wanted. T. NEW, 32 John Street, New York.

NEW YORK STENCIL WORKS  
**STEEL LETTERS**  
**STAMPS**  
 STEEL DIES & C.  
 100 NASSAU ST. N.Y.

**UNIVERSAL**  
 Pulverizes everything—hard, soft, gummy, etc. The best Clay Grinder and the best Cotton Seed Muller in the world.  
 Portable Steam Engines, Stationary Engines, Horizontal and Upright Boilers, all sizes, on hand for immediate delivery.  
 34 Cortlandt, after 1st May 10 Barclay St., N. Y. City.

Steam Engine for Sale.—One second-hand Porter M'F Co. 50 H. P. Engine, built in 1882, used but eight months, with all modern improvements. Good as new. Address COLLINS ARNOLD, 55 Federal St., Troy, N. Y.

**KEMP'S MANURE SPREADER, PULVERIZER and CART COMBINED.**  
 Greatest Agricultural invention of the age. Saves 50 per cent. of labor, and doubles the value of the manure. Spreads evenly all kinds of manure broadcast or in drill, in one-third the time required by hand.  
 Send for Illustrated Catalogue and full particulars to KEMP & BURFEE M'F CO., Syracuse, Onondago Co., N. Y.



Huguenin Improved Sash Balances are not catches, but mechanical substitutes for weights, at quarter their applied cost, for buildings, steamboats, cars, etc. Write R. B. Huguenin, Sole Maker, Hartford, Ct., for particulars.

**NATIONAL TOOL CO.,**  
 MANUFACTURERS OF MACHINISTS TOOLS. WILLIAMSPORT PA. PLANERS A SPECIALTY.



**THE SEIBERT CYLINDER OIL CUP CO.,**  
 Sole Manufacturers of Oil Cups for Locomotives, Marine and Stationary Engine Cylinders, under the Seibert and Gates Patents, with Sight Feed.



**THE SEIBERT CYLINDER OIL CUP CO.,**  
 53 Oliver Street, Boston, Mass.

TAKE NOTICE.  
 The "Sight Feed" is owned exclusively by this company. See Judge Lowell's decision in the United States Circuit Court, District of Massachusetts, Feb. 23, '82. All parties are hereby notified to desist the use, manufacture, or sale of same, as we shall vigorously pursue and prosecute all infringers.

**J. A. FAY & CO.,**  
 Cincinnati, Ohio, U.S.A.  
**WOOD WORKING MACHINERY**  
 Embracing nearly 300 different tools for arsenals, Navy Yards, Car Shops, Bridge Works, Saw and Planing Mills, Door, Sash, Furniture, Piano & Organ factories, etc. Including Sawing, Planing, Molding, Mortising, Tenoning, Shaping, Polishing, etc. of the highest standard of excellence, and warranted the most labor saving of any in use.  
 W. H. Doane, President. D. E. Lyon, Secy.

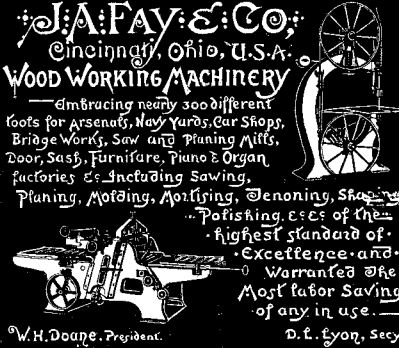

**Elements of Construction for ELECTRO-MAGNETS**  
 By Count Th. Du Moncel. Translated by C. J. Warton. Crown 8vo, cloth, 75 cents.  
 USEFUL INFORMATION on Electric Lighting. By K. Hedges. Fourth edition. Illustrated. Crown 8vo, cloth, \$1.75.  
 ELECTRIC LIGHTING by Water Power. By T. B. Grierson. 8vo, paper, 40 cents.  
 LECTURES ON THE STORAGE OF ENERGY. By Prof. Ayrton. 8vo, paper, 20 cents.  
 List of Electrical Books sent on application.  
**E. & F. N. SPON, 44 MURRAY ST., NEW YORK.**

WANTED.—Price and particulars of small boilers from five to twenty horse power. Address THE UNION SWITCH & SIGNAL CO., Pittsburg, Pa.



DEAFENING  
 FIRE AND VERMIN PROOF  
 Sample and Circular Free by mail.  
**U. S. MINERAL WOOL CO., 22 Courtlandt St., N. Y.**

**CARY & MOEN**  
 STEEL WIRE OF ALL DESCRIPTIONS  
 234 W. 29 ST. EVERY & STEEL SPRINGS, NEW YORK CITY



CATALOGUES FREE TO ANY ADDRESS  
**TOOLS OF ALL KINDS**  
 GOODNOW & WIGHTMAN BOSTON



**FEED WATER HEATERS.**  
 THE BEST AND CHEAPEST IN THE MARKET.  
 Warranted to heat water by exhaust steam from 200° to 212° Fahrenheit.  
 For description and price, apply to THE NATIONAL PIPE BENDING CO., New Haven, Conn.

**COE BRASS MFG. CO.**  
 BRASS TORRINGTON, CONN. WIRE AND MATERIALS FOR METALLIC IN SHEETS, AMMUNITION A SPECIALTY.

**MALLEABLE** AND FINE GRAY IRON ALSO STEEL CASTINGS FROM SPECIAL FINE TUNING JAPANNING PATTERNS FINISHING LEHIGH AVE. & AMERICAN ST. PHILA.

**Self-Oiling Loose Pulley.**  
 Fully tested by several years' use and found reliable.  
**SATISFACTORY RESULTS**  
 guaranteed, if directions are followed. Orders filled for Pulleys from 6 in. to 20 in. diameter.  
**LANE & BODLEY CO.,**  
 CINCINNATI, OHIO, MANUFACTURERS  
 Shafting, Steam Engines, Boilers, SAW MILLS, AND GENERAL MACHINERY.

**PATENTS.**  
 MESSRS. MUNN & CO., in connection with the publication of the SCIENTIFIC AMERICAN, continue to examine Improvements, and to act as Solicitors of Patents for Inventors.  
 In this line of business they have had thirty-eight years' experience, and now have unequalled facilities for the preparation of Patent Drawings, Specifications, and the prosecution of Applications for Patents in the United States, Canada, and Foreign Countries. Messrs. Munn & Co. also attend to the preparation of Caveats, Copyrights for Books, Labels, Reissues, Assignments, and Reports on Infringements of Patents. All business entrusted to them is done with special care and promptness, on very reasonable terms.  
 A pamphlet sent free of charge, on application, containing full information about Patents and how to procure them; directions concerning Labels, Copyrights, Designs, Patents, Appeals, Reissues, Infringements, Assignments, Rejected Cases, Hints on the Sale of Patents, etc.  
 We also send, free of charge, a Synopsis of Foreign Patent Laws, showing the cost and method of securing patents in all the principal countries of the world.  
**MUNN & CO., Solicitors of Patents,**  
 361 Broadway, New York.  
 BRANCH OFFICE—Corner of F and 7th Streets, Washington, D. C.

UNITED STATES MUTUAL ACCIDENT ASSOCIATION

\$5,000 Accident Insurance, \$25 Weekly Indemnity. Membership Fee, \$4. Annual cost about \$11. \$10,000 Insurance, with \$50 Weekly Indemnity, at Corresponding Rates. Write or call for Circular and Application Blank. EUROPEAN PERMITS WITHOUT EXTRA CHARGE. CHAS. B. PEET, President. (Of Rogers, Peet & Co.) JAS. R. FITCHER, Sec'y. 320 & 322 BROADWAY, NEW YORK.

MUSIC 84-page illustrated catalogue, with words and music of 26 popular songs, and handsome clear-cutting, all for 12c. 100 choice songs, words, music, and accompaniments; or, 100 popular pieces for Piano or Organ, all full sheet music size, .50c. Diamond School for Violin, 558 pieces, 50c. Comic, English, Ethiopian, Home, Irish, Old, Opera, Popular, Scotch and Sentimental songs, words and music, 100 of each, 30c., or 400 for \$1.00. 50 contras, figs, reels, breakdowns, &c., for piano or organ, 50c. F. TRIFET, 27 School Street, Boston, Mass.

FOR SALE—A financially paying weekly in a live enterprising manufacturing town. A large run of first-class paying job work. Change of business. Terms liberal; but little cash required. Address C. E. BROWN, Silver Creek, N. Y.

WANTED—Situation by Foreman Blacksmith, thoroughly acquainted with Drop, Trip-hammer, and other machine forming, Punching Press work and Die Sinking, also a good draughtsman. Address B. F. S., 75 Pynchon St., Springfield, Mass.

\$68 a week in your own town. Terms and \$5 outfit free. Address H. HALLET & Co., Portland, Me.

CARLETON'S TREASURY OF KNOWLEDGE, THE BEST SELLING BOOK EVER KNOWN. The largest discount. Circulars free. Agents address G. W. Carleton & Co., Publishers, N. Y.

AGENTS can now grasp a fortune. Outfit worth \$10 free. Address E. G. RIDEOUT & CO., 10 Barclay St., N. Y.

25 Imported design Chromo Cards for 1883, name on, 10c. Quality not quantity. Warranted best sold. Bonanza for agents. FRID L. JONES, Nassau, N. Y.

WANTED to manufacture and sell on royalty, some good article suitable for the notion trade. If article is satisfactory, we will sell it in every city in the U. S. Send sample to E. IVINS, 932 Spring Garden St., Philadelphia, Pa.

50 Elegant large chromos, no 2 alike, name on, 10c. present with each order. O. A. Brainard, Higganum, Ct.

\$30,000 HOW \$2 INVESTED brings \$30,000. A fortune within the reach of A. J. L. Circulars with FULL information sent FREE by addressing CHAS. MEEKIN, Courier Journal Building, Louisville, Ky.

\$5 to \$20 per day at home. Samples worth \$5 free. Address STINSON & Co., Portland, Me.

ALYON & HEALY State & Monroe Sts., Chicago. Will send prepaid to any address their BAND CATALOGUE, for 1883, 400 pages, 210 Engravings of Instruments, Suites, Caps, Belts, Compons, Epauls, Cap-lamps, Stands, Drum, Malar's Staffs, Hats, Sundry Band Outfits, Repairing Materials, also includes Instruction and Exercises for Amateur Bands, and a Catalogue of Choice Band Music.

KEUFFEL & ESSER, NEW YORK. Prepared Blue Process Papers. Papers for Blue Process (Unprepared). Our Papers will keep for a long time. Always fresh made when ordered. Quality warranted. Send for Circulars and Samples.

STEWART'S READY ROOFING For STEEP and FLAT ROOFS of all kinds; can be applied by ordinary workmen at ONE THIRD the cost of TIN. Send for a sample and our circular which gives full directions how to apply your own roof; also how to repair leaky roofs of all kinds. Address, W. H. STEWART, 74 Cortlandt St., New York.

MANHOOD! THE SCIENCE OF LIFE KNOW THYSELF. A Book for Every Man! Young, Middle-Aged, and Old. The untold miseries that result from indiscretion in early life may be alleviated and cured. Those who doubt this assertion should purchase and read the new medical work published by the Peabody Medical Institute, Boston, entitled the Science of Life; or Self-Preservation. It is not only a complete and perfect treatise on Manhood, Exhausted Vitality, Nervous and Physical Debility, Premature Decline in Man, Errors of Youth, etc., but it contains one hundred and twenty-five prescriptions for acute and chronic diseases, each one of which is invaluable, so proved by the author, whose experience for 21 years is such as probably never before fell to the lot of any physician. It contains 300 pages, bound in beautiful embossed covers, full gilt, embellished with the very finest steel engravings, guaranteed to be a finer work in every sense—mechanical, literary, or professional—than any other work retailed in this country for \$2.50, or the money will be refunded. Price only \$1.25 by mail. Gold medal awarded the author by the National Medical Association. Illustrated sample sent on receipt of six cents. Send now. Address PEABODY MEDICAL INSTITUTE, or DR. W. H. PARKER, No. 4 Bulfinch Street, Boston, Mass. The author may be consulted on all diseases requiring skill and experience.

BEATTY'S PARLOR ORGANS ONLY \$49.75

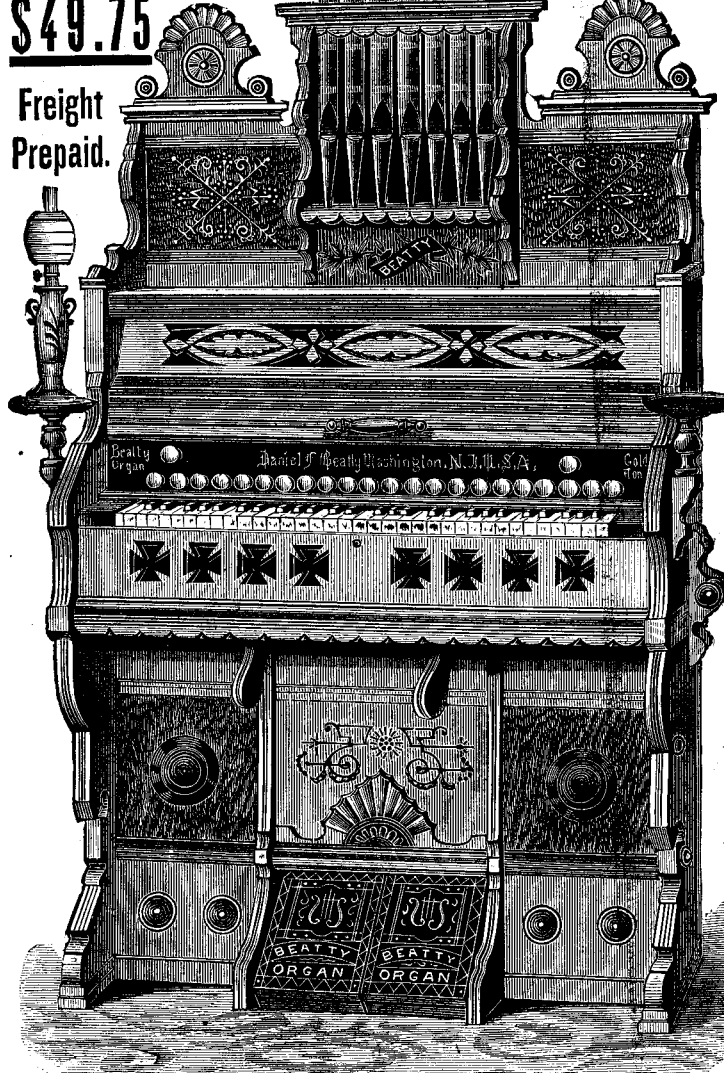

Latest Style, No. 1526. Dimensions—Height, 74 ins., Depth, 26 ins., Length, 50 ins., Weight, boxed, about 450 lbs. Regular Price \$95.00 Without Stool, Book and Music, 25 STOPS.—1. Cello, 8 ft. tone; 2. Melodia, 8 ft. tone; 3. Clarabella, 8 ft. tone; 4. Manual Sub-Bass, 16 ft. tone; 5. Bourdon, 16 ft. tone; 6. Saxophone, 8 ft. tone; 7. Viol di Gamba, 8 ft. tone; 8. Diapason, 8 ft. tone; 9. Viola Dolce, 4 ft. tone; 10. Grand Expressione, 8 ft. tone; 11. French Horn, 8 ft. tone; 12. Harp Aeolian; 13. Vox Humana; 14. Echo, 8 ft. tone; 15. Dulciana, 8 ft. tone; 16. Clarinet, 8 ft. tone; 17. Vox Celeste, 8 ft. tone; 18. Violins, 4 ft. tone; 19. Vox Jubilante, 8 ft. tone; 20. Piccolo, 4 ft. tone; 21. Coupler Harmonique; 22. Orchestral Forte; 23. Grand Organ Knee Stop; 24. Right Organ Knee Stop. This Organ is a triumph of the organ-builder's art. IT IS VERY BEAUTIFUL IN APPEARANCE, BEING EXACTLY LIKE CUT. The Case is solid Walnut, profusely ornamented with hand-carving and expensive fancy veneers. The Pipe-Top is of the most beautiful design extant. It is deserving of a place in the millionaire's parlor, and would ornament the boudoir of a princess. FIVE SETS REEDS.—Five Octaves, handsome appearance. It will not take the dirt or dust. It contains the Sweet VOIX CELESTE STOP, the famous French Horn Solo Combination, New Grand Organ Right and Left Knee Stops, to control the entire motion by the Knee, if necessary. Five (5) Sets of GOLDEN TONGUE REEDS, as follows: a set of powerful Sub-Bass Reeds; set of 3 Octaves of VOIX CELESTE; one set of FRENCH HORN REEDS, and 2-1/2 Octaves each of regular GOLDEN TONGUE REEDS. Besides all this it is fitted up with OCTAVED COUPLER, which doubles the power of the instrument, Lamp Stands, Pocket for Music, Beatty's Patent Stop Action, also Sounding Boards, &c. It has a Sliding Lid and conveniently arranged Handles for moving. The Bellows, which are of the upright pattern, are made from the best quality of rubber cloth, are of great power, and are fitted up with steel springs and the best quality of pedal straps. Instead of being covered with carpet, are polished metal of neat design, and never get out of repair or worn. SPECIAL TEN-DAY OFFER TO READERS OF SCIENTIFIC AMERICAN. If you will remit me \$49.75 and the annexed Coupon within 10 days from the date hereof, I will box and ship you this Organ, with Organ Bench, Book, etc., exactly the same as I sell for \$95. You should order immediately, and in no case later than 10 days. One year's test trial given and a full warranty for six years. GIVEN UNDER MY HAND AND SEAL.

THE 26th DAY OF APRIL, 1883. Daniel F. Beatty

COUPON On receipt of this Coupon from any readers of THE SCIENTIFIC AMERICAN, \$45.25 and \$49.75 in cash by Bank Draft, Post Office Money Order, Registered Letter, Express prepaid, or by Check on your Bank, if forwarded within 10 days from date hereof, I hereby agree to accept this Coupon for \$45.25 as part payment on my celebrated 24 Stop \$95 Parlor Organ, with Bench, Book, etc., providing the cash balance of \$49.75 accompanies this Coupon, and I will send you a receipted bill in full for \$95, and box and ship you the Organ just as it is advertised, fully warranted for six years. Money refunded with interest from date of remittance if not as represented after one year's use. (Signed) DANIEL F. BEATTY.

FREIGHT PREPAID. As a further inducement for you, (provided you order within 10 days) I agree to prepare freight on the above Organ to your nearest railroad freight station any point east of the Mississippi River, or that far on any going west of it. This is a rare opportunity to place an instrument, as it were, at your very door, all freight prepaid, at manufacturer's wholesale prices. Order now; nothing saved by correspondence. HOW TO ORDER. Enclose the \$49.75 for Organ, Bench, Book, etc., in payment of this advertisement and I order one or more condition that it must prove exactly as represented in this advertisement, or I shall return it at the end of one year's use and demand the return of my money, with interest from the very moment I forwarded it, at six per cent, according to your offer. Be very particular to give name, Post Office, County, State, Precinct, station, and on what Railroad. Express prepaid, or by Bank Check, P. O. Money Order, Registered Letter, Express prepaid, or by Bank Check. You may accept by telegraph on last day and remit by mail on that day, which will secure this special offer. I desire this magnificent instrument introduced without delay, hence this price, providing order is given immediately. Address or call upon the Manufacturer DANIEL F. BEATTY, Washington, New Jersey

The Electric Motor

For Family Sewing Machines, Dental, Jewelers', Watchmakers' Lathes, Fans, etc. Motor, with automatic battery and complete outfit for sewing machine, \$35 to \$40. THE ELECTRO-DYNAMIC CO. OF PHILA., 121 So. 3d St., Phila. 19 E. 15th St., Cannon St., London, Eng. In writing for catalogue, give street and number.

CHASE'S IMPROVED LIQUID GLUE, For Cementing Wood, Glass, Jewelry, Crockery, Furniture, Leather, Ornaments, and Brics-a-brac of every description. Every bottle has a nice Cap and Brush ready for immediate use. This Glue is packed in 2 oz. bottles, and in screw-top cans, and is warranted not to deteriorate with age, either before or after use. It is a GIANT IN STRENGTH, economical, and once carefully-tried, you will never be without it. HOLWAY, WRIGHT & RICH, Sole Agents, BOSTON, NEW YORK, BALTIMORE. 135 State Street. 167 Chambers Street. 4 Commerce Street.

Photo-Engraving

ELECTROTYPE RELIEF PLATES SUPERIOR SUBSTITUTE FOR WOOD ENGRAVING AT MUCH LOWER RATES. 20 Canal Street New York. SEND THREE CENT Stamp FOR ILLUSTRATED CIRCULAR. THE ONLY METHOD OF PHOTO ENGRAVING THAT PRINTS SATISFACTORY.

DROP FORGINGS BILLINGS & SPENCER CO. HARTFORD, CONN. U.S.A. ICE MAKING MACHINES, And Machines for Cooling Breweries, Pork Packing Establishments, Cold Storage Warehouses, Hospitals, etc. SEND FOR ILLUSTRATED AND DESCRIPTIVE CIRCULARS. PICTET ARTIFICIAL ICE CO. (Limited), P. O. Box 3083. 142 Greenwich St., New York City, N. Y.

CONTINENTAL WORKS, BROOKLYN, N. Y. DUC'S MECHANICAL ATOMIZER OR PULVERIZER. For reducing to an impalpable powder all kinds of hard and brittle substances, such as QUARTZ, EMERY, CORUNDUM, GOLD AND SILVER ORES, BARTES, COAL, PHOSPHATE ROCK, etc. It is simple and not liable to get out of order, revolving shell being constructed of Siemens-Martin steel, and all parts mechanical in design and of first-class construction. Weight, 5,500 lb.; heaviest piece, 1,500 lb. It will pulverize 7 TO 10 TONS IN TEN HOURS with 30 H. P. For circulars and full particulars, apply to or address THOS. F. ROLAND, Sole Manuf'r, Brooklyn, N. Y. HENDERSON'S SPECIAL REFRACTORY COMPOUNDS. SUBSTITUTES FOR FIRE BRICK. Costs less than common red brick. Practically infusible. Can be made in any locality where sand is found. No capital for machinery necessary. Any one can handle them. Repairs made by same material. Specially advantageous for Iron, Steel, Silver, and Lead Smelting Works; also for inner walls of FIREPROOF BUILDINGS. For particulars of manufacture and license to use, apply to JAMES HENDERSON, Bellefonte, Penn.

ROOT'S NEW IRON BLOWER

IRON REVOLVERS, PERFECTLY BALANCED, Has Fewer Parts than any other Blower. P. H. & F. M. ROOTS, Manufacturers, CONNERSVILLE, IND. S. S. TOWNSEND, Gen. Agt., 6 Cortland St., 8 Dey St., COOKE & CO., Selling Agts., 6 Cortland Street, JAS. BIGGS & CO., Selling Agts., 8 Dey Street, NEW YORK. SEND FOR PRICED CATALOGUE.

NAVAL Agents Wanted for BATTLES. New and Graphic Pictorial History of the great Sea fights of the World. By Medical Director SHIPPEN S. N. J. C. MCCURDY & Co., 62 Chestnut St., Philadelphia, Pa.

THE BIGGEST THING OUT Illustrated Book Sent Free. (new) E. NASON & CO., 111 Nassau St., New York. Agents Wanted Sells Rapidly. C4S50 S. M. SPENCER, 112 Wash'n St., Boston, Mass. Particulars free

DYKE'S BEARD ELIXIR. For the purpose of restoring the hair to its natural color, and preventing its falling out. It is a perfect remedy for the disease of the hair, and is the only one that will cure it. It is a perfect remedy for the disease of the hair, and is the only one that will cure it. It is a perfect remedy for the disease of the hair, and is the only one that will cure it. A. L. SMITH & CO., Sole Agts., Palatine, Ill.

OPIUM and WHISKY HABITS cured at home without pain. Book of particulars sent free. B. M. WOOLLEY, M.D., Atlanta, Ga.

IT PAYS to sell our Hand Rubber Stamps. Samples free. FOLJAMBE & CO., Cleveland, O.

I CURE FITS! When I say cure I do not mean merely to stop them for a time and then have them return again, I mean a radical cure. I have made the disease of FITS, EPILEPSY or FALLING SICKNESS a life-long study. I warrant my remedy to cure the worst cases. Because others have failed is no reason for not now receiving a cure. Send at once for a treatise and a Free Bottle of my infallible remedy. Give Express and Post Office. It costs you nothing for a trial, and I will cure you. Address Dr. H. G. ROOT, 183 Pearl St., New York.

RUPTURE cured without an operation or the injury trusses inflict by Dr. J. A. SHERMAN'S method. Office, 251 Broadway, New York. His book, with Photographic likenesses of bad cases, before and after cure, mailed for 10c.

MORPHINE AND WHISKEY Habits easily cured with my DOUBLE CHLORIDE OF GOLD REMEDIES. 5,000 cures. Books FREE. LESLIE E. KEELEY, M.D., Surgeon C. & A. Railroad. Dwight, Ill. \$72 A WEEK, \$12 a day at home easily made. Costly Outfit free. Address TRUX & Co., Augusta, Me.

CONSUMPTION. I have a positive remedy for the above disease; by its use thousands of cases of the worst kind of lung standing have been cured. Indeed, so strong is my faith in its efficacy that I will send TWO BOTTLES FREE, together with a VALUABLE TREATISE on this disease, to any sufferer. Give Express & P. O. address, DR. T. A. SCOTT, 181 Pearl St., N. Y.

Advertisements.

Inside Page, each insertion --- 75 cents a line. Back Page, each insertion --- \$1.00 a line. (About eight words to a line.) Engravings may head advertisements at the same rate per line, by measurement, as the letter press. Advertisements must be received at publication office as early as Thursday morning to appear in next issue.

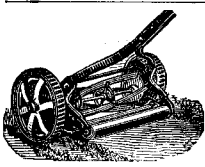

"BUCKEYE" LAWN MOWER. The lightest and easiest running Mower ever made. STRICTLY FIRST CLASS. MAST, FOOS & CO., Springfield, Ohio. Send for catalogue.

ONE THOUSAND TONS METALLIC SHINGLES

Are now being used by the W. S. and B. R. R. on depots between New York and Buffalo. Manufactured by the ANGLO-AMERICAN ROOFING CO., 22 CLIFF STREET, NEW YORK, And 221 Dudley Road, Wolverhampton, Eng.



FIRMENICH SAFETY STEAM BOILERS. CATALOGUE SENT FREE. GEO. C. MORGAN & CO. MANFRS., 16 MAJOR BLK. CHICAGO.

The "MONITOR." A NEW LIFTING AND NON-LIFTING INJECTOR.

Best Boiler Feeder in the world. Greatest Range yet obtained. Does not Break under Sudden Changes of Steam Pressure. Also Patent

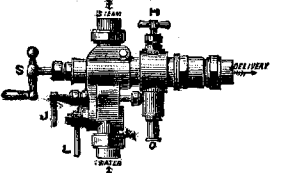

EJECTORS OR Water Elevators. For Conveying Water and Liquid. Patent Office, Lubricators, etc. NATHAN & DRBYUS, 92 & 94 Liberty St., New York.

WM. A. HARRIS. PROVIDENCE, R. I. (PARK STREET), Six minutes walk West from station. Original and Only builder of the HARRIS-CORLISS ENGINE With Harris' Patented Improvements, from 10 to 1,000 H. P.

Diamonds and Carbon

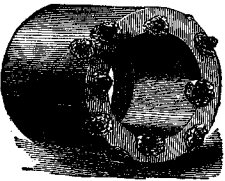

For all kinds of Mechanical Purposes. Carbon for Mining Drills A SPECIALTY. Best quality at the lowest price. The Oldest Established House in the U. S. J. DICKINSON, 64 Nassau Street, NEW YORK.

NEW HAVEN MANUFACTURING CO. NEW HAVEN, CONN., MANUFACTURERS OF IRON WORKING MACHINE TOOLS Lathes, Planers, Drills, Shapers, etc. ILLUSTRATED CATALOGUE ON APPLICATION.

PAYNE'S AUTOMATIC ENGINES.

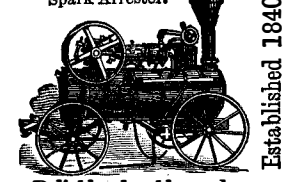

Spark Arrester. Established 1840.

Reliable, durable, and economical, will furnish a horse power with one-third less fuel and water than any other engine built, not fitted with an automatic cut-off. Send for Illustrated Catalogue "A 2" for information and prices. Box 1207 B. W. PAYNE & SONS, Corning, N. Y.

COLUMBIA BICYCLE. This easy running, staunch and durable roadster is the favorite with riders, and is confidently guaranteed as the best value for the money attained in a Bicycle. Send 3c. stamp for 36-page catalogue, containing price list and full information. THE COLUMBIA BICYCLE CO., 507 Washington St., Boston, Mass.

H.W. JOHNS' ASBESTOS

ASBESTOS ROPE PACKING, ASBESTOS WICK PACKING, ASBESTOS PLAT PACKING, ASBESTOS SHEATHINGS, ASBESTOS GASKETS, ASBESTOS BUILDING FELT. Made of strictly pure Asbestos. H. W. JOHNS M'FG CO., 87 Maiden Lane, New York, Sole Manufacturers of H. W. Johns' Genuine ASBESTOS LIQUID PAINTS, ROOF PAINTS, ROOFING, STEAM PIPE AND BOILER COVERINGS, FIREPROOF COATINGS, CEMENTS, ETC. Descriptive price lists and samples free.

ROCK DRILLS & AIR COMPRESSORS. INCERSOLL ROCK DRILL CO., 1 PARK PLACE, NEW YORK.

Pyrometers. For showing heat of Ovens, Hot Blast Pipes, Boiler Flues, Superheated Steam, Oil Stills, etc. HENRY W. BULKLEY, Sole Manufacturer, 149 Broadway, New York.

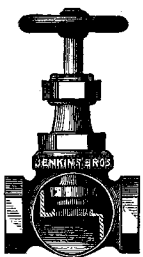

JENKINS PATENT VALVES

GATE, GLOBE, ANGLE, CHECK, AND SAFETY. Manufactured of Best Steam Metal. We claim the following advantages over all other Valves and Gauge Cocks now in use: 1. A perfectly tight Valve under any and all pressures of steam, oils, or gases. 2. Sand or grit of any kind will not injure the seat. 3. You do not have to take them off to repair them. 4. They can be repaired by any mechanic in a few minutes. 5. The elasticity of the Disk allows it to adapt itself to an imperfect surface. In Valves having ground or metal seats, should sand or grit get upon the seat it is impossible to make them tight except by regrinding, which is expensive if done by hand, and if done by machine soon wears out the valve; and in most cases they have to be disconnected from the pipes, often costing more than a new valve. The Jenkins Disk used in these Valves is manufactured under our 1880 Patent, and will stand 200 lb. steam. Sample orders solicited. All Valves sold by us are warranted and are stamped. JENKINS BROS., 71 John Street, New York. Send for Price List A. 79 Kilby Street, Boston.

Established EAGLE ANVILS: 1843. Solid CAST STEEL Face and Horn. Are Fully Warranted. Retail Price, 10 cts. per lb.

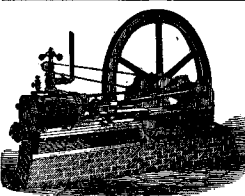

CROWELL MANUFACTURING CO. Greencastle, Penn., Manufacturers of Engines, Boilers, and Saw Mills. Stationary Engines for Mills and Factories. Grain and Fertilizer Drills a specialty. Correspondence solicited.

THE MEDART PATENT WROUGHT RIM PULLEY,

MADE BY McMURRAY & STUGHTON, HARTFORD, CONN.

EJECTOR CONDENSER FOR STEAM ENGINES OR VACUUM PANS.

Elevated, or low down. Gives highest range of Vacuum, always in Order, easily Applied, Reliable and Cheap. For Circulars or personal visit, address J. L. ALBERGER, Buffalo, N. Y., or T. SAULT, New Haven, Conn.

BOGARDUS' PATENT UNIVERSAL ECCENTRIC MILLS. For grinding Bones, Ores, Sand, Old Crucibles, Fire Clay, Guanos, Oil Cake, Feed, Corn and Cob, Tobacco, Snuff, Sugar, Salts, Roots, Spices, Coffee, Coconut, Flaxseed, Asbestos, Mica, etc., and whatever cannot be ground by other mills. Also for Paints, Printers' Inks, Paste, Blacking, etc. JOHN W. THOMSON, successor to JAMES BOGARDUS, corner of White and Elm Sts., New York.

PATENT JACKET KETTLES, Plain or Porcelain Lined. Tested to 100 lb. pressure. Send for Lists. JAMES C. HEND & CO., 614 and 616 Market St., Philadelphia, Pa.

NEW YORK BELTING AND PACKING COMPY.

The Oldest and Largest Manufacturers of the Original SOLID VULCANITE EMERY WHEELS. All other kinds Imitations and Inferior. Our name is stamped in full upon all our standard BELTING, PACKING, and HOSE. JOHN H. CHEVREK, Treas., 29 PARK ROW, NEW YORK. SPECIAL NOTICE. Owing to the recent great fire in the "World" Building, our office has been removed as above.

ERICSSON'S New Caloric Pumping Engine, FOR Dwellings & Country Seats Simplest! Cheapest! Economical! Absolutely Safe! Delamater Iron Works, C. H. Delamater & Co., Proprietors, 16 Cortlandt Street, New York, U. S. A.

TIGHT & SLACK BARREL MACHINERY A SPECIALTY JOHN GREENWOOD & CO. ROCHESTER N. Y.

SPEAKING TELEPHONES.

THE AMERICAN BELL TELEPHONE COMPANY, W. H. FOUBES, W. R. DRIVER, THO. N. VAIL, President, Treasurer, Gen. Manager. Alexander Graham Bell's patent of March 7, 1876, owned by this company, covers every form of apparatus, including Microphones or Carbon Telephones, in which the voice of the speaker causes electric undulations corresponding to the words spoken, and which undulations produce similar articulate sounds at the receiver. The Commissioner of Patents and the U. S. Circuit Court have decided this to be the true meaning of his claim; the validity of the patent has been sustained in the Circuit on final hearing in a contested case, and many injunctions and final decrees have been obtained on them. This company also owns and controls all the other telephonic inventions of Bell, Edison, Berliner, Gray, Blake, Phelps, Watson, and others. (Descriptive catalogues for ward on application.) Telephones for Private Line, Club, and Social systems can be procured directly or through the authorized agents of the company. All telephones obtained except from this company, or its authorized licensees, are infringements, and the makers, sellers, and users will be proceeded against. Information furnished upon application. Address all communications to the AMERICAN BELL TELEPHONE COMPANY, 95 Milk Street, Boston, Mass.

CLARK'S RUBBER WHEELS. This Wheel is unrivaled for durability, simplicity, and cheapness. Adapted for Warehouse and Platform Trucks, Scales, Heavy Casters, and all purposes for which Wheels are used. Circular and Price List free. GEO. P. CLARK, Windsor Locks, Ct.

VOLNEY W. MASON & CO., FRICTION PULLEYS, CLUTCHES, and ELEVATORS, PROVIDENCE, R. I.

ROCK BREAKERS AND ORE CRUSHERS. We manufacture and supply at short notice and lowest rates, Stone and Ore Crushers containing the invention described in Letters Patent, issued to E. W. Blake, June 15th, 1878, together with New and Improved Inventions, for which Letters Patent were granted May 14th and July 20th, 1880. Mr. S. L. Marsden, All Crushers supplied by us are constructed under the superintendence of Mr. Marsden, who, for the past fifteen years, has been connected with the manufacture of Blake Crushers in this country and England. FARREL FOUNDRY AND MACHINE CO., Manuf'rs., Ansonia, Conn. COPELAND & BACON, Agents, New York.

ELECTRIC LIGHT TELEPHONE & TELEGRAPH SUPPLIES. WALLACE DIAMOND TRADE MARK THE ELECTRICAL SUPPLY CO. 109 LIBERTY ST. NEW YORK.

TOOPE'S PATENT Asbestos Lined Removable Covering, Made of Felt and Asbestos. For use on STEAM BOILERS and PIPES, Refrigerators, Meat Cars, Ice Houses, and HOT and COLD WATER PIPES. Easily applied by any one. Address CHALMERS-PENCE CO., 23 John St., New York.

ESTABLISHED 1841. JOHN HOLLAND, Manufacturer of GOLD PENS, Pen Holders, Pencil Cases, MacKinnon Stylographic and Elastic Fountain Pens. Over one million of our Gold Pens now in use, many of them more than twenty years old. If not sold by your stationer or jeweler, send for illustrated price list to 19 West 4th St., Cincinnati, O.

The Mines of the Carolinas Use Van Duzen's Patent Steam Jet Pump. Far superior to any other Jet Pump for practical service. Made of Brass; has no valves, no moving parts, no small openings, will pump Dirty, Sandy, Gritty Hot, or Cold Water. Will raise water to 50 feet vertically. Can be used with hose. Warranted reliable and satisfactory. Prices from \$7 up. Capacities 300 to 20,000 gal. per hour. Demand this pump and take no cheap substitute. Send for "Catalogue No. 49." VAN DUZEN & TIFT, Cincinnati, O.

EVAPORATING FRUIT. Treatise on improved methods SEND FREE Wonderful results. Tables of Yields, Prices, Profits, and General Statistics. Address AMERICAN MANUF'G CO., Waynesboro, Pa. American Fruit Drier.

KORTING UNIVERSAL INJECTOR

DOUBLE TUBE. FOR BOILER FEEDING. Operated by one handle. WILL LIFT HOT WATER. POSITIVE ACTION GUARANTEED UNDER ALL CONDITIONS. NO ADJUSTMENT FOR VARYING STEAM PRESSURE. WILL LIFT WATER 25 FEET. SEND FOR DESCRIPTIVE CIRCULAR. OFFICES AND WAREHOUSES: PHILADA., 12TH & THOMPSON STS. NEW YORK, 109 LIBERTY ST. BOSTON, 7 OLIVER ST. CHICAGO, 84 MARKET ST. AUGUSTA, GA., 1028 FENWICK ST. ST. LOUIS, MO., 709 MARKET ST. DENVER, CO., 438 BLAKE ST. SAN FRANCISCO, 2 CALIFORNIA ST. RICHMOND, VA., 1419 MAIN ST.

HARTFORD STEAM BOILER Inspection & Insurance COMPANY. W. B. FRANKLIN, V. Pres't. J. M. ALLEN, Pres't. J. B. PIERCE, Sec'y.

Shimer Cutter Heads 10,000 SOLD. To work Car Siding, Flooring, Ceiling and Ship Lap. To Mould Doors, Sash, and Blinds. Cope Heads to match. Shimer & Co., Milton, Pa. Pat. Jan. 26, 75. Exp. July 27, 86. Registered Oct. 19, 1878. July 18, 79.

WANTED. Correspondence with Engine Builders, Boiler Makers, and Supply Dealers in Steam Goods. We manufacture the cheapest Injectors and best Steam Jet Pumps in this country, and offer the most liberal terms ever named to live men. Drop postal for particulars to J. B. SHERRIFF, SON & CO., 68 Water St., Pittsburg, Pa.

PATENT COLD ROLLED SHAFING.

The fact that this shafting has 75 per cent. greater strength, a finer finish, and is truer to gauge, than any other in use renders it undoubtedly the most economical. We are also the sole manufacturers of the CELEBRATED COLLINS' PAT. COUPLING, and furnish Pulleys, Hangers, etc., of the most approved styles. Price list mailed on application to JONES & LAUGHLINS, Try Street, 2d and 3d Avenues, Pittsburg, Pa. Corner Lake and Canal Sts., Chicago, Ill. Stocks of this shafting in store and for sale by FULLER, DANA & FITZ, Boston, Mass. Geo. Place Machinery Agency, 121 Chambers St., N. Y.

F. Brown's Patent FRICTION CLUTCH. Send for Illustrated Catalogue and Discount Sheet to A. & F. BROWN, 43 Park Place, New York. SHAFTS PULLEYS HANGERS

Steel Castings

From 1/2 to 15,000 lb. weight, true to pattern, of unequalled strength, toughness, and durability. 20,000 Crank Shafts and 15,000 Gear Wheels of this steel now running prove its superiority over other Steel Castings. Send for circular and price list. CHESTER STEEL CASTINGS CO., 407 Library St., Philadelphia, Pa.

SCIENTIFIC AMERICAN

FOR 1883. The Most Popular Scientific Paper in the World. Only \$3.20 a Year, including postage. Weekly. 52 Numbers a Year.

This widely circulated and splendidly illustrated paper is published weekly. Every number contains sixteen pages of useful information, and a large number of original engravings of new inventions and discoveries, representing Engineering Works, Steam Machinery, New Inventions, Novelties in Mechanics, Manufactures, Chemistry, Electricity, Telegraphy, Photography, Architecture, Agriculture, Horticulture, Natural History, etc. All Classes of Readers find in the SCIENTIFIC AMERICAN a popular resume of the best scientific information of the day; and it is the aim of the publishers to present it in an attractive form, avoiding as much as possible abstruse terms. To every intelligent mind, this journal affords a constant supply of instructive reading. It is promotive of knowledge and progress in every community where it circulates. Terms of Subscription.—One copy of the SCIENTIFIC AMERICAN will be sent for one year—52 numbers—postage prepaid, to any subscriber in the United States or Canada, on receipt of three dollars and twenty cents by the publishers; six months, \$1.60; three months, \$1.00. One copy of the SCIENTIFIC AMERICAN and one copy of the SCIENTIFIC AMERICAN SUPPLEMENT will be sent for one year, postage prepaid, to any subscriber in the United States or Canada, on receipt of seven dollars by the publishers. The safest way to remit is by Postal Order, Draft, or Express. Money carefully placed inside of envelopes, securely sealed, and correctly addressed, seldom goes astray, but is at the sender's risk. Address all letters and make all orders, drafts, etc., payable to MUNN & CO., 261 Broadway, New York.

PRINTING INKS. THE "Scientific American" is printed with CHAS. T. BENEJOHNSON & CO.'S INK. Tenth and Lombard Sts. Phila., and 47 Rose St., opp. Duane St., N. Y.

Leffel Water Wheels,

With Important Improvements. 11,000 IN SUCCESSFUL OPERATION. FINE NEW PAMPHLET FOR 1883. Sent free to those interested. JAMES LEFFEL & C., Springfield, Ohio. 110 Liberty St., N. Y. City.

NUT TAPPING MACHINE. DURELL'S PATENT.

No. 1 Machine, 900 lb., 7 spindles. " 2 " 1,050 " 7 " " 3 " 600 " 9 " Capacity of 7 spindles, 8,000 per 10 hours. Acknowledged to be an indispensable tool. Manufactured by HOWARD BROS., Fredonia, N. Y.

MINERAL PROSPECTING MACHINERY

for prospecting and developing mines, operated by steam or horse power to any depth (or by man power in isolated places). Better than Diamond Drills. Portable, low priced, thoroughly tested and proved. Send 2c. stamp for catalogue. C. D. Pierce Drill Co., 29 Rose Street, New York.

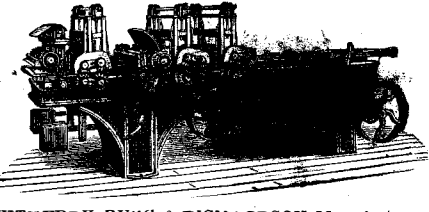

WITHERBY, RUGG & RICHARDSON, Manufacturers of Patent Wood Working Machinery of every description. Facilities unsurpassed. Shop formerly occupied by R. Ball & Co., Worcester, Mass. Send for Catalogue.

VERTICAL ENGINES THE BEST IN THE MARKET AT REASONABLE PRICES MANUFACTURED BY PHOENIX FOUNDRY & MACHINE CO. SYRACUSE N. Y.