

SCIENTIFIC AMERICAN

[Entered at the Post Office of New York, N. Y., as Second Class Matter.]

A WEEKLY JOURNAL OF PRACTICAL INFORMATION, ART, SCIENCE, MECHANICS, CHEMISTRY AND MANUFACTURES.

Vol. XLVII.—No. 16.
[NEW SERIES.]

NEW YORK, OCTOBER 14, 1882.

[\$3.20 per Annum.
[POSTAGE PREPAID.]

FIRELESS LOCOMOTIVES FOR TRAMWAYS.

BY G. LENTZ, DIRECTOR OF THE LOCOMOTIVE WORKS, HOHENZOLLERN.

The fireless locomotive, of which we give an outside elevation, is one of a type of which a considerable number are being built by the Locomotiv Fabrik Hohenzollern, for Java. They are constructed with inside frames and inside cylinders; the wheels are four in number and are coupled. The reversing gear is of the Joy type. The steam or hot-water reservoir rests on two cross-stays connecting the longitudinal frames of the engine; it is a plain cylinder with bulged ends and a dome. Steam is taken from the dome of the reservoir through a perforated copper pipe leading into a reducing valve, where the pressure is reduced to 100 pounds per square inch, and the steam is then conveyed through a pipe of large diameter which passes through the water space of the reservoir and through the bottom; where it divides, a branch leading to each valve box. A steam trap is formed at the termination of the large steam pipe, a smaller pipe leading some distance up into it, and very dry steam is thus obtained for the cylinders. This arrangement offers, no doubt, considerable advantage over the steam supply of ordinary small locomotives, where frequently a large percentage of water is carried over into the cylinders, particularly when the boilers are worked hard.

The steam reservoir of this tram engine is carefully protected, by means of sheet iron, layers of felt, and air space, from loss of heat by radiation, and it has been found by experience that the loss in pressure amounts to from $3\frac{1}{2}$ pounds per hour in summer to 7 pounds per hour in winter.

The arrangement for admitting high pressure steam into this boiler consists of a valve, fitted with a coupling for connecting a flexible hose, and fixed to the back end of the boiler, and a steam feed pipe enters the boiler and extends down to the bottom, where it enters a perforated pipe placed along the bottom of the boiler. When steam is admitted a considerable ebullition takes place, all the water

is evenly heated through, dead water cannot lodge anywhere, and the boiler is, therefore, not liable to much wear and tear, and will last many years, while the small tubular boilers of locomotives are difficult to clean and repair, often badly fired, and maintained, and while only lasting from five to eight years, cause heavy expenditures for repairs even during this time.

It is evident that, with a properly constructed plant of stationary boilers of first-class workmanship—none other would be advisable for such high pressure, and an injudicious attempt to save in this plant might lead to serious difficulties—steam can be produced in the most economical manner; hot feed, large grates, cheap fuel, and a reduced staff of attendants, all help to materially reduce the cost of steam. Returning now to the fireless tramway engines, we find that one engine driver is sufficient for each locomotive. Boiler repairs being all but avoided, a smaller number of standby locomotives are required, reducing not only the capital involved, but also cost for repairs, and requiring smaller repairing shops.

Great benefits result to the traveling public from the absence of fire in these locomotives; there are no flying sparks, ashes, cinders, and unpleasant products of combustion; the engine and carriages remain longer clean, and costs for cleaning and repairs alike are reduced. There is also a saving in labor and fuel due to the circumstance that the engines do not require to be lighted up in the morning; they are charged before being brought into the sheds at night, and although they lose from 30 pounds to 60 pounds pressure during night, they are ready for work at any moment's notice.

The hot water reservoirs of engines weighing $9\frac{1}{2}$ tons have been made to contain 462 gallons of water, which has been found amply sufficient. To construct an ordinary locomotive for the same work would require some 73 horse power, which could not well be obtained in less than 13 tons

weight, and this would necessitate heavier permanent way, and would require an extra amount of fuel and water to carry the additional dead weight.

A very important advantage in favor of fireless locomotives is the fact that the power stored in the hot water reservoir may be used as conditions require, and a uniform speed can be kept up on rising gradients as well as on level, a result not obtainable with ordinary locomotives.

Where the exhaust is used as chimney blast a slow speed causes, moreover, a slower combustion, and it is not a rare occurrence that locomotives come to a dead stop on steep gradients, an accident that cannot happen with fireless locomotives, since they always possess a very large store of power.

An excellent field for the application of fireless engines is open in small river steamers which have only to run short distances. In place of a boiler, these steamers carry a water reservoir, and they are charged with steam at the landing pier through well protected piping. On small steamers, boilers are frequently worked at great disadvantage, they are indifferently attended to, difficult to clean, and frequently worked when in a dangerous condition. It will, moreover, be acknowledged that small marine boilers are difficult to manage, they have but little water space, steam rises and water falls rapidly, and it can only be surprising that explosions do not happen more frequently.

For these reasons stated above the fireless arrangement appears admirably suited for small steamers. In laying out the stationary boiler plant for supplying the necessary steam, economically constructed boilers with large water contents, steam room, and large steam surface should be provided, evaporating about 3.5 pounds of water per square foot of heating surface per hour. In calculating the dimensions of the stationary plant required in connection with these locomotives, it may be assumed that about one-ninth of the contents of the reservoirs has to be resupplied at each charge,

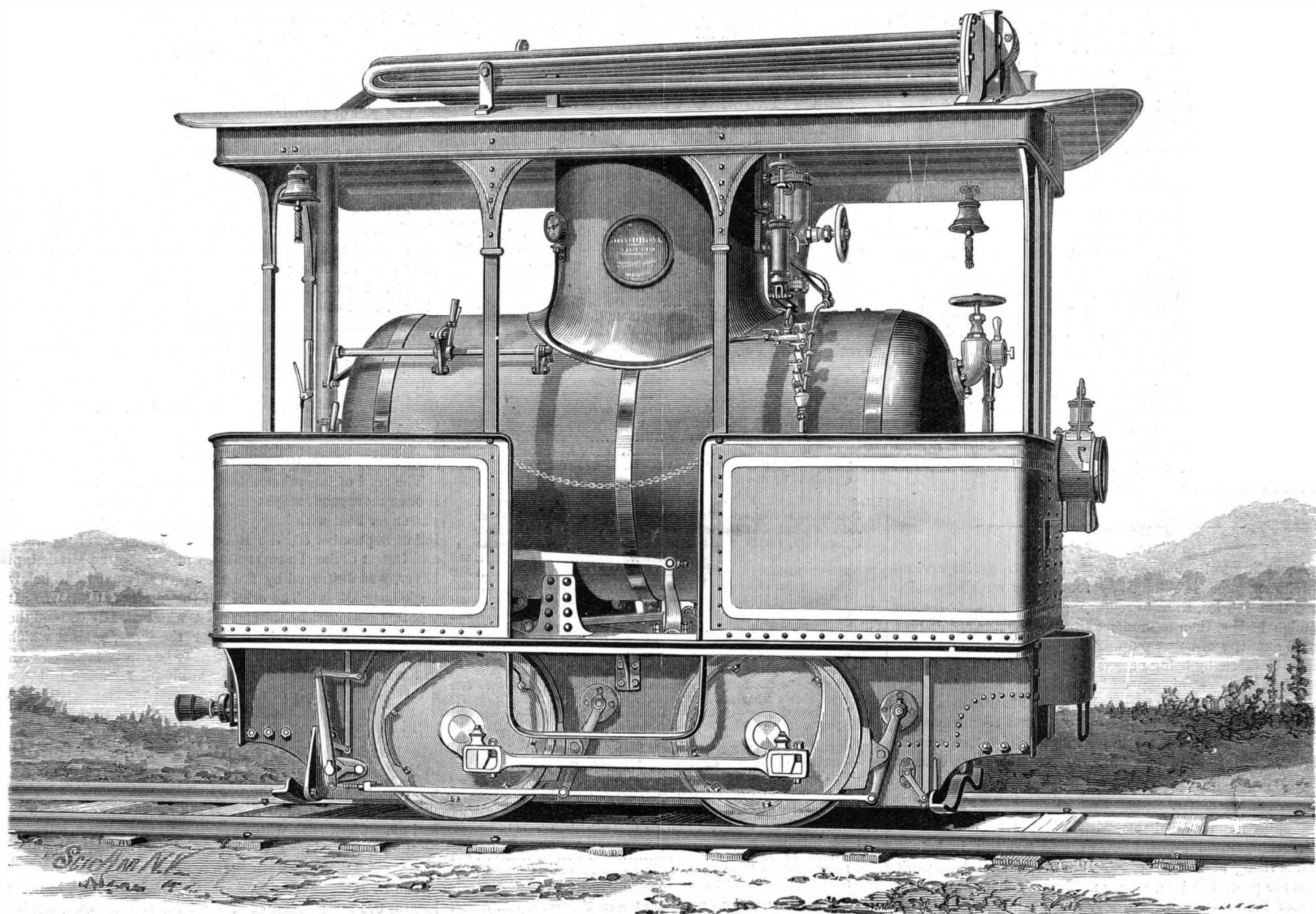

FIRELESS TRAMWAY LOCOMOTIVE FOR JAVA.—CONSTRUCTED AT THE HOHENZOLLERN LOCOMOTIVE WORKS, DUSSELDORF.

if, therefore, the engine we calculated of 9 1/2 tons total weight carries 4,540 pounds of water it would require 550 pounds of steam at the commencement of each journey.

This system of fireless engines was first introduced by Dr. Lamm, of New Orleans, in 1872, and the first engines were started on this principle in 1874.

The Hohenzollern Locomotive Works, at Düsseldorf, are at present building a large number of fireless locomotives and plant for Java, and an interesting series of comparative trials is now being carried out on an experimental line near to these works between fireless and ordinary locomotives.

The fireless locomotives are being fed from one of the stationary boilers built for Java, and run the whole distance for which they are afterwards intended, drawing behind them the proper train weight.

Aconite in Dysentery.

Dr. Owen reports the results of one hundred and fifty-one cases of acute dysentery treated with aconite. He was induced to look about for another treatment than the conventional one with ipecac, on account of the nausea which often attends the latter, and which often drives hospital patients, especially, to rebel against a repetition of the dose.

Quick Work at an English Colliery.

A note was made recently of an example of rapid raising of coal at an American colliery. The following, which is regarded in England as a remarkable instance of expeditious work, will serve for comparison: Pit No. 3, Newlands, near Baillieston, Braehead Collieries, is 120 fathoms deep.

Waterproof Paper.

According to the Journ. Soc. of Arts, a strong, impervious parchment-paper is obtained by thoroughly washing woolen or cotton fabrics, so as to remove gum, starch, and other foreign bodies, then to immerse them in a bath containing a small quantity of paper pulp.

Washington Monument.

Washington monument now exceeds 300 feet in height, and is rising at the rate of about a foot a day. The workmen are protected by a strong netting which surrounds the top of the monument.

Scientific American.

ESTABLISHED 1845.

MUNN & CO., Editors and Proprietors.

PUBLISHED WEEKLY AT

No. 261 BROADWAY, NEW YORK.

O. D. MUNN.

A. E. BEACH.

TERMS FOR THE SCIENTIFIC AMERICAN.

One copy, one year postage included. \$3 20
One copy, six months postage included. 1 60

Clubs.—One extra copy of THE SCIENTIFIC AMERICAN will be supplied gratis for every club of five subscribers, \$3.20 each; additional copies at same proportionate rate. Postage prepaid.

MUNN & CO., 261 Broadway, corner of Warren street, New York.

The Scientific American Supplement

is a distinct paper from THE SCIENTIFIC AMERICAN. THE SUPPLEMENT is issued weekly. Every number contains 16 octavo pages, uniform in size with THE SCIENTIFIC AMERICAN.

Combined Rates.—THE SCIENTIFIC AMERICAN and SUPPLEMENT will be sent for one year postage free, on receipt of seven dollars.

Scientific American Export Edition.

THE SCIENTIFIC AMERICAN Export Edition is a large and splendid periodical, issued once a month. Each number contains about one hundred large quarto pages, profusely illustrated.

NEW YORK, SATURDAY, OCTOBER 14, 1882.

Contents.

(Illustrated articles are marked with an asterisk.)

Table listing various articles such as 'Aconite in dysentery', 'Infants, an incubator for', 'Inventions, agricultural', etc., with corresponding page numbers.

TABLE OF CONTENTS OF THE SCIENTIFIC AMERICAN SUPPLEMENT, No. 854, For the Week ending October 14, 1882.

Table listing contents of the supplement, including sections like 'I. ENGINEERING AND MECHANICS', 'II. TECHNOLOGY AND CHEMISTRY', 'III. ELECTRICITY, ETC.', etc.

THE JEANNETTE EXPEDITION.—LIEUTENANT DANENHOWER'S LECTURE.

Lieutenant J. W. Danenhower, of the unfortunate exploring expedition in the Jeannette, has prepared a course of lectures on the experiences and results of the expedition, illustrated by large and carefully prepared charts of the regions traversed.

The dangers of the expedition began when Wrangell Land was sighted, September 9, 1879, and the Jeannette entered the ice fields. The sun disappeared September 9, and soon after the vessel was caught in the ice field, which did not relax its grasp until the following June.

The absence of icebergs in the part of the Arctic Sea traversed by the Jeannette was specially noticeable. The ice which covered the sea in all directions was true polar ice, the frozen salt water of the sea, which grows from eight to ten feet in thickness in a single winter.

The sinking of the Jeannette was vividly described. The retreat of boats to the Siberian shore began on the anniversary of the Battle of Bunker Hill, June 17. After Bennett Island was sighted the party were fifteen days going twenty-five miles to reach it.

ACCIDENT WITH ELECTRIC LIGHT WIRES.

The first fatal accident with electric light wires in this city occurred October 4, the victim being an experienced line man in the employ of the Brush Electric Light Company. He was engaged in splicing a "live" wire to increase its length so that it could be transferred to another and higher pole.

FIREPROOF UPPER WORKS FOR STEAMERS.

The need of incombustible upper works for river steamers is once more made emphatic by the burning of a magnificent passenger boat with heavy loss of life. Early in the morning of September 30, the Robert E. Lee, one of the finest and fastest of the large steamers plying on the Mississippi River, was destroyed by fire about twenty-five miles below Vicksburg, Miss.

The R. E. Lee was a side wheeler, of 1,479 tons burden; length, 315 feet; beam, 48 feet; with storage capacity for 9,000 bales of cotton.

stroke. She had been newly refitted and painted, the fatal trip being the first of the season. Particularly noticeable was her apparatus for fire protection, which proved entirely useless, so rapid was the progress of the flames.

The inspection records show that she had on board five independent fire pumps, two worked by steam, the other three by hand. In connection with these were 700 feet of hose, with ten openings for attachment at various parts of the boat. These pumps were situated forward, aft, and amidships. In addition to this she had on the hurricane deck or roof 50 buckets, eight barrels, and two large tanks, all filled with water. Two metal and two wooden lifeboats were in their cradles upon the roof and one working boat at the stern. One hundred and sixty life preservers had just been put in perfect order, and eighty-five floats were hung about below, in places easy of access. Her crew list numbered 44, all told, officers and men, headed by a captain, engineer, and steward of the largest experience.

The moral of this disaster would seem to be that of so many other fatal steamer fires; safety is to be sought not in means for putting out fire, but in so constructing the upper works that they will not burn. As at present constructed, of light lumber saturated with oil, our "magnificent" steamboats for river, lake, and Sound service are simply gigantic piles of combustibles in the best shape for rapid burning. Iron hulls are a step in the right direction, but a very short step. For the security of passengers against fire the upper works also must be made incombustible.

THE GREAT COMET OF 1882.

On the 18th of September, a comet of extraordinary brilliancy suddenly flashed from the sky to the amazement and delight of the few fortunate observers whose gaze chanced to be directed toward the heavens on the eventful day. The comet was close to the sun, 3° west and a little south when first visible. The near proximity of his overpowering light had no power to prevent it from being readily seen by observers possessed of ordinary visual powers. It was a superb object in the full daylight, when the stars were hidden in the star depths, developing a well defined nucleus, and a tail a minute long, and giving proof of its wondrous proportions by daring to assert itself in the near presence of the powerful king of day.

Lord Crawford telegraphed its discovery by European observers to the Harvard University Observatory, and, almost simultaneously, the news came that Mr. Miller, of Leon, Kansas, had seen the celestial stranger. Other observers were equally fortunate. There was intense excitement in astronomical circles. The men of science went eagerly to work to find out where the erratic visitor came from, whither it was bound, when it would come back again, and if it were a newcomer or an old friend returning to take a peep at the sun and his family of worlds. Meantime, the comet traveled on in its resistless course, a million miles a day, little heeding the commotion it had caused among the dwellers on this small planet. Daily the distance increased between it and the sun, daily it grew more dim to mortal view, and almost daily in this vicinity was its beaming face hidden by the clouds born of the protracted equinoctial storm. It has now had its day in our view and has passed on where the telescopes in southern latitudes may dimly discern its retreating steps.

The men of science who make cometic astronomy a specialty have exhausted their resources in attempting to learn its history. They have followed its every footstep with scientific scrutiny and mathematical precision, and, as is often the case, have reached results which are diametrically opposed to each other. They agree, however, on two points, that the comet is receding from the sun and also from the earth.

The startling theory advanced by Professor Boss, of the Dudley Observatory, Albany, has excited much interest. In his view, the comet discovered on the 10th of September by Cruis, of Rio Janeiro, is identical with the new comet, and was then near perihelion, which it passed on the 17th. The professor believes that in this comet we behold a return of the famous comets of 1843 and 1880. He accounts for the present short period by the theory that at the two previous returns, it passed so near the sun as to graze the solar atmosphere, thus retarding its flight and shortening its period. According to his supposition, the next period will be still shorter, and we may expect the comet's return in 1884, if not sooner. It will thus keep on, drawing nearer and nearer to the sun until, meeting with some obstacle, it plunges headlong into his incandescent mass and is seen no more forever. This fine theory has the essential drawback that it diminishes a cometic period of thirty-seven years into one of less than three years. It will not be very generally accepted until the year 1884 rolls round and shows the same bright comet in full daylight, or until proof of its actual plunge into the sun brings confirmation strong to support the hypothesis.

Professor Chandler, of the Harvard University Observatory, an authority also in matters cometic, takes a different view of our gossamer-tailed visitor. He does not think that the new comet is identical with that of 1880, or that it will return in 1884, or that it will fall into the sun. The Cambridge astronomer believes that the new comet travels in a track similar to the one of 1880, and that the superb visitor to southern climes during that year is far on its way through unknown depths of space, not to return during the present century. In his view, the present comet is entirely independent of every other member of the cometic family, simply

taking the liberty of traveling behind the great comet of 1880 in nearly the same track, and without herald or harbinger, making its first appearance in full daylight as the great comet of 1882.

Professor Chandler gives an approximate computation of the elements of the new comet at Harvard Observatory, on the 22d of September, at 1 o'clock in the morning, Cambridge time:

Time of perihelion passage.....	1882, Aug. 30, 5
Longitude of perihelion.....	271°
Longitude of the node.....	173°
Inclination of orbit.....	17°
Perihelion distance.....	27,000,000 miles.

Commander Sampson, Assistant Superintendent of the Naval Observatory, Washington, sends to the astronomers of Europe, this computation of the elements of the new comet as embodying the conclusions of the naval astronomers—24th of September, Washington mean time:

Time of perihelion passage.....	Sept. 17, noon.
Longitude of perihelion.....	57° 23' 8"
Longitude of node.....	346° 26' 41"
Inclination of orbit.....	142° 11' 40"
Perihelion distance.....	.0086
Closely resembling comet of 1880.	

Lord Crawford sends to the astronomers of America, through the Harvard Observatory, the following computation of the elements of the new comet—25th September, Greenwich mean time:

Time of perihelion passage.....	Sept. 17, 0h. 37m.
Longitude of perihelion.....	43° 7' 58"
Longitude of node.....	342° 39' 34"
Inclination of orbit.....	140° 16' 46"
Perihelion distance.....	.008279

What can ordinary observers do when doctors disagree? A wise philosophy teaches that the work of the astronomers of the present generation is to observe and wait. It is only observation piled upon observation that will solve the simplest problems that now vex the minds of the students of astronomy. Nothing is more uncertain and unsatisfactory than the attempt to unravel the history of these erratic members of the material universe that suddenly dart upon our vision and as suddenly disappear from view. It is none the less certain that they have a mission to fulfill in the grand economy of the universe. One of these days, some one will find out what this mission is, and the observations made on every comet that sweeps the skies will help to bring about this much desired result.

THE GREAT COMET IN THE EAST.

Those who had the good fortune to see the great comet on the mornings of Sept. 30 and Oct. 1, when it was brightest, enjoyed a spectacle which may not be paralleled in a century. The head of the comet then appeared as bright as Sirius, and its long brilliant tail streamed across the eastern sky in a style fairly answering one's ideal of what a comet ought to be. Notwithstanding the bright moonlight and the growing light of dawn, the comet as a whole rivaled in beauty and magnitude the great comet of 1858 (Donati's) seen under much more favorable conditions.

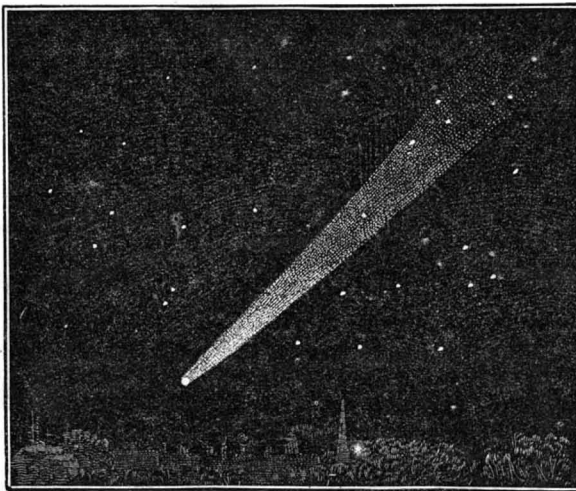

COMET AS SEEN BY THE EYE.

The cut herewith represents, as well as an engraving can, the general aspect of the comet as seen with the unaided eye, on Monday, Oct. 2. At the earlier dates mentioned, the lower line of the tail was perfectly straight. In receding from the sun the brightness of the nucleus fell off rapidly, so that by the middle of the week it was comparable with that of the second magnitude star Alpher, near the end of the comet's tail.

On the morning of October 5, Mr. E. E. Barnard, of Nashville, Tenn., saw what led him to believe that the nucleus of the comet had separated into three unequal fragments, the dividing spaces being not less than 2,000 miles wide. The entire nucleus appeared to be an elongated bolt, about 24,000 miles long, with a breadth of 3,000 miles. The largest fragment was estimated to have a length of 15,000 miles.

Observations made the same morning by Professor Wilson at the Cincinnati Observatory agreed substantially with those of Mr. Barnard. At the Naval Observatory in Washington the light of the nucleus appeared to be unequal in parts, but so far as observed the light was continuous, from which it was inferred that there had been no split. The nucleus was described by Professor Frisby as longer than on previous mornings, and slightly more spread out, with a small central condensation about three quarters of its length from

the end nearest the tail. The tail was about 17° or 18° long. The change in the nucleus does not affect the appearance of the comet to the naked eye.

STORM, FLOOD, AND FROST SIGNALS BY TELEGRAPH AND CANNON.

A short time since a correspondent suggested the employment of cannon signals to supplement the telegraph in giving warning of storms, floods, etc., in regions sparsely settled. The suggestion was not a novel one, but the time seemed favorable for reiterating it. We have since learned that in certain tobacco growing regions the planters have arranged to supplement the reports of threatened frosts sent out by the signal bureau, by means of cannon signals to warn those at a distance from telegraph stations. The plan is likely to prove beneficial and worthy of wide extension.

In considering the value of a system of gun signals, it must be borne in mind that it proposes to fill a wide and important gap in the existing system of weather service. In the first place, the severer and more destructive storms are apt to be of limited range; besides they are largely due to local conditions which make their prediction certainly from a distance quite impossible. And when they are foreseen and preannounced, the information is sent to towns where the telegraphic stations are, while the people to be chiefly benefited are scattered throughout the adjacent country. What is needed is a means of reaching the people as a whole instantly and generally, at their homes and in their fields; which can be done most effectually by sound signals.

In cases of floods, tornadoes, or other sources of sudden public peril, sound signals seem to be by far the most rapid means of conveying a general warning.

In this connection it is due to Mr. Augustus Watson, of Washington, D. C., to say that if not the first proposer of this method of signaling, he has certainly been the most persistent in urging it. He began to publish articles on the subject as long ago as 1867; and in 1868, two years before the establishment of the weather bureau, he proposed it to Congress. Since that time Mr. Watson has made many endeavors to have the plan tried by the Signal Service, but without success.

It is a question whether the Signal Service would be able, if it were willing, to undertake so vast a service as Mr. Watson's plan, adequately carried out, would create. The tobacco farmers seem to be pursuing the more practical course. If the plan works well in their case, it will be taken up by other communities for other purposes. The minute and special distribution and application of meteorological information for local benefit will probably have to be thus undertaken everywhere by the people themselves. The cost of local experiments will not be great, and the system, if found useful, will naturally increase in scope and efficiency until the whole country is covered with its ramifications.

It is possible that something cheaper and more readily handled than cannon might be devised for signaling by sound, a species of gigantic fire cracker, for example, or cartridges of gun cotton, or the like—should the system prove to be of general utility.

TARDILY RECOGNIZED GENIUS.

It is commonly said that genius always finds an opportunity for its own demonstration. This may be true; but it does not always follow that adverse circumstances may not prevent men of genius from doing the work they see ought to be done and which they are personally capable of doing.

A remarkable instance of genius unemployed is casually mentioned in the recent British Association address of the eminent civil engineer, Mr. John Fowler, president of the Section of Mechanical Science. Speaking of great achievements in tunnel engineering, Mr. Fowler mentions his own project for tunneling the silty bed of the Humber, a distance of one and a half miles, the bill for the authorization of which was passed by the House of Commons, but rejected by the Lords.

His plan he supposed to be entirely original until a few months ago, when, turning the leaves of an old periodical, he discovered that it had been substantially anticipated by a working smith by the name of Johnstone, who proposed it in 1823 for the Thames Tunnel, in lieu of the plan adopted by Brunel. Of this working smith's plan, Mr. Fowler says, after describing it:

"There is not a flaw in the design from beginning to end, as modern experience in the sinking of numerous bridge piers on precisely the same plan has amply demonstrated. It is beyond all doubt that if the design of this working smith had been adopted in lieu of that tendered by Brunel the Thames Tunnel would have been completed in a couple of years, instead of eighteen years, and at a cost of about £300 per yard instead of £1,500.

"If another tunnel be constructed under the Thames, which is far from improbable, as the requirements of below-bridge traffic necessitate some such means of communication, I venture to predict it will be built in accordance with the plan suggested fifty-nine years ago by the working smith, and not on that of Brunel's Thames Tunnel, or of any other tunnel yet carried out."

The Basic Iron and Steel Process.

We learn that an interference has just been declared by the Patent Office between Jacob Reese and James Henderson, to determine the question of priority of invention, in respect to the broad claim of dephosphorization of iron after decarbonization by use of basic reagents.

IMPROVED ORE SEPARATOR.

We give sectional and perspective views of a new ore separator or amalgamator, which is remarkable for the originality of its design, the novelty of the principle on which it operates, and the thoroughness and rapidity with which it does its work. It weighs only seven hundred pounds, but is capable of operating upon thirty tons of sand or crushed ore in ten hours. It requires but four horse power to drive six of them, and they occupy a floor space of only 4 x 4 feet each.

The machine operates by centrifugal force, the two principal moving parts revolving in opposite directions. By reference to the sectional view, it will be seen that the machine has two pulleys for receiving the driving belts, one pulley being placed on a vertical shaft revolving in a step in the supporting frame, and carrying at its upper end two parallel slightly coned disks or plates. The other pulley is placed on a sleeve on the vertical shaft, the sleeve carrying near its upper end four radial hollow arms, to the extremities of which is secured an annular pan. This pan incloses the coned disks carried by the vertical shaft, and is flared outward at the top and provided with an inwardly projecting rim for retaining the mercury used in the process of amalgamation.

To insure a uniform distribution of mercury in the annular pan, and to effect a perfect retention of the gold particles, the pan is lined with copper which is amalgamated.

The upper of the two coned disks has a central opening into which the ore is dropped from the hopper above. The hollow arms contain mercury, and when they are revolved together with the annular pan, the mercury is carried outward through openings in the ends of the arms into the pan, where it rises, forming a circular wall of mercury completely surrounding the coned disks but not touching their peripheries. The coned disks, receiving the sand from the hopper and revolving in a direction opposite to that of the pan, hurl the sand with considerable force against the wall of mercury. The gold being heavier than the mercury is carried outward by centrifugal force into contact with the amalgamated copper, where it remains until removed at the end of the operation.

The sand does not penetrate the mercury, and is driven off by air jets, of which there are several arranged at intervals around the top of the machine, and communicating with a circular pipe receiving a supply of air from a blower.

Below the hollow arms, and secured to the same sleeve, there is a coned refuse disk on to which the sand falls after being blown from the surface of the mercury. This disk throws the sand outside of the machine frame by centrifugal force. The revolving parts of the machine turn seventy-six times a minute.

It requires 200 lb. of mercury to charge the machine; but none of it is lost, the machine being very economical in all respects.

In various public experiments made by the inventor, one half ounce of gold dust was mixed with one half ton of sand and treated with this machine. In each case the gold was recovered without appreciable loss. These machines are made by Colwell Bros., 27th street and 11th avenue, New York. One of them is now on exhibition at the Permanent Exposition of the Inventors' Institute, Cooper Union, New York, where Mr. H. E. Henwood, the inventor and patentee, may be addressed.

SARSAPARILLA GATHERING.

—The Province of Amazonas, Brazil, exported, last year, 199 tons of sarsaparilla. The zarza vine grows in the swamps, in soil that in Canada is known as "black muck," and the collectors often spend weeks in these marshy pools. The roots are traced and raised with a sharp stick, but the vine is not disturbed, the roots being cut off near the stock, which is covered up with a little earth, so that fresh roots may grow, and, in time, a fresh harvest be gathered.

Decoration of Glass and Porcelain.

Three processes connected with the ornamentation of glass, porcelain, and earthenware, were lately brought before the Société d'Encouragement, Paris. M. Cacaault, of Colombes, prints, on the fine and hard earthenware of Creil, photographic impressions, which are fixed at a single burning. M. Lacroix, Paris, has produced pencils like those of plumbago, but consisting of various vitrifiable colors. A design executed with them, on glass, having the surface slightly dulled, stands the fire, and becomes fixed, like a painting on glass. A similar process, tried on porcelain a few years ago, is said not to have been successful. M. Lutz-Knechtle, a Swiss, decorated glass, cold, by his composition, made of a solution of silicate of soda or potassium,

Development of Steam Navigation on the Lakes.

Mr. T. Purdy, special agent in charge of the statistics of navigation for the Tenth Census, has made public some interesting facts relative to the development of steam navigation on the northern lakes. The information was obtained mainly from the records in the office of the Register of the Treasury.

The first steamer on the American side was the Ontario, built at Sacket's Harbor, in 1816. The Frontenac was launched about the same time on the Canadian shore.

The Ontario measured 231 tons, had beam engines, 34-inch cylinders of 4 feet stroke, and ran till 1832. The next steamers were the Sapha, of 49 tons, built at Sacket's Harbor in 1818; and the Walk-in-Water, built at Black Rock in the same year. The latter measured 442 tons, had lower pressure engines, and made her first trip to Detroit in August, 1818. Afterward she traded as far as Mackinaw, and was finally wrecked, November 1, 1820, at Buffalo.

At this time there were as many as seventy steamers plying on the Western rivers, and forty-six had been built on the Atlantic coast. The tardy adoption of steam on the lakes is attributed to the lack of good harbors.

In 1822 the Superior, measuring 346 tons, was built at Buffalo, and in the following year the Martha Ogden, of 48 tons, was built at Black Rock. The Pioneer, of 124 tons, came out in 1825, at Buffalo, followed in 1826 by the Niagara, 156 tons; the Henry Clay, of 301 tons; and the Enterprise, at Cleveland, measuring 219 tons. This, it appears, was the first steamer

built at Cleveland. The William Penn, of 214 tons, came out the same year at Erie. One small steamer of 93 tons completes the list for this decade, making eight steamers, measuring 1,505.13 tons.

Up to 1830 there had been built on the lakes, according to these records, eleven steamers, measuring 2,128 tons, as against 293 steamers, measuring 50,806 tons, on the Western rivers, and 196, measuring 85,678 tons, on the Atlantic and Gulf coast.

In the first year of the next decade no steamers were built on the lakes. In 1832 there were three built at Erie and one at Cleveland. In 1833 one at Oswegatchie, four at Detroit, one at Sandusky, and one at Sacket's Harbor. In 1834 one at Oswego, one at Erie, five at Detroit, two at Sandusky, and two at Cleveland. In 1836 one at Oswego and one at Detroit. In 1837 one at Detroit, one at Miami (Toledo), one at Sandusky, and three at Cleveland. In 1838 five at Detroit, two at Miami.

In 1835 the steamship inspection service reported, for the northern lakes, 128 licensed steamers, measuring 68,098 tons; and 115 unlicensed, measuring 21,252; from which it would appear that there were then in use on the lakes many American steamers built at other points than those above named.

No other authentic statement of the steam tonnage of the lakes appears until 1870, when the Treasury records showed 642 steamers, measuring 142,937 tons. In 1880, according to the records of the Census Office, there were 973, which measured 224,857 tons.

Repairing an Injured Eye.

At the Jefferson College Hospital, Philadelphia, September 29, Dr. H. L. Little transplanted a portion of the conjunctiva of a rabbit's eye to that of a young Irishman, whose eye had been badly burned by sulphuric acid. Dr. Little removed the eye-

lid from its firm adhesion to the ball, and made it ready for the new piece of membrane, which Dr. L. W. Fox, assisted by Dr. Hewson, had carefully dissected from the left eye of the unconscious rabbit, and the part was rapidly transferred to the under surface of the man's eyelid and neatly stitched to its place. Another operation will be performed that will, it is thought, restore sight to the injured eye.

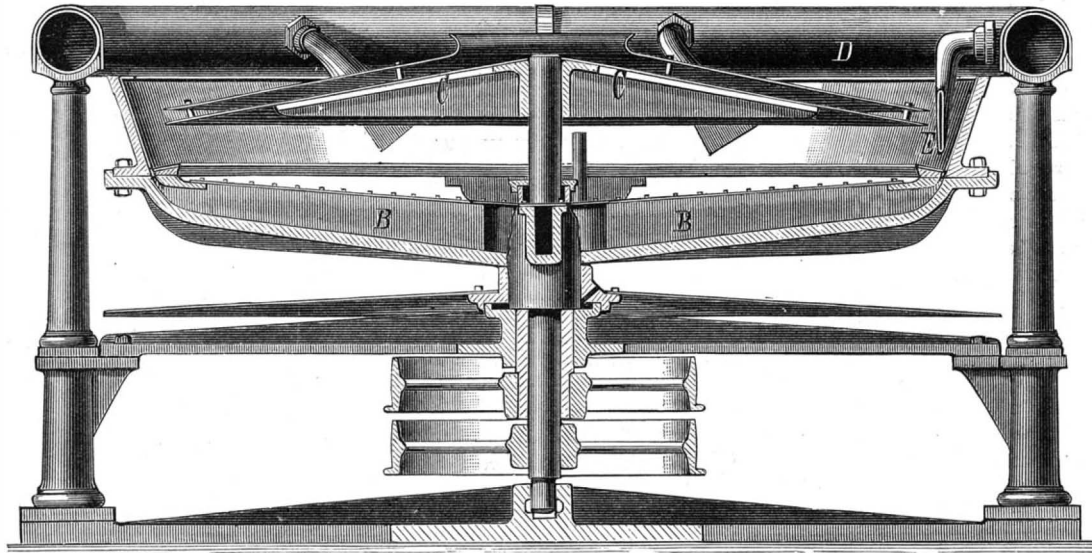
**HENWOOD'S ORE SEPARATOR—VERTICAL SECTION.**

with the addition of zinc-white or ultramarine. The colors are applied by means of a stamp or roller, dry quickly, and stand washing.

A Plague of Flies.

On Sunday, September 3, between 1 and 2 P.M., an extraordinary cloud of winged insects passed over Woolwich, England, and the district. The wind was blowing lightly from the E. N. E., following westerly and southwesterly breezes of several days' duration, and the weather was warm and bright. First came a very unusual number of the larger kind of flies, and sweeping after them, apparently across the Thames from the Essex meadows, came in a dense host of small drab-colored and light-winged insects,

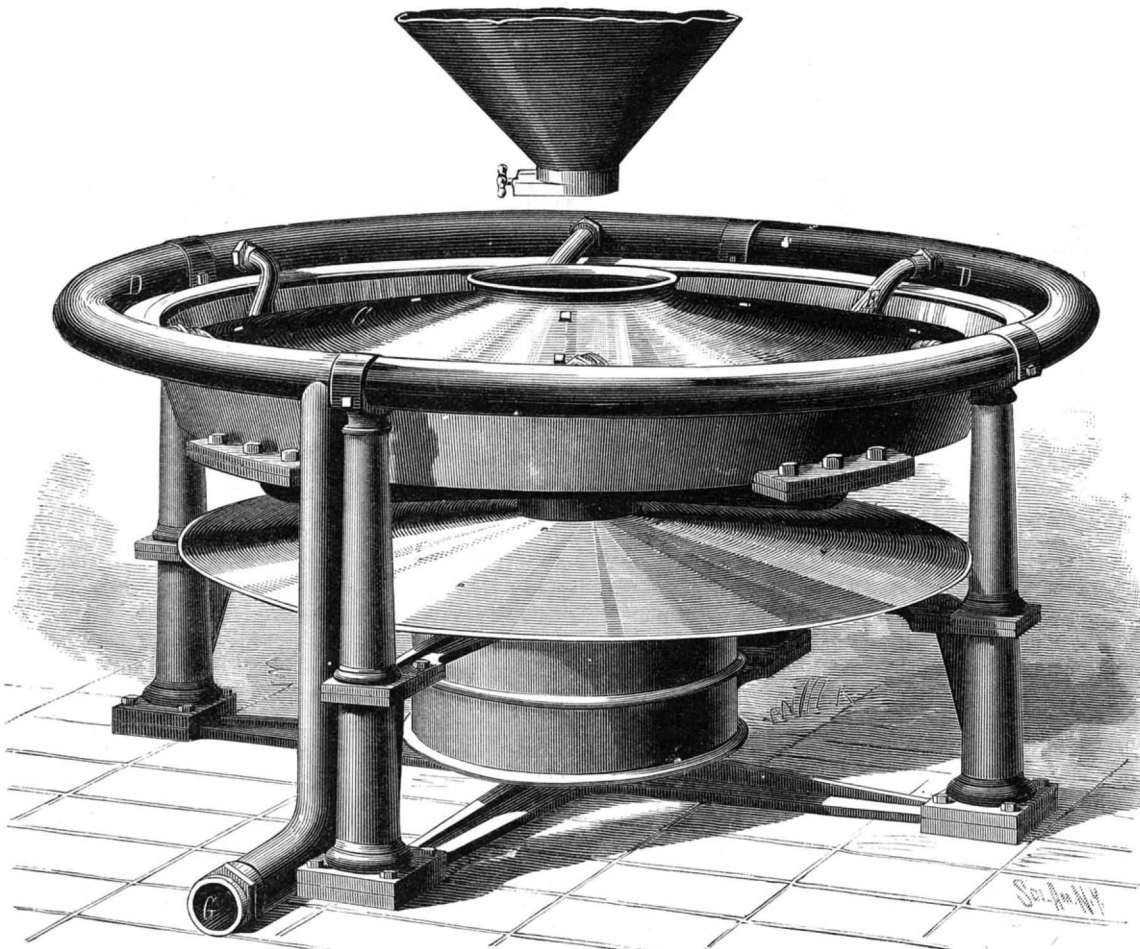
**HENWOOD'S ORE SEPARATOR.**

which filled the air like a misty rain, and smothered the clothing of all who were abroad. The cloud of floating animalcules was at least two miles wide, and it was about half-an-hour in passing away to the southwest.

On page 179 of current volume, in describing a new cotton seed huller, we find an error in the address of the inventor. It should be Hugh S. Walsh, Argenta, Arkansas.

The Circulation of Underground Waters.

In the course of the proceedings in the Geological Section of the British Association, at the recent Southampton meeting, Mr. C. E. De Rance read the report of the committee appointed for the purpose of investigating "The Circulation of the Underground Waters in the Permeable Formations of England, and the Quality and Quantity of the Water supplied to Various Towns and Districts from these Formations." There was added to the report an appendix, written by Mr. Edward Wethered, on the density and porosity of rocks in relation to the water supply.

The author of the appendix commenced by averring that a knowledge of the porosity of rocks was important as regards the water supply, the suitability of stone for building purposes, and in accounting for some of the lithological changes often observed in the earth's strata. Though the matter had not escaped investigation, the vast volume of water stored in the rocks had not been fully realized. The density of the old red sandstone was 2.61, the volume of water absorbed by a cubic foot being more than 0.707 gallon; and by a square mile, 3 feet thick, 59,000,000 gallons. The conglomerate beds of the same formation were still more absorbent; being capable of taking in 0.805 gallon per cubic foot, or 67,000,000 gallons per square mile, 3 feet thick. The millstone grit, which lay at the base of the coal measures, varied much in different localities; that found in the Forest of Dean being the most porous, absorbing 66,000,000 gallons per square mile, 3 feet thick. Some of the coal measure grits also stored large volumes of water. The Penant rock, about 900 feet thick, in the Bristol coalfield, and extensively developed in Somersetshire, as also around Swansea, was capable of absorbing 12,000,000 gallons per square mile, 3 feet thick; and specimens of magnesian limestone taken from the neighborhood of Bristol, showed a porosity of 86,000,000 gallons. The carboniferous limestone, however, was quite the reverse, and only absorbed 3,500,000 gallons. Oolites held vast stores of water, and the rock was much used for building.

Mr. Wethered then referred to the relation of specific gravity to porosity; and proceeded to say that shallow well-water had been classed by the Rivers Pollution Commissioners as dangerous, and the deep as wholesome, and there must, therefore, be a purifying process going on during the percolation into the earth. From an analysis of rocks, it was clear that nothing in the chemical composition of the rock could purify the water; and in order to get rid of organic contamination there must be oxidation, and they must, therefore, look to another source for the oxidizing agent. This, he thought, existed in the air absorbed by the water, and in the air contained in the interstices of the rock.

Poisonous Colors.

The German Government has just laid before the Reichstag the following decree, bearing date May 1, 1882, concerning the prohibition of poisonous colors for the coloring of certain alimentary substances and articles of food:

1. The use of poisonous colors for the manufacture of food-products or articles of food intended for sale is prohibited. Those which contain the following materials or compositions are considered as poisonous colors within the meaning of this enactment: antimony (oxide of antimony), arsenic, barium (except sulphate of baryta), lead, chromium (except pure chromic oxide), cadmium, copper, mercury (excepting cinnabar), zinc, tin, gamboge, picric acid. 2. The preserving and packing of food stuffs or food products intended for sale in wrappers colored with the above-cited poisonous colors, or in barrels in which the poisonous color is so employed that the poisonous coloring matter can pass into the contents of the barrel, is prohibited. 3. The employment of the poisonous colors enumerated in Art. 1 is prohibited for the manufacture of playthings, with the exception of varnish and oil paints made of zinc-white and chrome-yellow (chromate of lead). 4. The use of colors prepared with arsenic for the manufacture of paper hangings, as well as that of pigments containing copper prepared with arsenic, and of matters containing similar colors for the manufacture of materials of dress, is prohibited. 5. The putting on sale, and the sale, wholesale or retail, of food stuffs and food products preserved or packed contrary to the regulations of Articles 1 and 2, as well as playthings, paper hangings, and dress materials manufactured in contravention of the directions in Articles 3 and 4, are prohibited. 6. This law will come into operation on April 1, 1883.—*Br. Med. Journ.*

An Incubator for Infants.

M. Tarnier, the surgeon of the Maternity Hospital in Paris, struck by the great mortality among infants prematurely born, and those which are very sickly after birth, has conceived the ingenious idea of constructing a box which is almost exactly similar to the incubators used for poultry. This box is divided into two compartments—the lower one being used as a reservoir for hot water, while the infant is placed in the upper one, which is well stuffed at the sides and fitted with a sliding glass cover. The temperature is maintained at 86° Fahr., and M. Tarnier has found that by keeping infants in the incubator for a period varying from two days to six weeks, their vitality is enormously improved. He has made experiments upon five six-months children, six seven-months, and thirteen eight-months children, and he has only lost two of them, whereas, according to his statement, three-fourths of them would have died but for this adventitious aid to vitality.—*Lancet.*

STEAM HAMMERS.

The steam hammer, itself a modern novelty, has become a general adjunct to mechanical labor in all operations of hammering requiring graduated weight, quietly repeated blows, and precision. They are now to be found in smiths' shops as well as in large forges and rolling mills, but with smiths' shops the cost and complicated arrangements of those that have been constructed, requiring special skill for management, have interfered with their wider use.

Mr. David Bell, the eminent builder of iron ships and yachts, engines and boilers, of Buffalo, N. Y., noting the cause of this restriction in the use of the steam hammer, where it would be serviceable in finishing by machinery and in vise work, etc., applied himself to construct one that

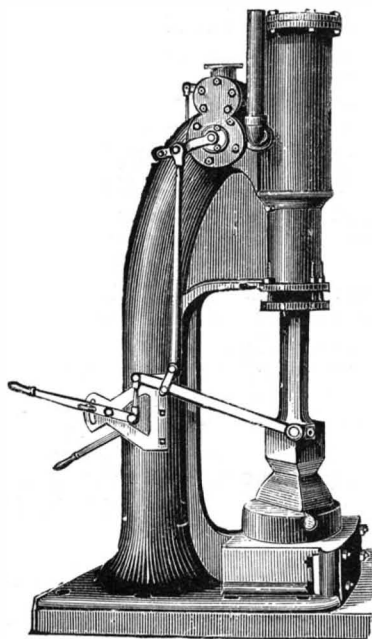

BELL'S STEAM HAMMER.

would meet every requirement of the smith's shop, aiming especially at simplicity of construction, combined with strength and automatic movement, and that could be worked as occasion offered, manually or otherwise. That he has succeeded in this is evident from a view of the steam hammer of his invention and construction, of which we present three designs.

Bell's patent steam hammer has a single column standard which, with the cylinder and bed plate, is cast in one piece; the die block being cast separately, it is strong, self-acting and takes steam at both ends of cylinder. The cylinder diameter is 10 inches; the stroke or lift 22 inches, and it will strike a blow of 6,000 pounds. The average diameter of shaft, which it will easily beat out at a single heat, is 7 inches.

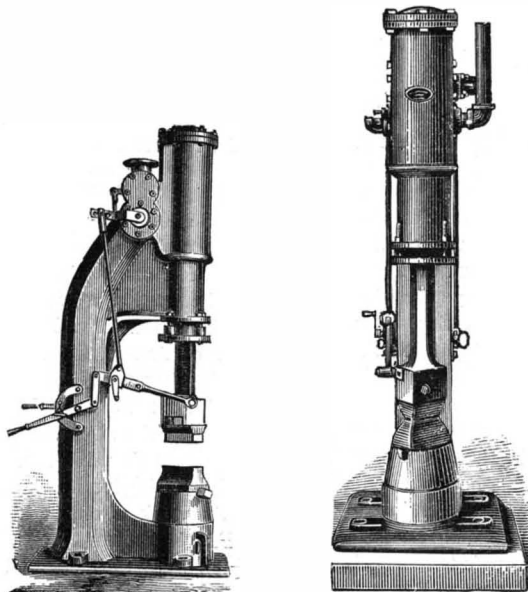

BELL'S STEAM HAMMER.

Two smaller sizes of steam hammers are made, having respectively 16 and 20 inches lift, and delivering a blow of 2,000 and 4,000 pounds. This hammer is economical in use, and its value in this respect and ready efficiency is testified to, as shown by numerous testimonials, from foremen, blacksmiths of leading establishments, and eminent engineering firms throughout the country.

Mr. Bell has completely suited the steam hammer to the ordinary smith's work, saving wages, time, fuel, and material, and securing improved execution. Wherever used it appears to have done valuable service, and has been classed not only as a useful but first class hammer. The Buffalo Car Works, Buffalo, N. Y., state that No. 3, which they use, presses into shape, without striking a blow, the bars and other iron work required for freight and passenger cars, and that they find it invaluable for the purpose.

Preserving Ripe Fruit.

That fruit can be preserved for a long time in a frozen state, and even in a non-frozen state, so long as the temperature does not exceed 32°, is a well known fact. But it is equally well known that articles so preserved lose flavor every day after they are so stored, and that when exposed afterward to an ordinary temperature they perish almost immediately. This happens to fruit when merely set on ice and not actually frozen; but it is certain that the freezing does not improve its chance of keeping, and very much depends on how the frozen mass is thawed, sudden thawing being mostly destructive to the tissues of either fruits or vegetables. For many years we have been in the habit of storing both fruit and vegetables in the ice house, but they are deteriorated by the treatment, and must be used immediately they come off the ice. In tin boxes we have kept peaches sound, though dead ripe when gathered, for a month, and nectarines for six weeks, in a perfectly spotless condition; but they lost flavor greatly toward the end of the time, and grew discolored almost before dessert was over, although only brought out of the ice house in time to be dished up for the table. By the following morning they had become quite black and useless.

Melons that would not keep more than a few days in the fruit room will keep a long while on ice, and retain their flavor longer than peaches. They, besides, are long in cooling, although the condensed moisture on their surface in the warm dining room would, to an experienced person, betray the quarter they came from, and they are much more refreshing than when warm out of the melon house or even the fruit room. In placing fruit on ice, the main thing to observe is not to pack it in any way or to wrap it in anything. It should be placed on a tray or in a tin box with a lid to keep off drip, but each fruit should be set out singly by itself and not come in contact with its neighbors, and great care should be used to prevent bruising, as that will greatly hasten decay when the fruit is taken out. It is not needful to bury the boxes quite in the ice; but they may be set in it with the lid of the box above the surface, so that any of the fruit can be got without trouble. Peaches, nectarines, melons, pineapples, figs, and other soft fruits that do not keep long, succeed best preserved in this manner.—*The Gardener (London).*

A New Photo-Electric Battery.

A new battery, which gives a current on exposure to the action of light, has been devised by M. Saur. It consists of a square glass vessel, containing a solution of 15 parts common salt and 7 parts sulphate of copper in 106 of water. A porous vessel of mercury is placed in the solution. An electrode of platinum is in the mercury, and another of sulphuret of silver in the saline solution. The electrodes are connected by means of a galvanometer, and the battery is fixed in a box sheltered from light. The closing of the circuit displaces the needle of the galvanometer, and it is seen that the sulphuret of silver is the negative pole. When the needle has come to rest, if the battery is exposed to the light of the sun the deviation increases. If the light is suppressed the needle returns to its original position; if a cloud passes before the sun while the battery is exposed to the light the variations of the needle indicate the fluctuations of the electric current. The effect of the battery is due to the action on the mercury of the bichloride of copper formed by the mixture of common salt and sulphate of copper. The protochloride of copper which is formed reduces the sulphuret of silver; but this reduction requires the intervention of the solar light, which determines the production of the photo-electric current.—*Les Mondes.*

Electricity in a Brewery.

A curious case of electrical generation by friction was recently brought before the German Electro-Technical Union by Dr. Werner Siemens, of Berlin. It was observed in a brewery in that city, and caused considerable alarm among the workmen. The brewery building is constructed of stone and iron, and the floor is laid with asphalt. In the upper story is a malt cleaner, from which the malt passes by an iron chute to the floor below, where it is received in wagons for distribution throughout the works. When the cleaner remained in action for some time the friction of the malt on the iron chute generated electricity, which produced a continuous stream of sparks. The malt itself crackled, and sparks flew from it to the hands of the workmen. When Dr. Siemens was called in to investigate the phenomenon, he showed how the asphalt floor insulated the malt room from the rest of the building, so that it became a large Leyden jar charged by the electricity generated by the friction of the malt rubbing on the iron chute and on itself.

Asbestos as an Insulator.

M. H. Geoffroy has brought before the French Academy of Sciences a specimen of electric lighting wire which appears to answer the purpose of preventing fires. It consists of copper wire insulated with asbestos and threaded through a lead pipe. According to experiments made at Paris by M. Henri Lippmann, engineer to the Faure Electric Accumulator Company, a specimen of the conductor of this wire was entirely volatilized by powerful currents without the leaden pipe being affected. The volatilization takes place in a mere fraction of a second, and the lead does not begin to fuse. Moreover, the asbestos acts as a good insulator for ordinary currents.

DECISIONS RELATING TO PATENTS.

United States Circuit Court.—Eastern District of Pennsylvania.

NELLIS vs. THE PENNOCK MANUFACTURING COMPANY.—PATENT HAY ELEVATORS.

McKenna, Cir. J.:

On the 18th day of December, 1866, letters patent, No. 2,429, for improvement in hay elevators, were reissued to Edward L. Walker. On the 29th of May, 1866, reissue letters patent, No. 2,260, for improvement in horse hay forks, were granted to Seymour Rogers, and on the 20th of March, 1866, letters patent, No. 53,345, for improvement in horse hay forks, were granted to Seymour Rogers. The title to these several patents is alleged to be vested in the complainant, and they constitute the subjects of the present controversy.

Several patents may be included in the same suit when their subjects are correlative and the inventions claimed are embodied in the same infringing machine. Demurrer for this cause overruled.

An assignee of the exclusive right to manufacture and sell a patented invention throughout the United States is the proper party to maintain a suit for the violation of this right. The right to manufacture and sell carries with it the right to use the devices sold, and nothing short of an express qualification will change this result.

If the agreements between the parties have defined their contracts, it is out of place for an entire stranger to them to seek to circumscribe their scope by a technical limitation of the spirit and sense which the parties have impressed upon them.

A grant of "the exclusive right under said recited letters patent to manufacture and sell a certain hay elevator" held not to be an assignment of an exclusive interest in the entire monopoly for the whole or any portion of the United States. It is a license only to manufacture and sell exclusively a specified form of hay elevator, and the representatives of such an interest are not indispensable parties to a suit upon the patent.

Scientific Results of the Jeannette Expedition.

The last number of *Der Naturforscher* contains a first attempt to lay down the scientific results of this expedition, in a paper by Herr H. Wichmann, based on the reports of Messrs. Melville and Danenhower, and of the naturalist of the expedition, Mr. Newcomb. It is known that after having passed, on August 31, the wintering station of the Vega, the Jeannette sailed north, toward Wrangell Land. But on September 5, when twenty miles northeast of Herald Island, she was frozen in, and during twenty-one months remained so, "the play of winds and currents." However drifted in different directions, she still advanced during all this time toward the northwest. The first wintering was north of Wrangell Land, which last proved to be a large island, and not a part of an Arctic continent, as had been presumed. The precious observations on aurora and magnetism which were made during the winter (about 2,000 measurements) are unhappily lost, as well as extensive collections of birds and of deep-sea fauna. The depth of the ocean in these regions was everywhere very small—thirty fathoms on an average, with a maximum of sixty and a minimum of seventeen fathoms. The bottom was usually a blue ooze, with a few shells and sometimes stones, which seemed to be of meteoric origin.

The ship still drifted toward the northwest, and on May 17, a small island, called Jeannette Island, was sighted in 76° 47' 28" N. lat., and 159° 20' 45" E. long. It was a rocky hill, covered with snow, situated on the eastern flank of a high mountain. Two days later another island was discovered toward the west, and an expedition under Mr. Melville reached it, with many difficulties, and landed on it on June 3, 1881. It was called Henrietta Island, and is situated under 77° 8' N. lat., and 157° 43' E. long.; it is rocky, and 2,500 to 3,000 feet high; the rocks are covered with nests of birds, but the vegetation is very poor, consisting of lichens and mosses, and of one species of phanerogam; all the island was covered with a sheet of ice and snow 50 to 100 feet thick, and a mighty glacier reached the sea on the north coast.

As is known, on June 13, under 77° 30' N. lat., and 155° E. long., the Jeannette was lost, the depth of the sea being there 38 fathoms. The crew, divided in three parties, went south, but ten days later they perceived that, owing to the drift of the ice, they had still advanced 27 miles northwest, being under 77° 42' N. lat. That was the highest latitude reached by the expedition.

On July 9 they perceived land, and after a hard journey reached it at a promontory they called Cape Emma (76° 38' N. lat., 148° 20' E. long.). This island, which received the name of Bennett, is a high mass of basalt, covered with glaciers; the island was crossed by a party, after two days' travel, and the north coast proved to be more hospitable than the south; it has several valleys covered with grass, where reindeer bones and driftwood were found; lignite was discovered on the south coast, and it is said that it would be quite useful for steamers. Dr. Ambler here collected fossils, as well as many amethysts and opals, but they were lost. The gulls were so numerous and so tame that hundreds of them were killed with sticks; the tides were regular, but very small, the level changing only two and three feet. The sea was free of ice in the west and south, and even in the northwest a "water-sky" was seen, so that M. Danenhower supposes that Bennett Island would be a good starting

place for future Arctic expeditions. It was only on August 30 that the expedition discovered the first traces of men on the Faddeyeff Islands; and its further advance toward the delta of the Lena is well known.

The scientific results of the Jeannette expedition cannot be yet completely appreciated, observes Herr Wichmann, but the notebooks and surveys of its members having been preserved, as well as a good part of the collections, it is to be expected that they will contribute to a great extent to increase our knowledge of this part of the Arctic Ocean. The discovery of three new islands confirms the statements of Sannirikoff, who stated he saw land from the Faddeyeff Islands, and renders probable the existence of a whole archipelago in that part of the ocean. The exploration of the fauna and flora of the New Siberian Islands, which never was done before during the summer, promises interesting results. The problematical *polynius*, which stopped the advance of the sledge parties of Hedenström, Wrangell, and Anjou, are not due to some warm currents, such having not been noticed during the temperature observations of the Jeannette; they are simple openings in the ice, such as are observed elsewhere. Finally, the search expedition must give most important corrections to the maps of the Siberian coast between the Olenek and the Yana river, which has not been visited for sixty years; the observations of the American expedition will correct many of the observations of Lieutenant Anjou. We may add to these expectations of Herr Wichmann that, as the Arctic law that "each polar expedition safely reaches the points which were sighted by the preceding one," will probably be true also for the North Siberian Seas, we must soon expect new and important discoveries in that direction, now that the way was opened to explorers of those parts of the Arctic seas.—*Nature*.

Cost of Carrying Coal on English Railways.

It is stated in the *Engineer* that a coal train of 300 tons, to run 100 miles, may be estimated for cost of running by the following method: The train would consist of thirty trucks, a brake van, and the engine and tender. The value of the rolling stock is thus made up: Engine and tender, £2,300; thirty trucks, at £70, £2,100; brake van, £120; total, £4,520. Interest and wear and tear are taken at 20 per cent—say, in round numbers, £900 a year. The average year's running would be 15,000 miles. It might be much more, and probably would seldom be less; but this is taken as a fair mean, though somewhat underestimated, so as to be on the safe side. The cost for interest on capital and wear and tear for running such a train 100 miles will be £6. The engine would burn about 50 pounds of coal per mile, representing a cost of something like 16s. per 100 miles for fuel. Wages of stoker, driver, and guard for the trip would come to about as much. The total cost of haulage of the 300 tons of coal per 100 miles is thus shown—with an addition of 8s. for grease, oil, water, and sundries—to amount to the round figure of £8, or 6'4d. per ton per 100 miles. To this must be added the charges relating to permanent way, working expenses at stations, rent, rates, and taxes, and other miscellaneous charges. The *Engineer* does not believe that these expenses will amount to three times the haulage; but even if they do, it is evident that the railway companies ought to be able to carry coal profitably for about 2s. per ton per 100 miles. It is equally certain that the railway charges for coal carriage are much more than this average, since the Great Western Railway rate from Wales to Paddington is 8s. 5d. per ton in fully loaded trucks; and the rate from the Barnsley district to London, by the Midland and Great Northern Railways, is 8s. 3d. per ton.

Completion of the Pacific Coast Cable.

The *Panama Star and Herald* says: On Friday, August 4, the steamships *Silvertown* and *Retriever* started from Pedro Gonzales Island, in the Bay of Panama, the former ship paying out cable to complete the section between that island and San Juan del Sur, Nicaragua. Mr. Parsoné, General Agent of the West Coast of America Telegraph Company, having volunteered to take charge of the temporary hut on Pedro Gonzales Island for the electrical tests, etc., necessary during cable laying, his services were accepted by Mr. R. K. Gray, and, with Messrs. Bailey, Norton, and Phillips, he remained at that island roughing it until Sunday last, when, learning by cable that the work at sea had been completed, they returned in the Pacific Steam Navigation Company's tender *Taboguilla*, which went to the island to bring them to Panama.

The steamship *Silvertown* returned, as already announced, on the 17th inst., with Mr. R. K. Gray on board, after having successfully completed the section to San Juan del Sur. The final splice of this section was slipped on the 10th, thus completing the telegraphic system of the Central and South American Telegraph Company.

Few persons are aware of the extent of this system, which runs from Lima to Payta, Peru; from Payta to Santa Helena, Ecuador; from Santa Helena to Buenaventura, Colombia; from Buenaventura to the Island of Pedro Gonzales, and thence to Panama; from Pedro Gonzales to San Juan del Sur, Nicaragua; from San Juan del Sur to La Libertad, in Salvador; and from La Libertad to Salinas Cruz, in Mexico. From Salinas Cruz a land wire crosses the Isthmus of Tehuantepec, and a cable thence from Coatzacoalco to Vera Cruz, Mexico, places the line in connection with the United States and the Old World. The total length of electrical cable connections completed by the company amounts to 3,170 knots, a figure which proves the enormous amount

of work which has been rapidly and successfully performed.

A flaw discovered in laying the Pedro Gonzales and San Juan del Sur section was easily removed within twenty-four hours of being discovered, and perfect communication through the whole line was re-established within twenty hours. The electrical tests were so accurately made that they located the flaw within one knot of its actual position. The main cable was at once grappled for and picked up in 700 fathoms of water. Reeling in was commenced, and very shortly afterward the defective piece was made good. The cable which was picked up was found within 500 yards of its location on the cable company's charts, a circumstance which proves the wonderful accuracy which must be observed by all concerned in such an extremely scientific and costly work as that which has now been so successfully and happily terminated.

The undertaking has been a great one. Now that it has been happily concluded, the few drawbacks which have been encountered having been overcome by foresight and knowledge, and the work having been performed on a coast hitherto almost, if not entirely, unknown to the promoters of cable enterprises, Mr. Robert Kaye Gray, and every one connected with his staff and the vessels, must feel satisfied with the satisfactory results which have attended their labors.

Slaking Lime.

A correspondent of the *Topfer Ziegler Zeitung*, treating of the slaking of lime, points out that quicklime can be divided into three classes: first, that which slakes into paste with water, and which may be called "whole burnt;" then there is the "half burnt" lime, which contains hard lumps after slaking; and the "over-burnt" lime, which, as its name implies, has either been subjected to too high a temperature, or has been burnt too long. In such cases there is an approach to vitrification, which is especially marked in limestone which contains clay. When it is desired to remove the two latter classes from a sample of lime, a layer of the material is to be spread out and sprinkled with water. When crumbling begins, it is easy to pick out the over-burnt and hard particles, and to continue the slaking by the continued addition of small quantities of water. Too hasty or excessive watering is to be avoided. The most suitable water for slaking lime is the softest that can be procured; if from melted snow or rain, so much the better. Spring water is usually too hard, and contains carbonic acid or carbonate of lime. Saline constituents in water also prevent its successful use for slaking lime; but, as a general rule, it may be assumed that the fewer carbonates there are in the water the more economical it will be for this purpose. In order to perfectly slake all the particles of lime the paste should be allowed to stand at least fifteen days before use; and should, during this time, be kept covered with ashes or sand. If lime is to be used for purifying gas in conjunction with any other material, as in Walker's patent, it is obvious from these considerations that the mixture should be prepared as long as possible before it is wanted, and that the ashes should be added when the quicklime is slaked.

The Contraction of Metals in Melting.

F. Nies and A. Winkelmann have examined the density of metals in a solid and in a liquid state, and find that, contrary to the generally accepted views on the subject, many melted metals expand when they solidify. The results of their experiments are embodied in a paper contributed to the Munich Academy of Sciences. Tin, slowly and carefully heated to its melting point, 2,265 degrees Celsius, floated on melted tin, and rose to its surface even after it had been submerged. By attaching pieces of copper to the floating tin it was found that the increase of density by melting over solid tin was 0.7 per cent., a difference which is almost as great as that between tin at the freezing and the boiling point of water. Lead and cadmium did not yield as decisive a result. Zinc, however, behaved like tin, but showed only a contraction of 0.2 per cent. In the case of bismuth the floating test is very easily carried out, as this metal shows as much as 3 per cent. Copper and iron showed a slight difference, the peculiarity in the case of iron being well known, and having been the subject of elaborate investigations by Wrightson in England.

Stopping the Engine by Electricity.

An ingenious method of instantly stopping machinery when in motion is said to be in operation at the Dominion Bolt Works, Toronto. A wire rope, coiled around the stem of the throttle valve of the engine, carries a weight which is held in place by a rest, and the whole arrangement is so placed that the passing of an electric current along a wire releases this rest and causes the weight to fall. The tension thus thrown upon the wire rope acts upon the throttle valve, cuts off the supply of steam, and consequently stops the machinery. Buttons, with wire connections, are placed in different parts of the works, and on pressing any one of these the passage of an electric current acts as above mentioned. In any factory these electric buttons can be placed in every room, or several of them in a large room, as may be required. Should any one happen to get caught by the machinery, the simple pressing of a button in the most distant part of the factory will stop the whole as quickly as could be done were the engineer standing ready to instantly obey a given signal.

Work and Wealth.

Edward Atkinson, at the opening of the Exhibition of the New England Manufacturers and Mechanics' Institute in Boston, summarizing the conditions of work and wealth in this country as compared to those abroad, concludes that ninety per cent of our working population earn their daily bread by their daily labor. The great problem is to make the struggle for life easier, and the first requirement toward its successful solution is to develop hand and brain together so as to increase the purchasing power of every dollar. We are the most wasteful nation in the world, mainly because there is greater abundance here than elsewhere. Our crops might be increased one-half by applying the last discoveries of science to our methods of agriculture. Economy in machinery is the field that will yet yield the best results. The best steam-engine and boiler waste nine-tenths of the potential energy of the fuel it consumes. In our great locomotives and heavy trains of cars only one pound in a hundred of the fuel used is actually applied to the movement of the load. In the self-operating carding engine, spinning-frame, and loom, four-fifths of the power is wasted in operating them, and in putting cotton fiber into cloth three-fourths of its original strength is lost by rough treatment. Half our vast crops of food and more than half our fuel are wasted before their work is done. Saving in this and in every other form of production or transportation goes, for the largest part, to the benefit of consumers and helps them in the work of gaining their subsistence. Every application of science to manufacturing industry, to mining or agriculture, by which the aggregate of things is increased, while the labor is diminished, tends to increase the commodities to be divided among the laborers and enriches the workmen in far more rapid proportion than the capitalist. The great purpose of world's fairs and local exhibitions is to bring into prominent notice every new application of science by which production may be increased, and to develop the natural resources of the country. They are great object-lessons in human welfare. The first requisite, however, is to qualify boys and girls, men and women, to take advantage of the opportunities thus spread before them. If methods of industrial instruction can be added to the mental training of the public schools, if the hand and the head can be educated together, the causes of want may be wholly removed.

The greater the skill, the larger gain alike to workman and capitalist. The more effective the application of labor and capital, the larger the profit to the latter and the payment to the former. Abroad, a large proportion of the annual product of labor is taken from the people to maintain great standing armies. Measured by the standing armies of France and Germany, the United States, with its population of fifty-four millions, would have to keep seven hundred thousand men in arms, more than one in twenty of all the adult males in the country, who would be withdrawn from the producers to become consumers only, and one man in every nineteen of those remaining would be forced to labor in order to pay the taxes necessary to sustain the seven hundred thousand idle men. We keep that army to work in the field, the forest, the mine, the ship, the workshop, the office, the school, in building houses and railroads, etc.

The cost of the great European armies of destruction is more than equal to the sum of all the wages earned in this country by all the iron miners, all the iron workers, and all the men, women, and children in our textile factories put together. The wages and earnings in this country are higher than in any land burdened with great standing armies. The quantity of things to be divided, the true earnings must be just so much greater, and the cost of making them just so much less. The last man or woman discharged in hard times is the one earning the most. The first to be discharged is the one that does the least work and earns the least wages. As it is with persons, so it is with whole countries. Where the conditions are best, where the natural resources are the greatest, there will be found the most skillful workers, the best machinery, and the largest production. The lowest cost is always measured by the highest wages of those who do the work that is most important. Where mental capacity and manual dexterity are combined and applied to the best machinery, there will be found the largest production, the highest wages, and the safest and most adequate return for capital. This country has the advantage over all others in its natural resources, capable of being worked with the least effort, in its widespread education, which, even if it is imperfect, yet, on the whole, does qualify its pupils to apply the greatest versatility, and to combine mental and manual capacity to the greatest advantage, and, in its freedom from destructive taxation. Our higher wages are the sign of low cost, and the product of a single day's work of machinery, directed by one skilled man, will buy the product of fifty days' labor in the coffee plantations of Java or Brazil, or of one hundred days' labor in the tea fields of China, or of twenty days' labor in the sugar plantations of Cuba, or the hemp fields of Manila, or of ten days' labor in the wool-growing sections of South America or Australia. To utilize our strength, we must perfect our methods of instruction in the application of science to the useful arts.

Every mechanics' fair, every Franklin Institute Exhibition, ought to be a convincing appeal to the successful manufacturer, the great iron worker, the large coal miner, to give of his abundance to the endowment and establishment of industrial schools. The best possible investment of present profits for future returns is in liberal aid to the struggling schools where the higher branches of technical education are taught, with manual instruction in the mechanic arts, and to the development of the great work of instructing the brain and hand to work together. The supply of skilled workmen has never yet been in excess of the demand. Boys trained in a knowledge of tools and in the principles that underlie all mechanics are needed in every workshop, and the country has need of all the skill that education can give.

There is much in the above, put in such sententious and rather positive style, that is subject to dispute; but Mr. Atkinson being a practical manufacturer, well acquainted with the large industries of the country, and a broad and competent observer and thinker, what he says on such subjects is well entitled to the thoughtful attention of all who give intelligent consideration to these important matters.

THE GREAT COMET OF 1882.

Telescopic and naked eye observations were made at my observatory of this fine comet on the mornings of the 24th and 25th inst. The comet was discovered by Cruls, at Rio Janeiro, on the 14th of September, and was at one time so brilliant as to be seen with the naked eye within a few degrees of the sun at noonday. It is now passed perihelion, and has moved so far west of the sun as to be visible in the eastern sky before sunrise.

The accompanying drawing represents the comet's appearance as seen by me on the 24th of September before sunrise. Its appearance was magnificent, the head and peculiar shaped wings glowing like burnished silver on the bright yellow twilight of the eastern sky. The tail, even in the

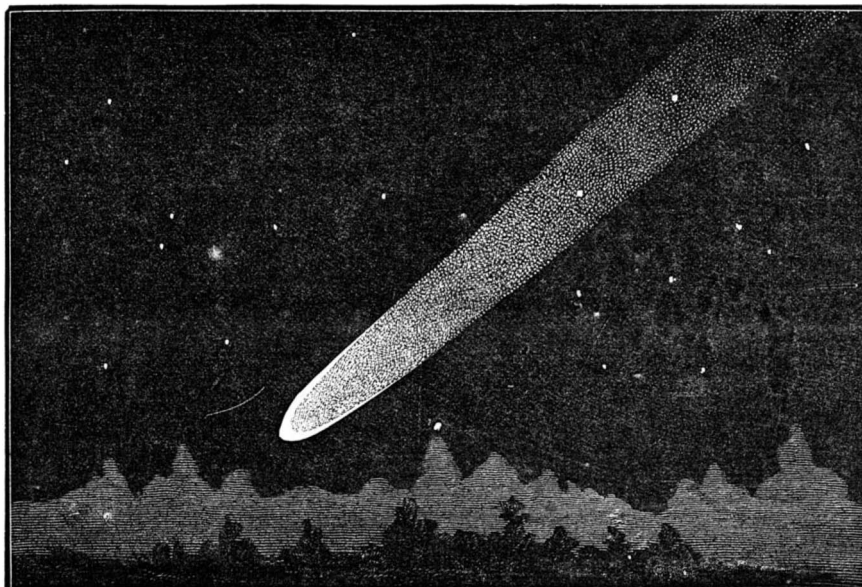

COMET ACCORDING TO BROOKS' SKETCH.

brightness of approaching day, could be seen extending upward, and nearly parallel to the ecliptic, to a distance of from twelve to fifteen degrees, and by glimpses much further. As it moves west, and after a time rises before dawn, the tail will doubtless be visible to a great distance from the head. It is believed by some eminent astronomers to be identical with the great comets of 1843 and 1880—the latter discovered by Gould in South America—and by some powerful influence is having its period rapidly shortened, but this as yet is not conclusive. As it will be visible some time to the naked eye, and much longer telescopically, it will be attentively observed. WILLIAM R. BROOKS, Red House Observatory, Phelps, N. Y., Sept. 25, 1882.

A Glacier on Sale.

The enormous glacier Fonor Svartisen, on the Senjen Island in Norway, which is the northernmost of its kind in Europe, will shortly, says *Nature*, be made the object of a remarkable enterprise. It appears that a number of speculative merchants in Bergen have obtained the right of cutting block ice for export from its surface. Some blocks have already arrived at the latter place, and as the quality of the ice has been found to be good, large shipments may be expected. The glacier is about 120 square miles, and as the distance from its border to the sea is only a couple of miles, the ice may be obtained very cheaply. A similar attempt to utilize the glacier Folgefonden was made some years ago, but failed, owing to the blocks in their downward course repeatedly breaking through the wooden bore or conductor in which they were slid down to the sea.

Electricity in the Shoe Factory.

An attractive feature of a model shoe factory in the Cincinnati Industrial Exposition appears in the application of electricity as a conveyer of power for driving the Goodyear Sewing Machines used in the manufacture of ladies' fine shoes. This is believed to be the first time that shoes have been bottomed by electricity.

Code of Rules for the Erection of Lightning Conductors.

The following rules, from the "Report of Lightning Rod Conference," 1882, published by Messrs. E. and F. N. Spon, have been abstracted under the directions of Major V. D. Majendie, H. M. Chief Inspector of Explosives, and sent by the Explosives Department of the Home Office to the occupiers of factories, magazines, or stores of explosive materials, and to the police authorities. Reasons, based on practical and theoretical evidence are given at length in the report for each rule and recommendation:

1. *Material of Rod.*—Copper, weighing not less than 6 ounces per foot run, the electrical conductivity of which is not less than 90 per cent of that of pure copper, either in the form of rod, tape, or rope of stout wires, no individual wire being less No. 12 B. W. G. (0.109 inch). Iron may be used, but should not weigh less than 2¼ pounds per foot run.

2. *Joints.*—Every joint, besides being well cleaned and screwed, scarfed, or riveted, should be thoroughly soldered.

3. *Form of Points.*—The point of the upper terminal* of the conductor should not have a sharper angle than 90 degrees. A foot below the extreme point a copper ring should be screwed and soldered on to the upper terminal, in which ring should be fitted three or four sharp copper points, each about 6 inches long. It is desirable that these points should be so platinized, gilded, or nickel-plated as to resist oxidation.

4. *Number and Height of Upper Terminals.*—The number of conductors or upper terminals required will depend upon the size of the building, the material of which it is constructed, and the comparative height above ground of the several parts. No general rule can be given for this, except that it may be assumed that the space protected by a conductor is, as a rule, a cone, the radius of whose base is equal to the height of the conductor from the ground.

5. *Curvatures.*—The rod should not be bent abruptly round sharp corners. In no case should the length of a curve be more than half as long again as its chord. A hole should be drilled in string courses or other projecting masonry, when possible, to allow the rod to pass freely through it.

6. *Insulators.*—The conductor should not be kept from the building by glass or other insulators, but attached to it by fastenings of the same metal as the conductor itself is composed of.

7. *Fixing.*—Conductors should preferentially be taken down the side of the building which is most exposed to rain. They should be held firmly, but the hold-fasts should not be driven in so tightly as to pinch the conductor or prevent contraction and expansion due to changes of temperature.

8. *Other Metal Work.*—All metallic spouts, gutters, iron doors, and other masses of metal about the building should be electrically connected with the conductor.

9. *Earth Connection.*—It is most desirable that, whenever possible, the lower extremity of the conductor should be buried in permanently damp soil. Hence proximity to rain water pipes and to drains

is desirable. It is a very good plan to bifurcate the conductor close below the surface of the ground, and to adopt two of the following methods for securing the escape of the lightning into the earth: (1) A strip of copper tape may be led from the bottom of the rod to a gas or water main—not merely to a leaden pipe—if such exist near enough, and be soldered to it. (2) A tape may be soldered to a sheet of copper, 3 feet x 3 feet x ¼ inch thick, buried in permanently wet earth and surrounded by cinders or coke. (3) Many yards of copper tape may be laid in a trench filled with coke, having not less than 18 square feet of copper exposed.

10. *Protection from Theft, etc.*—In cases where there is any likelihood of the copper being stolen or injured it should be protected by being inclosed in an iron gas pipe reaching 10 feet—if there is room—above ground and some distance into the ground.

11. *Painting.*—Iron conductors, galvanized or not, should be painted. It is optional with copper ones.

12. *Inspection.*—When the conductor is finally fixed it should, in all cases, be examined and tested by a qualified person, and this should be done in the case of new buildings after all work on them is finished.

Periodical examination and testing, should opportunities offer, are also very desirable, especially when iron earth connections are employed.

A Taxidermists' Exhibition.

At a meeting of the Executive Committee of the Society of American Taxidermists, in Washington, Oct. 3, it was decided to hold the third annual exhibition in New York, from December 4 to 16, 1882, at Armory Hall, in Central Park. The following gentlemen were elected as a board of exhibition commissioners: Jacob H. Studer, President; Professor G. Brown Goode, Vice-President; Dr. Joseph B. Holder, Secretary; Andrew Carnegie, Treasurer; Professor A. S. Bickmore, Robert Colgate, James C. Beard, Dr. Wendell Prime, and Professor Henry A. Ward.

*The upper terminal is that portion of the conductor which is between the top of the edifice and the point of the conductor.

IMPROVED STATIONARY ENGINE.

The annexed engravings represent a style of girder frame stationary engine built by the Taylor Manufacturing Company, of Westminster, Md., from 4 x 7 cylinder to 10 x 12 cylinder, or from 3 to 20 horse power. This engine, which the manufacturers call the "Tiger Stationary Engine," was recently designed by the company to be built as a portable or a stationary engine, and it can be equally as well built

The shaft is of steel, and carries a balanced disk, and the shaft and the crank pin are forced into the disk by hydraulic pressure. The crank pin is large and of the best steel. Connecting rod is of forged iron with solid ends, in all sizes up to 8-inch cylinder; the four larger sizes are made with locomotive straps having square ends. The cross-head is made with adjustable gibs, and is very easily adjusted; cross-head pin is of steel, and arranged to take up all wear.

This company, besides the above engine, manufacture the Dry Steam Portable, from 8 to 40 horse power; Climax Portable, from 12 to 40 horse power, which can also be used as a stationary; vertical, from 5 to 10 horse power; portable engines after the pattern of the stationaries illustrated, from 3 to 20 horse power; stationary cut-off engines, from 12 to 250 horse power, and five sizes of circular saw mills. They are building new and extensive works at Chambers-

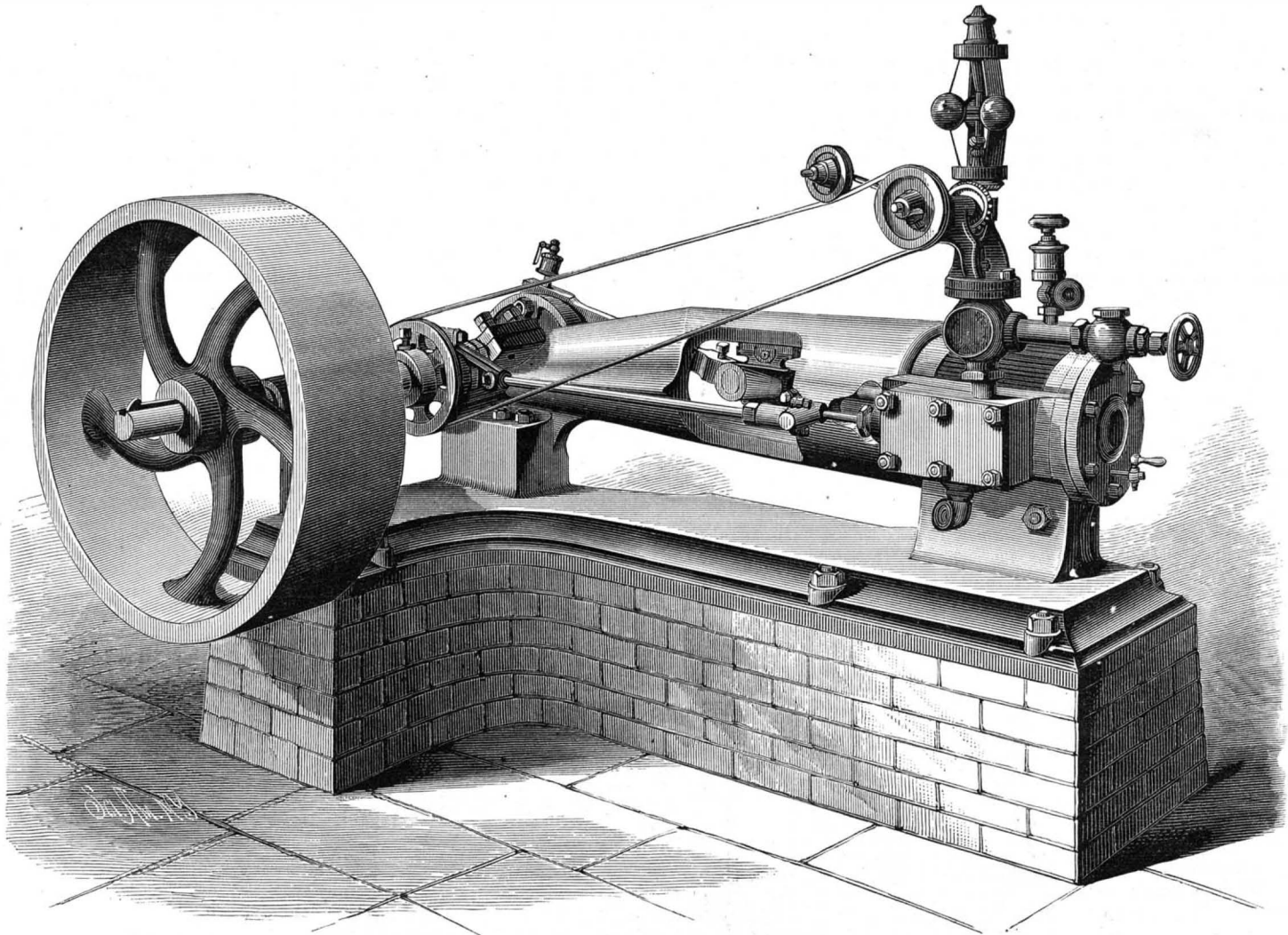

"TIGER" STATIONARY ENGINE.—REAR VIEW.

as other engines by the same manufacturers, and can be sold at a less price.

As a portable, the bed plate is dispensed with, and in the smaller size the engine is bolted directly to the boiler; in large sizes it is secured to brackets on boiler. When used as a stationary, it is bolted to a bed plate, as shown in engravings, and, as both bearings are on the bed plate, the engine is self-contained, and any failure of foundations will not affect its working.

Piston is fitted with adjustable packing, and is not liable to get out of order. The Pickering governor is used in connection with this engine; it is very sensitive and economical in its use of steam. The valve is of the usual D valve pattern, proportioned on correct principles; the steam ports are large and distance to cylinder short, giving the best results in a quick acting machine. It is a strong, stiff engine, attractive in appearance, and, as we are informed, can be sold at a low price.

burg, Pa., and will move their entire plant there in November next, where they will have excellent facilities for handling their large and growing trade. Further particulars may be obtained by addressing Taylor Manufacturing Company, Westminster, Md.

Of the 600,000 tons of fertilizers sold annually in the United States, Baltimore furnishes one-third, or 200,000 tons.

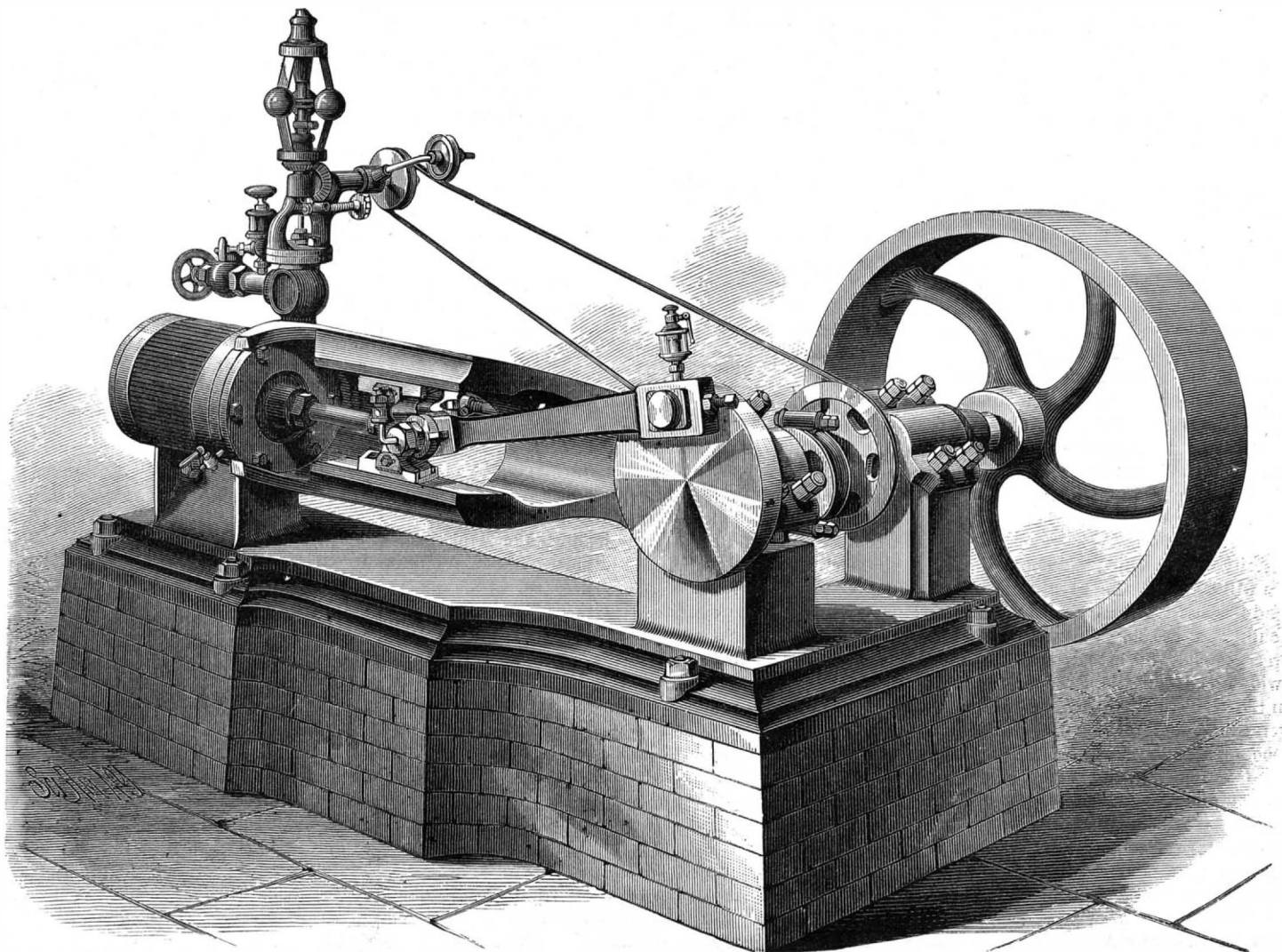

THE "TIGER" STATIONARY ENGINE, MADE BY THE TAYLOR MANUFACTURING CO.

THE NEW FOOD FISH.—(*Sebastes dactyloptera*.)

Mention was made last week of the discovery by Captain Collins, in the service of the United States Fish Commission, of a new and promising food fish. The fish was taken, it will be remembered, while trawling for tile fish in deep water off the south coast of Long Island.

At the National Museum, in Washington, the fish was recognized as the *Sebastes dactyloptera*, young specimens of which were taken in great abundance by the Fish Hawk, off Newport, R. I., in 1880, along the edge of the Gulf Stream, in 100 to 150 fathoms of water.

The fish recently taken were the first adult specimens caught off the American coast. Professor Goode states, however, that the fish is found in great abundance around the Madeira Islands, where it is popularly known as the "catseye," and highly esteemed as a food fish. In general appearance it closely resembles the red perch or Norway haddock, which is so plentiful along the coast of Maine. The fish run from two to three and a half pounds in weight.

The engraving herewith is from a fine drawing by Daniel C. Beard, of the specimen in the possession of Commissioner Blackford, at Fulton Market. Mr. Beard describes the fish as follows:

The specimen Mr. E. G. Blackford has is rather smaller than the average, some of the fish weighing four pounds or over. Mr. Blackford, with his usual good nature, not only allowed me the use of his office, but had his specimen of the new fish removed from the glass jar that I might be enabled to make an accurate drawing of it. The alcohol had bleached the brilliant red color of the fish until it appeared of a light orange tinge; irregular small brown spots are scattered over the top of the head, back, and sides, above the lateral line, as far as the termination of the second dorsal fin. A few spots are scattered sparsely over space below the lateral line and above pectoral fins. The pectoral fins are no longer "blood red," but have a faded orange color, with a touch of lake on the lower rays. The belly is inclined to a light purplish lake, and the ventral fins are of the same color. The tail seems to retain its color better and is still of a brilliant goldfish red. From tip of nose to end of tail Mr. Blackford's alcoholic specimen measured 10 inches; from tip of nose to end of operculum, $3\frac{3}{4}$ inches; perpendicular distance through body at second spine of first dorsal fin, $3\frac{1}{2}$ inches; thickness or horizontal distance through body at pectoral fins $2\frac{1}{4}$ inches. Head large and ornamented with small spiny points; very large eyes, 1 inch in diameter, situated half an inch above the mouth, and extending to the top of the head. Three diagonal parallel spots of brownish color on the top of the eye; operculum triangular in form, with apex upon a level with the eye; center of operculum marked by a dark bluish spot; outer border of operculum fleshy; two small spiny points respectively two-eighths and five-eighths of an inch below apex of gill cover; scales at irregular intervals. Bony ridge ornamented with seven spiny points commences at a point half an inch in front of first dorsal fin, runs down face, separating top of eye from top of head, and joining another ridge on nose; this second ridge runs back, forming the lower edge of the orbit, and terminates at the second spine of the preoperculum; two small spiny points in front of nostrils. Length of mouth, $1\frac{1}{4}$ inches. Fine teeth upon upper and lower jaws; fleshy space in center of upper lip, destitute of teeth; a small protuberance on lower jaws fits in this space when mouth is closed. Preoperculum covered with small scales; lower edge armed with five bony points. Five branchiostegous rays. Fins: first and second dorsal joined, and lower parts enveloped in integument; first dorsal composed of ten spines; second dorsal, one spine and twelve soft rays; at highest point fin is one inch above back; pectoral fins composed of nineteen soft rays, the lower eight of which terminate in flexible points free for distance of from a quarter to three quarters of an inch; length of fin, 2 inches; breadth of fins at base, $1\frac{1}{8}$ inches; breadth at outer edge when expanded, 2 inches; ventral fin situated below and $\frac{1}{4}$ inch back of base of pectoral fins, one hard spine and five soft rays; anal fin located 6 inches from tip of nose and $1\frac{1}{2}$ inches back of anus, composed of two hard spines and five soft rays; caudal fin is 2 inches long and 1 inch perpendicular width at base; small scales extend between rays to a point within three-eighths of an inch of top of tail; when expanded tail measures $1\frac{1}{4}$ inches, very slightly notched. Lateral line commences at the termination of bony ridge above eye, with three spiny points following the edge of the gill cover; it curves down from the apex of the operculum to a point three quarters of an inch below the sixth dorsal ray; thence it runs in almost a straight line to neck of tail half an inch below dorsal fin; thence parallel to neck of tail to point where caudal rays commence.

In St. Petersburg the snow is thrown into pits and melted by steam.

Pier Building in Paris.

An interesting expedient was successfully used for laying the foundations for the new dry goods store, the "Printemps," now building in Paris on the site of the one destroyed by fire last year. The new structure is to be entirely fire-proof, and although the disposition of the upper stories made it advisable to plan the foundation in a series of piers, it was necessary, says the *Amer. Architect*, to make these piers very firm, and carry them down to a stratum of unquestionable solidity. The ground under the site was, however, of a character very ill-adapted for deep excavation. It was a loose sand, saturated with water, and although the firm rock was found about six feet below the water level, any removal of the sand for trenches was sure to be followed by caving in of the sides, and very probably by the undermining of the adjoining buildings. It was therefore decided to employ for depositing the piers a modification of the caisson and airlock now used in bridge building. Tubes of sheet iron, six to nine feet in diameter, and about six feet long, were provided, in number equal to that of the piers to be constructed. Each of these had at the top a projecting flange, by which it could be bolted to a hollow cone, also of sheet iron, the joint being made tight with India-rubber. This cone had a man-hole door at the top fitting air-tight, and over it could be placed a second cone, which was bolted to it, and also had an air-tight door. The space between these two cones formed the air-lock. The caisson tubes were first placed in position, and the double cone was set up over one of them, and when all was made tight the workmen placed inside began to excavate under the rim of the tube. As this sank by its own weight, air was pumped into the cones in sufficient quantity to force back the water which would otherwise enter beneath, and the laborers thus



THE NEW FOOD FISH.—(*Sebastes dactyloptera*.)

worked in dry ground until the caisson had sunk to its hard bed. The excavated material, instead of being thrown out, was deposited in the bottom of the air-lock, occupying the narrow space between the lower part of the outer and inner cones. When all was excavated, a "beton tube," consisting of a small, separate air lock, with double doors, was attached to the man-hole of the upper cone. This was alternately filled with concrete through the upper door by workmen outside, and emptied into the bottom of the caisson by men stationed in the air-lock between the two cones, who opened the door of the lower cone simultaneously with the lower door of the beton tube. The laborers in the caisson spread and rammed the concrete as it fell, until the pier was complete; then they ascended to the outer air, the bolts were loosened, and the beton tube and the upper cone were lifted off. The removal of the upper cone allowed the excavated material, which had been deposited in the bottom of the air-lock, to slide quietly off on all sides, and the inner cone was then lifted and carried away, to be replaced on top of the next caisson. This ingeniously simple contrivance answered its purpose admirably, and the time occupied for building each pier, including all the adjustments of the cones and tubes, was only about twenty-four hours.

Waterproof Leather.

The fat having been removed, the clippings are mixed with starch paste, some gum arabic, and about one per cent alum, and pressed into plates. It is then treated with a solution of soda soap, and pressed again. Thus it becomes impregnated with fatty aluminous compounds. Greased leather clippings are first to be treated with sodium silicate or caustic. The resulting soap is then rendered insoluble by impregnating with alum or zinc sulphate.—*E. Poluk.*

Warm Milk a Health Restorer.

Considerable has been lately said in medical journals concerning the value of warm milk as a remedial agent in certain diseases. The *Christian at Work*, referring to an interesting article on this subject which lately appeared in the *London Milk Journal*, states, on the authority of Dr. Benjamin Clarke, that in the East Indies warm milk is used to a great extent as a specific for diarrhea. A pint every four hours will check the most violent diarrhea, stomach-ache, incipient cholera, and dysentery. The milk should never be boiled, but only heated sufficiently to be agreeably warm, not too hot to drink. Milk which has been boiled is unfit for use. This writer gives several instances in arresting the disease, among which is the following:

The writer says: "It has never failed in curing in six or twelve hours, and I have tried it, I should think, fifty times. I have also given it to a dying man who had been subject to dysentery eight months, latterly accompanied by one continued diarrhea, and it acted on him like a charm. In two days his diarrhea was gone; in three weeks he became a hale, hearty man; and now nothing that may hereafter occur will shake his faith in hot milk. A writer has also communicated to the *Medical Times and Gazette* a statement of the value of milk in twenty-six cases of typhoid fever, in every one of which its great value was apparent. It checks diarrhea, and nourishes and cools the body. People suffering from diseases need food quite as much as those in health, and much more so in certain diseases where there is a rapid waste of the system. Frequently all ordinary food, in certain diseases, is rejected by the stomach, and even loathed by the patient; but nature, ever beneficent, has furnished food that in all diseases is beneficial—some directly curative. Such food is milk." The writer in the journal last quoted,

Dr. Alexander Yale, after giving particular observations upon the point above mentioned, its action in checking diarrhea, its nourishing properties, and its action in soothing the body, says: "We believe that milk nourishes in fever, promotes sleep, wards off delirium, soothes the intestines, and, in fine, is the *sine qua non* in typhoid fever."

We have lately tested the value of milk in scarlet fever, and learn that it is now recommended by the medical faculty in all cases of this often very distressing children's disease. Give all the milk the patient will take, even during the period of greatest fever. It keeps up the strength of the patient, acts well upon the stomach, and is in this way a blessed thing in this sickness.

Inventors in the Market.

One of the secrets of the rapid progress of invention in modern days is the practical encouragement afforded it in the publicity attaching to any improved devices, and the readiness with which capital can be secured for any solid advance in chemical science and constructive art. A new machine brought out, if of sterling merit, being widely advertised, creates in this country a wide demand. A host of our leading manufacturers are solely dependent upon the growth of the demand for machines made in numbers. There are many mechanic productions which, so long as the demand is limited, cannot be made profitably by expensive machines, and hand labor is resorted to. There are plants which will not pay unless thousands and even tens of thousands of given articles are turned out. We need scarcely remark that inventions that come into such general use as to justify a large outlay of capital in production are such as meet well defined and general needs, particularly in removing previous imperfections, doing work better, and saving labor. An inventor often makes an improvement which is not important enough to justify any great investment of capital in pushing it. Further, a host of patents are taken out which do not rank higher than variations in form and processes, without compensation in the better accomplishment of results. Many inventions are made by chance, but most can be traced to men who, with suggestive minds, have a good knowledge of the class of work to which their inventions pertain, and have discovered the mode of securing better results either in more work or doing this more efficiently and economically. All invention may be traced to single-handed intermittent individual enterprise. Such are the facilities of bringing inventions forward that the world is wisely disposed to judge the merits of inventions by the extent of their acceptance.—*The Trade Review.*

Electric Lighting on the Pennsylvania Railroad.

The Pennsylvania Railroad Company have taken the lead in experiments looking to the adoption of electric lamps for passenger cars. The electric storage is accomplished by the use of secondary batteries underneath the floor of the cars, thirty cells of battery furnishing current for six Edison lamps for seventeen hours. Test experiments made September 19 are said to have been very satisfactory to the officers of the company.

CRYSTALS.

BY WILLIAM JAGO, F.C.S., ASSOC. INST. CHEM.

The well known "lead tree" depends on the fact that zinc is a more active element, chemically, than lead; hence, if zinc be introduced into a solution of a compound of lead with an acid, the lead is "displaced," and its former position usurped by the zinc. The lead is deposited in the metallic state, and under favorable conditions assumes a beautiful crystalline form. The experiment of making a lead tree may be performed with a *minimum* of apparatus and experience of chemical manipulation. An ordinary pickle bottle, or other vessel of clear glass and similar shape, being obtained, fill it with a solution of lead acetate (sugar of lead). About an ounce of the acetate will be sufficient for a bottle of the size mentioned; if dissolved in spring water, a slight sediment will be formed—this, however, if allowed to subside, will not interfere with the experiment. Distilled or even rain water is preferable for making chemical solutions. Next a fragment of *clean* zinc, about the size of a small walnut, must be procured, the more irregular the better; suspend this by a piece of string, the end of which passes through a hole bored in the cork of the bottle containing the acetate. Put the zinc in the bottle, cork it up, and so arrange the length of the string that the zinc is just beneath the neck; fasten it in this position, and set the whole arrangement where it will not be disturbed. In a short time crystals of lead will be seen to deposit themselves on the zinc, and soon it will be covered with a tree-like growth of crystals. If left perfectly still, it remains a long time before the mass drops off. With this and other similar experiments, one half the pleasure consists in watching and studying the crystal growth for one's self.* Silver, which is in many respects a metal closely allied to lead, may also be made the subject of interesting experiments on crystallization; the so-called *Arbor Diana* is produced by placing a globule of mercury in a solution of nitrate of silver; a growth ensues of long thin crystals of an amalgam of silver; these, in addition to their beauty of shape, possess that magnificent luster which causes mercury and silver to be almost unrivaled among the metals.

Those who possess a microscope will find a few prepared specimens of crystals a valuable addition to their stock of slides. Not only are they of great interest, but as an introduction to microscopic analysis and microscopic study of rocks, the systematic student will find them worthy of special study. It has been previously stated that the crystalline form of many substances is one of their most characteristic properties; and as in the detection of poison and other important cases there is often a trace merely of the substance to be obtained, a microscopic examination is of great importance; it has, too, this further merit, that the substance is afterward available for other chemical tests.

The preparation of such slides is very simple. In the first place, the glass slips must be perfectly clean and free from grease; it is well to wash them in a solution of soda, rinse with rain or distilled water, and then wipe dry with a clean linen cloth. The substances that may be selected for study are legion; those figured are very suitable for a first attempt; make solutions by putting a pinch of common salt, potassium nitrate (saltpeter), oxalic acid, and potassium dichromate in separate clean test-tubes, and add to each a teaspoonful of water, they will dissolve rapidly to clear solutions. Take a drop out of the common salt test-tube on the end of a glass rod, and place it on a clean slide, spread the drop out with the rod in as thin a layer as possible; warm the slide very gently over a lamp until the salt begins to crystallize round the edge of the drop, then place it under the microscope and watch the progress of crystallization. Little cubes of salt will be seen to form, and ultimately the field will appear as shown in Fig. 1.

Precisely the same experiments being made with the other solutions, the shapes of the respective crystals are shown in the accompanying figures. Potassium nitrate differs remarkably from the salt; instead of the little cubes, we have the crystals arranged in long parallel feathers. The oxalic acid, again, shows forms differing from the other two; from a center the crystals radiate out in every direction. Of the four specimens, however, the potassium dichromate is the most beautiful; the crystals, instead of being colorless, are of a deep amber hue, while, in mode of arrangement, they resemble a fern group rather than mere inanimate matter. The figures must be looked on as giving some idea only of what is actually seen. The leading outlines have been drawn, but to copy the delicate tracery of the finer crystals is impossible. In the case of the potassium dichromate in particular, some parts of the field defy all attempts at even affording a conception of their exquisite beauty. But were even all this possible, there is yet the greater charm remaining to the actual worker, and that is to see the growth proceeding. The specimen being so placed that the edge of the crystals already formed is just within the field, the main

* It should be stated that lead acetate is a poisonous salt. In all cases chemicals should be kept clearly labeled and locked up.

lines shown are first rapidly filled in, and then the smaller branches dart out until, the water having evaporated, the whole of the salt has regained the solid state.—*Knowledge*.

On the Utilization of Bones.

It was through the endeavors of Liebig and Stöckhardt that the value of bones as a manure was fully recognized, and a great many establishments were erected to reduce them to a state fit for agricultural purposes. The bones, without any further preparation, were ground by crushing machines, thus producing the "crude bone dust." This primitive manufacture was, after some time, abandoned, and is now only used for certain special and limited purposes. More recently, to effect a readier pulverization, by rendering the bones more brittle, treatment with milk of lime was recommended. This having been unsuccessful, heating them in steam was tried, and, at the same time, it was found that the large amount of fat yielded would give a valuable by-product. Thus an independent manufacture rapidly arose. For the separation of fat, the bones, after having been sorted out and broken up by some appropriate means, are boiled with water in boilers heated by steam.

These vessels have grown in size from one-half to six cubic meters capacity. The bones are immersed in them in boxes made of iron bars, and steam is injected as long as any appreciable quantity of fat gathers on the surface of the water. This is then skimmed-off, and, mostly without further purification, sold to soap manufacturers, as it is rich in fatty acids. The production of fat depends on circumstances; on an average it is 2 to 4 per cent, of select fatty bones it is 6 per cent. The extraction of fat by boiling with water is always very imperfect, up to 6 per cent of fat remaining behind in the bones. A great step was therefore taken, when, two years ago, Seltam-Forchheim introduced the extraction of fat by petroleum spirit (benzine), in an apparatus ingeniously constructed. This method allows of bones of all kinds being extracted, it makes the production of fat double and even triple as large, and yields a fat of better quality. The bones thus extracted are exposed to the action of steam of $1\frac{1}{2}$ to 3 atm., in order to swell the gelatin and break the solidity of the bone. The juice which condenses with the steam is either sold to farmers or concentrated to a jelly. It is preferable first to extract the fat before

arrangement of flues. Proprietors of cylindrical ovens do not complain of difficulties in selling their produce. The freshly-prepared charcoal energetically absorbs water and gases from the air. It is therefore wetted, and it is well that so much water should be taken up, that the charcoal contains 6 to 7 per cent of it, as this will keep constant. In addition to the products mentioned there is glue prepared from bones. The washed bones are treated with hydrochloric acid, until they can be squeezed together with the hand, *i. e.*, till all earthy matter is dissolved. The crude gelatin, which then remains behind, is worked into glue in the ordinary way, after the acid has been washed away. This kind of glue is inferior in quality to that prepared from leather, and the process of extraction has now lost a great deal of its profitability, owing to the rising price of hydrochloric acid, although, on the other hand, precipitated phosphate of lime is obtained as a valuable by-product, its phosphoric acid being soluble in citrates.

The manufactured bone-glue has also been combined with that of bone-dust. On steaming and boiling the bones a part of the glue is dissolved. From this a glue in the form of a jelly was at first prepared and brought to the market. It has, however, gradually been improved, and now, by extracting the bones with steam, a solid glue can be obtained, which successfully competes with the best kinds known. For the preparation of this it is essential to obtain a concentrated glue-juice expeditiously, without overheating it. This is best effected by the new patent process of Abr. Zwilling, who proposes to alternately conduct steam and pump air in during the extraction. The glue-juice thus obtained is bleached by a current of sulphurous acid, and is, after clearing, ready for concentration. The residue from the extraction, which can easily be powdered when dry, furnishes a bone-dust of $1\frac{3}{4}$ to $2\frac{1}{2}$ per cent nitrogen, and 26 to 28 per cent phosphoric acid, which can be sold at a moderate price. This also may be converted, by treatment with sulphuric acid, into a superphosphate, which cannot be so readily prepared from dust not previously extracted, and which is much valued by farmers. The nitrogenous substance which has been extracted from the bone-dust with the glue, is sometimes substituted by horn, blood, or leather, to endeavor to give a product similar in composition to the original. It is of a finer grain than this, yet it is not generally considered equivalent to it. Such admixtures can be separated by shaking up the bone-dust with chloroform, their quantity and the amount of nitrogen can then be determined.—*Dr. R. Jones, Chem. Zeit.*



Fig. 1.—Common Salt.

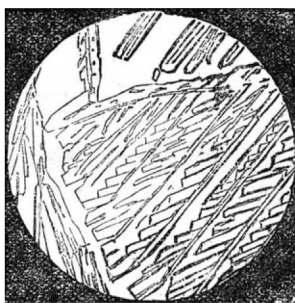

Fig. 2.—Potassium Nitrate.

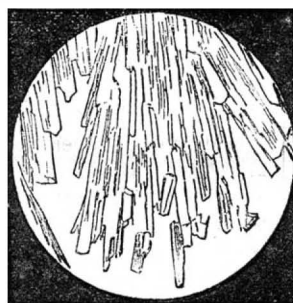

Fig. 3.—Oxalic Acid.

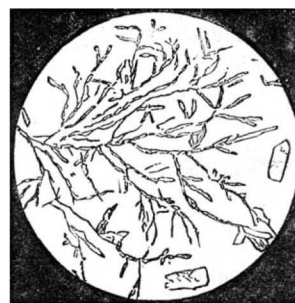

Fig. 4.—Potassium Dichromate.

gaining the glue (gelatin), but not to combine these two operations, as some works do. After the bones are steamed, they are brought into the oven or kiln. This need not have more than one story, and ought to be well ventilated. The further comminution of the dried bones is effected by wooden or iron pounders. The bones are now mostly reduced only to grout, and there are 3 to 4 degrees of grain obtained. It is therefore necessary to carefully mix the different sorts of dust, in order to prepare a product of the usually required composition, namely, 20 per cent phosphoric acid, and 4 per cent nitrogen. As iron, in the form of nails, etc., cannot entirely be removed before pounding and grinding, and as it would greatly damage the millstone, it is best to fix magnets at suitable spots. Animal charcoal is prepared either by burning the whole bones or the bone grout in closed spaces or vessels. Although the first method seems to have several advantages over the second one, it would only be profitable if the price of bones be extremely low. The burning of the ground bones was formerly almost exclusively done in iron pots, holding about 80 pounds, of which 80 to 100 were placed in an oven. The ammonia thereby formed was allowed to escape, but, more recently, the gases issuing from the oven were made to pass through a coke tower, and washed with sulphuric acid. This oven has recently been much improved, and will probably soon be replaced by the oven constructed by Sebor. Instead of using pots, Sebor burns the bones in iron cylinders of 3 to 4 meters in length, which can be opened at both ends to empty and recharge. The burning is finished in four to six hours. By condensing the escaping gases with water, the solution of ammonium carbonate, of up to 15° B., is obtained, also animal oil. The ovens, which contain a number of such cylinders, are heated by coal, recently also by gases from generators. A full third of the nitrogen contained in the grout is obtained as ammonium salt; dilute sulphuric acid, if used as absorbing liquid, would probably raise the yield considerably. The bone oil, which contains 9 to 10 per cent nitrogen, is best utilized by heating it with lime, and obtaining sulphate of ammonia. There was, and is perhaps still, a prejudice that the animal charcoal burnt in cylinders is inferior to that burnt in pots, on account of a coating of glossy carbon being more readily formed. This can, however, only be admitted in case of deficient management or a faulty ar-

Isolation in Contagious Diseases.

At a recent meeting of the Académie de Médecine, M. Hillairet read a report prepared in answer to a questions asked by the Minister of Public Instruction, regarding the length of time a pupil affected with any of the contagious diseases should remain separated from the other pupils. M. Hillairet's report may be summed up in the following propositions:

1st. Pupils suffering from varicella, smallpox, measles, mumps, or diphtheria should be completely isolated and hold absolutely no communication with the other members of the school. 2d. Isolation should continue forty days for smallpox, measles, scarlatina, and diphtheria; twenty-five days for varicella and mumps; the patient should have repeated baths before being allowed to join his comrades. 3d. The clothes worn by the patient at the time he fell sick should be submitted to a heat of 90° C., and then to repeated fumigations of sulphur. 4th. The bed clothes, curtains, carpets, furniture, and even the walls of the room occupied should be carefully disinfected, washed, and aired. 5th. If the pupil is taken sick at home he should not be allowed to return to school without the certificate of a physician attesting that all these precautions have been faithfully carried out.

Mica Face Masks.

It is reported that the mica face masks made by Herr Raphael, in Breslau, are proving very beneficial to workmen exposed to great heat, acid fumes, flying sparks, or fragments of stone or metal. The mica plates are fixed in metallic frames, protected with asbestos. The masks cover the eyes more effectively than mica spectacles do, and the whole face as well. The neck and shoulder may at the same time be protected by a fireproof cape of asbestos or other proper material. The space between the masks and the face allows the use of inner glasses for improving vision or shading the eyes. The tough and flexible mica prevents the breaking of the glasses by heat or flying fragments.

Oil of Peppermint in Neuralgia.

Dr. Meredith, in the *Birmingham Medical Review*, recommends oil of peppermint as an external application for allaying the neuralgic pain so often complained of in cases of *Herpes zoster*. He has used it with great relief to the patient even when the eruption was out in a fresh florid condition. He thinks that the value of this remedy in relieving neuralgic pain deserves to be better known.

RECENT INVENTIONS.

Improved Refrigerator.

The engraving shows a new refrigerator having the walls so constructed that the non-conducting material cannot be destroyed by moisture, and it is claimed that in this refrigerator considerably less ice will be required than in refrigerators of the usual construction. The walls, top, and bottom are made of three partitions, having paper placed between the outer and middle partitions, and having an air space formed between the middle and inner thicknesses. A smaller chamber is arranged within the refrigerating box and provided with a swinging top and bottom, which are opened automatically when the door of the small compartment is closed, and are closed automatically when this door is opened, so that the warm air of the room is prevented from passing into the large refrigerating box. This invention has been patented by Mr. Charles G. Wiesner, of 1507 Main street, Kansas City, Mo.

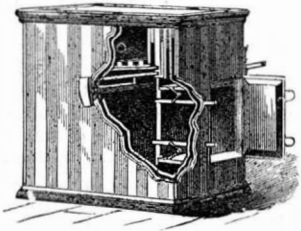

Earth Auger.

Messrs. Thomas Porter and George W. Gilliland, both of Abilene, Texas, have recently patented an earth auger, that requires but little power to operate it, and with which a hole can be bored in ordinary soil in much less time than with the common earth auger. Referring to the engraving, A is the shaft, having at its lower end radial arms, B, that are curved downwardly at their outer ends. To the arms, B, are attached the spring blades, C, having shanks that are bent to correspond with the curvature of the arms, B, and extending downward, and curved inward at the bottom to near the axis of the shaft. The shaft has an eye in upper end for inserting a sweep to turn the auger. In ordinary soil it is self-feeding, and requires but little pressure to start it in a hard soil. The earth which the blades cut loose is gathered in the blades, and held for raising out of the hole. The blades are adjustable on the arms for different sized holes. Further particulars may be obtained by addressing Thomas Porter, P. O. Box 24, Abilene, Texas.

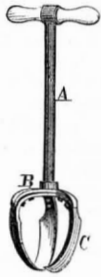

Adjustable Mop Holder.

An improved device for holding a mop, scraper, carpet stretcher, broom and brush handles, and other objects, has been patented by Mr. Isaac A. Rowell, of New Paris, Ind. Two shallow cups, one having a socket for attaching a handle, the other being enough smaller to set bottom up in the first, are each provided with ratchets in their inner surfaces, and are held to each other by a key that passes through the center of each of them, as shown in the engraving. A part of the rim of the outer cup is cut away, and to the inner cup is secured a pair of spring wire clamping jaws, provided with a slide to close them together to grip any object placed between them. By removing the key the parts can be so placed in relation to each other that the clamping device shall be at any desired angle with the handle, and they are secured in this position by replacing the key.



Blake's Improved Cultivator.

The implement shown in the engraving is a hand cultivator applicable to stirring up the soil between growing crops in gardens and other plots. The cultivator may be conveniently supported in front by a band or strap passing over the shoulders of the operator, and it may be readily guided and adjusted as to the depth to which it should work by simply pressing on handles attached to the beam as the operator draws the cultivator after him. By taking out one or more of the cranked cultivator teeth, of which there may be any desired number, the implement may be adjusted to work between rows of different widths. This is easily done by taking out the wedges which hold the teeth in place. A hand cultivator of this kind is cheaply made, and will thoroughly stir the soil, destroying all weeds, and leaving the soil in a smooth mellow condition. This invention has been patented by Mr. William Blake, of Chester, S. C.

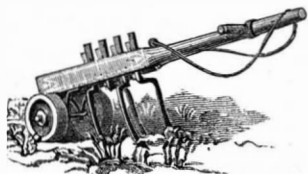

Improved Wrench.

We give a perspective and a detail view of a novel wrench recently patented by Mr. Henry Tregellas, of Delaware Mine, Mich. This is a combined nut and pipe wrench provided with a reversible jaw to adapt it to both nut and pipe work. The larger figure is a perspective view of the wrench, with its reversible jaw arranged to adapt the instrument as a nut wrench; and the smaller view is a partially sectional longitudinal view of the wrench with its reversible jaw adapted for a pipe wrench. The body of the wrench terminates at its lower end in a curved skeleton handle. The movable jaw is fitted to slide on the bar, and is adjustable thereon by means of a screw arranged to be turned by the thumb of the hand which holds the wrench. The screw projects through a slot in the jaw and engages with a spirally toothed hollow rack in the front side of the bar. This jaw has a recess in its back, in which is a spring. The spring holds the screw in gear with the rack. By throwing the screw out of engagement with the rack the jaw can be pushed forward or backward by the thumb to adjust it to its work, so that only a slight turn of the screw is afterward necessary to give the requisite grip. The same construction also provides for the rapid removal of the serrated jaw from the bar and over and off the skeleton handle. When the wrench is in use the harder the strain thrown upon the jaw the firmer will the screw engage with the rack. The tool can be very quickly changed from a nut wrench to a pipe wrench.

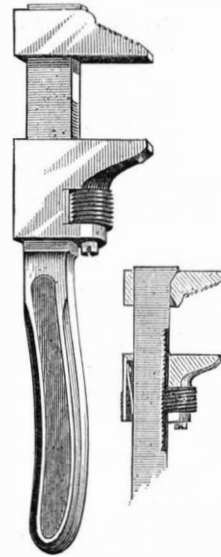

Slanker's Pruning Shears.

In the improved pruning shears shown in the engraving one of the shear blades is attached to a lever which ranges along the lever of the other shear blade, and is pivoted at the point of the blade to a lever, which is itself pivoted to the lever of other shear blade in about the position where shears are ordinarily pivoted, making an efficient compound lever arrangement, enabling the instrument to cut more powerfully than in the simple form. This useful invention has been patented by Mr. Frank O. Slanker, of Pomona, Cal.

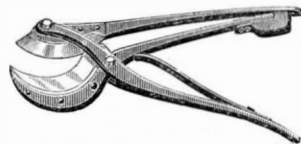

Improved Bench Plane.

The improvement consists in a stirrup pivoted to the sides of the plane in such a manner that the cross piece of the stirrup passes through a transverse groove in the under surface of the plane, this groove increasing in height toward the rear of the plane, so that when the plane is drawn backward it will be slightly raised by this stirrup, so that the cutting-edge of the plane iron cannot slide on the board being planed, the object being to prevent dulling the cutting-edge of a plane-iron by the backward movements of the plane. The upper figure of the engraving shows the position of the stirrup while the plane is being moved forward, and the lower figure shows the plane as lifted by the stirrup during its backward movement. This invention was recently patented by Mr. Geo. F. Sawyer, of Livingston, Tex.

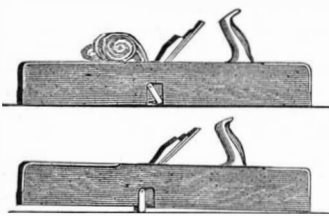

Improved Churn.

The invention shown in the annexed engraving consists in an internally serrated churn journaled in standards, and provided with an opening in one of the heads, closed by a cover held in place by a screw pintle passed through a cross piece on the inside of this head and through the cover, the cover being pressed against the head by a winged nut on the threaded pintle. The end of the threaded pintle is screwed into one end of the journaled handle shaft, which, when the pintle is screwed in the proper distance, is locked by means of a latch to prevent further longitudinal movement and to rotate the churn. There is a sliding supporting frame on the base of the churn for holding the

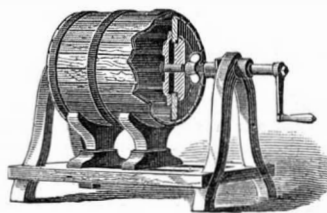

cream box during adjustment of the bearings. By rotating the churn by means of the crank the cream is quickly operated upon to release the oil globules, and the butter is produced with little exertion. This invention has been patented by M. Henry Hays, of Bridgeport, Cal.

Wages in American and English Shipyards.

In the building of iron ships the mechanics employed may be roughly divided into thirty-six classes, in five departments; in the shipyard department, fourteen classes; in the departments of steam engine and boiler building, seven each; in the iron and brass foundries, four grades each. The wages paid in these several departments here and in England are thus contrasted by *Our Continent*:

In the first department the highest wages paid go to the shipsmith, and the lowest to the rivet boys. In the United States the shipsmith receives per week \$15.95; in England \$6.65; the rivet boy here gets \$3.30; and abroad \$1.69. In the steam department the draughtsmen with us receive \$19.80; in England he has \$8.22. A helper in this department in this country gets \$8.80; in England and in Scotland \$3.87. In the boiler department in the United States a flange-turner gets \$16.50; the same man abroad gets \$6.20. A loam moulder in the iron foundry here gets \$16.50; in England \$6.50. Brass moulders with us receive \$14.30, and in England \$6.15. The total week's wages of thirty-six men in England would be \$192.60; while in the United States their wages would be \$406.01. In a shipyard, in good times, both here and in England, which might employ two thousand men, they would receive in that case with us \$22,540, and in England or on the Clyde only \$10,708.

A leading ship builder asserts that in the construction of iron ships ninety per cent of the total cost is for labor, applied first or last to the raw material as found in the mine or the forest. The difference in the actual cost of ships in the two countries, however, is not at all in proportion to the difference in rates of wages, owing chiefly to the larger use of machinery here, and the greater efficiency of the higher priced workmen.

The Bartholdi Statue of Liberty.

The inaction of the committee having in charge the work of soliciting subscriptions for the foundation and pedestal for Bartholdi's Statue of Liberty has led to some impatience on the part of the French Committee of Presentation. The rumor that the latter committee were contemplating an offer of the statue to Boston has stirred the New York committee a little; but they are still debating whether to attempt to raise the money by popular subscription or to solicit a few large contributions from the more wealthy citizens of the city. It is due to the artist and his friends that the inaction here should be speedily terminated. A member of the committee has said that various engineers have estimated the cost of a suitable base for the statue at from \$150,000 to \$1,000,000. It is thought that an acceptable base can be made for \$200,000. This sum is a mere trifle for the wealth of New York; and if the committee cannot raise it promptly they ought in courtesy to decline the proffered gift in favor of Boston or some other more deserving city. The statue is valued at about \$400,000.

The Hecker Mills Fire.

John V. Hecker, superintendent of Hecker's flour mills in this city, which were recently destroyed by fire, testified as follows before the Fire Marshal in the examination into the cause of the fire: "I believe that the fire originated in the Harris 'smutters' on the seventh floor, directly under the dustroom. 'Smutters' are generally considered the most dangerous parts of the machinery of a mill, on account of the friction which may be produced by any foreign substance getting in and striking fire between the revolving cylinder and the case surrounding it. These cylinders were of stone, and the casings were of chilled iron. The smutters make from 250 to 300 revolutions per minute. The dust is sucked from the smutters and forced by a fan into the dustroom, through a spout about ten inches square. I think the fire was caused by a spark, struck by friction in the smutters, igniting the dust, and passing through the spout into the dustroom, and igniting the dust therein. I have seen sparks fly from the smutters, and have found pieces of nails which have passed through the smutters."

Blasting by Means of Lime.

A trial of this new process of blasting in coal mines by means of quicklime, lately illustrated in the SCIENTIFIC AMERICAN, was made the other day in what is known as the Silkstone Colliery in England. A hole three inches in diameter and four feet deep was drilled in a solid mass of coal, and after clearing out, a perforated iron tube was first inserted, and then a charge of compressed quicklime, formed into a cartridge about three inches long. After forcing the cartridge into place and tamping the hole, water was pumped into the tube, and the coal immediately began to give way; and in thirty minutes a mass weighing about ten tons separated almost unbroken. The waste in dust and small coal was only six per cent, a much smaller proportion than is usual where powder is used for extraction, and the new process seems likely to become popular.

ENGINEERING INVENTIONS.

Messrs. Benjamin F. Tiffany, of Ionia, Mich., and Fred. M. Tiffany, of Aurora, Ill., have patented an improved manner of attaching brake shoes to the brake shoe head. The shoe has flanges at its ends, and a wing on one of its sides, that is adapted to be passed into a recess on the edge of the brake shoe head, the ends of the head passing under the flanges on the end of the shoe. The head has apertured lugs above and below the recess, through which a pin is passed for holding the shoe to the head.

Improvements in smoke burners for furnaces have been patented by Mr. James Johnson, of North La Crosse, Wis. The smoke burner consists of an elongated hood or half tube, that projects through and fills the top half of the doorway of the furnace and passes down into the fire box at an angle of about forty degrees. By this device the air is conducted down on to and among the burning fuel in the bottom of the fire box, consuming the smoke produced by the combustion of the fuel.

Mr. Francis J. Carney, of Brooklyn, N. Y., has patented an improved steam valve. The valve plug is threaded externally, and is provided with two or more side openings. The valve box is threaded internally, and is of such size that the valve plug screws into it. Suitable devices are provided for packing the valve stem. As the valve plug is never entirely removed from the port no foreign matter can enter between the sides of the plug and the port, and the valve remains tight.

Mr. John M. Taylor, of Frederickton, Can., has patented an improved window for locomotives, cars, steamboats, pilot-houses, etc. The window consists of a frame fitted with two sashes, glazed with glass or other transparent material, and a heating coil of pipe arranged between the glasses. The heating coil has an inlet and exhaust connection with the boiler, and keeps the window heated and free from ice and snow. Mr. Taylor has also patented a device to enable the engineer of a locomotive to see ahead clearly when the engine is enveloped in smoke and steam. A funnel-shaped pipe projects from the cab window, ahead of the smoke stack, sufficient to prevent the snow thrown up by the plow from obscuring the front. The front end is closed with a window, and the tube and window are heated by steam pipes connected with the boiler.

Improvements in balanced slide valves have been patented by John J. DeLancey, of Binghamton, N. Y. The valve is made hollow and rectangular in form, and between the valve and a face plate fitted in the upper part of the steam chest is a slotted balance plate. The upper edges of the valve are slotted to receive square packing bars, and beneath the bars are springs to hold them against the balance plate. In the sides of the valve are apertures for the admission of steam to the grooves. Suitable devices are provided for oiling and adjusting the parts.

Messrs. Leon Debarnot and Jules Jacquot, of Buenos Ayres, have patented improvements in the class of locomotives that have the boiler and the body of the tender hung below the wheel axles. The pivot joint that connects the engine and tender consists of two pairs of rigid plates, that mesh together in horizontal planes and are held by a vertical pin, and form the stoker's platform.

Mr. John Gates, of Portland, Ore., has patented improved devices for operating the valves of direct acting steam pumps. The steam and pump cylinders are of the usual construction, the connecting piston rod having the usual block for operating the valve mechanism, consisting of two parallel bars pivoted to and connected by upright bars pivoted near their centers on the frame of the pump. The lower parallel bar is provided with adjustable stop blocks, against which the blocks on the piston press to move the bars, and the upper bar is hinged to the valve stem. Novel devices are provided for reversing the engine and regulating the throw of the valve.

An automatic car brake, in which the power for operating the brake is obtained from the rotation of the car axle, has been patented by Mr. Benjamin F. Smith, of Alabaster, Mich. On one end of the car a slide buffer rod is fitted with spiral springs that keep it moved forward, and at the opposite end of the car the buffer rod is rigidly fixed. When the engine is reversed, the movable rod slides to operate devices that connect with the axle to drive sprocket wheels and chain that connect with a spur wheel on which is a winding drum that winds the brake chain to control the brakes.

Mr. Vernon C. Jarboe, of Wyandotte, Kan., has patented improvements upon the hoisting apparatus for which his application for letters patent was allowed him August 3, 1881. The shafts upon which the winding drum and power wheel are placed are journaled in the frame of the apparatus in line with each other. On the inner end of the shaft of the power wheel is a fixed clutch, and on the adjacent end of the winding shaft is a sliding clutch and a loose clutch cog wheel. With this construction the apparatus is easily adapted for speed or power in lifting.

A combined fish plate and nut lock has been patented by Mr. Daniel Faulkner, of Paris Cross ing, Ind. The inner fish plate is of the ordinary construction, and the outer is thicker and extends to the top of the rail, having on its lower edge a flange forming an acute angle with the plate. A key, beveled on its lower side to fit the angle, has on its upper side a series of recesses corresponding with the bolts in the rails, one of which is the form of an acute angle, the others being square. When the nuts of the rails are turned square the key is driven under locking them. The nut over the angular recess is turned to fit the angle, locking the key in its place.

Mr. John Milton, of Hamilton, Va., has patented improvements in the construction of railway cars by which the telescoping of cars is avoided. The diagonal corner of each end of the car is made independent of the frame timbers of the main structure, but is fastened to the same to fill out the outline of the car. If the cars are driven together with great force these parts are disconnected and the cars wedge past each other instead of telescoping.

Improvements in car couplings have been patented by Mr. William H. Swinford, of Cherokee, Ala. The drawhead and coupling pin are of the usual construction, the head of the coupling having an opening through which passes the inner end of a lever, that is pivoted to the end of the car and projects from its sides where it is provided with a crank. A chain attached to an arm on the lever is also attached to a U-shaped ball pivoted to the end of the car. When the lever is pressed down the pin is raised, and when it is turned the ball raises the link for coupling.

MECHANICAL INVENTIONS.

Messrs. Thomas A. Lewis and George W. Call, of Urbana, Ill., have patented improvements in two wheel cultivators. The cultivators are so constructed that they may be used with or without a tongue as the nature of the work may require. The wheels are so attached that they may diverge laterally to allow the axles and cultivator beams to maintain their proper relations to the beam of the cultivator. Devices are also provided for regulating the depth of the plows, and for raising the plows from the ground for transportation.

Mr. Joseph S. Cook, of Whitinsville, Mass., has patented improvements in mandrels for holding saws at an inclination for cutting grooves. Usually saws are fastened in this manner by the use of two beveled washers. With this mandrel four beveled washers are used, and the saw can be adjusted by these to any desired angle. To prevent the washers from turning on each other they are provided with notches and pins that enter the notches.

Mr. John E. Clement, of Peabody, Mass., has patented improvements relating to a machine shown in letters patent, No. 247,014, for whitening leather. The improvements consist in a novel arrangement of mechanism for rocking the cutter shaft, and also in devices by which the grinder shaft is reciprocated, to move the grinder back and forth from one side of the cutter head to the other. These devices simplify the machine and make its operation more perfect.

ELECTRICAL INVENTION.

Improvements in armatures for dynamo electric machines have been patented by Mr. Henry B. Sheridan, of Cleveland, O. The armature core is a hollow iron ring nearly square in its cross section, and is provided with ribs that cross its periphery, and their tapering ends are bent over and secured to the sides of the core. The helices are wound around the ribs and are held in place by plates secured by screws to the outer sides of the ribs. With this construction the greatest possible part of the helices is brought into the magnetic field.

TEXTILE INVENTION.

Mr. James A. Parr, of Lowell, Mass., has patented improvements upon the knitting machines, for which letters patent were granted to him, March 18, 1879. In these machines yarns of different colors are automatically manipulated for producing striped goods, and the improvements consist in devices by which the adjustment of the thread, guides, and other mechanism for moving the yarns in and out of action is facilitated, and also in mechanism by which the cut off ends of the yarn are made to appear on the wrong side of fabric only. Mr. Parr has also patented a pattern wheel having a plain portion upon which is secured a sufficient number of removable strips, to form a continuous plain surface of circular form. The plain surface may be broken at any point by removing one or more strips to give a greater variability of movement to the tappet lever for introducing or severing the different colored yarns in knitting horizontal stripes.

AGRICULTURAL INVENTIONS.

Improvements in riding attachments for plows have been patented by Mr. Charles H. Wance, of Lewisville, Ind. The plow is of the ordinary construction, and in front and rear of the plow standard are attached the ends of two bars that are connected near their inner and outer ends by crossbars, the whole forming the frame of the attachment. The frame is braced and secured to the clevis by a rod. The outer end of the frame is supported by a wheel, and by suitable devices the driver's weight is made to balance the plow and to cause it to plow deeper or shallower as is desired.

A machine for raking hay and loading it into a wagon has been patented by Mr. Otis D. Thompson, of Elkhart, Ind. The machine consists in a rake for collecting the hay, a revolving fork to carry it to an endless apron placed on a carrier frame, one end of which is at the rake and the other elevated above the wagon. These devices are attached to a sulky, and are driven by a sprocket wheel and chain from one of the sulky wheels. The carrier frame is adapted to be elevated and lowered from the driver's seat.

An apparatus adapted to sowing tobacco, cabbage, and other small seeds, has been patented by Mr. John F. Heady, of Ghent, Ky. The lower part of the seed box is cylindrical in form and the upper part vertical, and the ends are flanged caps that are secured in place by spring catches. The drive wheels are attached to an axle that passes through the center of the circular part of the seed box, and to which is attached a stirring reel to agitate the seed so that they will readily pass out through holes in the bottom of the seed box. A suitable handle is provided for moving the apparatus.

Messrs. Robert and Sidney T. Bruce, of Marshall, Mo., have patented a corn planter in which the seed dropping device is operated by a toothed metallic disk that is made to rotate through the plowed soil in contact with the hard ground underneath, avoiding the irregularity of the operation which results from driving in contact with the uneven surface of the soil. The dropping slide is operated by a crank shaft and pitman, driven by a pinion on the side of the disk.

Mr. John T. Cooper, of Somerville, Ala.,

has patented improvements in fertilizer distributors. A hopper is secured to the plow frame behind the plow, in which is a vertical shaft having at its lower end a tapering groove through which the fertilizer is distributed to the furrow. Devices are provided for raising and lowering the shaft to distribute more or less as desired. A cord passing around a pulley on the shaft is attached at its ends to the fore legs of the horse, the motion of the horse's legs rotating the shaft to prevent the fertilizer from clogging.

MISCELLANEOUS INVENTIONS.

A holder for supporting sacks of various sizes for the packing of wool has been patented by Mr. Julius Holekamp, of Comfort, Tex. The base of the holder is slotted radially to receive standards having tenons on their lower ends that fit the radial slots. A ring that is made adjustable to fit bags of different diameter is secured to the upper ends of the standards, by hooks that are held and guided in slots in the standards. By these devices the holder is adjustable to bags of any length or size.

An improvement in trucks used for handling boxes, barrels, etc., has been patented by Mr. Joseph J. Swain, of Montevallo, Ala. A cant hook is attached to the frame of the truck in such a manner that it can be engaged with the upper end of the barrel or box, to enable the operator to tilt the truck back and pull the load on to it by the application of both hands to the upper ends of the handles. The cant hook is adapted to be shifted up and down on the truck for the height of the package to be handled.

A device for extinguishing a fire as soon as it originates, and giving an alarm at the same time, has been patented by Mr. Clemens Kupka, of Phillipsburg, N. J. Water stand-pipes reach to the ceilings of the rooms, and arms attached to the cocks of the pipes are held raised by cords suspended from the ceiling by loops of inflammable material. When a fire breaks out the loops burn, the arms drop, and the water cocks are opened. The arms also operate a fire alarm.

An improved arrangement of the knives of the class of pulp beating engines in which an internal cone revolves in a conical case has been patented by Mr. John E. Warren, of Cumberland Mills, Me. On the inner surfaces of the case and cone are steel knives, divided in uniform lengths, so that each section of the cone works against the corresponding section of the case. The knives are adjustably secured to move out or in, or endwise, to take up any wear or for adjustment.

A novel device for supporting the doors of ticket cases, such as are used in railroad offices, has been patented by Mr. Melvin H. Tappan, of La Cygne, Kan. A lever is pivoted near the back of the case, having a pawl to engage with a ratchet pivoted to the side of the case. The brace that holds the door is pivoted to the end of the pawl lever. By these devices the door may be securely held at any desired height.

A head protector that is adapted to the use of bee keepers and as a protection against mosquitoes and other poisonous insects, has been patented by Mr. Robert W. Turner, of Kosse, Tex. The protector consists of a skeleton mask, made of thin strips of spring steel like that used in hoop skirts, and is to be covered with netting. The strips are secured to each other adjustably to adapt it to any sized head.

An improvement by which the tongues of vehicles are made so as to be quickly attached and detached, has been patented by Mr. John L. Metcalfe, of Waynesborough, Pa. To the rear end of the tongue a pintle rod is secured. A pair of hooks are secured to the axle in such a manner that the pintle rod may be dropped into the hooks, where they are retained by gravity latches, which move in a plane parallel with the axle, and prevent the rod from getting out of the hooks.

An improved clothes pounding washing machine has been patented by Mr. Joseph I. Dalbey, of Frankfort, Ind. The machine is adapted to be used on any ordinary washtub, and consists in a peculiar arrangement of a standard swinging bar and a lever, whereby a pounder connected to and operated by the lever may be moved up and down to pound the clothes, and carried in any direction to pound the clothes in any part of the tub.

Mr. Valentine Gilsinger, of Charleston, Ark., has patented improvements in wagon brakes. The improvements consist in the devices for applying and holding the brakes. Parallel curved ratchet bars are secured to the side of the wagon box, and between the bars a lever moves that is pivoted at its lower end, and has pivoted to it a lever upon which is hinged a wide pawl that engages with the teeth of both ratchet bars. The levers are so arranged that when the levers are both seized the pawl is raised, and by moving the lever the brake is applied.

Improvements in ventilators have been patented by Mr. Alexander B. Summers, of Brooklyn, N. Y. The usual cap covers the top of the ventilating shaft. A series of openings are arranged spirally one above another in the shaft, and uptakes are secured at the openings on the inner walls that cause any current of air entering the openings to be directed upward, causing a suction in the ventilator.

Mr. Thomas Atkinson, of Galena, Kan., has patented an improved provision safe. A casing covered with wire cloth, and made in two sections hinged to each other, is mounted loosely on a vertical shaft. The casing surrounds a series of brackets and shelves attached to a sleeve, also mounted upon the vertical shaft. With this construction the safe is easily taken down and can be closely packed for transportation.

An improvement in stoves and furnaces, by which the smoke, soot, and other products of combustion are consumed, has been patented by Mr. Abraham M. Wayne, of Quincy, Ill. A hot air chamber placed over the fire pot heats air that is deflected by a funnel shaped plate on to the surface of the fire in the pot, consuming the gases, smoke, and soot.

An improved stove cover lifter has been patented by Mr. William F. Shuter, of Manistee, Mich. The instrument is constructed in such a manner

that it is adapted to be used as a lifter for stove covers, pots, and bake pans, or plates, and as a tack puller and hammer, as a glazier's tool for setting window glass, and also as a can opener. The implement is cheap, durable, and adapted for all the purposes mentioned.

Improvements in the construction of watchmen's registers have been patented by Mr. Charles E. Sanford, of New York city. The object is to improve the register for which letters patent were granted to James Dunning, April 25, 1871, in such a manner that the marker will change its position automatically each day, and also so that the door of the register cannot be opened until the time for which it was set has expired.

A new flavoring extract to give sirups and sugars the flavor of maple has been patented by Mr. Josiah Daily, of Madison, Ind. The extract is a decoction of hickory bark, or wood, and may be added to any kind of sugar or sirups, producing a sirup that tastes very much like the genuine maple sirup.

Mr. William C. Allen, of West Union, O., has patented an improved wood sawing device for use with an ordinary hand saw buck. The saw is an arc of a circle, of which a pivot in the center of the top of the frame is the center. The frame is pivoted in a slot in a standard through which it swings and in which the frame is adapted to be raised and lowered. This device enables the operator to work the saw with both hands.

Mr. William H. Hall, of 242 East 23d street, New York city, has patented a combined horse collar and breast band, the breast band being attached to and extending down from the ends of the collar so as to fit tightly against the animal's breast, and is provided at its ends with trace buckles and loops, and near its top with terrets for the reins. The breast band is cut in such a manner that it inclines downward slightly from the ends of the collar, and fits close to the breast. It will not chafe or cut as a straight band does, and with this device the strain is distributed equally over the collar and the pad.

An oil can that will have a free flow of oil, and if upset will always be in a position to prevent the oil from flowing, has been patented by Mr. John Kaye, of Cardington, Pa. The nozzle of the can is arranged in an obtuse angle to the body, and directly opposite the mouth of the nozzle on the can is a counter balance weight that when the can is upset throws the nozzle up to prevent the escape of oil. To the filling cap is attached a tube that serves to admit air when the nozzle is turned downward.

Improvements in hay presses have been patented by Mr. George Ertel, of Quincy, Ill. The head against which the hay is pressed is in the upper part of a vertical chamber, in which a follower is worked up and down by means of a toggle lever, the lever being so arranged that it can swing each way. The follower is raised and carries up a portion of hay at every traverse of the lever. By suitable devices the hay is retained until the chamber is filled and firmly packed, the power of the lever increasing with the resistance to be overcome.

A device for more thoroughly and easily separating slate from coal has been patented by Mr. Fred. B. Parrish, of Wilkesbarre, Pa. The coal trough down which the coal passes has a transversely convex bottom by which the coal is fed and spread in thin layers on tables, at which the picker sits to pick out the slate as the coal is fed. The tables also have apertures through which the separated coal is dropped.

A simple and effective gate latch has been patented by Mr. Isaac Joyner, of Jonesborough, Miss. This latch consists of a forked bar of any elastic wood, secured at one end to the rear side of the gate in such a manner that the forks of the bar, when the gate is closed, shell engage in notches formed on both sides of a pointed head or catch secured in a proper position on the gate post.

A combined safety hook and buckle for harnesses has been patented by Mr. Francis A. Hake, of Cuero, Texas. The buckle is composed of a rectangular frame, in which a bar slides up and down, provided with small prongs for holding the strap that passes through the buckle frame. A hook made integral with one of the bars of the frame has a keeper that is placed in a slot made in the shank of the hook, and drop over the point to prevent the object placed in the hook from becoming detached.

An improved float for fishing lines has been patented by Mr. Oliver G. Wilson, of Gallatin, Tenn. The body of the float is made of suitable light material, and has a central opening through its length to receive a stem that projects above and below the body and is secured to it. Guide holes made in the ends of the stem pass out through the sides, and serve to produce friction on the line, and prevent the float from slipping when the line is suddenly jerked.

Improvements in the form and manner of attaching the springs to side bar buggies have been patented by Mr. William D. Ament, of Muscatine, Ia. The springs are attached to the side bars, by means of plates formed with a bent portion for receiving the bolt at the end of the spring. These plates are secured to the under side of the side bars by clips, and may be moved on the bars as may be desired. The springs are ogee shaped at the ends, and elevated in the center.

A hand power mechanism for working cross cut saws for sawing wood has been patented by Mr. Francis M. Elliott, of Summum, Ill. The driving gear is placed on upright posts secured to a bed sill a suitable distance above the ground to be conveniently worked. A beam projects from the posts, and has at its outer end a dog to be driven into the log to hold it. The beam is supported from the log, and carries the connecting devices by which the saw is moved.

A saddle-tree, especially adapted to the saddles used by stock drivers and for holding the lariat, has been patented by Mr. Theodore E. Meanea, of North Denver, Col. The saddle-tree is of the ordinary construction, except that there is a small upwardly projecting neck instead of the full sized horn. On this neck is secured casing having in its top a wooden cap that is secured with the casing to the saddle. In this way a cheap substantial horn is made.

Business and Personal.

The Charge for Insertion under this head is One Dollar a line for each insertion; about eight words to a line. Advertisements must be received at publication office as early as Thursday morning to appear in next issue.

Am. Twist Drill Co., Meredith, N. H., make Pat. Chuck Jaws, Emery Wheels, Grinders, automatic Knife Grinders.

The Chester Steel Castings Co., office 407 Library St., Philadelphia, Pa., can prove by 20,000 Crank Shafts and 15,000 Gear Wheels, now in use, the superiority of their Castings over all others. Circular and price list free.

Small articles in sheet or cast brass made on contract. Send models for estimates to H. C. Goodrich, 66 to 72 Ogden Place, Chicago, Ill. Mention this paper.

Pays well on small investment.—Stereopticons, Magic Lanterns, and Views illustrating every subject for public exhibitions. Lanterns for colleges, Sunday-schools, and home amusement. 116 page illustrated catalogue free. McAllister, Manufacturing Optician, 49 Nassau St., N. Y.

Calcium Light Apparatus and Stereopticons at low prices. C. Beseler, 218 Centre Street, New York.

Design Patent for Sale.—Handsome Hanging Vase. Address Mrs. Rose L. Allen, Romolo, Centre Co., Pa.

From Galveston City Railroad Co., Galveston, Sept. 22, 1882. To H. W. Johns M'fg Co., 87 Maiden Lane, N. Y.

Gentlemen: By mail of this date I send you photograph of our Beach Pavilion on which was used your Liquid Paints, and I am pleased to advise you that same have given perfect satisfaction.

Very respectfully, W. H. Sinclair, President. Paragon Drawing Paper is the only reliable. Send for samples. Keuffel & Esser, 127 Fulton St., New York.

Garmore's Artificial Ear Drums for relief of partial or entire deafness. Invented by one who has been deaf thirty years. Simple and scientific in construction; not observable in use. Send for circular. John Garmore, S. W. cor. 5th and Race Sts., Cincinnati, O.

American Fruit Drier. Free Pamphlet. See ad., p. 237. Fire Brick, Tile, and Clay Retorts, all shapes. Bornerg & O'Brien, M'Frs, 23d St., above Race, Phila., Pa.

Drop Forgings of Iron or Steel. See adv., page 236.

For best Portable Forges and Blacksmiths' Hand Blowers, address Buffalo Forge Co., Buffalo, N. Y.

Brass & Copper in sheets, wire & blanks. See ad. p. 236. The Improved Hydraulic Jacks, Punches, and Tube Expanders. R. Dudgeon, 24 Columbia St., New York.

Diamond Tools. J. Dickinson, 64 Nassau St., N. Y. Eagle Anvils, 10 cents per pound. Fully warranted.

Bostwick's Giant Riding Saw Machine, adv., page 238. Tight and Slack Barrel Machinery a specialty. John Greenwood & Co., Rochester, N. Y. See illus. adv. p. 236.

Pure Nickel Anodes, Nickel Salts, and all Polishers' Supplies. Greene, Tweed & Co., New York. For Mill Macby & Mill Furnishing, see illus. adv. p. 236.

See New American File Co.'s Advertisement, p. 238. Renshaw's Ratchet for Square and Taper Shank Drills. The Pratt & Whitney Co., Hartford, Conn.

Woodwork'g Mach'y. Rollstone Mach. Co. Adv., p. 238. Trevor's Patent Key Seat Cutter. Trevor & Co., Lockport, N. Y. See page 237.

Wanted.—Liberal inducements and facilities for locating large iron works. Address Iron, Manchester, N. H. Schools open.—Send for Catalogue of Drawing Materials. Keuffel & Esser, New York.

25' Lathes of the best design. G. A. Ohl & Co., East Newark, N. J.

50,000 Emerson's Hand Book of Saws. New Edition. Free. Address Emerson, Smith & Co., Beaver Falls, Pa.

Cope & Maxwell M'fg Co.'s Pump adv., page 220. The Berryman Feed Water Heater and Purifier and Feed Pump. L. B. Davis' Patent. See illus. adv., p. 220.

For Pat. Safety Elevators, Hoisting Engines, Friction Clutch Pulleys, Cut-off Coupling, see Frisbie's ad. p. 222. Red Jacket Adjustable Force Pump. See adv., p. 220.

Mineral Lands Prospected, Artesian Wells Bored, by Pa. Diamond Drill Co. Box 423, Pottsville, Pa. See p. 220. Common Sense Dry Kiln. Adapted to drying of all material where kiln, etc., drying houses are used. See p. 222.

4 to 40 H. P. Steam Engines. See adv. p. 220. Collection of Ornaments.—A book containing over 1,000 different designs, such as Crests, Coats of Arms, Vignettes, Scrolls, Corners, etc., will be mailed free on receipt of \$1. Address Palm & Fechteler, 6 West 14th Street, New York.

Drop Forgings. Billings & Spencer Co. See adv., p. 205. C. B. Rogers & Co., Norwich, Conn., Wood Working Machinery of every kind. See adv., page 205.

Lightning Screw Plates, Labor-saving Tools. p. 206. Engine, 10s to 50 horse power, complete, with governor, \$250 to \$550. Satisfaction guaranteed. Six hundred in use. For circular address Heald & Morris (Drawer 127), Baldwinville, N. Y.

Improved Skinner Portable Engines. Erie, Pa. Combination Roll and Rubber Co., 68 Warren street, N. Y. Wringer Rolls and Moulded Goods Specialties.

Pure Water furnished Cities, Paper Mills, Laundries, Steam Boilers, etc., by the Multifold System of the Newark Filtering Co., 177 Commerce St., Newark, N. J.

Latest Improved Diamond Drills. Send for circular to M. C. Bullock Mfg. Co., 80 to 88 Market St., Chicago, Ill.

First Class Engine Lathes, 20 inch swing, 8 foot bed, now ready. F. C. & A. E. Rowland, New Haven, Conn.

Ice Making Machines and Machines for Cooling Breweries, etc. Pictet Artificial Ice Co. (Limited), 142 Greenwich Street. P. O. Box 3083, New York city.

Jas. F. Hotchkiss, 84 John St., N. Y.: Send me your free book entitled "How to Keep Boilers Clean," containing useful information for steam users & engineers. (Forward above by postal or letter; mention this paper.)

Steel Stamps and Pattern Letters. The best made. J. F. W. Dorman, 21 German St., Baltimore. Catalogue free.

Rubber Hose, Linen Hose, lined and unlined, all sizes. Greene, Tweed & Co., 118 Chambers St., New York

For Power & Economy, Alcott's Turbine, Mt. Holly, N. J.

Presses, Dies, Tools for working Sheet Metals, etc. Fruit and other Can Tools. E. W. Bliss, Brooklyn, N. Y.

Supplement Catalogue.—Persons in pursuit of information on any special engineering, mechanical, or scientific subject, can have catalogue of contents of the SCIENTIFIC AMERICAN SUPPLEMENT sent to them free. The SUPPLEMENT contains lengthy articles embracing the whole range of engineering, mechanics, and physical science. Address Munn & Co., Publishers, New York.

Machinery for Light Manufacturing, on hand and built to order. E. E. Garvin & Co., 139 Center St., N. Y.

Wood-Working Machinery of Improved Design and Workmanship. Cordesman, Egan & Co., Cincinnati, O.

Presses & Dies. Ferracute Mach. Co., Bridgeton, N. J.

Presses & Dies (fruit cans) Ayar Mach. Wks., Salem, N. J.

Split Pulleys at low prices, and of same strength and appearance as Whole Pulleys. Yocom & Son's Shafting Works, Drinker St., Philadelphia, Pa.

Notes & Queries

HINTS TO CORRESPONDENTS.

No attention will be paid to communications unless accompanied with the full name and address of the writer.

Names and addresses of correspondents will not be given to inquirers.

We renew our request that correspondents, in referring to former answers or articles, will be kind enough to name the date of the paper and the page, or the number of the question.

Correspondents whose inquiries do not appear after a reasonable time should repeat them. If not then published, they may conclude that, for good reasons, the Editor declines them.

Persons desiring special information which is purely of a personal character, and not of general interest, should remit from \$1 to \$5, according to the subject, as we cannot be expected to spend time and labor to obtain such information without remuneration.

Any numbers of the SCIENTIFIC AMERICAN SUPPLEMENT referred to in these columns may be had at this office. Price 10 cents each.

Correspondents sending samples of minerals, etc., for examination, should be careful to distinctly mark or label their specimens so as to avoid error in their identification.

(1) J. G. M. writes: I have often heard said by men who run machinery (flour mills, for instance) by water power, that (as they express it) the water is heavier at night than in the daytime, and that they are obliged to let the water-gate down at night or else the machinery would run away. A. This question respecting water power has been carefully examined, and there appears to be no good ground for the assertion. 2. Blacksmiths also say that they can get a piece of iron to a welding heat quicker at night than at daytime. Will you please inform me through Notes and Queries if this is really so? A. This is also fallacious. It is an optical deception.

(2) G. C. C. writes: I have a double cylinder engine, 1 1/2 inch bore, 2 inch stroke, with a steam pressure of 100 pounds, and 400 to 500 revolutions per minute. How large a boat can I propel with it at a speed of six to seven miles per hour? A. Hardly large enough to carry one man to run the engine and move the vessel. 2. What diameter and pitch of wheel would I require for the engine and boat? A. Larger and more pitch than the engine would drive. If your boat is small enough to get the speed it would be little more than a large toy. A boat, say 10 or 12 feet long, and 3 or 3 1/2 feet beam, might be driven by this engine 4 1/2 or 5 miles per hour.

(3) W. writes: In SCIENTIFIC AMERICAN, No. 43, vol. xiv., first page, Fig. 15, there is a cut of polished bell. Will you state what size of wire should be used for magnet and what quantity, in length or weight? A. Use No. 34 silk insulated copper wire, and make the depth of the winding equal to the diameter of the iron core.

(4) J. L. W. asks: What is the name of the acid that is used in shell stores in polishing and cleaning large shells—is it silicic acid? A. Yes. Hydrochloric acid diluted with water is also much used to cleanse them.

(5) E. McD. writes: By mistake a piece of oiled silk was placed between the leaves of a book and remained there until the oil, thick and soft, had penetrated through several of the leaves. Please inform me how the oil can be removed or hardened without effacing the print. A. Press powdered Fuller's earth lightly upon the greasy spot and allow it to soak the oil out.

(6) J. O'K. sends the following receipt for whitewash: Lime slaked with a solution of salt in water, and then properly thinned with skim milk from which all the cream has been taken, makes a permanent whitewash for outdoor work, and, it is said, renders the wood incombustible. It is an excellent wash for preserving shingles and for all farm purposes. And asks: Do you know of a better one; or, at least, can you suggest something that is good and more easily obtained than "skim milk"? A. You will find a receipt for a better and cheaper whitewash on page 52, vol. xiv.

(7) T. J. R. asks: Can you give me any information in regard to a whistle that is blown by water pressure? A. Whistles must be blown by air or steam, or any gas under pressure. Any steam whistle will blow effectively with air under the same pressure that is usually used with steam. Whistles made upon the same principles as organ pipes blow at very low pressures. The water jet would maintain a constant pressure, and with an easy blowing whistle would, no doubt, answer your purpose. This is supposing that you have considerable head of water and plenty of it; and may be made by setting up a long pipe perpendicular upon a chamber for holding the air and allowing the

water to separate from it; and from the bottom of the box raise a siphon pipe three or four feet high to carry off the water and maintain the pressure. Into the top of the main pipe throw a jet of water as strong as possible. This jet carries the air down the tube under considerable pressure, and with everything properly proportioned will furnish from the chamber sufficient air to blow a whistle.

[OFFICIAL.]

INDEX OF INVENTIONS

FOR WHICH

Letters Patent of the United States were Granted in the Week Ending

September 19, 1882.

AND EACH BEARING THAT DATE.

[Those marked (r) are reissued patents.]

A printed copy of the specification and drawing of any patent in the annexed list, also of any patent issued since 1866, will be furnished from this office for 25 cents. In ordering please state the number and date of the patent desired and remit to Munn & Co., 261 Broadway, corner of Warren Street, New York city. We also furnish copies of patents granted prior to 1866; but at increased cost, as the specifications not being printed, must be copied by hand.

Table listing inventions with patent numbers and names of inventors. Includes items like Airbrake for railway cars, Air compressor valve, Auger blanks, Automatic elevator, Axle, car, Bag, Bale opener, Bale tie, Baling press, Bathing box, Bed bottom, Bed bottoms, Bed bottom spring, Bed bottom, spring, Bed frame, Bed spring, Bedstead, Bedstead or lounge, Bedstead, wardrobe, Bee smoking apparatus, Belting, Bit, Blanking box holder, Boiler, Boiler cleaner, Boiler furnace, Boilers of road engines, Bolt, Bolt heading machine, Boltina reel, Boot jack, Bottle, D. Lubin, Bottles, apparatus for packing or holding, Box, Box, J. L. Stuber, Box fastener, Brace, Brace to prevent rolling in beds or berths, Brackets, manufacturing, Brake, Brake shoe, Breast strap slide and hook, Bricks and tiles, ornamentation of, Bridge, J. Maish, Bridle bit for horses, Bridle bit machine, Brush, gun, B. S. Gladding, Brush, tooth, L. Chevallier, Buckle, J. Bills, Buckle and rein ring, neck strap, Buckle, harness, J. T. Stoll, Bush, roller, P. Brownley, Button, cuff, D. Lubin, Button fastener, C. Erlanger, Button fastener, G. W. Prentice, Buttonholes, forming, Loo Chew Fan, Cabinet, A. F. Potts, Can opener, W. E. Brock, Can opener, W. A. McFarlane, Candlestick and loading tool combined, miner's, C. P. Des Moineaux, Car brake, F. W. Strehlan, Car brake, electrical, Paul & Kampfe, Car coupling, J. Coup, Car coupling, W. J. Dawson, Car coupling, H. Menzemer, Car coupling, F. P. Stebbins, Car, hand, G. S. Sheffield, Car, railway wrecking, R. Hitchcock, Car, sleeping, W. H. Wigmore, Car, weighing and transfer, L. D. Richardson et al., Carriage top brace, C. E. Giebel, Carriage top standard, C. C. Egerton, Cart, dumping, J. H. Ferguson, Case, See Organ case. Watch-case, Cattle fastening and releasing device, J. D. Walters, Chain, carrier, P. F. Hodges, Chair, See Invalid reclining chair, Charts, projection of, E. R. Knorr, Churn, B. F. Aldridge, Churn power, J. Wilber, Chute, log, W. H. Barnum, Cigar lighter, G. Selden (r), Cleaner, See Boiler cleaner. Slate or blackboard cleaner, Clocks, bell striking apparatus for, J. D. William, Clutch, friction, E. J. Sterling, Cock, alcohol, C. C. Mulford, Cock, compression, R. H. Lecky, Coffee boiler, W. C. Salmon, Coffee or tea pot, J. B. Mabury, Coin detector, counterfeit, J. B. Atwater, Composite washer, J. S. Hoffecker, Corset busk and clasp, C. A. Adams, Cotton elevator, J. F. Jones, Counterstink and bit gauge, conical, E. H. Sutton, Countersink plug, I. Sharp, Coupling, See Car coupling. Thill coupling, Crane, traveling, H. Davies,

Table listing inventions with patent numbers and names of inventors. Includes items like Crank and crank fastening, Crank attachment, Cream, artificial, Culinary boiler, Culinary use, compound for, Cultivator, Cushion, Cutter, Cutting and punching press, Dental plugger, Desk, Digger, Disintegrating machine, Display stand, Door check, Door plate, letter box, Drawer pull, Dress shield, Electric circuit cut-out, Electric distribution and translation system, Electric lights and conductors, Electric machine, dynamo, Electric machine, dynamo or magneto, Electric machine regulator, Electric wire cables, conductor for underground, Elevator, Engine, Evaporating saccharine juices, Evaporator, Eye wash, Fare register, Faucet, Faucet and tap, Feathers for dusters, Feeding water to locomotive boilers, Fence barb, wire, Fence, barbed wire, Fence palings, machine for barbing, Fence post, Amrose & Cole, Fence wire with metal, process of and apparatus for coating barbed, Fences, machine for manufacturing, Figures in relief on various substances, production of, Filter and cooler, combined water, Filtering and purifying water in wells, Firearm, breech-loading, Firearm, breech-loading, W. Mason, Firearm, breech-loading, Scott & Baker, Firearm lock, breech-loading, Fire escape, Flour bolt or dresser, Flute, T. Bertelung, Fodder cutter, E. Wagoner, Foli wrapper, rolled, Fur bats, making, Furnace, See Boiler furnace. Heating furnace. Privy furnace, Furnaces, signaling and registering attachment for reversing, Furniture, G. F. Richardson, Gas burning device, Gas refining and steam power apparatus, Gas, utilization of by-products in the manufacture of coal, Gate, J. M. Decker, Gate, J. E. Little, Gearing, C. E. Albro, Generator, See Steam generator, Glass, guide for ruling or for aiding in cutting, Glue, etc., heater, S. Willershausen, Grain binder, J. F. Appleby, Grain binder attachment, Kemp & Ross, Grain cleaning apparatus, D. Best, Grain separator, J. B. Sullit, Grain separator and cleaner, D. Best, Grate attachment, J. J. Mitchell, Grinding mill, J. E. Holmes, Grinding mills, test plate for roller, Glycerine from the residuary waters resulting from the manufacture of soaps, extraction of, Hame, J. G. Eberhard, Hammer and screwdriver, claw, Hammer, power, A. Beaudry, Handle, See Plate and dish handle. Rubber covered handle. Rubber handle. Trunk handle. Wire reel handle, Harrow, D. Matteson, Harrow and corn planter, combined, Harvester, corn, S. C. Kenaga, Harvester, corn, Kenaga & Briggs, Harvester, wheel, V. M. Chafee, Harvesters, Sheaf dumper for self-binding, Hat or other head covering, Hay loader, C. Scafe, Hay or cotton press, J. A. Lanham, Hay rake, horse, Westcott & Conner, Hay stacker, I. N. Condra, Heater, See Glue, etc., heater, Heater or condenser, T. W. Duffy, Heating apparatus, J. Johnson, Heating furnace, J. J. Richardson, Hog scraping machine, R. C. Tompkins, Hoisting apparatus, W. B. Moore, Holder, See Blacking box holder. Music holder. Pencil holder. Second hand holder. Tag holder. Twine holder, Holder for bills or notes and collection items, Hook, See Mousing hook, Horse power machine, H. Smith, House, See Milk house, Ice slide, O. & W. Guthrie, Injector, M. D. Strickland, Inkstand, G. H. Henkel, Inkstand, Royce & Hafner, Instrument for treating piles, W. Wiltge,

Edwards's Works on the Steam Engine.

THE Practical Steam Engineer's Guide

In the Design, Construction, and Management of American Stationary, Portable, and Steam-Fire Engines, Steam Pumps, Boilers, Injectors, Governors, Indicators, Pistons, and Rings, Safety Valves and Steam Gauges. For the use of Engineers, Firemen, and Steam Users. By Emory Edwards, M.E. Illustrated by 119 engravings. Second Edition. In one volume. 12mo. 420 pages. Price \$2.50.

A Catechism OF THE Marine Steam Engine.

For the use of Engineers, Firemen, and Mechanics. A Practical Work for Practical Men. By Emory Edwards, M.E. Illustrated by 60 engravings, including examples of the most modern Engines. Third Edition, Enlarged and Revised. In one volume. 12mo. Price \$2.00.

Modern American Marine Engines, Boilers, and Screw Propellers.

Their Design and Construction, showing the Present Practice of the most Eminent Engineers and Marine Engine Builders in the United States, among others, Charles W. Copeland, Charles E. Emery, Robert H. Thurston, Thomas Main, Thomas Jackson, George H. Reynolds, William H. Huffman, H. L. Stellwagen, John Roach & Son, The Wm. Cramp & Sons Ship and Engine Building Co., The Harlan & Hollingsworth Co., The Pusey & Jones Co., H. A. Ramsay & Co., The Atlantic Iron Works, The Morgan Iron Works, The Herrschoff Manufacturing Co., E. C. & A. E. Rowland, Delamater Iron Works, The New York Safety Steam Power Co., The United States Bureau of Steam Engineering, etc. For the Use of Engineers, Draughtsmen, and Engineering Students. By Emory Edwards, M.E. Illustrated by 30 Large and Elaborate Plates of the most recent American Marine Engines, Boilers, and Screw Propellers. In one volume. Quarto. \$5.00.

The above, or any of our Practical and Scientific Books, sent free of postage, at publication price to any address in the world.

Our new and revised Catalogue of Practical and Scientific Books, 96 pages 8vo. together with our other Catalogues, the whole covering every branch of Technology, sent free, and free of postage, to any one in any part of the world who will send his address.

HENRY CAREY BAIRD & CO., Industrial Publishers, Booksellers, and Importers, 510 WALNUT ST., PHILADELPHIA, PA.

Advertisement for DYKE'S BEARD ELIXIR, showing a portrait of a man and text describing the product's benefits for facial hair.

Proposals for Dredging. Potomac River Improvement near Washington, D. C.

U. S. Engineer Office, 2136 Pennsylvania Avenue, WASHINGTON, D. C., September 27, 1882. SEALED PROPOSALS, in duplicate, for Dredging in the Potomac River, near Washington, D. C., will be received at this office until 11 A. M. on MONDAY, October 30, 1882, and opened immediately thereafter. The approximate amount of dredging is One Million Seven Hundred Thousand cubic yards. Blank forms on which proposals must be made, specifications, and any desired information can be had on application to this office. PETER C. HAINS, Major of Engineers.

Advertisement for NEW YORK STENCIL WORKS, featuring 'STEEL STAMPS' and 'STENCILS' for various uses.

WANTED.—A FIRST-CLASS BRASS Moulder capable of running Brass Foundry successfully. State wages, and address, with testimonials. THE ENSIGN M'FG CO., Huntington, West Va.

FOR SALE.—State and County Rights for a valuable Patent, by respectable parties, on a liberal commission. Address D., Box 189, Philipsburg, Centre Co., Pa.

Advertisement for LYON & HEALY, State & Monroe Sts., Chicago, featuring 'BAND CATALOGUE' and musical instruments.

Free An Illustrated book and 12 elegant Chromo Advertising cards. Send your address and a three-cent stamp to the Acina Card Co., 104 Fulton St., New York. P. O. Box 2724.

AGENTS Wanted for handsome illustrated standard works of character; great variety; low in price; selling fast; needed in all parts. Bradley, Garretson & Co., 55 N. Fourth St., Philadelphia, Pa.

Advertisement for GOLD PENS, featuring 'The CALLI-GRAPHIC Pen' and 'MABIE, TODD & BARD'.

CLARK'S RUBBER WHEELS. This Wheel is unrivaled for durability, simplicity, and cheapness. Adapted for Warehouse and Platform Trucks, Scales, Heavy Casters, and all purposes for which Wheels are used. Circular and Price List free. GEO. P. CLARK, Windsor Locks, Ct.

FREE—Send your address, with two 3-cent stamps, to CHAS. FARRELL, 152 West 28th St., New York, and receive an elegant set of imported cards, together with our new illustrated book and card price list.

Advertisement for SEND TO LONDON BERRY & ORTON, PHILA PA FOR THE BEST BAND SAW BLADE.

WHEELER'S PATENT WOOD FILLER Fills the pores of wood perfectly, so that smooth finish is obtained with one coat of varnish. Send for circular.

SILICATE PAINTS. Most durable in the market. Sold in Paste, only needing thinning with Raw Oil or Turpentine, one gallon producing TWO GALLONS OF PAINT. Send for sample card of colors. BRIDGEPORT FINISHING CO., 40 Bleecker Street, New York.

Chicago, June 8, 1882. We are MORE THAN SATISFIED with our Pictet Refrigerating Machines, and consider them THE BEST IN THE MARKET. We have two of the largest size in full operation. YOUR attention is called to above certificate. ARMOUR & CO. THE PICTET ARTIFICIAL ICE CO., Limited, 142 Greenwich Street, New York. P. O. Box 3083.

Advertisement for MAGIC LANTERNS AND VIEWS ORGANS \$5. HARBACH ORGANINA CO., 809 FILBERT STREET, PHILADELPHIA, PA.

LANDRETH'S PEDIGREE SEEDS. For the Merchant on our New Plan SEEDS For the Market Gardener SEEDS For the Private Family SEEDS Handsome Illustrated Catalogue and Rural Register free to all. Merchants, send us your business cards for trade list. DAVID LANDRETH & SONS, SEED GROWERS, PHILADELPHIA, PA.

Edwin Alden & Bro.'s Advertising Agency. We own and control over \$200,000 worth of Advertising Space in the best Newspapers in the United States. Estimates and Special Lists sent free on application. Our American Newspaper Catalogue, 725 pages bound in cloth, sent prepaid for \$1.50. Address 5th and Vine Streets, Cincinnati, or 150 Nassau Street, New York.

Advertisement for MOSS ENGRAVING COMPANY, THE LARGEST ESTABLISHMENT OF THE KIND IN THE WORLD. SUPERIOR TO ANY OTHER METHOD. ENGRAVINGS FOR BOOKS, CATALOGUES, &c. THIRTEEN YEARS PRACTICAL EXPERIENCE.

RUPTURE cured without an operation or the injury trusses inflict by Dr. J. A. SHERMAN'S method. Office, 251 Broadway, New York. His book, with Photographic likenesses of bad cases, before and after cure, mailed for 10c.

Advertisement for BIBB'S FIRE-PLACE HEATERS. Celebrated Original BALTIMORE FIRE-PLACE HEATERS. To warm upper and lower rooms. The handsomest, most economical Coal Stoves in the world. B. C. BIBB & SON, Foundry, Office and Salesrooms, 39 and 41 1/2th Street, Baltimore, Md. MARBLIZED SLATS MANTELS. Send for Circulars.

50 Large, New Style Chromo Cards, no 2 alike, with name, 10c.; 6 pks. 50c. O. A. Brainard, Higganum, Ct. \$88 A week to Agents. \$10 OUTFIT FREE. RIDEOUT & CO., 10 BARCLAY ST., NEW YORK.

Advertisement for The Westinghouse Machine Company. Will make Special Contracts Speed Machinery, to THE WESTING CORRESPONDENCE Send for illus. The Westinghouse Works at Pittsburg, Pa. 92 & 94 LIBERTY STREET, NEW YORK.

SPEAKING TELEPHONES. THE AMERICAN BELL TELEPHONE COMPANY, W. H. FORBES President, W. R. DRIVER, Theo. N. VAIL, Treasurer, Gen. Manager. Alexander Graham Bell's patent of March 7, 1876, owned by this company, covers every form of apparatus, including Microphones or Carbon Telephones, in which the voice of the speaker causes electric undulations corresponding to the words spoken, and which articulations produce similar articulate sounds at the receiver. The Commissioner of Patents and the U. S. Circuit Court have decided this to be the true meaning of his claim; the validity of the patent has been sustained in the Circuit on final hearing in a contested case, and many injunctions and final decrees have been obtained on them. This company also owns and controls all the other telephonic inventions of Bell, Edison, Berliner, Gray, Blake, Phelps, Watson, and others. (Descriptive catalogues forwarded on application.) Telephones for Private Line, Club, and Social systems can be procured directly or through the authorized agents of the company. All telephones obtained except from this company, or its authorized licensees, are infringements, and the makers, sellers, and users will be proceeded against. Information furnished upon application. Address all communications to the AMERICAN BELL TELEPHONE COMPANY, 95 Milk Street, Boston, Mass.

WATCHMAKERS. Before buying lathes, see the "Whitcomb," made by AMERICAN WATCH TOOL CO., Waltham, Mass. \$66 a week in your own town. Terms and \$5 outfit free. Address H. HALLETT & Co., Portland, Me.

Advertisement for KEMP'S MANURE SPREADER, PULVERIZER and CART COMBINED. Greatest Agricultural invention of the age. Saves 50 per cent. of labor, and doubles the value of the manure. Spreads evenly all kinds of manure broadcast or in drill, in one-tenth the time required by hand. Send for Illustrated Catalogue and full particulars to KEMP & BURPEE M'FG CO., Syracuse, Onondago Co., N. Y.

TELEPHONE Latest, Best, Patented. Wire. Illus. Cir's free. Holcomb & Co., Cleveland, O. \$5 to \$20 per day at home. Samples worth \$5 free. Address STINSON & Co., Portland, Me.

Advertisement for RUBBER BACK SQUARE PACKING. BEST IN THE WORLD. For Packing the Piston Rods and Valve Stems of Steam Engines and Pumps. B represents that part of the packing which, when in use, is in contact with the Piston Rod. A, the elastic back, which keeps the part B against the rod with sufficient pressure to be steam-tight, and yet creates but little friction. This Packing is made in lengths of about 20 feet, and of all sizes from 1/4 to 2 inches square. JOHN H. CHEEVER, Treas. NEW YORK BELTING & PACKING CO., 29 Park Row, New York. SPECIAL NOTICE.—Owing to the recent great fire in the "World" Building, our office has been removed as above.

"BLAKE'S CHALLENGE" ROCK BREAKER. Patented November 18, 1879. For Macadam Roadmaking, Ballasting of Railroads, Crushing Ores, use of Iron Furnaces, etc. Rapidly superseding our older styles of Blake Crusher on account of its superior strength, efficiency, and simplicity. Adopted by important Railway and Mining Corporations, Cities, and Towns. First Class Medal of Superiority awarded by American Institute, 1879 and 1880. BLAKE CRUSHER CO., Sole Makers, New Haven, Conn.

CHARLES CHURCHILL & CO., 21 Cross Street, Finsbury, London, E. C., England. NEW YORK OFFICE, 495 GREENWICH ST. We have been introducing American Machinery and Tools in Great Britain, the British Colonies, and the European Continent since 1862, and are the agents of many of the largest American manufacturers. Having extensive facilities and connections, we are prepared to introduce new goods, especially in the line of Machinists' and Woodworking Tools and Machinery, and would invite manufacturers to confer with our New York office, where full information will be given.

Advertisement for ROOT'S NEW IRON BLOWER. POSITIVE BLAST. IRON REVOLVERS, PERFECTLY BALANCED, Has Fewer Parts than any other Blower. P. H. & F. M. ROOTS, Manufacturers, CONNERSVILLE, IND. S. S. TOWNSEND, Gen. Agt., 6 Cortland St., 8 Day St., COOKE & CO., Selling Agts., 3 Cortland Street, JAS. BRIGGS & CO., Selling Agts., 8 Day Street, NEW YORK. SEND FOR PRICED CATALOGUE.

BEATTY'S ORGANS, 27 stops, \$125. Pianos, \$297.50. Factory running day & night. Catalogue free. Address Daniel F. Beatty, Washington, N. J.

THE BIGGEST THING OUT. Illustrated Book sent free (new). E. NASON & Co., 111 Nassau St., New York.

Advertisement for THE RIDER COMPRESSION PUMPING ENGINE. (Hot Air), for city or country residences where it is required to raise a supply of water, is the most Perfect Pumping Machine in the market. Its marvelous Simplicity, absolute Safety, great Economy and Effectiveness, render it far superior to all others. Can be run by any inexperienced person. Send for catalogue and price list to CAMMEYER & SAYER, 33 Liberty St., New York, and 20 W. Lake St., Chicago, Ill. Please mention this Paper.

THE PORTER-ALLEN High Speed Steam Engine. ADDRESS SOUTHWARK FOUNDRY & MACHINE CO., 430 Washington Ave., Philadelphia, Pa.

An engine that works without Boiler. Always ready to be started and to give at once full power. SAFETY, ECONOMY, CONVENIENCE. Burns common Gas and Air. No steam, no coal, no ashes, no fire, no danger, no extra insurance. Almost no attendance. THE NEW OTTO SILENT GAS ENGINE. Useful for all work of small stationary steam engine. Built in sizes of 2, 4, and 7 H. P. by SCHIFFRICH & CO., N. Y. Cor. 384 & Walnut Sts. Phila., Pa. A. C. Manning, 38 Dey St., New York, Agent.

PAYNE'S AUTOMATIC ENGINES. Established 1840. Spark Arrester. Reliable, durable, and economical. Will furnish a horse power with one-third less fuel and water than any other engine built not fitted with an automatic cut-off. Send for Illustrated Catalogue "A" 2, for information and prices. B. W. PAYNE & SONS, Box 1207, Corning, N. Y.

Advertisement for MALLEABLE CASTINGS FROM SPECIAL THOMAS' FINE TUNING JAPANNING AND FINISHING. LEHIGH AVE. & AMERICAN ST. PHILA.

MACHINERY of every description. 121 Chambers and 108 Reade Sts., New York. THE GEORGE PLACE MACHINERY AGENCY.

NUT TAPPING MACHINE. DURELL'S PATENT. No. 1 Machine, 900 lb., 7 spindles. "2" "600" "8" Capacity of 7 Spindles, 8,000 per 10 hours. Acknowledged to be an indispensable tool Manufactured by HOWARD BROS., Fredonia, N. Y.

FOR A COMBINED Punch and Shears of beautiful design, of great strength and capacity, and thoroughly reliable, address Lambertville Iron Works, LAMBERTVILLE, N. J.

SHEPARD'S CELEBRATED \$60 Screw Cutting Foot Lathe. Foot and Power Lathes, Drill Presses, Scrolls, Saw Attachments, Chucks, Mandrels, Twist Drills, Dogs, Calipers, "An Light" Gas Machines, etc. Send for catalogue of outfits for amateurs or artisans. Address H. L. SHEPARD & CO., 341 & 343 West Front St. Cincinnati, O.

THE DUPLEX INJECTOR. The constantly increasing demand for this Boiler Feeder proves its superiority over other machines now in use. Send for illustrated circular and price list. Manufactured by JAMES JENKINS, Detroit, Mich.

Advertisement for TAPS & DIES, VISES, MACHINISTS' TOOLS, LATHES, FILES, STEEL STUBS.

TOOLS for Machinists, Carpenters, Amateurs, Jewellers, Model Makers, Blacksmiths, etc. Send for Catalogue, and state what kind of Tools you require. TALLMAN & McFADDEN, 607 Market St., Philadelphia, Pa.

Advertisements.

Inside Page, each insertion - - - 75 cents a line.
Back Page, each insertion - - - \$1.00 a line.
(About eight words to a line.)

Engravings may head advertisements at the same rate per line, by measurement, as the letter press. Advertisements must be received at publication office as early as Thursday morning to appear in next issue.

SMALL STEAM ENGINES.

We build seven sizes, from two to nine horse power; both vertical and horizontal, adapted to the needs of machinists, printers, laundrymen, dairymen, or farmers.

These Engines are suitable for any purpose requiring cheap and reliable power. Our prices are exceptionally low. Send for free illustrated price list.

Chas. P. Willard & Co.,
20 LA SALLE ST.,
CHICAGO, ILL.

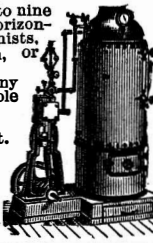

Sixteen Machinery Wiping Towels will be sent, post-paid, on receipt of \$1. Brown M'F'g Co., Providence, R. I.

THE QUEBER WATCH CASE

H.W. JOHNS' ASBESTOS

ASBESTOS STEAM PACKING,
ASBESTOS WICK PACKING,
ASBESTOS FLAT PACKING,
ASBESTOS SHEATHINGS,
ASBESTOS GASKETS,
ASBESTOS BUILDING FELT.
Made of strictly pure Asbestos.
PRICES REDUCED.
H. W. JOHNS M'F'G CO.,
87 Maiden Lane, New York,
Sole Manufacturers of H. W. Johns' Genuine
ASBESTOS LIQUID PAINTS, ROOF
PAINTS, ROOFING, STEAM PIPE
AND BOILER COVERINGS,
CEMENT'S, ETC.
Descriptive price lists and samples free.

Diamonds & Carbon

For all kinds of Mechanical Purposes.
Carbon for Mining Drills
A SPECIALTY.
Best quality at the lowest price.
The Oldest Established House in the U. S.
J. DICKINSON,
64 Nassau Street,
NEW YORK.

CATARRH.
On receipt of \$2 will send receipt. Will cure or give permanent relief. Ingredients in all drug stores.
Address J. BOWERS, Brookville, Ogle Co., Ill.



Stevens' Roller Mills,
FOR
GRADUAL REDUCTION OF GRAIN.
Manufactured exclusively by
THE JOHN T. NOYE MFG. CO., Buffalo, N. Y.

ROCK DRILLS & AIR COMPRESSORS.
INGERSOLL ROCK DRILL CO.,
1 PARK PLACE NEW YORK

MACHINISTS' TOOLS.
NEW AND IMPROVED PATTERNS.
Send for new illustrated catalogue.
Lathes, Planers, Drills, &c.
NEW HAVEN MANUFACTURING CO.,
New Haven, Conn.

CELEBRATED
WOOD WORKING MACHINERY.
IRON TOOLS,
ENGINES & SUPPLIES.
H.B. SMITH MACHINERY CO.
CORRESPOND WITH 925 MARKET ST. PHILADELPHIA PA U.S.A.
AVAIL YOURSELF OF OUR LARGE STOCK

ERICSSON'S
New Caloric Pumping Engine
FOR
DWELLINGS AND COUNTRY SEATS.
Simplest, cheapest, and most economical pumping engine for domestic purposes. Any servant girl can operate. Absolutely safe. Send for circulars and price lists.

DELAMATER IRON WORKS
C. H. DELAMATER & CO., Proprietors,
No. 10 Cortlandt Street, New York, N. Y.

SHAFTS PULLEYS HANGERS
At Low Prices. Large Assorted Stock.
A. & F. BROWN, 43 Park Place, New York.

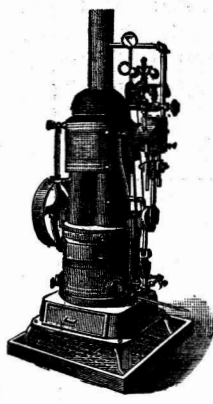

ESTABLISHED 1844.
J. C. TODD,
ENGINEER AND MACHINIST.

Flax, Hemp, Jute, Rope, Oakum, and Bagging Machinery, Steam Engines, Boilers, etc. Sole agent for Mayher's New Patent Acme Steam Engine and Force Pump combined. Also owner and exclusive manufacturer of

The New Baxter Patent Portable Steam Engine.

These engines are admirably adapted to all kinds of light power for driving printing presses, pumping water, sawing wood, grinding coffee, ginning cotton, and all kinds of agricultural and mechanical purposes, and are furnished at the following low prices:

- | | |
|----------------------|--------------------------|
| 1 Horse Power, \$150 | 1 1/2 Horse Power, \$190 |
| 2 Horse Power, 245 | 2 1/2 Horse Power, 275 |
| 3 Horse Power, 290 | 4 Horse Power, 350 |

Send for descriptive circular. Address

J. C. TODD, Paterson, N. J.,
Or No. 10 Barclay St., New York.

TELESCOPES Microscopes, Opera Glasses, Spectacles, Barometers, Thermometers, and Compasses. R. & B. BECK, Manufacturing Opticians, Philadelphia, Pa. Send for Illustrated Priced Catalogue.

60 INCH SWING DRILL
EXTRA HEAVY STRONG AND POWERFUL
SUITABLE FOR BOILER MAKERS H. BICKFORD
SEND FOR PHOTO. CINCINNATI, OHIO.

ROOFING.

For steep or flat roofs. Applied by ordinary workmen at one-third the cost of tin. Circulars and samples free. Agents Wanted. T. NEW, 82 John Street, New York.

BARREL, KEG, HOGSHEAD, AND Fan and Stave Jointer.
Chamfering, Howeling, and Crozing.
Stave Machinery.
Over 50 varieties manufactured by
E. & B. HOLMES,
Buffalo, N. Y. Head Rounding.
Truss Hoop Driving.

Double Screw Parallel, Leg Vises.
Muds and WARRANTED stronger than any other Vise by FISHER & NORRIS only, Trenton, N. J.

The "MONITOR."
A NEW LIFTING AND NON-LIFTING INJECTOR.

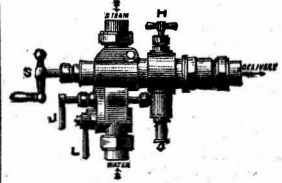

NATHAN & DREYFUS,
Send for catalogue. 92 & 94 Liberty St., New York.

Best Boiler Feeder in the world. Greatest Range yet obtained. Does not Break under Sudden Changes of Steam Pressure.

Also Patent **EJECTORS** OR

Water Elevators, For Conveying Water and Liquid. Patent Oilers, Lubricators, etc.

Pyrometers. For showing heat of Boiler Flues, Superheated Steam, Oil Stills, etc. **HENRY W. BULKLEY, Sole Manufacturer,** 149 Broadway, New York.

COLUMBIA Bicycles.

Thousands in daily use by doctors, lawyers, ministers, editors, merchants, etc. etc. Send \$2 stamp for elegantly illustrated 32 page catalogue to
THE POPE M'F'G CO.,
597 Washington Street, Boston, Mass.

Working Models
And Experimental Machinery, Metal or Wood, made to order by
J. F. WERNER, 62 Centre St., N. Y.

JOHN HARPER BONNELL PRESIDENT
A. RICHMOND HART VICE PRESIDENT
RUSSELL H. ROOT TREASURER

PHOTO ENGRAVING CO.
67-71 PARK PLACE, NEW YORK.

BRANCHES:
180 DEARBORN ST., CHICAGO
723 CHESTNUT ST., PHILADELPHIA

ENGRAVING FOR ALL PURPOSES.

VERTICAL ENGINES
THE BEST IN THE MARKET AT REASONABLE PRICES
MANUFACTURED BY
PHOENIX FOUNDRY MACH. CO.
SYRACUSE, N.Y.

THE J. L. MOTT IRON WORKS,
88 and 90 Beekman St., New York.
Demarest's Patent Water Closets used almost exclusively in all fine work. Demarest's Water Closets, Latrine's and Hopper's for public buildings and factories. Mott's Celebrated Porcelain Lined Baths unequalled for beauty and cleanliness. Sanitary Goods of all kinds.

WILLIAMS' PORT
Pony or Panel Planer. For general use in Door Shops, Box and Furniture Manufacturing. For planing Door Panels, Cigar Box Stuff, and Furniture work, it has no equal. We use the Ellis Patent three part Journal Box and a solid forged steel head. Has strong feed. Will plane from 1-16 to 6 inch thick. Weight, 1,400 lb. The lowest priced first-class planer in the market. ROWLEY & HERMANCO, Williamsport, Pa.

WM. A. HARRIS.
PROVIDENCE, R. I. (PARK STREET),
Six minutes walk West from station
Original and Only builder of the
HARRIS-CORLISS ENGINE
With Harris' Patented Improvements,
from 10 to 1,000 H. P.

SAWS 40,000 SAWS
EMERSON'S ILLUSTRATED SAWYERS HAND BOOKS (FREE) TO ANY PART OF THE WORLD.
EMERSON, SMITH & CO. BEAVER FALLS, PA.
5 CENTS EACH

WIRE ROPE:
THE HAZARD MANUFACTURING CO.
CHARLES PARRISH PRESIDENT.

TOOPE'S PATENT
Asbestos Lined Removable Covering,
Made of Felt and Asbestos. For use on STEAM BOILERS and PIPES, Refrigerators, Meat Cars, Ice Houses, and HOT and COLD WATER PIPES. Easily applied by any one.
Address **CHALMERS SPENCE CO.,** 23 John St., New York.

JENKINS PATENT PACKING
THE STANDARD
MAKES A PERFECT JOINT
JENKINS BROS. 71 JOHN ST. N.Y.

FOR LEARNING TELEGRAPHY
Or for operating short lines of Telegraph, get **The Morse Learner's Outfit**, price \$3.75. Complete full size Sounder, Key, Battery, etc. Our Illustrated Telegraph Catalogue, 32 pages, or Student's Manual of Instruction in Telegraphy, sent free by mail to any address.
J. H. BUNNELL & CO., 112 Liberty St., New York.

WIRE ROPE
Address **JOHN A. ROEBLING'S SONS, Manufacturers,** Trenton, N. J., or 117 Liberty Street, New York. Wheels and Rope for conveying power long distances. Send for circular.

EMPIRE FORGES
Improved without Belts, Bellows, Crank Pins, Dead Centers, or Back Motion. Send for circular.
EMPIRE PORTABLE FORGE CO., COHOES, N. Y.

PATENT QUICK SHAPERS
Adjustable Stroke
Can be Changed while in Motion.
E. GOULD & EBERHARDT, NEWARK, N. J.

MANUFACTURERS OF
WIRE ROPE, BRIDGE CABLES, SHIP RIGGING,
Tramway Ropes, Champion Barbed Wire, etc.
Office and Works: Wilkesbarré, Pa. Office and Warehouse: 87 LIBERTY ST., NEW YORK.

Engineering, Physics, Chemistry.

SWARTHMORE COLLEGE.
Thorough courses of study in new buildings erected for the purpose, with fully equipped laboratories, lecture and draughting rooms, each planned with special reference to its intended use. Latest and best apparatus, machinery, tools, etc. Experienced and painstaking instructors. Usual degrees. Also Classical and Literary courses of study and a course for Teachers. Ten miles from Philadelphia by rail. Charges moderate. Care of Friends. For full particulars, address **EDWARD H. MAGILL, A.M.,** of the Professors, or **EDWARD H. MAGILL, A.M.,** President, SWARTHMORE COLLEGE, SWARTHMORE, Pa.

KORTING UNIVERSAL

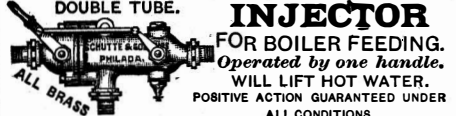

DOUBLE TUBE. INJECTOR
FOR BOILER FEEDING.
Operated by one handle.
WILL LIFT HOT WATER.
POSITIVE ACTION GUARANTEED UNDER ALL CONDITIONS.

NO ADJUSTMENT FOR VARYING STEAM PRESSURE.
WILL LIFT WATER 25 FEET. SEND FOR DESCRIPTIVE CIRCULAR.
OFFICES AND WAREHOUSES:
PHILADA., 12TH & THOMPSON STS. NEW YORK, 109 LIBERTY ST.
BOSTON, 7 OLIVER ST. CHICAGO, 84 MARKET ST.
AUGUSTA, GA., 1028 FENWICK ST. ST. LOUIS, MO., 709 MARKET ST.
DENVER, COLO., 194 FIFTEENTH ST. SAN FRANCISCO, 2 CALIFORNIA ST.
RICHMOND, VA., 1419 MAIN ST.

HARTFORD STEAM BOILER
Inspection & Insurance
COMPANY.

W. B. FRANKLIN, V. Pres't. J. M. ALLEN, Pres't.
J. B. PIERCE, Sec'y.

ELECTRIC LIGHT TELEPHONE & TELEGRAPH SUPPLIES
WALLACE DIAMOND
TRADE MARK
THE ELECTRICAL SUPPLY CO. 109 LIBERTY ST. NEW YORK

"LAFARGE" PORTLAND CEMENT.
"BURHAM" English PORTLAND CEMENT.
"KEENE" CEMENT (Coarse and Superfine).
These celebrated makes of imported cements for sale by **JAMES BRAND & Beekman St., New York.**

PROSPECTUS

OF THE
Scientific American
FOR 1882.

The Most Popular Scientific Paper in the World.
Only \$3.20 a Year, including postage. Weekly. 52 Numbers a Year.

This widely circulated and splendidly illustrated paper is published weekly. Every number contains sixteen pages of useful information, and a large number of original engravings of new inventions and discoveries, representing Engineering Works, Steam Machinery, New Inventions, Novelties in Mechanics, Manufactures, Chemistry, Electricity, Telegraphy, Photography, Architecture, Agriculture, Horticulture, Natural History, etc.

All Classes of Readers find in the SCIENTIFIC AMERICAN a popular résumé of the best scientific information of the day; and it is the aim of the publishers to present it in an attractive form, avoiding as much as possible abstruse terms. To every intelligent mind, this journal affords a constant supply of instructive reading. It is promotive of knowledge and progress in every community where it circulates.

Terms of Subscription.—One copy of the SCIENTIFIC AMERICAN will be sent for one year—52 numbers—postage prepaid, to any subscriber in the United States or Canada, on receipt of three dollars and twenty cents by the publishers; six months, \$1.60; three months, \$1.00.

Clubs.—One extra copy of the SCIENTIFIC AMERICAN will be supplied gratis for every club of five subscribers at \$3.20 each; additional copies at same proportionate rate.

One copy of the SCIENTIFIC AMERICAN and one copy of the SCIENTIFIC AMERICAN SUPPLEMENT will be sent for one year, postage prepaid, to any subscriber in the United States or Canada, on receipt of seven dollars by the publishers.

The safest way to remit is by Postal Order, Draft, or Express. Money carefully placed inside of envelopes, securely sealed, and correctly addressed, seldom goes astray, but is at the sender's risk. Address all letters and make all orders, drafts, etc., payable to

MUNN & CO.,
261 Broadway, New York.

To Foreign Subscribers.—Under the facilities of the Postal Union, the SCIENTIFIC AMERICAN is now sent by post direct from New York, with regularity, to subscribers in Great Britain, India, Australia, and all other British colonies; to France, Austria, Belgium, Germany, Russia, and all other European States; Japan, Brazil, Mexico, and all States of Central and South America. Terms, when sent to foreign countries, Canada excepted, \$4. gold, for SCIENTIFIC AMERICAN, one year; \$9. gold, for both SCIENTIFIC AMERICAN and SUPPLEMENT for one year. This includes postage, which we pay. Remit by postal order or draft to order of

MUNN & CO., 261 Broadway, New York.

PRINTING INKS.
THE "Scientific American" is printed with CHAS. ENEU JOHNSON & CO'S INK. Tenth and Lombard Sts. Phila., and 47 Rose St., opp. Duane St., N. Y.