

SCIENTIFIC AMERICAN

A WEEKLY JOURNAL OF PRACTICAL INFORMATION, ART, SCIENCE, MECHANICS, CHEMISTRY, AND MANUFACTURES.

Vol. XXXVI.--No. 5.
[NEW SERIES.]

NEW YORK, FEBRUARY 3, 1877.

[\$3.20 per Annum.
[POSTAGE PREPAID.]

THE GORILLA.

The gorilla is the largest of the anthropoid apes; and since his discovery in 1847, by Dr. T. S. Savage, he has attracted much attention from naturalists. The writings of Du Chaillu have done much to familiarize us with this remarkable animal; and its strength, ferocity, and cunning have made it remarkable, even in these days of natural wonders. The gorilla is chiefly found on the west coast of Africa, both north and south of the equator. It is generally seen in troops of four females and one male; and these never associate with other animals. The muscular power of the gorilla is prodigious. He marches steadily towards his enemy, beating his breast with both hands and roaring terribly; when near enough, he springs upon him, and destroys him by tearing him to pieces. One of Du Chaillu's men was eviscerated by a single blow from the paw of a gorilla.

In the dense forests of the African continent, man can only advance with difficulty; and the miasma that pervades them is sooner or later fatal to mankind. But here the gorilla takes up his abode, and his long arms and prehensile toes enable him to swing himself over long distances between the trees, and thus to wander over large tracts of country, passing each night in a rudely constructed nest made for the purpose.

Some of the antics of the gorilla are amusing, and resemble certain human characteristics to a remarkable degree. Mr. A. R. Wallace had one in Borneo; and when he gave it a piece of food to its liking, it licked its lips, drew in its cheeks, and turned up its eyes with an expression of supreme satisfaction. If it disliked a morsel, it would roll it round on its tongue, and then push it out between its lips. If it could not get the food it desired, it would scream like a baby in a passion.

The specimen shown in our engraving, in his sagacious watchfulness against strangers, is at once on the alert on the approach of a strange footstep; and the intruder who will face such a sentinel must be either very ignorant or very incautious. The picture is so vivid and life-like that it seems almost like a portrait taken on the spot; it is the work of Mr. Joseph Wolf, the eminent naturalist and artist, whose book, "The Life and Habits of Wild Animals," we have heretofore had occasion to notice.

A New Wall Paper.

It is now proposed in Germany to make wall paper which will adapt itself to the degree of illumination of the room, becoming darker as the room is more lit up, and *vice versa*. The *Papier Zeitung* suggests to this end paper printed or coated with oxalate of copper, which acts in the manner above described. It is believed that very curious and novel effects of color and shade may in this way be produced on wall papers, and possibly on other materials.

Manganese.

Messrs. Hobbs, Pope & Co., of Boston, Mass., state that the rumored discovery of a mine of pure manganese in Georgia is probably erroneous. They say: It is well known that nearly every State in the Union produces manganese to a greater or less extent, as well as all the provinces of the Dominion of Canada. The mines of England, Saxony, Spain, and Turkey mainly supply the European markets with ore. Manganese of high test and superior quality is obtainable only in limited quantities; while the medium and lower grades of ore, which are obtainable in almost any desired

Late Theories on the Earth's State.

Is the inside of the earth fluid or solid? Even in such an apparently simple question as this we are still in some degree of doubt. You may think this is strange, because we find volcanoes throwing out lava, which is liquid rock, and because we find much other geological evidence to show that solid rocks, such as basalt and trap, have been protruded as molten masses within recent geological epochs; but it has recently been shown by Mr. Mallet that the fact of volcanoes throwing out liquid rock may not be inconsistent with the view that the earth as a whole is solid. Mr. Mallet's investigations go

to prove that this liquefaction of the rocks which we observed may be produced at no very great depth from the earth's surface by the shifting and rubbing together of the rocks, owing to cracking due to the alteration of the temperature, just as boys at school rub a button on the bench until it is hot, when they often place it on to their neighbor's cheek. Applying the laws of the mechanical theory of heat to this problem, Mr. Mallet believes that the friction of the rocks, caused by the secular cooling of the earth and the consequent shrinkage, is a sufficient and a satisfactory explanation of the occurrence of the high temperature of volcanic action.

Sir Wm. Thomson, also, than whom no one is more capable of expressing an opinion, decides in favor of the earth's solidity. He tells us in his address to the Physical Section at Glasgow, that the conclusion concerning the solidity of the earth originally arrived at by Hopkins is borne out by a more rigorous mathematical treatment than this physicist was able to apply; so that the idea of geologists, who were in the habit of explaining underground heat, ancient upheavals, or modern volcanoes by the existence of a comparatively thin solid shell resting on an interior liquid mass, must now be given up as untenable.—*Professor Roscoe.*

A New Ornamental Panel.

Mr. William Bleiss, of New York city, has patented through the Scientific Patent Agency, December 5, 1875, a very tasteful frame or tile for decorative purposes, which he prepares from a glass plate having a roughened or crystallized surface, on

the back of which the design is traced in suitable colors to represent the seams between the pieces composing a mosaic. Transparent colors are then laid over portions of the work, and gold leaf is laid over the entire surface of the glass, and a backing added, which is composed of any material that will protect the surface and form a durable coating. The effect is very handsome; and as the paint will not crack or blister, the panel may be used in place of encaustic or other tiles for the exterior ornamentation of buildings.

THE head of a bolt is usually about twice the diameter of the spindle, and of a thickness which is generally greater than five eighths of that diameter.—*Rankine.*

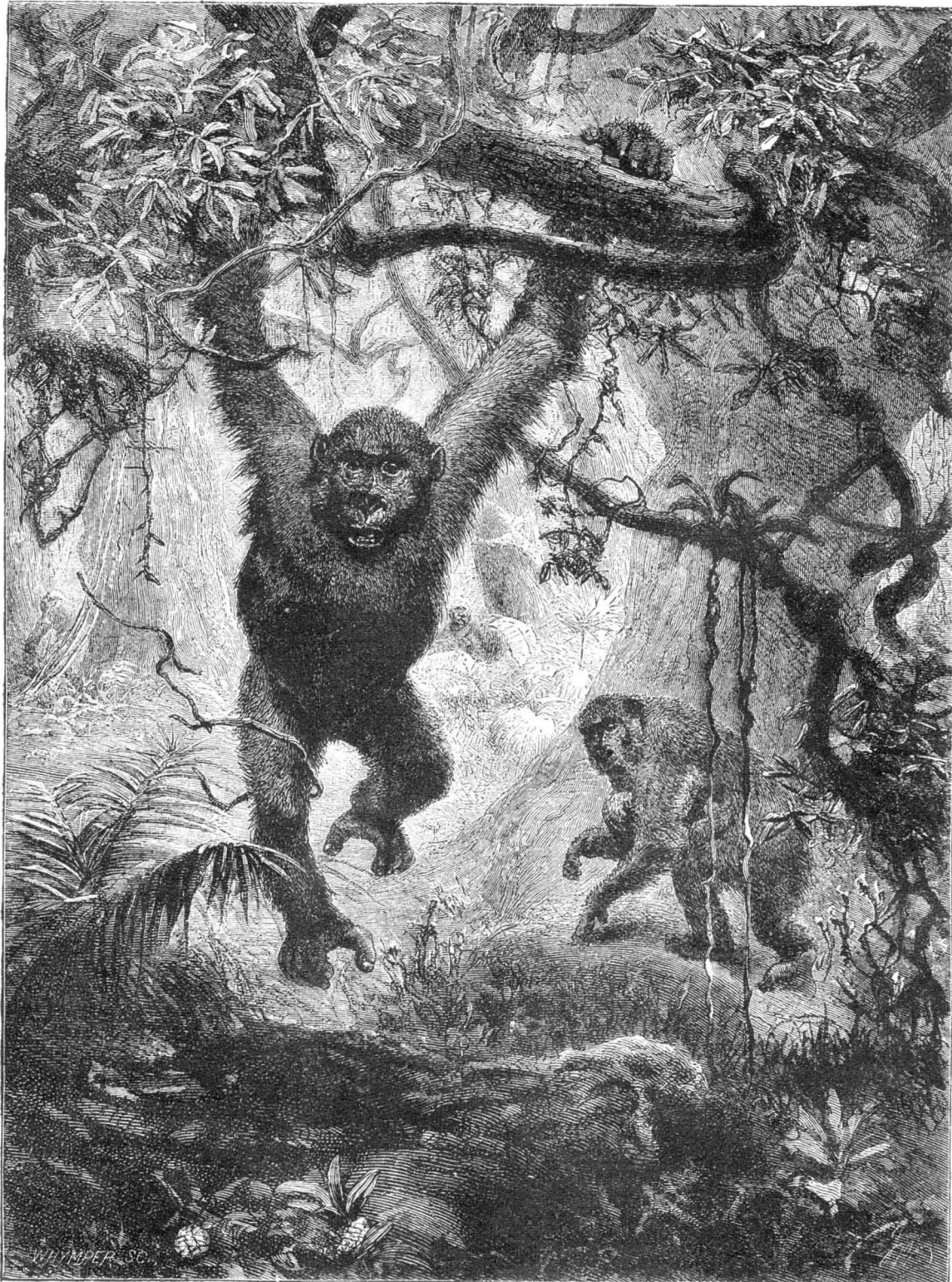

WHO COMES HERE?

quantity, will often not pay to ship. It is found in inexhaustible beds, like coal; but its deposits are very unreliable, it being almost always found in pockets, or in veins or seams, which can never be relied upon as carrying ore for any specified distance; it is, in fact, next to impossible to estimate the yield of a manganese mine for a specified time.

NOVEL CAVALRY EQUIPMENT.—It is intended to supply slabs of gun cotton as part of the cavalry equipment, to be carried in a sort of waist belt, and used, if necessary, for the destruction of railways, stockades, etc., for which purposes gun cotton has proved the most powerful of all explosive agencies, while it is the safest and most convenient to carry.

Scientific American.

ESTABLISHED 1845.

MUNN & CO., Editors and Proprietors.

PUBLISHED WEEKLY AT NO. 37 PARK ROW, NEW YORK.

O. D. MUNN. A. E. BEACH.

TERMS FOR THE SCIENTIFIC AMERICAN.

One copy, one year, postage included. \$3 20
One copy, six months, postage included. 1 60

Clubs.—One extra copy of THE SCIENTIFIC AMERICAN will be supplied gratis for every club of five subscribers at \$3.20 each; additional copies at same proportionate rate. Postage prepaid.

The Scientific American Supplement

is a distinct paper from the SCIENTIFIC AMERICAN. THE SUPPLEMENT is issued weekly; every number contains 16 octavo pages, with handsome cover, uniform in size with SCIENTIFIC AMERICAN. Terms of subscription for SUPPLEMENT, \$5.00 a year, postage paid, to subscribers. Single copies 10 cents. Sold by all news dealers throughout the country.

Combined Rates.—THE SCIENTIFIC AMERICAN AND SUPPLEMENT will be sent for one year, postage free, on receipt of seven dollars. Both papers to one address or different addresses, as desired.

The safest way to remit is by draft, postal order, or registered letter.

Address MUNN & CO., 37 Park Row, N. Y.

Subscriptions received and single copies of either paper sold by all the news agents.

VOL. XXXVI., No. 5. [NEW SERIES.] Thirty-second Year.

NEW YORK, SATURDAY, FEBRUARY 3, 1877.

Contents.

(Illustrated articles are marked with an asterisk.)

Academy of Sciences, New York. 67
Air, pressure and volume of (7). 75
Alloys, copper color on (17). 75
American beef in England. 72
Analysis. 72
Animals, the migrations of. 51
Answers to correspondents. 75
Antique inscription, an. 66
Astronomical notes. 73
Bay rum, oil of (8). 75
Boiler explosions. 73
Boiler scale preventive. 73
Bolts, proportions of. 68
Books, keeping. 65
Bridge, cost of the East river. 70
Business and personal. 75
Cast iron, painting. 73
Cattle food. 73
Cavalry equipment, novel. 68
Chemical magic*. 71
Chemical progress in 1876. 72
Chilblains, cure for (13). 75
Circle problem, the three (6). 75
Colds, the avoidance of. 72
Diamond, analysis of the. 72
Disinfectants. 73
Dyeing calf skins (11). 75
Earth's state, theories on the. 66
Editor, wants to be an. 68
Electric belts (14). 75
Engine, compound. 66
Ferruginous oxide in silicates. 67
Gas, making coal (21). 75
Glycerin, uses of. 69
Gold, six tons of. 65
Gorilla, the*. 63
Greek, finding an ancient. 75
Gun, recoil of a (1). 66
Hints, a few modest. 71
Hippopotamus dentistry. 67
Hop extract (9). 75
Hydrofluoric acid. 67
Hydroscopes, natural*. 67
Ideation in the. 63
Ink, blue, from gunpowder (12). 75
Insanity, encouragement of. 65
Iron from its sulphate (10). 75
Island, a sinking. 71
Laboratory notes. 67
Manganese. 67
Manufactures, diversity of. 71
Milk testing in Holland. 74
Mineral, a new. 67
Mind reading and conjurers. 64
New books and publications. 74
Nutriment in butter, etc., (3). 73
Oxyhydrogen gas machine (18). 75
Painting woodwork. 71
Panel, new ornamental. 63
Patent litigation, codfish. 65
Patents, delay in issue of. 65
Patents, American and foreign. 74
Patents, official lists of. 75
Pieric acid and hydrocarbons. 67
Polar expeditions, future. 64
Practical mechanism—No. 19*. 69
Prickly comfrey, the*. 71
Railroad bridges. 68
Railway accident, the recent. 68
Rollers, crushing force of (3). 75
Roots, respiration of*. 70
Rubber bath tub, cracks in (4). 75
Sand and water. 71
Solar phenomenon, a (22). 75
Soldering fluid (16). 75
Spark arrester, locomotive*. 69
Steamboats, early Mississippi. 68
Steamer, new food*. 67
Symphytum asperinum*. 71
Trees, buy small. 70
Trees, wash for. 68
Tube expander, new*. 68
Underground railway, London. 70
Valve gear (2). 75
Varnish for ink drawings (10). 75
Varnish for patterns (5). 75
Violins, woods, etc., for (18). 75
Wall paper, a new. 63
Worms, worms in (20). 73
Who comes here?*. 65

TABLE OF CONTENTS OF THE SCIENTIFIC AMERICAN SUPPLEMENT, No. 57.

For the Week ending February 3, 1877.

- I. MECHANICS AND ENGINEERING.—The Howe Truss Bridge, lately destroyed at Ashtabula, Ohio, 1 engraving.—Iron Railway Cars. Interesting Discussion of the subject by the Car Builders' Association.—Address by O. CHANUTE, C. E.—Iron Passenger Cars in France.—The Great Mexican Railway.—Korting's Locomotive Injector, 2 figures.—Hartnell's Governor, 1 engraving.—Elastic Washers, 2 figs.—New Blow-pipe.—The River Clyde. Interesting description of the engineering works by which the river was deepened and made navigable for large vessels, between Glasgow and the sea.—Concrete as a Building Material.—New Concrete Bridge.—Wind at 153 miles an hour.—Edgerton's Self-Acting Tidal Pier, for rise and fall of high tides, 5 engravings.—Progress of the Great Suspension Bridge between New York and Brooklyn, 1 engraving. Report of the Chief Engineer.—Proposed new Bridge, London.—Machinery of the new U. S. Sloops of War, 4 engravings.
II. TECHNOLOGY.—History of the Art of Coach Building.—An interesting lecture before the Society of Arts, by G. A. THURPE, with particulars of the construction of the most ancient vehicles.—Preserving Timber by the process of S. Beer.—Pelouze and Audouin's Apparatus for the Mechanical Condensation of liquids in gases, 4 engravings.—A new and remarkable Gas Burner of simple form, yielding heat of 3,000° F.—Vertical Retorts for distilling Shale and other Minerals, 4 figures.—New Bronze Salyr.—Mining and Metallurgy in the U. S.—Gonslock Bonanzas.—Casting Steel.—The Secor Process for Iron and Steel.—Sand in Iron.—Glauber's Salt as used in Wool.—Methyl Green on Wool.—Cachou de Laval as a color.—Uses of Walnut Peels for Dyeing.—Power Loom.—Preservation of Wood by salt.
III. ELECTRICITY, LIGHT, HEAT, ETC.—Researches on the Radiometer, by Prof. P. VOLPICELLI.—Recent Radiometer Experiments, by Prof. CROOKES.—Telegraphing without Wires; Gott's practical experiments.—Meeting of the Society of Telegraph Engineers.—Sir William Thompson's New Marine Compass.—Brief descriptions of various interesting Electrical Appliances, as exhibited to the Society.—The Siphon Telegraph Recorder.
IV. CHEMISTRY AND METALLURGY.—Palladium in the Alcohol Flame.—On Anthracene Testing, by R. LUCAS.—On the Artificial Coloring Matters derived from Coal Tar, by Prof. ADOLPH WURTZ, with 2 engravings; being an interesting and valuable description of the methods of producing the various coal tar colors; full of useful information.—Action of Water on Glass.—Spontaneous Combustion of Zinc.
V. ASTRONOMY, METEOROLOGY, ETC.—Meeting of the Royal Society.—Irradiation in Telescopes.—Spectrum of Vega.—Block Drop, Transit of Venus.—Photometric Observations of Venus.—Remarkable Binary Star.—Volcanic Ocean Distribution.
VI. AGRICULTURE, HORTICULTURE, ETC.—On the Growth of Plants, by W. B. HEMSLEY; an interesting and excellent paper.—Practical Directions for the Propagation of Grape Vines.—Five valuable rules for the successful Culture and Management of Grape Vines.

Terms:—SCIENTIFIC AMERICAN SUPPLEMENT, one year, postpaid, five dollars. One copy of SCIENTIFIC AMERICAN and one copy of SCIENTIFIC AMERICAN SUPPLEMENT, one year, postpaid, seven dollars. CLUBS.—One extra copy of the SUPPLEMENT will be supplied gratis for every club of five SUPPLEMENT subscribers at \$5.00 each.

All the back numbers of the SUPPLEMENT, from the commencement, January 1, 1876, can be had. Price 10 cents each.

NOW READY.—THE SCIENTIFIC AMERICAN SUPPLEMENT for 1876. Complete in two large volumes. Over 800 quarto pages; over 2,000 engravings. Embracing History of the Centennial Exhibition. New Illustrated Instructions in Mechanical Drawing. Many valuable papers, etc. Price five dollars for the two volumes, stitched in paper; or six dollars and fifty cents, handsomely bound in stiff covers.

Remit by postal order. Address

MUNN & CO., PUBLISHERS, 37 Park Row, New York.

Single copies of any desired number of the SUPPLEMENT sent to any address on receipt of 10 cents.

SOME SUGGESTIONS FOR FUTURE POLAR EXPEDITIONS

Of the numerous suggestions for reaching the north pole, which the failure of the recent English expedition to attain that goal has elicited, there are two which, apparently more than any of the others, have attracted public attention. The first is that, to cross the palæocrystic sea, which, by reason of its very irregular surface, Captain Nares pronounces impassible by any known means of sledge or like conveyance, balloons may possibly be utilized. The second contemplates the establishment of an arctic station, at as high a latitude as may be practicable, which shall serve as a basis of operations by a party who shall there take up a permanent residence until the object of the enterprise is accomplished. It is expected that, by this last plan, men can be acclimated, so to speak, to the intense cold, the absence of light for long periods, the deprivation of vegetable food, and other hardships of the polar regions; and they may be thus rendered less likely to be baffled by obstacles which have determined the failure of most previous expeditions. A project substantially similar to this is, we understand, already before Congress; and an appropriation of \$50,000, and the ordering of government officers and vessels to the duty is proposed.

The objections urged against the balloon project are, first, that the natural phenomena of cold, etc., would probably act upon the gas, or the envelope material of the air ship, and determine conditions unfavorable to its continued buoyancy; and secondly that, as balloons cannot be steered, the voyagers might find themselves carried anywhere but in the right direction; and that, in case of the balloon failing and compelling their descent far away from their base of supplies, their perishing would be a certainty. We allude to this plan simply because it is open to modification in a manner which we shall point out further on. We have first to suggest a possible improvement on the fixed station scheme.

We do not see the necessity of educating a band of men to dwell under adverse conditions as proposed, when the most that will be required, of all but the leaders, is physical work and endurance; and most especially when the people already fitted by nature for arctic life are at hand on the spot. In other words, we think that it would be much more practicable to engage a number of Esquimaux, bring them South, and educate them up to a point equal to that of the working white men, who would be otherwise employed as pioneers, hunters, sledge haulers, etc. We would teach them the object of the enterprise, and place them under the officers—of course white men—who would furnish the brains, and under whose government the work would be conducted.

It may be argued that the Esquimaux cannot be taught properly to serve the interests of such an expedition. Experience shows to the contrary. They are an intelligent people, and there is not an arctic explorer but can testify to the material aid which they have rendered. Hall and others who have dwelt among them state that they are quick to learn; and as an instance, Hall mentions that he found no difficulty in teaching them the intricate game of chess. They are the only people that can live in the land of no wood. Peschel, in his new work on "The Races of Man," says: "They have found out how to build huts of snow as quickly as tropical natives build them of branches and leaves: nay, they have constructed arched vaults of stone, which had not occurred to any of the civilized people of Mexico." The same authority, summing up their achievements, tells how they warm their huts with train oil lamps, how they invented sledges, and utilized the dog as a draught animal: "while in America, the most advanced stage of such art was to be found only among the Incas of Peru, who used llamas as beasts of burden, though not as draught animals." "Like assistants in the darkness," adds Peschel, "appear beings of our species whose cheerfulness is unaffected by cold and obscurity, and who contentedly wander and range over regions in which Nature seems armed with all the horrors of one of the circles in Dante's hell." We need not recall the invaluable services of Esquimaux Joe in sustaining the sailors of the Polaris on their voyage on the ice floe, or the many instances in which the narratives of arctic explorers quote the value of his people as guides, as proofs of the fidelity of the race.

The expense of maintenance of a party of Esquimaux, with white men as leaders, would clearly be less than that of a party of white men alone. It will further be evident that to dispatch Esquimaux in balloons would be a different matter from sending other people, because, no matter where the balloons might come down, unless in the open sea, the travelers, being used to shift for themselves, would be as much at home as anywhere else. And they would thus be able to support themselves, and also the single white man who might go with them in command. But—supposing of course it be possible to make the gas and the envelope of the balloon withstand the climate—it does not seem to us that high-flying, wind-driven balloons are the proper means to be employed. While any balloon system is open to objections, the low-flying balloon, just capable of lifting one man off his feet so that he can propel himself over the surface with a pole, and by the same means cause his balloon to jump over high obstacles, appears to be the most promising means of locomotion for traversing the palæocrystic sea. A party starting would, therefore, go in as many balloons as there were individuals; and the chances of failure of all the air ships would be materially less than if the expedition travelled in a single large balloon; while there would be the additional advantages of strength of fabric, easy handling, and possibility of stopping during adverse winds by merely mooring the air ships without discharging gas.

MIND READING AND CONJURORS.

We have recently witnessed two exhibitions of the alleged abnormal power of second sight, or, what amounts to the same thing, mind reading. One was the performance of Mr. J. R. Brown, who has acquired considerable reputation as a mind reader. His exhibition consisted in experiments intended to prove the existence of a genuine phenomenal faculty whereby he reads the thoughts of other people. The second was the exhibition of Mr. Robert Heller, the well known conjuror, and his assistant, Miss Heller, wherein the lady, blindfolded, ostensibly saw and described articles not visible to her, but known to the conjuror and his audience. The reader will observe the distinction. Brown seeks to prove a supernatural power by curious experiments. Heller, likewise, performs equally curious experiments, but candidly avows them to be part of his programme of illusions—in short, neatly executed tricks.

Mr. Brown's so-called manifestations have an advantage over those of spiritualistic and other wonder-working mediums, in that they are reared on a small basis of actual fact. And it is just this modicum of reality which has commended them to college professors and others seeking the solution of many perplexing biological problems. At the same time, the phenomenal nature of the mind reader's apparent power has secured for him a host of adherents from the ranks of those whose peculiarly framed intellects are always ready to believe anything which rises above the level of their comprehensions to be superhuman. Mr. Brown's ability seems to consist in an exceedingly delicate sense of feeling, doubtless cultivated by long practice; he is also endowed with quick perceptive powers, likewise trained, and possesses a sensitive nervous organization. By the aid of these not at all phenomenal powers, he is enabled to detect the involuntary changes either of the pulse, or the breathing, or in the muscles in the person with whom he is in contact. It is an old and well proved fact that a person who has performed any secretive action, which is on the verge of discovery by another, will infallibly and involuntarily indicate the fact by some such bodily motion as above noted. This mental peculiarity is constantly taken advantage of in the cross examination of witnesses in courts, and by detectives in seeking to fix proof of guilt on criminals. Guilty individuals will usually betray themselves by their physical behavior; thus their actions are carefully scrutinized. Nothing is better understood than that the mind strongly affects the body: witness the actions of blushing, becoming pale, trembling, weeping, and laughing, all of which are involuntary, betraying even to the dull-est observer the sentiments of the person affected. Deaf mutes can catch the meaning of persons conversing with them by the merest shades of change in countenance; and nothing shows more clearly how the perceptive powers may in this respect be developed than the fact that the deaf mute has long since ceased the constant spelling of words with his fingers, and has substituted, in an immense number of cases, slight symbolical signs with the hands, movements of the body, and facial expressions, which fully convey the ideas. We might multiply instances, all showing that Mr. Brown's mind-reading faculty consists in a keen perceptive faculty rather than in any supernatural mental qualification. Examples of this ability exist in deaf, dumb, and blind persons, who communicate with each other by touch of fingers. But sufficient has been suggested to account for Mr. Brown's ability to find hidden articles while grasping the hand of the concealer.

As the foregoing negatives the idea of any superhuman power, it will be seen that the mind reader and the conjuror practice their arts by similar means; and on comparing them we do not hesitate to say that Mr. Heller's tricks are immeasurably more mysterious than Mr. Brown's. Eliminating the idea of jugglery altogether, it is evident that, for Mr. Heller's lady assistant to name articles touched by him at random, requires on her part a wonderful exercise of the memory, to return the exact answer called for by the peculiar form of question; and on the other hand an equally marvelous celerity of thought is necessary on the part of the conjuror to frame exactly the proper question to convey the information to his blindfolded assistant without a moment's hesitation. Robert Houdin, in his "Memoirs," explains the immense labor involved in two persons thus learning what amounts to a new language, the intricacy of which is shown from the fact that the conjuror repeatedly asks questions which convey to his assistant the ideas of phonetic syllables, which the latter links together to form the names of persons designated.

THE COST OF THE EAST RIVER BRIDGE.

It is a curious fact that, in the construction of great public works in this State, the original estimates of the architects or engineers are uniformly exceeded. The two largest structures now in progress, the State capitol at Albany and the East river bridge, are both instances of the truth of the above. The capitol is, on paper, an imposing palace, covered with ornamentation of the most elaborate and expensive description. Its original estimated cost (some \$4,000,000) has already been far exceeded, and yet the building is not half finished. Indeed, so great, it is now said, will be the additional expense that it is seriously proposed to abandon the work rather than tax the people for the necessary outlay. Regarding the East river bridge, the cost first estimated by Colonel Roebling, in 1868, was \$7,000,000, exclusive of the land. After this engineer's death, his son, Mr. W. A. Roebling, succeeded to the supervision; and he, in 1872, three years after the work was begun, revised his father's estimate

and added about \$1,000,000 more. He stated, however, at the time that the probable total cost would be about \$9,500,000, an increase of size of the work having raised the expense some 8 per cent. That even this estimate was too low was proved in 1875, when the directors sought and obtained an appropriation, raising the sum to \$13,000,000. Up to the present time, \$6,000,000 has been expended, for which we have to show two anchorages, two completed towers, and the connecting wires across the river. There are yet the wire and superstructures, additional stone and masonry, land and labor, to be paid for, the total outlay for which, according to estimates obtained by the *New York Sun*, will swell the entire cost to \$17,569,000.

It will be interesting to compare this with the cost of tunnelling. The clear span of the bridge across the river measures 1,595 feet; so that for the actual means of transit, the cost is about \$11,015 per foot. Even measuring from anchorage to anchorage, a distance of 3,475 feet, the cost reaches \$5,056 per foot. Let us contrast these figures first with those shown in the results of submarine tunnelling. The first Chicago waterworks tunnel, 5 feet in diameter and two miles in length, cost \$457,844, or some \$43 per foot; the second bore, 7 feet in diameter and of the same length, about \$39 per foot. These are of course too small for traffic purposes, but may be quoted to aid us in reaching an idea of relative cost. The Thames tunnel can hardly be used for comparative purposes, since it was the forerunner of submarine excavation, and was worked upon over a period of some 36 years. Its total cost was \$2,000 per foot. Lately a very heavy tunnel belonging to the London Underground Railway has been finished under the London Docks. The work was exceedingly difficult, and the quantity of water to be pumped out enormous. The final cost was £390,000 per mile, or about \$369 per foot. Lastly, we have the estimates of the English channel tunnel, 31 miles in length, which amount to \$20,000,000, or about \$122 per foot.

Now we may glance at land tunnels. The Mont Cenis tunnel cost about \$300 per lineal foot, inclusive of equipment of road, etc.; the Kilsby (England) double track railroad tunnel, in the construction of which great difficulties in the form of quicksands were encountered, \$262.50; the Hoosac tunnel, \$300; Underground Railway, Fourth avenue, New York city, \$285; Bletchingly (England) double track tunnel, \$120; the very difficult Hauenstein tunnel between Basle and Berne, Switzerland, \$133; the contract price of the St. Gothard tunnel now in progress is £1,896,945, or about \$189 per foot. Many more examples might be given, but the above will suffice to show that in all probability \$350 per lineal foot would be a large estimate for a tunnel under the East river. Supposing for the sake of comparison that the total length of excavation be equal to the total length of the bridge, 3,475 feet (it obviously would be much less), its cost would be, at the above figures, some \$1,200,000. Consequently, for the sum now estimated as the probable cost of the bridge, New York might have at least fourteen tunnels crossing the river at as many principal streets.

Meanwhile the success of the bridge as an engineering work is by no means assured; nor is it certain that the estimate of \$17,569,000 will not still further be exceeded. The distance from the pier to the City Hall terminus on the New York side is 2,381 feet; on the Brooklyn side the distance from tower to terminus is 1,881 feet. The whole aggregates 660,000 square feet, or some 200 city lots, largely covered with buildings, to which title must be acquired. The estimate given fixes \$25,000 each for the lots; but in cities where real estate fluctuates so greatly as in New York and Brooklyn, it must be clear that any such calculation is merely an approximation.

Again—and we cannot gainsay the wisdom of the conclusion—the Board of Directors of the bridge are strongly opposed to take any risk of inferior material on account of an apparent economy in its cost. It has been a question for some time past whether the cables shall be made of Bessemer and open hearth steel, or crucible cast steel only. There appeared from the engineer's report a saving of some \$250,000 to be effected by the use of the former. Thus the Roeblings offered crucible steel at 9 cents per lb. gold, or for \$612,000, and Bessemer steel at 6 3/4 cents, or \$459,000 in all. The strain withstood by each, per square inch of section, was respectively 179,019 lbs. and 178,163 lbs.

Mr. Abram S. Hewitt, in a letter to the Board referring to Bessemer steel, said: "The peculiarity of that material is that it is apt to have weak spots of which there is no external indication. This is probably due to the enclosure of bubbles of air in the mass, or possibly to the oxidation of minute particles of the material while the air is being driven into it under high pressure. No amount of visual inspection can determine in what part of the ingot, the rod, or strand of wire, such defects will occur, and I have seen Bessemer rods break under apparently very inadequate strain." Finally, the Board, after carefully considering the question, concluded not to use Bessemer steel—and this even after proposals for the same had been invited—and awarded the contract to supply crucible cast steel wire to Mr. J. Lloyd Haigh (he being the lowest bidder), at the price of 8 7/10 cents gold per pound.

We said, nearly five years ago, that the probable cost of the East river bridge would be \$20,000,000. At present the indications are that our prediction will be realized; and judging by the rate of increase in previous years during the progress of the work, even the large sum we named may be insufficient to cover the actual cost of constructing the bridge.

THE MIGRATIONS AND DISPERSAL OF ANIMALS.

One of the most important considerations in studying the past history of the earth, as shown by the distribution of animals, is that which leads us to examine, first, what means animals of every class have for dispersal, and second, what barriers Nature interposes to prevent the same. It is a necessary part of the great struggle for existence, which pervades all life, that the creature shall encounter not merely active enemies but passive ones: not merely those which directly threaten its existence, but those which prevent its self-maintenance by cutting off its access to the necessary means of so doing: and against these last the organism is often compelled by force of necessity to oppose itself. Animals, even those which breed most slowly, increase with a rapidity out of all proportion to the available food in any specified district which they may inhabit; and therefore all are obliged to struggle against the obstacles which prevent them wandering in search of fresh hunting grounds or pastures.

Whether a certain natural phenomenon is or is not a barrier to further dispersion depends very greatly upon the class of animals inhabiting the region which it limits. Thus the elephant will climb the loftiest peaks and mountains, traverse rivers, and range the densest forests; the tiger can endure the widest extremes of heat and cold, and can swim moderate distances; but on the other hand, the monkeys, for example, must remain within the limits of forest vegetation, while the antelopes and zebras cannot exist otherwise than on the deserts.

Mr. Alfred Wallace, in his "Geographical Distribution of Animals," the underlying theory of which work we recently reviewed, devotes some very interesting pages to the above topic, considering in some detail the various obstacles to animal emigration. Climate seems to be a potent boundary to the travels of mammals, as there are such animals as the polar bear and walrus, which cannot live, in a state of nature, far beyond the polar ocean. But it is believed that it is not so much the climate itself as the change of vegetation consequent on climate which renders it effective as a barrier. It appears that valleys and rivers are often insurmountable obstacles, as animals which naturally exist on hills would be checked by the difference of vegetation and of insect life, and also by the unhealthy atmosphere often found in valleys. An arm of the sea over twenty miles wide cannot be traversed by land animals, by swimming; but on the other hand, long voyages are often made by mammals that are involuntary passengers on uprooted trees and ice floes. Bats and the cetacea have exceptional means of dispersal. The latter, however, find themselves opposed by temperature, as the polar species cannot cross the equator, nor can those indigenous to the tropics venture into the cold polar waters.

It would seem that no barrier could limit the range of birds, and that consequently they must be the most ubiquitous of living things; but this is far from being the case. The petrels and gulls are the greatest wanderers over the ocean, and the sandpipers and plovers roam over immense extents of coasts; but there are many species which are wholly checked by natural obstacles. The ocean presents an almost absolute barrier to prevent the birds of one continent passing over to another. Large numbers of birds cannot exist outside the forest countries; others cannot soar above the mountain ranges which bound their inhabited region. Again, the prevalence of their enemies is a potent barrier to birds dwelling in or crossing any region; and where nest-hunting quadrupeds, such as monkeys, abound, they are comparatively scarce.

We now reach that very interesting phenomenon known as migration; and here must be drawn a distinction between the true migrations of fishes and birds and the periodical movements of certain mammalia. Thus, in summer, monkeys ascend the Himalayas to heights of 10,000 and 12,000 feet; in dry seasons antelopes move southward toward the Cape of Good Hope. These differ from the great movements of fishes and birds, since such take place in large bodies and often to considerable distances. Migration may be looked upon as an exaggeration of a habit, common to all locomotive animals, of moving about in search of food; and in birds, it is especially exaggerated by their powers of flight and the necessity of providing soft insect food for their unfledged young. In North America, every grade of migration is found, from that peculiar to species which merely shift the limits of their range a few hundred miles (so that in the central parts of the area the species is a permanent resident), to others which move completely over 1,000 miles of latitude. So that, in all the intervening districts, such species are only known as birds of passage. There are many curious facts peculiar to migration, notably that of birds returning, year after year, to build nests in the same spot: a local attachment which prevents their wandering into localities unsuitable for them. Also that the old birds migrate first, the young following at random. This indicates the absence of imperative instinct in the habit, and it also accounts for the diminution in numbers of the young that return. On the succeeding year, however, the young profit by their experience, and fly when the old birds do. Another curious fact, however, in favor of instinct, is that "agitation" of caged birds at the time when their wild companions are migrating. This, however, Mr. Wallace considers to be due to a social excitement, due to the anxious cries of the migrating birds, and to be ascribable to some strong social emotion, gradually developed in the race by the circumstance that all who, for want of such emotion, did not join their fellows inevitably perished. The long flights of some birds, without apparently stopping on the way, is thought to be inexplicable, as well as their

finding their nesting place of the previous year from a distance of many hundreds or even a thousand miles. But the observant powers of animals are very great; and birds flying in the air may be guided by the physical features of the country, spread out beneath them, in a way that would be impracticable to purely terrestrial animals.

Reptiles are scarcely more fitted for traversing seas than mammals; but lizards evidently possess some unknown means, probably while they are in the egg state, of passing the ocean, since they are found to inhabit many islands where there are neither mammals nor snakes. Fishes are not without means of dispersal over land. Some are carried through the air by hurricanes; those living in subterranean waters have been thrown up by volcanoes. Geese and ducks often eat fish eggs without impairing the vitality of the same, carrying them meanwhile over long distances. Molluscs often attach themselves to animals or to fragments of wood and stone, and so are transported.

Winged insects possess more varied means of dispersal than any other highly organized animals. Many fly to immense distances; others are carried off by storms; and the floating trees which serve as rafts for mammals are the homes of myriads. Immense numbers of tropical insects are brought to the London docks in foreign woods; and they have often emerged from furniture, after lying dormant for many years. They will survive wonderfully hard usage. Many species can withstand hours of submersion in strong spirit; others can go for months without food.

But on the other hand, wide as is the distribution of insects, the barriers opposed to the same are equally great. Hundreds of species of *lepidoptera* can subsist, in the larval state, only on one species of plant; so that, on perfect insects being carried to a new country, the existence of the race would depend on the presence of the same or of some closely allied plant. Again, some require succulent vegetable food all the year round, and hence are confined to the tropics; some are dependent on water plants, some on mountain vegetation. Many are parasites of other insects; all have enemies in every stage of their existence; and the abundance of any one of these may render their survival impossible in a country otherwise well suited to them.

We have thus briefly reviewed the means which animals have for their dispersal about the globe, and the barriers which Nature has interposed to limit their wanderings. What effect these obstacles have exerted in determining the present distribution of animals, we shall consider in a future article drawn from the same source.

THE CAUSE OF THE DELAY IN ISSUING THE PATENTS.

We are in receipt of numerous letters from inventors, inquiring the cause of the delay on the part of the Patent Office in forwarding their patents, and also calling our attention to the fact that notices of their inventions have not appeared in these columns. In reply to all, we would state that, for the last two months, the Patent Office has encountered considerable difficulty in having the photo-lithographic copies of the drawings prepared. The acting commissioner has issued a circular, which is forwarded to individual patentees, in which each is informed "that, on account of the imperfection of the photo-lithographic copy of the drawing which was to accompany the patent, the Office was compelled to return the drawing to the photo-lithographic company for reprint. As soon as a perfect drawing can be procured, the patent will be forwarded to your address."

As fast as we receive copies of the delayed patents, we shall prepare and publish the usual notices. The difficulty has now existed since October 31; and while a few patents of subsequent dates have reached us, the large majority have yet to come.

A Prepared Codfish Patent Litigation.

The patent of Mr. Elisha Crowell, under which he claims a royalty on all cod and other fish deprived of skin and bones and packed in boxes, etc., for transportation, is to be contested by the wholesale fish dealers of this city. Mr. Crowell has heretofore issued stamps, which the trade purchased and affixed to the boxes of fish, at the rate of 1/4 cent per pound. The dealers now claim that this tax inflicts injury on their business, and that Mr. Crowell has no legal right to exact it. As a large number of merchants are associated in these legal proceedings, and as it is reported that other fish dealers throughout the country will co-operate with them, it is probable that Mr. Crowell's claims will be vigorously fought in the courts.

Six Tons of Gold.

Three million dollars in double-eagles recently arrived in this city on a Baltimore and Ohio railway car. The treasure, which weighed six tons, was brought overland from San Francisco, to be deposited in the New York Sub-Treasury. It filled fourteen iron safes, and was guarded by a squad of soldiers, and was in charge of eight Treasury Department clerks.

In our description of the Tomlinson axle box, on page 54, present volume of the *SCIENTIFIC AMERICAN*, the address of Mr. Tomlinson should have been: "Care of G. L. Kelly, 80 and 82 White street," instead of "C. L. Kelly," which was the name and address given in part of the edition.

Persons desiring further information may address Mr. Tomlinson as above, or Mr. James E. Crane, 76 Park Place, N. Y., or Wm. Knifton, Black Hawk, Gilpin county, Col.

IMPROVED COMPOUND ENGINE.

The object of this improvement is to facilitate the working of both engines by low pressure steam, when such working becomes necessary, as, for example, when war steamers are brought into action. This improvement is the design of Mr. Charles Sells.

Fig. 1 represents a section through the low pressure valve chest of a compound engine, in which the high and low pressure cylinders are on the same axis, showing an arrangement of steam and exhaust valves for operating according to the invention. A is the high pressure cylinder, and B the low pressure cylinder, having the slide facing C; D is the exhaust pipe from the high pressure, and E the exhaust pipe from the low pressure, cylinder; F is a branch from the main steam pipe; G is a duplex valve which can seat, either as shown in Fig. 1, in which case the exhaust from the high pressure cylinder flows into the valve chest of the low pressure cylinder, or which can be seated on the seating, *g*, in which case the exhaust from the high pressure cylinder flows by the pipe, E, to the condenser; H is a shut-off valve, which, when seated as shown in Fig. 1, prevents the supply of steam from the main steam pipe to the low pressure cylinder, but which can be opened so as to supply steam thereto when the valve, G, is seated on *g*.

Fig. 2 is a sectional plan of the cylinders, A and B, of a compound engine, placed side by side, showing an arrangement of valves for effecting the same purpose; C is the low pressure slide jacket; D is the discharge from the high pressure; E is the exhaust pipe leading to the condenser, and F is the steam pipe from the boiler; G is a duplex valve, whereby the exhaust from the high pressure cylinder can be permitted to flow into the reservoir supplying the low pressure cylinder, or can be made to pass to the condenser when the valve, G, is seated on *g*; H is a shut off valve which either cuts off or admits steam from the steam pipe to the low pressure reservoir.

It will be seen that the invention consists in arranging in connection with the cylinder valves by means of which the passage between the eduction of the high pressure cylinder and the low pressure slide jacket can be closed, and a communication can be opened between the low pressure slide jacket and the main steam pipe; so that, when it is desired to work with a considerably reduced pressure of steam in the boilers, both the high and low pressure cylinders are supplied with steam at the same pressure, and the eduction from both is led into the condenser, the engines being thus worked as ordinary coupled engines, and the combined areas of all the cylinders being thus utilized. We are happy to add that the Admiralty have been so impressed with the value of Mr. Sells' invention that the engines of the new fast unarmored ship *Iris*, 7,000 horse power, now being built by Messrs. Maudslay, Sons, & Field, will be constructed on this principle.—*The Engineer*.

A Valuable Antique Inscription.

In the Hippodrome at Constantinople may still be seen the remains of a venerable trophy of the Persian war, the bronze serpent which, with the gold tripod it supported, was dedicated to the Delphian Apollo by the allied Greeks after the victory of Platea, as a tenth of the Persian spoil. On the bronze serpent, which served as a base for the tripod, the Lacedaemonians inscribed the names of the various Hellenic States which took part in repelling the barbaric invader. The golden tripod perished long ago in the sacrilegious plunder of Delphi by the Phocians, but the bronze serpent remained in its original position till it was removed by Constantine the Great to decorate, with other spoils of Hellas, his new seat of empire at Byzantium. Here it has remained in the Hippodrome till our own time, not unscathed, for the last of the three heads of the serpent has long since disappeared; but the list of Greek States inscribed on the intertwined folds of the body remains perfectly legible to this day, having been fortunately preserved from injury by the accumulation of soil in the Hippodrome. This earth concealed about two thirds of the serpent till the excavation made in the Hippodrome in 1855, when the inscription was first brought to light. As the date of the battle of Platea was B. C. 478, it may be assumed that the setting up of the tripod took place shortly afterward. Thus the inscription would not be later than B. C. 476. Of hardly inferior interest is the bronze helmet found at Olympia early in this century, which, as its inscription tells us, was part of a trophy dedicated by Hiero I., of Syracuse, after his great naval victory over the Tyrrhenians, B. C. 474. If the German excavations now going on at Olympia continue to yield results as promising as the discoveries which have distinguished the first months of this enterprise, we may hope that many similar records of Hellenic triumphs may be found in the rich soil of the Altis.—*Contemporary Review*.

A NEW TUBE EXPANDER.

Mr. Alanson Work, of Providence, R. I., has patented through the Scientific American Patent Agency, October 10, 1876, a new tool for expanding hose couplings and applying them to the ends of sections of hose.

A represents the body of the tool, which receives the spindle, B. A square collar, *b*, formed upon the middle part of said spindle, keeps it from turning in the body.

The forward part of the spindle, B, has a screw thread to receive the lever nut, C, by which it is drawn forward. The rear part of the spindle is made conical, as shown. At D are sixteen, more or less, segments, which are arranged

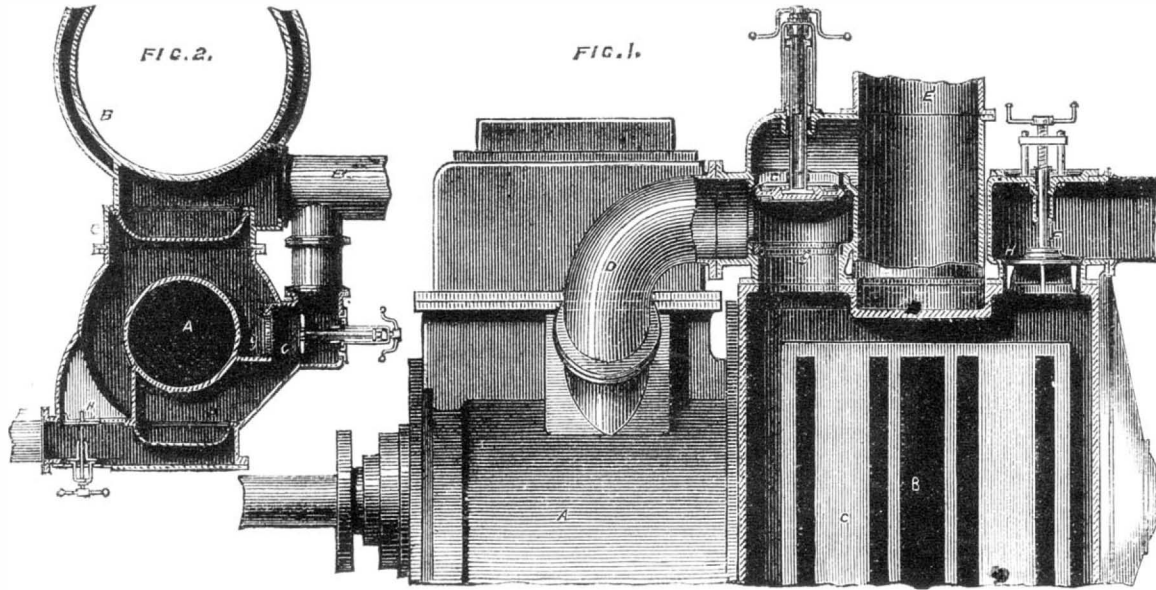

SELLS' COMPOUND MARINE ENGINE.

radially around and correspond with the incline of the rear part of the said spindle. The forward ends of the segments, D, have hooks, *d*, formed upon them to hook into radial mortises, *a*, formed in the rear end of the body, A, to keep the said segments always equally distant from each other, and thus prevent them from huddling or getting closer together in one place than in another. A rubber ring, E, holds the segments against the spindle, as the said spindle is withdrawn after expanding the tube.

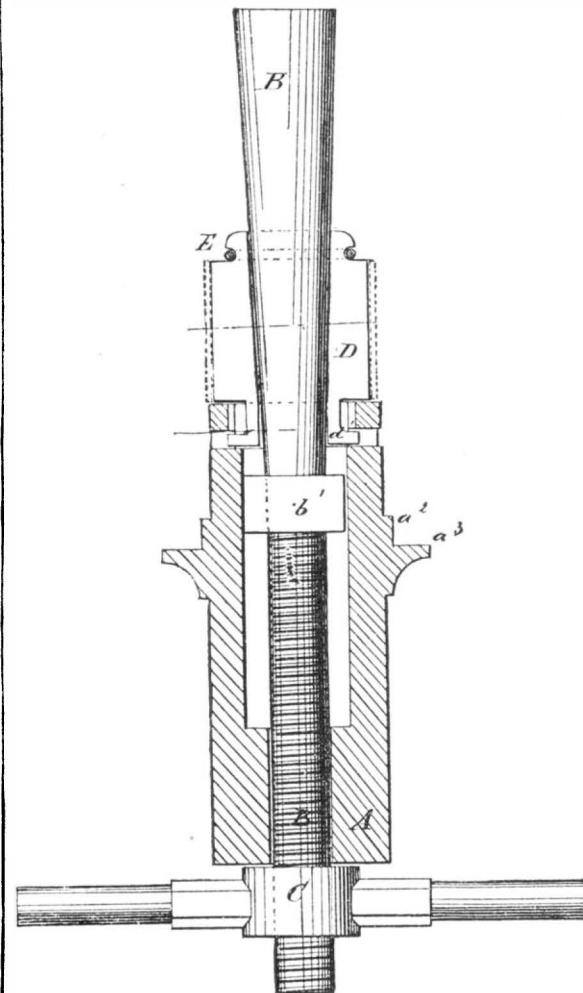

The copper tube to be expanded is placed upon the segments, D, with its forward end resting against the end of the body, A. Upon the rear part of the body, A, at the proper distance from its end, is formed a shoulder, *a*¹, for the end of the male part of the coupling to rest against, and a second shoulder, *a*², for the end of the female part of the coupling to rest against.

Wash for Trees.

Pour ten parts of boiling water on one of gas tar; and when cold, sprinkle peach, plum, and other trees, gooseberry bushes, and even standard roses before any bud appears; the same will be free from insects all the summer. You may safely paint the stems of trees, and the stems of young larch and forest trees, and it will entirely keep away hares and rabbits. Sheep or horses will not touch the stems of apple trees.—*Land and Water*.

Dr. Schliemann finds an Ancient Greek.

Dr. Schliemann's excavations at Mycenae are yielding results which are of immense value, not merely archæologically, but intrinsically, for he is exhuming gold in remarkable quantities. To print even the mere catalogue of the articles in precious metal which he has brought to light would occupy a large portion of this journal. Golden drinking cups curiously wrought, golden buttons, breastplates, diadems, figures of animals, leaves, personal ornaments (all in the most perfect condition), are daily found, and the coffers of the Hellenic Bank in Athens (where the treasure is deposited until it can be placed in a museum) are overflowing with wealth.

The most interesting part of the explorer's work is just now in progress, as he has at last reached human remains in a preserved state. Most of the bodies had been incinerated in the places where they lay; and it was evident that many had been robbed already. The signs of a shaft sunk into the tomb were noticeable, and the intruder had hastily collected the more valuable ornaments, and decamped. It is doubtful if the robber will be apprehended, as he accomplished his wickedness some time before the capture of Mycenae by the Argives in 468 B. C.—a fact shown by the absence of Greek pottery in the tomb, as such would have been there had the inhabitants of the Greek city, subsequently built over it, known of its existence.

In one tomb there were three bodies of gigantic proportions, which had been squeezed into the small space of six feet between the walls. Two were fragmentary, but the third had its face perfectly preserved under its ponderous golden mask. There was no vestige of hair, but both eyes were visible, also the mouth, which, by the enormous weight pressing upon it, had been forced wide open, showing thirty-two beautiful teeth. The nose had entirely gone, and the head had been pressed in such a way on the breast that the upper part of the shoulders was nearly in a line with the vertex of the head. From the top of the skull to the loins, the body, in its squeezed and mutilated state, measured two feet four and a half inches; and the entire remains had been pressed to a thickness of about an inch. Still the immense thigh bones left no doubt but that the man, when alive, was of very large stature; while the appearance of the teeth indicated that he died—or doubtless was killed, as he was a warrior—when he was about 35 years of age.

In color, the corpse resembled an Egyptian mummy. A broad golden shoulder belt lay across the loins; and from this was suspended a small bronze sword, on which was soldered a beautifully polished, perforated object of rock crystal, in the form of a jar with two silver handles. To the right and left of the body lay long bronze swords; and beside one of the swords, a bronze knife. These weapons had evidently been suspended from a belt, now gone. All the sheaths had been gilded, and were adorned with round buttons of gold, beautifully chased. The handles of the swords were gold plated, and exquisitely engraved. The massive golden mask which covered the head is 12½ inches in length and breadth, and is so thick that the enormous weight, which forages has been pressing on it, has made no impression. "It shows a round face, with large eyes and a large mouth much resembling the features of the body." Dr. Schliemann, in fact, is convinced that all the masks which he has found represent the features of the persons whose heads they covered. "A single glance," he says, "on these splendidly made masks must convince every one that they are real portraits and not ideal types."

When the news spread that the explorer had found a tolerably well preserved body, people flocked to Mycenae by thousands, from all parts of Greece, to view it. The corpse, however, threatened disintegration at any moment, and Dr. Schliemann in despair of keeping it sent for a portrait painter to prepare a picture of it. Luckily it lasted two days; and before that period had elapsed, a smart druggist, from a town in the vicinity, suggested soaking the remains in spirit in which gum sandarac had been dissolved. This was done; and Dr. Schliemann now thinks that, as the body can be lifted wholly on an iron plate which is beneath it, it can be removed to Athens unimpaired.

Wants to be an Editor.

A young man writes to the *Graphic* that he wants to be an editor, to which the *Graphic* editor replies: Canst thou draw up Leviathan with a hook thou lettest down? Canst thou hook up great ideas from the depths of thine intellect, and clean, scale, and fry them at five minutes' notice? Canst thou write editorials to measure? Canst thou write an editorial to fit in a three quarter column of the paper, which shall be in length just twenty-two inches, having three inches of fine sentiment four inches from the beginning, and nine inches of humor in the middle, and an outburst of maxim and precept, nine and three quarter inches long, at the close?

A NEW FOOD STEAMER.

Mr. Thomas B. H. Andrews, of Mansfield, Ohio, has patented through the Scientific American Patent Agency, November 28, 1876, an improved apparatus for steaming food of all kinds, boiling sugar, canning fruit, and for other purposes, which we illustrate herewith.

A represents the furnace, and B the steam chest, which is placed upon the same, and supplied with water for generating steam from a reservoir. The food-steaming box, C, is supported on an extension chamber, A', of the furnace, which may be made in one piece therewith, of cast or sheet iron, and separated therefrom by a hinged damper, C', so that the gases of combustion may be drawn through the same, or not. The furnace has two additional dampers—namely, a front damper, a, and a side damper, b—the hinged damper, C', and side damper, b, being closed when the apparatus is used, as shown in Fig. 1, for the purpose of steaming food. The smoke, etc., is then drawn through a pipe, d, at the rear of the furnace, and transferred to a short elbow, d', commonly closed by a cap, d². When the apparatus is used for boiling sugar or other purposes, the hinged damper is opened to draw the fire through the entire extension chamber for the heating of the evaporating pan, D, placed on the furnace.

The steam chest, B, is connected by a steam pipe, e, and branch pipes, e', with the food box, detachable pipes, f, with branching arms, f', that open near the bottom of the food box, being applied to the branch pipes, e'. The steam issues near the bottom of the food box, and is thereby distributed throughout the food, a cover being placed on the same to retain the heat. The food is thereby steamed in a quick and effective manner, while, by taking off the steam chest and food box, the furnace may be employed for other purposes.

NATURAL HYGROSCOPES.

A very simple and quite accurate little apparatus, for determining the degree of dampness in air or any other medium, may be made from the screw-shaped appendage of the seed of the *pelargonium*. To the species and varieties of this botanical genus the name geranium is popularly given though the *pelargonium* differs from the true geranium in several characteristics, the most obvious of which are the half shrubby character of the stems and the somewhat irregular flowers. The mode of constructing the hygroscope is shown in Fig. 1. E is the support of the *pelargonium* spiral, F, inserted in a block of wood. G S is a light wooden needle or piece of straw fixed by collodion to the spiral extremity. The end, S, turns over a dial, C D, divided as shown. On this circle, zero corresponds to the greatest humidity, and 100° to the greatest dryness. Between these extremes are traced five spiral turns, as the helix does not usually unwind on itself more than four times. Each turn marked is considered as beginning on the diameter, 0 to 100. Thus, for example, if the helix makes two twists and a half, the indicated degree is read on the

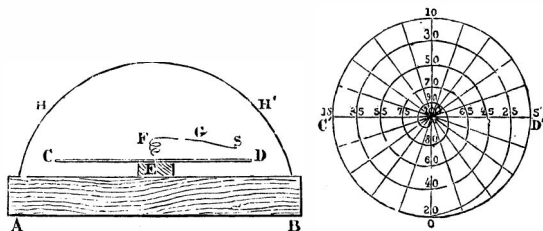

Fig. 1.

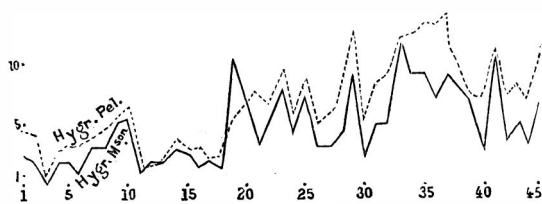

Fig. 2.

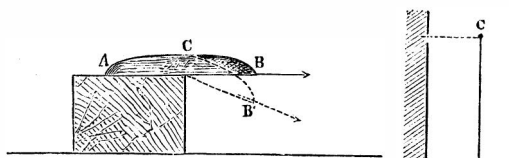

Fig. 3.

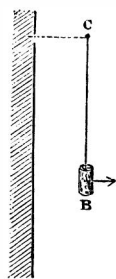
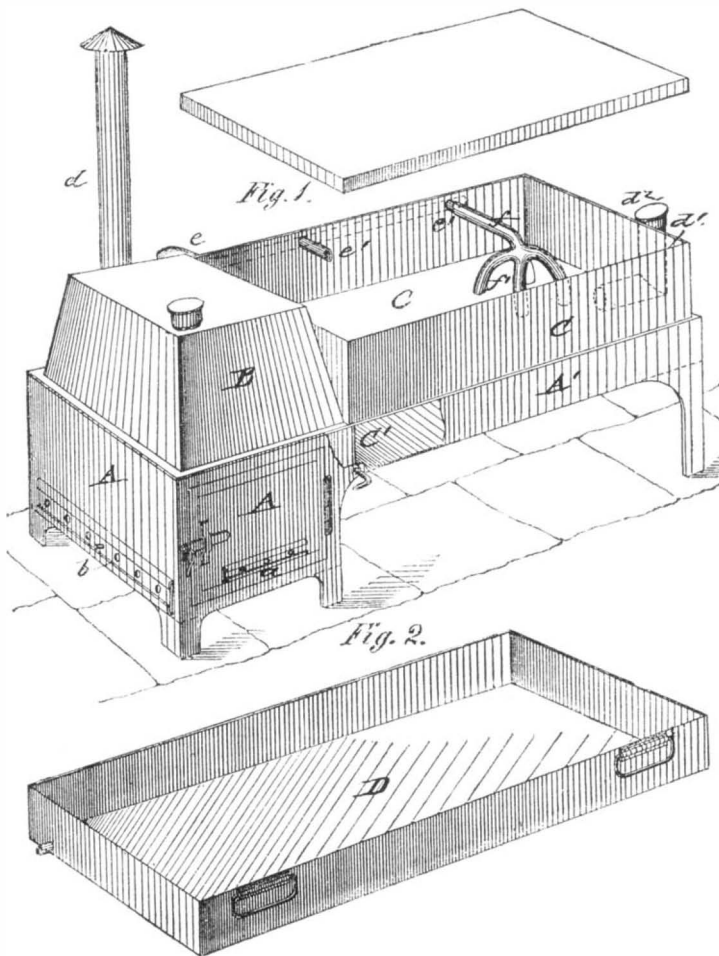

Fig. 4.

third turn of the spiral marked on the dial where the needle points to 50°. As the helix is quite fragile, a few copper wires may be arched over it, as at H H', to protect it from chance injury. Fig. 2 shows the indications of the *pelargonium* hygroscope, as compared with a Mason hygrometer of

fine construction. The accordance of the indications in it is quite remarkable.

There are two other hygrosopes noted by *La Nature*, which are even more simple than the foregoing. The first, Fig. 3, is a cork, B, in which a needle is inserted as a pointer, suspended from a nail by a catgut cord. The catgut cord contains more or less twist in proportion to the quantity of moisture in the air. The needle, therefore, as the cord turns, swings in one or the other direction; and by a little experimenting, a dial can easily be made from which



ANDREWS' APPARATUS FOR STEAMING FOOD

its indications may be interpreted. The simplest hygroscope of all is a ginger snap or spice cake, placed on a ledge, as shown in Fig. 4. This kind of cake is very sensitive to variations of humidity in the air; and when dampness is present, it bends, as indicated by the dotted lines, from C B to C B'. During dry weather, it returns to its horizontal position. A straw may be fastened to it as an index, and a dial, as above noted, be constructed by experiment.

NEW YORK ACADEMY OF SCIENCES.

The regular monthly meeting of the chemical section was held at the Mott Memorial rooms, Monday evening, January 15, 1877. Professor J. S. Newberry, President, in the chair. Notwithstanding the inclemency of the weather, the attendance was unusually large. Mr. Geo. F. Kurz exhibited

A NEW MINERAL

from Mexico, which contained sulphur, selenium, mercury, zinc, cadmium, and iron, in fact a sort of cinnabar, remarkable for the large percentage of selenium, about 1.8 per cent. It has been named *guadalcazarite*, from the locality where it was found. It is said to be sufficiently abundant there to be employed as an ore of mercury, thus furnishing a means of developing the silver deposits. Mr. Kurz also exhibited a specimen of *jeffersonite*. The first paper of the evening was by Dr. Peter T. Austin, on the

CONSTITUTION OF THE ADDITION COMPOUNDS OF PICRIC ACID WITH HYDROCARBONS.

The author first called attention to the fact that picric acid combines directly with hydrocarbons, like benzol, and that this property is often taken advantage of in preparing perfectly pure hydrocarbons, as some of these picric acid compounds are very finely crystallized, and may therefore be readily purified. Dr. Austin objected to the use of the term physical compounds as applied to these substances, claiming that there is but one class of compounds—namely, molecular compounds. After illustrating, by means of graphic symbols, the probable constitution of these molecules, and offering some facts in substantiation of his theory, he closed by stating that certain substances, like *paradinitro-benzol*, are more easily prepared from these picric acid compounds than from any other source.

LABORATORY NOTES FROM THE UNIVERSITY OF CINCINNATI, was the title of a paper by Professor F. W. Clarke, read by the chairman of the section, Professor Leeds. In the analysis of certain minerals, where it is customary to fuse them with bisulphate and fluoride of sodium, Professor Clarke finds that chloride of sodium may be substituted for the more expensive fluoride with but slight inconvenience. The mixture employed by him contains 3 parts chloride of sodium and 12 parts bisulphate of sodium to 1 part of the mineral. He recommends it particularly for refractory iron ores and for chromite.

Professor Clarke has succeeded in preparing a fluoride of nickel containing three molecules of water, Ni F₃, 3 H₂ O. It has a specific gravity of 2.15 at 19°, and retains the water at 130°. He also prepared a fluoride of zinc with four molecules of water. He was unsuccessful in making the fluorides of gold and of platinum.

Professor Clarke is perseveringly at work on the subject of molecular volumes. (See SCIENTIFIC AMERICAN, June 3, 1876.) He gave a list of 17 haloid salts, with their actual densities (determined by experiment), their molecular volumes, and the theoretical density calculated from their molecular volumes, which agreed in a remarkable manner. In all these cases, the volume was 5.5, 11, 16.5 or 22, all multiples of 5.5 the volume of hydrogen.

NEW METHOD OF DETERMINING FERROUS OXIDE IN SILICATES,

was the subject of a brief paper by Professor A. R. Leeds. It consists in the method of preparing and using hydrofluoric acid. The ore is pulverized and placed in a platinum dish which is supported on a platinum triangle within a platinum retort or still. The still is charged with fluorspar and sulphuric acid, and filled with dry carbonic acid. On heating the retort, dry hydrofluoric acid gas is evolved, which dissolves the ore and removes all the silicon. The carbonic acid is again passed through the retort until cold, when the ore may be removed, dissolved, and titered with permanganate of potassium. This furnishes the best means of determining the amount of protoxide of iron in an ore or mineral. The objection to the use of the liquid acid imported in gutta percha bottles is that it is not strong enough, and contains enough organic matter to render it totally unfit for use in determining protoxide in the presence of the peroxide of iron. Photographs of the apparatus employed were exhibited. It is to be hoped that some less expensive apparatus may be devised for this process, when it will, no doubt, meet with popular favor.

At the conclusion of Professor Leeds' paper, Professor Charles Seeley made some interesting remarks on

HYDROFLUORIC ACID.

This acid is now very largely employed in this city in making the ornamental glass signs, usually supposed to be made by the sand blast. This involves its preparation on a large scale, as some establish-

ments consume 100 lbs. per month. Iron retorts are employed, and are found to be better than lead, and last much longer than the leaden pipes which are attached to the retorts for condensing the acid. In regard to the physiological effects of the acid, Professor Seeley thinks the text books exaggerate its dangers. On dipping the hand into hydrofluoric acid, no immediate effect is produced; but if not washed off at once, in the course of half an hour the fingers begin to ache worse than the teeth with toothache; they swell up, and in a day or two the true skin begins to separate and crack open. These sores do not heal for two or three weeks. If, however, the hand is washed immediately in water or dilute alkali, no more inconvenience is suffered than from sulphuric acid. Lead bottles are used to transport it; and although gutta percha will last three times as long, its cost is much greater in proportion. Hydrofluoric acid can be made very cheaply, and sells in quantities at 18 cents per lb. Professor Seeley believed that it could be furnished here sufficiently pure to answer the objections raised by Professor Leeds.

HIPPOTAMUS DENTISTRY.

The hippopotamus now at the New York aquarium recently underwent that most disagreeable experience to all

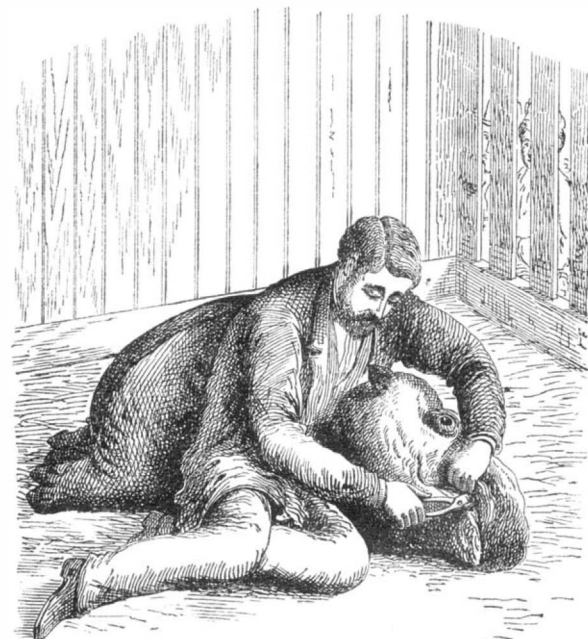

juveniles, the extraction of a tooth. "Baby," as the unwieldy young female is named, is now some twenty months old; and her second set of teeth or tusks are pushing out the rootless milk teeth. This is attended with considerable suffering, and the animal has been very uneasy, constantly rubbing her snout along the floor or against the bars of the

cage, and instinctively endeavoring in many ways to rid herself of the pain.

To remove a tusk from a grown hippopotamus would be rather a difficult and possibly a perilous proceeding; but Baby, who is but little larger than a good sized hog, is very gentle, and, when it was decided to resort to the forceps, she submitted to being rolled over on her side and only kicked and grunted moderately when, after two or three attempts, a strong pull and a stout twist wrenched forth the offending tusk. Dr. Kohn, the keeper of the hippopotamus, performed the operation, the main object of which was not only to relieve the animal, but also to prevent her swallowing the tooth. It is a curious fact that brutes in a wild state almost always swallow their milk teeth; and it frequently happens that they thus commit involuntary suicide. In members of the cat tribe, the teeth are quite large and sharp when they are shed, and it may easily be imagined that the keen points may produce serious wounds in the internal organs. This is a cause of mortality which we have not seen considered in natural histories, and which might exercise a potent effect in reducing the number of wild animals.

Dr. Kohn calls our attention to a curious phenomenon in relation to the hippopotamus, regarding which naturalists are not wholly in accord. It is known that, after the animal has remained out of water for a brief period, a handkerchief passed over the skin becomes colored with a reddish liquid. This is commonly believed to be an oily secretion, something analogous in quality to the oleaginous material which occurs in feathers of aquatic birds. If, however, the period of the animal's absence from water be extended, the skin becomes mottled with spots which, on close examination, prove to be true scabs. Microscopic examination of these, as well as of the red liquid, Dr. Kohn informs us, distinctly shows the presence of blood globules, similar in all respects to those found in the blood of the hippopotamus; so that it is hardly possible to conclude otherwise than that the animal actually undergoes a sweat of blood. The pores of the skin are unusually large and widely spaced apart; and at the orifice of each, a scab is formed.

Communications.

The First Steamboat on the Mississippi.

To the Editor of the Scientific American:

In the communication under the above heading, published in your issue of January 3, F. L. I. says that the *Navigators*, published in 1814, contains no information except that relating to the Orleans. Having been upon the river in 1831, I have preserved documents and papers relating to the history of steamboating in the West, in which I find the following facts: All statements in regard to the Orleans agree with those given by your correspondent, except the tonnage. The boats were, in custom house measurement: 1. Orleans, of Pittsburgh, 200 tons, in the year 1811; 2. Comet, of Pittsburgh, 25 tons, 1813; 3. Vesuvius, of Pittsburgh, 90 tons, 1814; 4. Enterprise, of Brownsville, 75 tons, 1814; 5. Etna, of Pittsburgh, 361 tons, 1814; 6. Despatch, of Brownsville, 75 tons, 1816; 7. Buffalo, of Pittsburgh, 250 tons, 1816; 8. James Monroe, of Pittsburgh, 156 tons, 1816; 9. Washington, of Wheeling, Va., 212 tons, 1816. Of the above I propose at this time to give the history of two only, and this because they were both commended by Henry M. Shreeve, to whom undoubtedly the honor belongs of having successfully established steam navigation on the Mississippi. The Enterprise, 75 tons, was built at Brownsville, Pa., on the Monongahela, by Daniel French under his patent, and was owned by a company at that place. She made two voyages to Louisville in the summer of 1814, under the command of Captain I. Gregg. On December 1, she took on board a cargo of ordnance stores at Pittsburgh, and sailed for New Orleans, commanded by Captain Henry M. Shreeve, and arrived at New Orleans on the 14th of the same month. She was then dispatched up the river in search of two keel boats laden with small arms for General Jackson's army, which had been delayed on the way. She returned to New Orleans with the cargoes of the keel boats, after an absence of six days and a half, in which time she ran 624 miles. For some time after she was actively engaged in transporting troops. She made one voyage to the Gulf of Mexico, one to the rapids of Red River with troops, and nine trips to Natchez. She departed for Pittsburgh on May 6, 1816, and arrived at Louisville on the 30th, twenty-five days out, being the first steamboat that ever arrived at that port from New Orleans. The citizens of Louisville gave a public dinner to Captain Shreeve for having accomplished in 25 days that which, up to that time, had never been accomplished by the barges and keel boats in less than three months. The Enterprise proceeded to Pittsburgh. The command was then given to Captain D. Worley, who lost her in Rock Harbor, Shippingport, Ky. Captain Shreeve, on surrendering the command of the Enterprise, proceeded to fit out the Washington, of 212 tons, the hull of which was being built at Wheeling, Va., and the engines at Brownsville, Pa. Shreeve's experience on the Enterprise had suggested some radical changes, which he proceeded to make in the Washington. It had been the practice on the boats previously built to carry the boilers in the hold, in the after part of which the cabin for passengers was also located. They were removed and placed upon the main deck, and a hurricane deck built on them. He rejected the upright cylinders of Fulton and the vibrating cylinders of French's patent; and he placed the cylinders in the Washington in a horizontal position, and connected them to the

water wheels with pitmans working on cranks at right angles. Fulton and French used single low pressure engines. Shreeve discarded these, and used high pressure. But his greatest improvements were the cam cut-off and the use of flue instead of cylinder boilers; and by using these, one half of the fuel was saved.

On September 24, 1816, the Washington passed Louisville on her first trip to New Orleans, and returned to Louisville in November. While in New Orleans, Captain Shreeve had an interview with Edward Livingston, who informed him that they (Fulton and Livingston) would commence suit against him for infringement on their patents. The severity of the winter compelled the Washington to remain at Louisville until March 12, 1817. On that day, she departed on her second trip to New Orleans, and performed this voyage by returning to the falls of the Ohio in forty-one days. The run from New Orleans to Louisville was made in twenty-four days.

It being now practically demonstrated that steamboats could ascend the river in one fourth less time than was required for barges and keel boats, the general public were satisfied that steam navigation was an established fact. At a public dinner given to Captain Shreeve, on the completion of this trip to Louisville, he predicted that the time would come when the trip from New Orleans to Louisville would be made in ten days. This statement was regarded in the same light that Stephenson's was when he predicted that locomotives would be run at 20 miles an hour. Both predictions were a long way within the facts. The trip from New Orleans to Louisville, that required twenty-five days to perform in 1817, was made by the A. L. Shotwell in 1853 in four days and ten hours.

All doubts in reference to steam navigation having been dispelled by Shreeve's success, shipyards were established, and the building of steamboats was actively commenced. Among those who were watching with intense interest the progress made by Shreeve was Edward Livingston. He claimed that, under patents owned by Fulton and Livingston, they held the exclusive right of steam navigation on all the rivers of the United States. Upon the arrival of the Washington in 1817 in New Orleans, Livingston commenced suit in the United States District Court. The Washington was seized by the marshal, and the case went to trial. Shreeve fought it out, and had the pleasure of hearing the claims of Fulton and Livingston declared to be unconstitutional; and the right of free navigation of the rivers of the United States by steam was secured to the people for ever. Geneva, Ill. EDWARD H. BEEBE.

Railroad Bridges.

To the Editor of the Scientific American:

Have engineers considered the plan of two or four strong wire cables to be braced and drawn tight under every span of all high dangerous bridges? It is the last feather that breaks the camel's back; and it is just a little too great a load, coupled with the motion of the train, that breaks the bridge. A plan that would supply this additional strength would seem to be what is needed. Would not wire cables, which never break suddenly, and are not much affected by the frost, be just the thing? Has a wire suspension bridge of so short a span ever broken? This plan would combine the truss and the suspension. It would seem as if it would be cheap and effectual in preventing the many such disasters as the one on the Lake Shore road. Certainly, with such disasters, the science of bridge building cannot be complete. There is much yet to learn. Ought not the State Legislatures or Congress to take hold of the matter? The cost of this plan on all dangerous bridges, even on a long line of road, would not equal the loss by the recent calamity, to which should be added the more important saving of hundreds of lives, and the loss of reputation of the line. And if all of the bridges on any of the great through lines were known to the traveling public to be thus secured, would it not greatly increase the patronage of such line? A. WATSON.

Washington, D. C.

Boiler Explosions.

To the Editor of the Scientific American:

I consider the explanation of explosions in boilers in the communication of E. G. A., of Monticello, Pa., to be entirely wrong. For if the boiler was merely hot enough to convert the water into steam, there would be no danger of explosion; the sudden cooling of the iron, and consequent unequal contraction of its parts, would merely strain the boiler and cause it to leak. According to my experience, the boiler has to be hot enough to prevent evaporating, which generates a gas causing the boiler to rend; and to effect this does not require "a large amount of water to be introduced." Again, the very fact that employers repose confidence in their engineers is conclusive proof that they are worthy of that confidence. And when the employer has been besieged by pedlars of patent appliances of every description, until he is bored to death, he, in order to get rid of them, sends them to the engineer, who, as a general thing, has enough to attend to beside arguing the merits of whatever article the agent may have to sell. His answer is usually short and decisive.

Now, as to low water reporters or alarms, there are a number of points in regard to their working, which E. G. A. should remember. In localities where there is any amount of vegetable matter in the water, it causes a sediment to be precipitated in the boiler: this sediment, entering the water end of the reporter, becomes, from constant disuse and from the fact that there is very little circulation in the pipe, solidi-

fied. This prevents the water falling in the pipe, so as to allow the steam to enter and blow the whistle, which is done by the hot steam expanding a brass tube which acts upon a valve connected with the whistle.

There is a rule, adopted pretty generally by insurance companies, to the effect that they will not insure a building containing a steam boiler, unless the said boiler has a safety plug. This plug is hollow, the hole being larger upon the inside than upon the outside. The hole is filled with a patent composition composed of tin and lead, and it is all right, so long as it is covered with water; but as soon as the water level falls below the plug, the more intense heat of the steam and iron melts the composition and blows it out. I think all engineers who desire safety would prefer the plug to any low water reporter, as, in case of low water with a reporter, a single cup of cold water dashed upon the brass tube contracts it, and stops the whistle; while, with the plug, the steam has to be allowed to run down before a new one can be inserted. This causes delay and the unavoidable disgrace of the engineer in charge, if the circumstance be due to his carelessness. AN ENGINEER.

Cambridgeport, Mass.

[We shall be glad to hear from engineers in response to E. G. A.'s strictures; but we would caution our correspondents that vituperation is not argument, nor is it likely to assist our readers in appreciating the merits of either opposing views. For this reason, we omit publication of some replies already received.—Eds.]

Ideation in Utero.

To the Editor of the Scientific American:

Two objections, which seem to me quite serious, suggest themselves against the "Ideation in Utero" theory, which you quote from the *English Lancet*. These are:

1. If the unformed brain of the embryo is capable of receiving any impression, and retaining the same during the long period which must elapse before a child's brain can develop sufficiently to enable the child to express its idea in speech, why is not the more perfect brain of the child after birth impressed by external occurrences (especially if of a phenomenal nature) sufficiently to produce memories afterward of events happening during the first few months of existence? In other words, is it reasonable to assert that the embryonic brain is capable of receiving ideas of locality, etc., when we know that the brain of the very young infant is not? Certainly no living person can recall any experience of the first year of his babyhood.

2. But, it may be urged, this impression is due in some mysterious manner to the close linking of the embryo and the mother's body. The circulating blood, therefore, must be the medium, since the nervous connection in the umbilical cord is but slight. Why, then, did not one Siamese twin influence the ideas of the other, when between them there was both a blood and a nerve connection, far more highly organized than any connection between child and mother, and on the integrity of which the actual lives of the brothers depended? It is well known that the mental and intellectual existences of the pair were totally distinct. B.

The Recent Railway Accident.

To the Editor of the Scientific American:

The accident that recently occurred at Ashtabula, Ohio, whereby about 100 persons lost their lives, of course brings forth many theories as to why the bridge gave way.

The bridge was a Howe truss, of one span 157 feet long, built at Cleveland, by the Lake Shore and Michigan Southern Railway; it had been in use about 11 years, and had stood the test of 6 heavy engines, and was considered safe by the chief engineer of the road, who stood on it but a few days before the accident while an engine was passing over, and could see no sign of weakness.

The engineer of the leading engine felt something give way when about two car lengths from the end, and pulled the throttle open wide, breaking the drawhead between the tender and train, and thus saving his engine. Some good engineers think that a portion of the train must have been off the track and struck and broken one of the chords, as the bridge fell one way and the cars the other. The chief engineer and others, including your correspondent, could not see the least signs of the cars being off when they went on the bridge; and if a single truck had been off, it would have left marks on the ties. Others think that the frost and the heavy storm raging at the time caused it to give way. My opinion is that the bridge had been greatly weakened by the vibration and concussion of passing trains. These and the cold weather, combined, caused it to give way.

For two years, I ran a printing press, printing forms just as large as would go on, so that the clamps came solid against the chases. When the bolts were made of the best iron I could get, they would break without any seeming cause, the iron looking crystallized and brittle. The strain could never exceed 30 lbs. on each bolt, the latter being 1½ inches in diameter. One broke in 66 days, having run about 286,000 impressions; the other broke three days after. I then had two pairs made of Swedish iron: the first pairs used ran for about three months. I then put in the others, putting a piece of wood ¾ inch thick between clamp and chases, when they run 105 days, and broke about the same time. They always broke in the same place.

Is it not probable that the same principle is at work on our iron bridges, and that the strongest will give way from this cause, if it be not renewed in time? J. H. S.

Erie, Pa.

PRACTICAL MECHANISM.

BY JOSHUA ROSE.

SECOND SERIES.—Number XIX.

PATTERN MAKING.

Our next example will be a pipe bend, such as is shown in section in Fig. 136. It will be seen upon examination that the bend proper is included in that portion contained within the dotted lines, C C and D D, which meet at the center from which the arcs forming the bend are struck. Those parts exterior to the dotted lines are made separately from the bend proper, and are subjects in plain turning, similar to those already treated upon. It will be noted, however, that in this kind of pattern the core is not so well supported as in our previous examples; and it has, therefore, a tendency to sag or droop towards the center of the arc, and also to rise above its proper level when the metal is poured into the mould. To obviate this, we must make the core, and hence the core prints, extra long, as shown by the dotted lines in Fig. 136. It is usual also to make a provision for fastening these external pieces to the bend proper as follows: The flange is one piece, the bend proper another, and the core print yet another. The core print fits into the flange, and

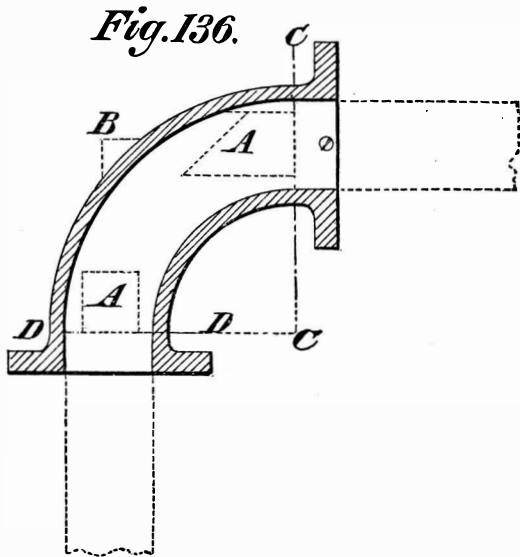

has a projecting piece extending into a recess or hole, provided in the bend proper to receive it, as shown, and thus is the pattern strengthened. If the core prints are made so short that the core overbalances itself when placed in the mould, the moulder inserts, into the mould, stays or supports to keep the print in position; and these supports are called chaplets. They consist of pieces of thin sheet iron bent to about the curvature of the core and riveted to a piece of wire, the device being pressed like a flat-headed nail into the sand. The piece of sheet iron represents the nail head upon which the core rests, and it is inserted into the cope and nowel so that they project the proper distance. They act to prevent the core from either sagging or lifting by floating upon the molten metal. Then, when the casting is taken from the mould, the projecting wires are chipped off, and that remaining in the casting is riveted. This trouble can be, in many cases, saved by simply making the core prints a few inches longer; besides, wherever there is a chaplet, there is an excrescence left upon the casting. In the case of large work, however, the matter is different, on account of the expense of making very long prints and their awkwardness in being handled.

The bend part of our pattern may be either turned in the lathe or pared by hand; and sometimes it is a difficult matter to decide which of the two will best answer the purpose. To turn up a bend, it is necessary to turn up a ring semicircular in section, as shown in Fig. 137, and of a radius corresponding to that of the required bend. This ring is then cut up into portions of the length of arc required, and about one half is in most cases left over. The advantage of this

Fig. 137.



method is the direct and ready manner in which the required form is obtained; whereas in paring and shaping, the bending by hand, though the operation be ever so skillfully performed, will not be so true as if turned. And when we consider that castings only three thirty-seconds of an inch in thickness are sometimes required, we perceive that the slightest error or deviation from the true shape will be perceptible, and will often result in the loss of a large proportion of the castings. For all small work, then, the turning is of decided advantage; but since such is not always the case with large work, and since the line must be drawn somewhere, a correct decision will always be largely influenced by the facilities afforded by the tools, etc., in the shop. In the example shown in Fig. 138, which is what is called a return bend, the whole of a ring, turned as above described, would be appropriated; therefore, there being no loss of material, the method by turning will in this instance always be preferable.

In fixing the half flanges for work of this kind, not exceeding six or seven inches in size, one screw passing through the center of the pattern into the flange will be sufficient.

Care must, however, be taken to hold the flange firmly in its exact position while boring for and during the insertion of the screw. It should not be forgotten to add the small projecting piece, B, shown in Fig. 136, which lies in the center line of each arm of the bend, which is provided to enable the casting to be conveniently swung in the lathe.

Fig. 138.

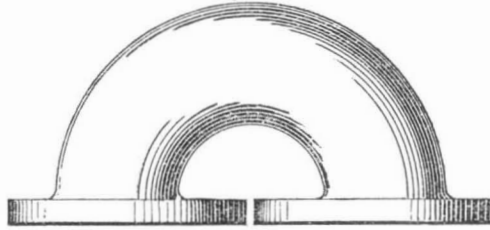

Before quitting examples of this kind, it will be well to once more direct the reader's attention to the core boxes, so as to impress upon him the important fact that, where equal thickness of metal is required, the core box should be as the pattern is. A round pattern demands a round core box; the one is of equal importance with the other. For example, in the designing of a bend, the required thickness is determined by the amount of internal strain to which the casting will be subjected. If, then, we give a round bend and an oval core box, we either make the bend too weak or we cause the manufacturer to pay for so many pounds of metal which he does not require. In the case of castings so thin as to require care to make the metal flow throughout the mould, an unduly thin place or spot will prevent the flow (at that part) of the metal, and thus spoil a large proportion of the castings.

A half core box for either a bend or a T may be made by preparing a block sufficiently large to cut out the whole recess, as shown by the full lines in Fig. 139. In this case, after the block has been surfaced truly on one side and edge, the grain of the wood being in the direction denoted by the arrow, the center lines are marked upon it, and also upon the pattern. We then lay one half of the pattern upon the block, and make the center lines upon them come exactly fair and even; and then we mark upon the face of the block the outline of the pattern, core prints and all. The core prints will of course be the right size of the core; but the outline marks thus produced form a guide to work by, and the distance between these outline marks and the edge of the core will represent the thickness of metal in the finished casting. A margin of stuff in the block is required outside of the outline marks, so as to give the core box sufficient strength. We next trace out a plan of the core, and then, upon the ends or sides of the block, we describe semicircles representing the exits of the recess to be cut out, the block being left so deep as to leave stuff enough below the depth of the recess to afford ample strength. We may now proceed to cut out the core by our hand tools, finishing it with the plane, shown in Fig. 14, and smoothing it with sand paper wrapped around a piece of wood of a sweep or curve a little less in radius than that of the core box recess.

Another method of getting out a core box for a bend is shown by the dotted lines in Fig. 139; and in this instance we make the core box in three pieces, the object being to turn up the end pieces, A A, in the lathe, the manner of pro-

Fig. 139.

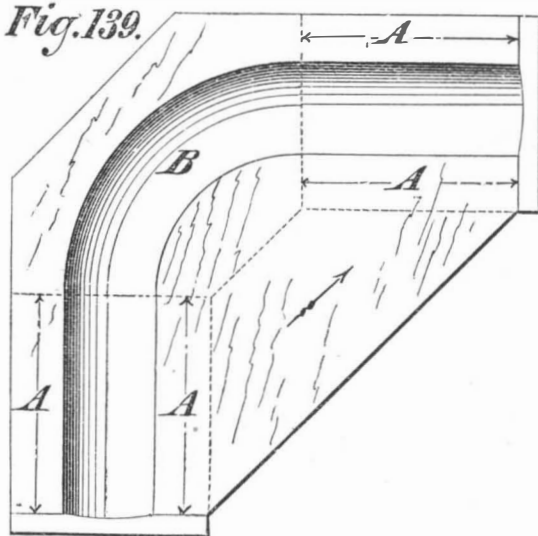

cedure being as follows: We get out the two pieces marked A A, and square up the faces truly, and chuck them, with the planed faces placed together in the chuck shown in Figs. 56 and 57, taking care that they are chucked so that, when the hole is bored in them, it will be half in each piece, or, in other words, chucking them truly, with the joint between the two. We then pare out the curved part in the middle section, and then glue on the end pieces, A A, and strengthen the whole by placing battens on the bottom and sides.

Fig. 140 represents a half core box for a T. In half core boxes, it is necessary to close the openings in the ends or sides by bradding on pieces of light board, taking care to give draught by paring them slightly concave at the top, and thus making the ends of the core similar to the slightly rounded ends of the pattern. When these pieces are omitted, the core maker has to extemporize them. When a full core box is required, as in the case of the oblique T, it is sufficient to mark the shape of the core upon one half only of

Fig. 140.

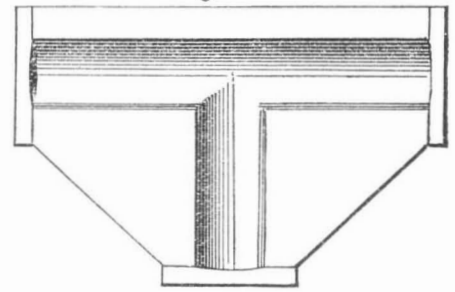

the box; and when this is cut out, we may place the two half boxes together, and trace the second half from the finished one, using a long bent scriber for the purpose of marking.

Cattle Food.

Experience teaches us that cattle thrive best on a mixed diet; all hay or all grain will produce less beef than hay and grain. The animal structure of the ox also demands bulk in food as well as richness: the feeding of concentrated food being only profitable so far as the animal assimilates it, beyond that simply increasing the manure heap at a cost far beyond its value. The ox has approximately eleven lbs. of stomach with only two and one half lbs. of intestines to each one hundred lbs. of live weight; the sheep has less stomach and more intestines, giving a smaller percentage of digestive apparatus; while the pig, for every hundred lbs. of his live weight, has only one and a third lbs. of stomach to six lbs. of intestines.

A steer would thrive well on a bulk of straw, with a little oil meal, that would shrink a sheep and starve a pig. Pork can be produced from clear corn meal, while mutton requires greater variety of food, and beef cattle would become cloyed and diseased with its exclusive use. A thoughtful attention to these broad facts will change much injudicious feeding into cheaper meat production.

One element in the economy of cattle feeding, the use of straw as fodder, has not received the attention its importance demands. On no one point is the average farmer so incredulous as regarding the value of straw to feed, and on many farms the wasteful practice still exists of turning all the straw into the manure heap. If properly made and reasonably well cared for, a large portion of the straw, especially of the oat crop, should be used as cattle food. Early-cut straw is worth for feed two thirds as much as hay, and is three times as valuable in feeding cattle as in the manure heap. Pea haulm and bean straw, especially if in the latter the pods are attached, are of still greater value. The best heat-producing foods are wheat, corn, oats, hay, and bran. Oat straw will develop as large a percentage of heat as oil cake; bean straw even more; and, in this respect, one hundred parts of oat straw are equal to eighty parts of hay. Straw is deficient in flesh-forming material, it requiring one hundred parts oat straw to equal sixteen parts good hay in this particular; yet, fed with cotton seed or linseed cake, it supplies what they lack in heat-giving and respiratory elements.

For the purposes of feeding out oat straw, our oat crop is allowed to over ripen, a large amount of its nutriment being lost without any corresponding benefit to the grain, which never improves after the upper portion of the stem has commenced turning yellow. Oats cut when just turning from the green state, yield more grain as well as greater feeding value in straw. The narrow margins of profit in cattle feeding in this section of the country demand the closest economies in the food supply, and the most thorough investigations and experiments with an article of so little present market value, and one of such abundance with most farmers, as oat straw.—*American Cultivator.*

Uses of Glycerin.

According to Klever, one hundred parts of glycerin will dissolve:

Parts.	Parts.
Acid arsenious..... 20-00	Mercury bichloride..... 7-50
" arsenic..... 20-00	" bichloride..... 27-00
" benzoic..... 10 to 20-00	" arseniate..... 50-00
" boracic..... 10-00	Potassa chlorate..... 3-50
" oxalic..... 15-00	" and iron tartrate..... 8-00
" tannic..... 50-00	Potassium bromide..... 25-00
Alum..... 40-00	" cyanide..... 32-00
Ammonia carbonate..... 20-00	" iodide..... 40-00
" muriate..... 20-00	Morphia..... 0-45
Antimony tartrate..... 5-50	" acetate..... 20-00
Atropia..... 3-00	" muriate..... 20-00
" sulphate..... 33-00	Soda arseniate..... 50-00
Barium chloride..... 10-00	" bicarbonate..... 8-00
Borax..... 60-00	" carbonate..... 98-00
Brucea..... 2-25	Phosphorus..... 0-20
Cinchona..... 0-50	Sulphur..... 0-10
" sulphate..... 6-70	Strychnia..... 4-00
Copper acetate..... 10-00	" nitrate..... 0-25
" sulphate..... 30-00	" sulphate..... 22-40
Iron lactate..... 18-00	Veratria..... 1-00
" sulphate..... 25-00	Zinc chloride..... 50-00
Iodine..... 1-90	" iodide..... 40-00
Lead acetate..... 20-00	" sulphate..... 35-00

Glycerin is particularly valuable as a solvent for gum arabic, as also in paste. Glue, by continued digestion, is soluble in glycerin, gelatinizing on cooling. Glycerin dissolves aniline violet, alizarin, and alcoholic madder extract. A solution of aniline color in glycerin is often used for stamping with rubber hand stamps. Glycerin is employed to extract the perfume from flowers, and the aromatic principle of red peppers. Sulphate of quinine dissolves in ten parts of glycerin when hot, but when cold separates in clots, which, when triturated with the supernatant liquid, gives it the consistency of a cerate, very useful for frictions and embrocations. Fifty parts of warm glycerin will hold in solution when cold one part of salicylic acid. Three hundred parts of water may be added without causing precipitation.

THE RESPIRATION OF ROOTS.

There are two functions peculiar to vegetables, which are often confounded: Respiration and assimilation. With air-breathing animals such a confusion is impossible, as their alimentation takes place only by the introduction into the digestive organs of solid and liquid matters, while respiration requires the penetration of oxygen into the lungs. With vegetables, on the contrary, the function of nutrition involves not only the introduction, through the roots, of substances soluble in water, such as nitrates, ammoniacal salts, and phosphates, but also the introduction of carbonic acid gas through the leaves. The latter also take oxygen from the atmosphere; and if the plant ceases to grow when it no longer finds carbonic acid gas in the air about it, and if this privation produces death through inanition, so also the plant perishes when deprived of oxygen, dying in such case through suffocation.

The leaves thus play the double part of organs of assimilation and organs of respiration; but the two gases which penetrate into the tissues act very differently. Under the influence of solar rays, the leaves decompose carbonic acid and emit oxygen. The carbon remains in the plant, when it is found united with water, forming those compounds—such as cellulose, starch, sugar, etc.—as are commonly called hydrocarbons. The penetration of carbonic acid into the leaves and the decomposition by light which it there undergoes are necessary to the growth of the plant, and thus constitute a phenomenon of assimilation.

Oxygen also enters the leaves, but its action is not well understood. Why a plant perishes when deprived of the gas is not definitely known; but it is certain that oxygen is not only necessary to the air-breathing organs of vegetables—the leaves, flowers, and branches—but equally so to the roots.

In order to determine the effect exercised by plant roots on the atmosphere of the soil in which they are buried, M. Vesque has recently undertaken a series of experiments, the description of which, with the annexed illustrations, we find in *La Nature*. To examine whether roots consume oxygen as do other vegetable organs, plants of various kinds were set out in vases filled with pulverized pumicestone. A soil absolutely free from vegetable matters was necessary in order to render it certain that such changes as might occur in the atmosphere about the roots were due to those organs, and not to the oxidation of carbonaceous matters which exist in arable earth. The arrangement of apparatus is shown in Fig. 1. The vessel, A, has three mouths, in one of which the plant is sustained by a stopper of rubber; the second, *c*, has a stopper and cock, and the third, *a*, has a thermometer and a mercury manometer, *b*. Water for watering the plant is admitted at *d*, the water coming from the funnel, C. In order to prevent bubbling and the consequent modification of the atmosphere in

Fig. 1.

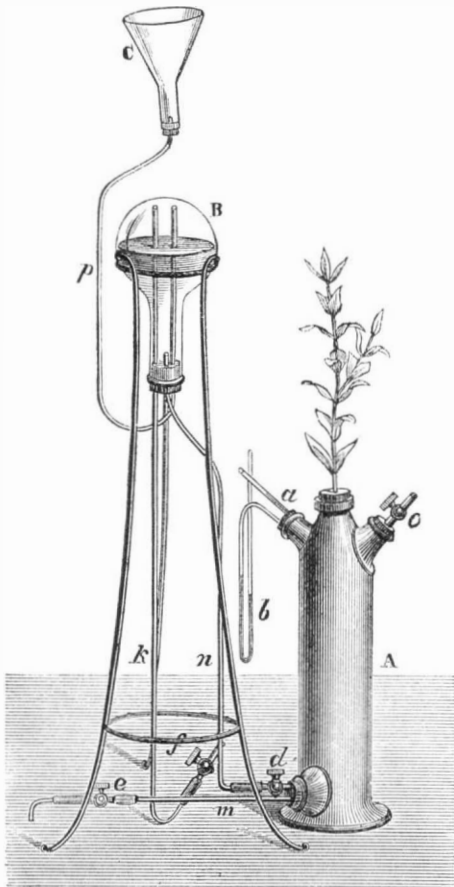

the vase, A, the water from the funnel is led into the reversed flask, B, where the air contained in the water is caught. The water then passes off to the plant vase through the tube, *n*, and rises in said vase until it escapes at the cock, *c*. The cock, *d*, is then closed, and that at *e* opened, when the water runs off to a vessel under the table, the pumicestone in the vase being left sufficiently moistened to answer all needs of the plant.

When it is desired to remove a certain quantity of air from the vase, A, for analysis, the apparatus represented in Fig. 2 is used. The vessel, D, is attached to a musket barrel and filled with mercury, in which is plunged a pipette, E, having a glass cock. A vacuum is thus produced in the pipette, and

it is connected with the cock, *c*, of the vase, A, Fig. 1. In Fig. 2, the connection is established with a bell glass covering the leaves. The cocks, *c*, Fig. 1, and *i*, Fig. 2, are then opened, and the air from A rushes into the pipette. This air is then drawn off into a suitable vessel and analyzed. It is always poor in oxygen, but it contains a small quantity of carbonic acid. The quantity of the latter being a small fraction of that of the oxygen consumed, there is a diminution of the volume of air contained in the vessel enclosing the roots—a fact also shown by the manometer. Thus, like the leaves, branches, and flowers, the roots respire, and the oxygen consumed is not integrally replaced by carbonic acid.

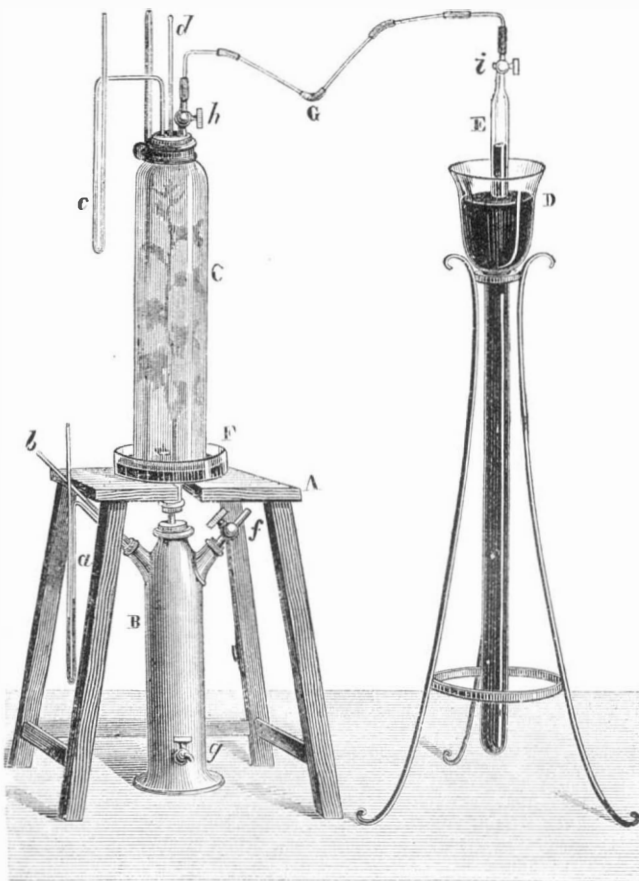

Fig. 2.—MM. DEHERAIN AND VESQUE'S APPARATUS FOR STUDYING PLANT RESPIRATION.

It is easy, by means of the apparatus shown in Fig. 1, to replace ordinary air with pure oxygen. The absorption of that gas by the roots is considerable, and the manometer indicates that a partial vacuum is formed in the containing vessel, and that carbonic acid is emitted. The plant lives very well when its roots are thus plunged in oxygen; but when nitrogen or carbonic acid is substituted for the latter, it dies.

It will be seen, therefore, that the respiratory function of the plant is not localized in any one organ, and that all its parts must be in contact with oxygen. This shows the great advantage of draining land. Water in marshy soil hinders access of the air, and the roots therefore keep near the surface where they can best obtain oxygen. When, however, the soil is thoroughly penetrated by drains, the roots go down to the subsoil, where they still find the necessary gas. Hence this allows the plant to gain sustenance from a larger amount of soil, and the development of these organs is promoted.

While the roots are organs of absorption of soluble matters, they also absorb carbonic acid. By means of the apparatus shown in Fig. 2, the leaves and roots may be enclosed in different atmospheres. The carbonic acid supplied to the roots passes to the leaves, is decomposed, and thus charges the vessel, C, with oxygen.

M. Vesque proposes to carry these investigations much further, and doubtless will reach many other important and interesting results.

How Do You Keep Your Books?

We believe, says the *American Cabinet Maker*, that there is a considerable proportion of men engaged in business—men who know how to buy goods, and can make a good sale of the same—who do not understand the details of keeping accounts. These men go on, year after year, without this knowledge, content if they find enough money in their drawer or at their bank to meet their bills. But, when you talk to them about a balance sheet, they immediately show a lamentable ignorance of the rules by which it should be made. Such ignorance may be very well when trade is flush and the skies are bright; but when the screw of hard times is applied, they are like the captain of a rudderless ship, who does not know when or how the rudder was lost. Partners go on drawing out money for personal expenses exceeding in amount the profits of the business, but they fail to see that this excess diminishes the capital of the concern. A and B form a partnership, and put in \$15,000 each. If each draws out \$2,500 for living expenses during the year, there must be a profit of \$5,000 made by the business in order to keep the capital at its original figures. If the profits fall below the amounts drawn out, the capital is diminished by whatever that difference may be. This is simplicity itself, and it requires no special education to understand it.

Therefore, if a business man understands how such a sheet should be made, he has no excuse for not knowing just how he stands.

Buy Small Trees.

Nurserymen usually describe trees on their catalogues as "second class," "medium," "first class," and "extra." The difference in these classes is principally, if not wholly, in the size and height of the trees; and as most farmers desire the best, they suppose that the large "extra" trees merit that description, and hence order them. The fact is, however, that a small tree will grow faster and (if a fruit tree) come into bearing condition sooner than a large one; and, as the *New England Homestead* states, in half a dozen years the tree that was small when planted will be larger and finer than the other. The larger the tree, the larger the roots which it has, and the larger the roots the less fibers there will be upon them. A tree that has plenty of fibrous roots will grow readily if proper care is used in transportation; but no amount of skill can coax a tree to live and flourish which is destitute of these little fibers. The roots of large trees are always more or less mutilated in the process of taking up, while small trees sustain little injury from this source. Dealers in trees assert that experienced men buy small, thrifty trees, while those who are just starting are anxious for the largest to be had. Those who are to set trees the coming season will do well to learn from the experience of those who, at considerable loss to themselves, have demonstrated that small trees are the ones to buy.

IMPROVED LOCOMOTIVE SPARK ARRESTER.

An improved spark arrester for locomotives has been patented through the Scientific American Patent Agency, November 14, 1876, by Mr. Simon Smith, of Mauch Chunk, Pa. As shown in the illustration, there is an inside and outside stack, and an annular space between the same. To the top part of the inner stack is attached a cone, B, which is extended partly downward into the interior, and partly around the outside of said stack. The cone terminates at the lower end with a tapering deflector, C, against which the exhaust steam and sparks strike in their upward motion. Above is arranged a cylindrical wire netting, D, through which the steam escapes to the outside, while the sparks are passed up to the annular top part, E, of the cone, which forms a conducting channel for them. Below the top part is again arranged a cylindrical wire netting, F, through which any steam carried around to the outside may escape, while the sparks drop down in the space between the inside and outside stacks to pipes communicating with the dirt box, from which they can be let out at the will of the engineer. The tapering deflector, C, that extends down through the inner stack, divides the steam and sparks gradually while passing up through the stacks, and avoids thereby the difficulty arising from the reaction

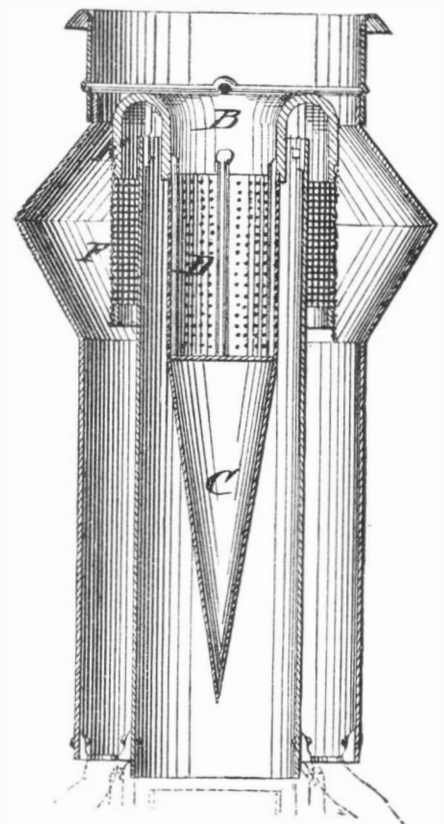

of steam and sparks by the direct impact of the steam on the horizontal bottom of the steam escape. A free escape of the exhaust steam and a free draught for the fire is thus secured.

Metropolitan (Underground) Railway, London.

The *Pall Mall Gazette* states that the Metropolitan Railway, with a traffic almost exclusively in passengers, is the most economically worked railway in England. During the last year it earned £100 for every £39 which is expended, being 32 per cent better in this respect than the average of English lines. At the same time its revenue per mile was between nine and ten times that of the average, exceeding \$200,000 per mile.

THE PRICKLY COMFREY.

Our illustrations represent a plant now much recommended, by the French scientific journals, to farmers, as yielding large quantities of excellent forage. It is known as the prickly comfrey, its botanical name being *symphytum asper- rimum*. With regard to the rapidity of growth and amount of herbage yielded by it, the *Journal de l'Agriculture de la France*, of October 7 last, says: "Two sets put late into the ground in the month of May, in a fairly deep soil but of poor quality, gave on September 29, the one 7,150 lbs. forage, and the second 3,850 lbs. The height of each plant was 15 inches, diameter 32 inches. The appearance was that of the small engraving, Fig. 2, which was drawn from nature at the Botanical Gardens, Kew, in England. Two cows, to which we offered the leaves freshly cut, ate them at once, in spite of their roughness. The quantity of water is 88 per cent, and the proportion of ni- trogen 0.4 per cent in the green state, or about the same as in green Indian corn. The total of nitrogenous sub- stances is about one third, a remarkable richness, justifying the high opinion cultivators who have tried it have formed of the plant. The sets we ex- perimented on were sent us by M. A. E. Ragou."

The *Journal d'Agriculture Progres- sive* says: "We persist in recom- mending this plant, chiefly for small and middle farming; those who farm on a large scale will probably adopt it all in good time. The price of the plant is high; but we must not forget that a thousand plants will yield from fifteen to twenty thousand the year fol- lowing, and that the planting of these sets, the original price deducted, does not cost more than pricking out cab- bages, and less than does planting po- tatoes."

The following letter, dated October 30, from Culloor, in Malabar, Madras Presidency of British India, was re- ceived by *Land and Water*, from the pages of which we select the engrav- ing:

"Thus far I am glad to be able to report most favorably on the progress of the comfrey roots I brought out with me here for the Tambracherry Coffee Estates Company. I have had them planted on a low, marshy soil, in ridges three feet apart, taking care previously to have the soil broken up two feet deep, and at subsoil of the ridges mak- ing a good coating of cattle manure mixed with jungle soil. By this culti- vation the roots will not only have con- siderable depth of soil to grow in; but in the event of having a dry season, the manure, being placed at a fair depth under the top soil, will tend to make it moist for a very consid- erable time. I was greatly surprised at the quick germinating qualities of these roots, which, in several instances, had not been planted more than forty-eight hours at about three to four inches below the surface, and had appeared in that time one inch above the surface. I also found, after a voyage of six weeks from England, on opening the case, that the roots had germinated a little. The comfrey has now been planted about ten days, and promises well. I only hope our cattle will take to it here, as, being so quick in growth, it will be invaluable, in my opinion, here on coffee estates as a stand- ard food for cattle: grasses being often difficult to obtain



during some seasons of the year. I shall advocate its trial to my agricultural friends in England. I am surprised it is not more generally grown. To a dairy farmer it would be an acquisition. I confidently expect to get here a crop every two months, if not more frequently."

Sand and Water.

An important point in the selection of materials is to procure a pure silicious sand for mixing with cement or lime to

form mortar. The sand used should be free from all nitro- genous, and some saline matters, such as alkaline chlorides; if not, these matters are liable to undergo a chemical change, after being mixed with the lime and cement, and so cause a rupture of the work even after it has set. For cementing purposes, for mixing with cement, a sharp sand is undoubt- edly the best. It would be a saving of cementing material to select sands of various degrees of fineness so as to reduce the interstitial space as much as possible. Pure silicious sand forms, in combination with the limes, a silicate of lime which augments the strength, especially in those parts ex- cluded from the air, as the interior of thick walls. Sand acts as



SYMPHYTUM ASPERRIMUM.

a dilutant for cement, so that its approximate strength, within certain limits, may be arrived at by knowing the proportions of sand used.

With regard to the selection of water, either fresh or sea water may be used for mixing with Portland cement. It has been shown by Mr. J. Grant, C. E., that the use of sea water augments the strength of Portland cement. This may be due to certain combinations taken place between some of the salts in sea water and the cement; on the other hand, the excess of certain salts will undoubtedly injure the cement. Sewage water, for example, should on no account be used in com- poundjng mortar. The author has seen cases in which the best materials, both as regards cement and sand, have been used; but when mixed with sewage water the cement has never properly set, while the same cement, in the same work, compounded with pure water, has set rapidly and well. Care should also be taken in the mixing of cement that too great a proportion of water is not used. The smaller the quantity of water used in the compounding of cement, the better it will be found to be. The volume of water to be used, therefore, should only be sufficient to bring the mortar into a thick paste. Where more water is requisite, it is a sign that the bricks or other materials which are used in the construction of the works have not been sufficiently soaked, and that the mortar is robbed of its moisture, by reason of the inattention paid to this important point.—*Engineering News*.

A Sinking Island.

The Island of Heligoland is reported to be gradually dis- appearing. It is now, says *Iron*, less than a mile in super- ficial extent; but in 1649 it was four miles in circumference, in 1,300 forty-five miles, and, in 800, a hundred and twenty miles. The encroachment of the sea is effected almost en- tirely from the northeast, owing to the set of the currents and the direction of the prevailing winds.

In painting woodwork, a priming coat followed by a dark coat, such as chocolate or purple brown, and finished off with a coat of common varnish, is cheaper than, and as durable as, four coats of common color; it looks better, is more rapidly executed, and stands washing well.

A MIXTURE of 96 parts salt, 20 parts caustic soda, 1 part extract of oak bark, and 4 parts potash, is recommended as a preventive of incrustation in boilers.

A Few Modest Hints.

Although the depression in the iron trade, says the *American Manufacturer*, is very great, and almost universal, the manu- facturers of agricultural implements and hardware, as well as certain other lines of goods, are doing a good business. Especially is this the case in the West. The activity in the farming implement branch is doubtless due to the fact that the tillers of the soil have enjoyed a succession of years of prosperity, and that existing in the hardware branch of man- ufacture is attributable, no doubt, to the fact that this busi- ness is not overdone, as is the case with many other branches, and to the further fact that American hardware is crowding the foreign into narrower limits, not only in this country but in many for- eign markets. There is in this a lesson that manufacturers would do well to heed. It shows that if the demand for some manufactures is less than the productive capacity of the works, for other productions it is not. Indeed, the import figures furnished by the Bureau of Statistics show that for many kinds of goods which could be pro- duced with advantage in this country the production is either *nil* or totally inadequate to the demand. So long as this is the case capitalists ought not to complain that there is no use for their money.

What is needed is diversity. There should be a branching out into the man- ufacture of the finer grades of goods. When one looks over the long list of imports and notes how many might be profitably produced at home, he is struck with amazement. The production of iron rails, of many forms of merchant iron, of certain kinds of glass goods, etc., has outgrown the demand; but is this a good reason for allowing the works at which these are made to stand idle or go to decay? Why not use the buildings, the power, as much of the machinery and as many of the em- ployees as possible in producing articles for which there is a paying demand? Let the owners of such works look over the list of our imports and see if there are not many things which they could produce without making any costly changes in their plan; and let capital- ists ascertain in the same way if there is not room for the profitable employ- ment of their money in erecting and operating new works for the production of goods not now made in this country. This would be more enterprising at least, and we hope more profitable, than waiting, Micawber-like, for some- thing to turn up. Our English cousins

set us a good example in this respect. When one branch of business becomes overgrown, they adapt their works for the production of something for which there is a better demand. Is the iron rail business overdone? then they make the ne- cessary changes for the production of steel rails. Is the pig iron of the vicinity unsuited to this? then they put their ex- perts to work to see if an iron rail cannot be made that will compete strongly with steel rails. Their boldness and energy in opening foreign markets are also worthy of emulation.

CHEMICAL MAGIC.

A subscriber to *La Nature* communicates to that journal a simple trick, which is as deceptive as many of those per-

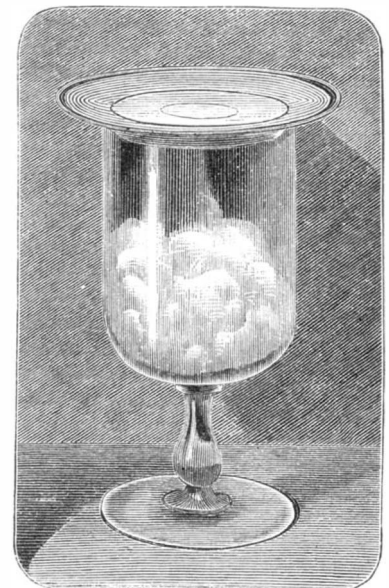

formed by professional "magicians." It is proposed to place the fumes of a cigarette, smoked by the operator at some distance, in a closed goblet, as shown in our engraving. The goblet is to all appearance empty, and the phenomenon of the white smoke wreaths inexplicable. But the vapors are formed by the admixture of muriatic acid and aqua am-

monia, two or three drops of the former being put in the goblet, and the covering saucer being wet underneath with the latter. The quantity of the liquids is so small as to pass unperceived; but as soon as the saucer is placed on the goblet, white vapors of muriate of ammonia are formed, which closely resemble tobacco smoke.

The Analysis of the Diamond.

The great French chemist Lavoisier undertook the examination of the diamond, and it is worth while noticing how carefully he went to work, how he proceeded slowly from one step to another in logical sequence, until he arrived at the true solution of the question he had undertaken to investigate: that is, until he was able to tell us exactly what happens when the diamond evaporates in the free fire, and why it did not do so when surrounded by charcoal. In the first place, he evaporated the diamond by means of the burning glass, and he observed that no visible vapor or smoke was given off, but that the diamond disappeared. He thought that perhaps the solid diamond had in some way been dissolved by the water, and that by evaporating the water, which was in the lower part of the bell jar in which he burnt his diamond, he might obtain the constituents of the diamond in a solid form; but he found that no solid residue was left on evaporation, and thus no trace of the diamond could be found. His next experiment was that of placing a diamond in the focus of a less powerful lens than the one he had formerly used, so that the diamond was not heated to so high a temperature as before, again placing it, however, in a bell jar over water. He then found that the diamond, when not heated quite so strongly, lost only about one quarter of its weight; it did not disappear altogether, but the remarkable fact was noticed that it became covered with a black substance which Lavoisier describes as being exactly like lampblack or soot, so that it dirtied the fingers when touched, and made a black mark upon paper. Hence Lavoisier concluded that the diamond is susceptible of being brought under certain circumstances into the condition of charcoal, so that it really belongs to the class of combustible bodies. He was, however, yet far from having proved this point, and he went on experimenting. He next measured the volume of air in which he was going to burn the diamond, and found it to be eight cubic inches. Then he burned the diamond in this volume of air by means of a lens, and found that the air had diminished to a volume of six cubic inches: thus showing that the air had undergone some change by the combustion of the diamond, and that two out of the eight volumes of air had disappeared. The next experiment he made was to examine the condition of the air in which the diamond had been evaporated. What changes had gone on in the air in consequence of the evaporation of the diamond? After allowing the glass in which he had burned the diamond to stand for four days, he poured clear lime water into the jar in which the diamond had been evaporated, and he says this lime water was at once precipitated in the same manner as if it had been brought into contact with the gas evolved in effervescence and fermentation, or that given off in cases of metallic reduction. Here, then, he had got on the track of what he wanted. Hitherto the diamond had apparently disappeared, and nothing was found to account for its disappearance; but now he had found that there was something contained in the air in which the diamond was burned which was not contained in that air before.

The next step he took was to examine the white precipitate or powder which was formed, and he found that the substance thus precipitated from lime water, by the air in which the diamond had been evaporated, effervesced on treatment with acid, and gave what was then known as fixed air, but which we now know as carbonic acid gas. Here, then, in his last experiment he completes his proof, showing that exactly the same effects are observed when charcoal is experimented upon instead of diamond. Lavoisier had now run his quarry to earth; he had determined exactly what it is that is formed when a diamond is burned. He has shown that a diamond when burned produces exactly the same substance that is produced when common charcoal is burned, and he, therefore, legitimately concludes that diamond is only another form of the element carbon. The reason that the diamond did not burn in the furnace when surrounded by a mass of charcoal was that the air, or rather the oxygen of the air, could not get to the diamond, because it was kept off by the charcoal, which burned instead of the diamond.—*Professor Roscoe.*

The Avoidance of Colds.

This is the season when coughs and colds are most frequent, and when by lack of proper care slight attacks often increase to serious ailments. The following sound suggestions by Dr. Dobell, in his excellent work on "Coughs, Consumption, and Diet in Disease" are therefore of timely importance:

"But 72 per cent," says the writer, "of the cases of winter cough, which I have analyzed, might probably have been prevented by attention to commonplace things. Let us then give a few minutes to their consideration. 1. Sudden changes of temperature.

"This is the most difficult to avoid of any on the list. The occupations and amusements of all classes involve such changes, and we cannot stop these occupations and amusements, even were it desirable to do so. But very much could be done to prevent the body from feeling these changes. The first and most important is the complete envelopment of the body and limbs in wool next the skin, thus interposing a bad conductor of heat between the surface of the body and

the outer air. It is surprising that even in the present day this simple and common sense protection is neglected by so large a number of persons, both of the educated and of the uneducated classes. It is not sufficient for the purpose in view that a little body vest should be worn, just big enough to cover the thorax and abdomen, leaving all the extremities unprotected. It should be insisted upon by medical men that the arms and legs require to be protected from the sudden transitions of temperature, as well as the trunk.

"The main source of protection, then, against sudden changes of temperature to the surface of the body, is to be found in a complete covering of wool next the skin. But, besides this, a much greater attention than is common should be paid to putting on and taking off complete and efficient overclothing, on going from hot to cold and from cold to hot temperatures. This is particularly neglected by the working classes, and by girls and boys at schools.

"What I have said with regard to sudden changes of temperature will apply equally to two other causes of fresh colds, namely, draughts of cold air, and cold winds. Both are to be deprived of their sting by proper clothing of the skin and mucous orifices.

"Getting wet, and wet feet, occupy a very serious place in our list; and there is no doubt that damp and cold applied to the general surface is the most efficient means of producing chill and vital depression, with congestion of the internal organs. It is necessary that cold be combined with moisture to produce this effect. Even if all the clothes on the body are wet, no harm will come so long as they are kept warm; and this suggests the very great value, to all persons liable to exposure to wet, of light waterproof overalls. They may either be put on to keep the under clothing dry; or if the under clothing has become wet, either by weather or by perspiration, they may be put on to prevent too rapid evaporation and consequent reduction of temperature, especially when the person is about to remain still after getting warm with exercise. In this variable climate, therefore, schoolgirls, governesses, shop and factory girls, and all women whose occupations call upon them to brave the weather, ought to carry with them complete waterproof mantles, made as light as possible, but extending from the neck to the ankles, which can be put on or not as required; and boys and men, similarly exposed, should carry waterproof overalls.

"But if wet and cold to the surface of the body is a fruitful source of catarrh, wet feet—which means wet and cold feet—is a still more prolific source. There is no external influence which so surely produces congestion of the naso-pulmonary mucous membrane as wet and cold to the soles of the feet. There is nothing so universally neglected, and yet there is nothing more easy to avoid. Warm socks, horsehair soles, goloshes, provide efficient protection against wet and cold feet. It does not seem to be half enough understood that, although a shoe or boot may not be wet through, if the sole is damp it will by evaporation most effectually conduct away the heat from the sole of the foot, and therefore ought never to be worn after exercise is over.

"We have still one item left on our list—namely, fogs and damp air. I have particularly remarked, that although the smoke and other irritating matters constituting fog are unquestionably very injurious, it is the moisture and cold of the fog which are the qualities most potent for mischief to the naso-pulmonary mucous tract. There is but one means of depriving a fog or mist of its injurious properties, and that is a respirator; and the same may be said of the changes of temperature, of which I spoke just now; a respirator is the only means of protecting the respiratory passages from the effects of transitions of temperature. It would be difficult to over-estimate the value of efficient respirators, as a means of protection against naso-pulmonary catarrhs, if persons disposed to these affections would only carry respirators about with them in their pockets, ready to put on if required at a moment's notice.

"Although it is quite proper to cover the neck lightly, I am decidedly of opinion that warm wrappers round the neck are objectionable; they produce congestion of the nasal and faucial mucous membrane, and thus dispose to the very complaints they are supposed to prevent. On what possible grounds people justify the sudden transition from a hot sitting room to a wretchedly cold bed room, which may not have had a fire in it for weeks or months, it is impossible to say; but it is quite certain that the absurd neglect of proper warming in bed rooms is a fruitful source of all forms of catarrh. We cannot too much impress this upon our patients. It may often be almost as necessary for a delicate person to put on a respirator on going up to bed as when going out of doors, unless proper precautions are taken to assimilate the temperature of the sleeping room with that of the sitting room.

"Such, then, are the principal means by which I would attempt to defeat the fickleness of climate. They all assume that the patient suffering from winter cough is to lead an active and an out-of-door life—not to be confined to his bed room, or his sitting room, or even to his house."

American Beef in England.

A correspondent of one of the English journals writes as follows in regard to the American beef recently received in London and other cities:

"A novel feature at this year's market was the introduction of American cattle, and the American breeders are to be congratulated on the result of their initial effort. Their consignments were none the worse for their long journey, and

we doubt not the experiment will be followed up in future years to a far larger extent, and with even greater success. * * * There is a sudden rage for American beef. A little while ago, when the weather was bad, American beef was selling at two cents a pound at Smithfield, and from ten cents to fourteen cents a pound at Birmingham. To-day I hear it has risen to the same price as English beef, and a well known West End butcher, whose customers are almost exclusively aristocratic, has purchased no beef but American. This looks as if Brother Jonathan were going to beat Brother John out of the field. If it has the effect of lowering the price of English beef I shall not grumble; but if fashion is going to run it up to the price of a luxury, I don't know that we shall be much better off after all."

[For the Scientific American.]

CHEMICAL PROGRESS IN 1876.

ORGANIC CHEMISTRY.

The immense field which organic chemistry opens for investigation is being assiduously tilled by a small army of chemists. It is, indeed, a tempting one, for the possibilities are great; in fact, nothing in it seems impossible of accomplishment. The number of possible compounds is infinite, and centuries will not exhaust the field of experiment. Synthetic chemistry is, perhaps, the most fascinating. The strides that it has taken since Wohler first prepared urea, and broke down that imaginary barrier, the idea that life was essential to the production of organic bodies, almost surpasses belief. At the Centennial Exhibition were exhibited many substances only recently obtained by synthesis and yet articles of commerce. About two years ago we heard with some distrust that the flavoring matter of the vanilla bean had been made from the sap of the pine tree; now it is a commercial article, cheaper if not better than the natural. Recently, other methods of preparing it have been devised, totally unlike that first discovered, and from different material. We refer to its preparation by Reimer from wood tar creosote, and from eugenol or eugenic acid (found in oil of cloves) by Erlenmeyer. Tiemann, the original discoverer of artificial vanillin, has made important contributions to our knowledge of the subject, having devised methods for the estimation of vanillin, determined the other constituents of vanilla beans, and made ethyl-vanillin, vanillic alcohol, coniferyl alcohol, and other compounds.

Another interesting case of synthesis is that of bitter almond oil, made from toluol by first subjecting it to the action of chlorine, when benzyl-chloride is produced, and then acting upon that with dilutenitric acid or nitrate of lead. Lippmann and Hawliczek, of Vienna, have recently subjected this artificial oil of bitter almonds to a series of careful tests, both chemical and physical, and proved its perfect identity in every particular, even in vapor density, with the genuine oil.

Phenol or carbolic acid continues to be the subject of numerous experiments; and Reimer and Tiemann have found that it may be converted into salicylic acid by heating its alkaline solution with tetrachloride of carbon. Para-oxybenzoic acid is produced at the same time. Kupferberg has succeeded in converting the last named acid into salicylic acid.

New methods of preparing alcohols and vegetable acids have been devised, and are curious from a theoretical point of view. Many attempts have been made to prepare the costly alkaloids, but as yet unsuccessfully, although in some cases these efforts have led to other discoveries of great importance.

The synthesis of indigo blue has been equally unsuccessful; the only method of its artificial production produces but a trace of it when the utmost care is expended upon it. The number of new dyestuffs is legion, and is daily increasing, so that none but a dye chemist may hope to keep up with the latest improvements in this direction. Coal tar products are the chief source of these dyes; but new dyes are occasionally produced from other materials, such as the sulphuretted organic dyes of Croissant and Bretonnière; and even ultramarine has come in for a fair share of attention. Eosine, one of the latest and most beautiful of the coal tar colors, has been the source of repeated experiments. R. Wagner has devised a method of detecting it on dyed fabrics by means of collodion; Waterhouse has investigated its photographic action, by mixing it with collodion, as Vogel had done with some other dyes. He found such collodion very sensitive to yellow and green; but on exposing it in the camera, the time of exposure was increased threefold. Bind-schedler and Busch state that Egli's method of making eosine by forming benzene-disulphonic acid, and then hydroxylating the compound, works well in practice. In all literature published on this subject, unfortunately, the most interesting details are carefully concealed, probably as trade secrets. The first step in the operation, says Durand, is to conduct benzol vapors into hot and concentrated sulphuric acid. The benzene-disulphonic acid formed is next converted into a lime salt, then into a soda salt, which is converted into resorcin by fusion with caustic soda. The resorcin is purified, and then fused with phthalic acid, which produces the fluorescence. To convert this into dibrom-fluorescence is the most difficult part of the operation; and it is on this point that we are left in the dark.

Aurantia is the name given to a new artificial dyestuff, which readily imparts to silk and wool a beautiful shade of orange. According to R. Gnehm, this dye is the ammonia salt of an acid discovered and named by him hexa-nitro-phenylamin. It possesses the remarkable and unfortunate property of irritating the skin of persons using it, causing an

eruption like that made by croton oil. Although some persons are not affected by it, it is not suited to general use.

A new series of dyestuffs, formed by the action of glycerin on phenol (carbolic acid) in the presence of sulphuric acid, has very recently been discovered by Reichl, of Prague, who is still at work on it. Both red and purple have been obtained in this way. He has also obtained dyestuffs by the action of glycerin on pyrogallol and on thymol, and purposes to study its action on cresol and other phenols. This opens a new field for study, and promises to prove the most important discovery of the year.

W. H. Perkin, the discoverer of the first aniline dye, is still finding new things in the color line. Among his recent papers is one on anthrapurpurin. Lauth has succeeded in preparing a new class of dyes by the introduction of sulphur into aromatic diamines, and then oxidizing the sulphur compound. It forms a beautiful purple. (See SCIENTIFIC AMERICAN, October 21, 1876.)

A natural dyestuff capable of forming lakes has been obtained by Mederstadt from the *musa fehi*, a plant of the banana family. Aniline black has attracted more attention than any other aniline color. Most of the experiments relate to the use of vanadium, which has almost entirely superseded copper, notwithstanding its price. One part only of vanadium salt is required for 50,000 parts of aniline oil.

In regard to the alkaloids, the principal work has been done by Drs. Wright and Beckett. Cahnberg gives some new reactions for codeine and atropine; Flueckiger, a new test for brucine; and De Vrij, a new reagent for quinine. Much has been done to aid the analyst in determining various alkaloids quantitatively too. The glucosides, the bitter principles, and the active constituents and essential oils of many plants have been sought and studied. Among the plants subjected to chemical investigation we have, first, the *eucalyptus globulus*, then *dulseamara solanum*, *vicia sativa*, and many others. Ergot has also been analyzed.

The subjects of food and drink have not been neglected, especially wine and milk. The adulterations of wine and the addition of artificial coloring matter is becoming so common abroad, where adulterations are not so tamely submitted to as here, that chemists are exhausting all their ingenuity to detect the falsifications, and with only partial success. Aniline colors are most easily detected by the power of dyeing silk or wool; but fruit and vegetable coloring matter is the most difficult of detection. The best paper on this subject is that of Gautier, who has constructed a series of tables of the reactions with various reagents. Dr. H. Vogel applies the spectroscope to them. Mellias has also written on the detection of colored red wines, and Bretet described a new method of detecting plastered wines.

The subject of the adulteration of milk is so often before the courts that the public are kept informed of all the latest investigations in that department; and it seems as if perfection had almost been attained in milk analysis. Not so with butter, however. The subject of artificial butter still agitates the public as well as the scientific mind. A pharmaceutical society in Leipzig offers a prize of 300 marks (about \$75) for a certain and practical method of testing cows' butter for adulteration with foreign fats. Competitors are required to send in their papers to B. Kohlmann, Leipzig-Rendnitz, before September 30, 1877. Water analysis is in an equally uncertain state, no satisfactory test for wholesome water having yet been devised; and the fight between Wanklyn and Frankland, about the albuminoid ammonia test, is still in progress.

DISINFECTANTS.

About disinfectants, a very great deal has been said and written. Carbon disulphide is one of the latest competitors in the field. Zöllner seems to have been the first to observe that mould never appeared in vessels containing a trace of carbon disulphide vapors. The poisonous nature of these vapors would lead us to expect that it would destroy germs of all sorts, and such seems to be the fact. Zöllner kept beef and veal for 32 days, at a temperature of 60° to 85° Fah., in an atmosphere containing this vapor. Hugo Schiff confirms these observations. Little that is new has been learned about salicylic acid, and doubts are entertained of its fulfilling the great expectations formed of it. Attention has been directed anew to borax and boracic acid as antiseptics. Thymol as an antiseptic has been described by Husemann.

ANALYSIS.

Analytical chemistry has not fallen behind in either the organic or inorganic branch. Gas analysis and volumetric analysis, or titration, have been subjects of thorough investigation. Many new substances have been introduced as indicators by acidimetry, in place of litmus, such as salicylate of iron, logwood, fluoresceine, eosine, and carmine. Grete proposes to use of xanthogenate of potassium for the quantitative determination of carbon disulphide, copper salts, and caustic alkalies in the presence of alkaline carbonates. Kopfer recommends the use of platinum for the ultimate analysis of organic substances. Other new methods of analysis, equally interesting to the analyst, are to be found in journals devoted to that branch of the science.

The above imperfect sketch of the doings of chemists in our Centennial year sustains the assertion with which we set out, that there is something new under the sun.

E. J. H.

CAST iron should be painted directly after leaving the mould, in order to preserve the hard skin which is formed upon the surface of the metal by the fusing of the sand in which it is cast.

[For the Scientific American.]

ŒDEMA GLOTTIDIS.

When a great or good man dies of an obscure disease, new incentives are added to the study of its nature and rational treatment. Previous to the year 1799, the clinical history of *œdema glottidis* had been loosely described by Morgagni and by Bichat; but of the pathological condition, giving rise so suddenly and insidiously to fatal results, but little if anything was known.

General Washington, with the exception of a slight cold for the day or two last past, was in the enjoyment of an ordinary degree of health. Suddenly, and without warning, he was seized with difficulty in breathing; and ere the danger was fully realized, the narrow slot in the respiratory track was closed up, and the nation was startled by the announcement: "Washington is dead!" An autopsy was had, which revealed an œdematous condition of the larynx and complete closure of the little space between the vocal chords; and since the 14th of December, 1799, the medical profession of the whole world has been more familiar with the pathology and rational treatment of *œdema glottidis*.

The immediate cause of death is suffocation from closure of the slit or space between the vocal chords (the *rima glottidis*); and the remote cause is œdematous thickening or enlargement of the parts nearly adjacent to this narrow passage. It will therefore be observed that the thickening may be in the mucous covering of the vocal chords, or in the ventricular bands or false vocal chords; it may be in the covering of the arytenoid cartilage or commissure; it may be in the lip, cushion or body of the *epiglottis*; or it may extend to all of these simultaneously. Strictly speaking, however, œdematous thickening can take place only in tissues like the ary-epiglottidean folds, where areolar tissue is interposed between the mucous membrane and the fibrous or cartilaginous structures beneath: the thickening of mucous membrane, or of the arytenoid muscle, when found, being more dependent upon an inflammatory process. Practically, this distinction is not made, the term being applied to thickening of all laryngeal structures which, in the main, partake of an œdematous character. And within the confines of a narrow and unyielding cartilaginous box like the larynx, an amount of swelling, which in other parts of the body would be of the most trivial consequence, is productive of grave and fatal results. In some instances the whole larynx is involved, but generally the condition is limited to one or more parts of it. The disease may be idiopathic, as in the illustration given, or it may occur as a sequence of other diseases, springing, as it were, from ambush upon a patient well advanced in convalescence from an attack of laryngitis, whooping cough, measles, scarlatina, small pox, erysipelas, pulmonary catarrh, Bright's disease, or any other disease of which dropsies are among the *sequela*. It may be also traumatic, from mechanical injuries to the larynx, or from an attempt to swallow corrosive liquids.

The rational signs consist of difficulty in swallowing and of articulation, with hoarseness and ineffectual cough, a sense of constriction as from the presence of a foreign body within the larynx, difficulty in breathing, with a whistling or stridulous sound, and finally death from suffocation. The physical signs are: More or less enlargement at and above the thyroid prominence, and tenderness upon pressure in proportion to the extent of inflammatory complication. The uvula and tonsils are generally more or less enlarged, and the mucous membrane of the pharynx more or less infiltrated, and of a dusky red color in proportion as the disease is high in the larynx. Generally, by wiping the tongue so as to grasp it with a napkin to draw it well out, or by pressing the base of it well down, the enlarged epiglottis may be seen rising above its natural position, often depressed in the middle by a crease from before backward, and having a semi-transparent appearance. If the enlarged parts are too low to be seen in this way, and there is no laryngoscope at hand, the finger may be passed well down into the larynx, when the condition may be made out with considerable accuracy by the touch. This, however, is a hazardous proceeding, as the irritation may result in spasm and complete closure of the glottis.

The rational differential diagnosis of *œdema glottidis* is comparatively easy. There is more regularity in the increase or decline of symptoms than in spasm of the *glottis*, less pain and enlargement than in acute laryngitis, and more rapid development of symptoms than from the presence of an intralaryngeal tumor or abscess. The laryngoscope reveals to ocular inspection the true condition; and physical differential diagnosis is clear and decisive.

The demand for relief is generally too urgent to justify the delay required for the operation of topical applications. Besides the irritability of the muscles of the larynx, and the liability of local applications to provoke spasm, is a serious obstacle to their use. Among the remedies that have been used as such may be mentioned a solution of nitrate of silver, a solution of alum, and also of tannin. Dilutions of carbolic acid and of the *liquor persul. ferri* have been recommended. But when it is remembered that danger results from mechanical occlusion, consequent upon a sero-plastic effusion beneath the mucous membrane, the insufficiency of mere local applications is apparent. If the œdematous enlargement can be reached, as is generally the case, the parts should be freely scarified or incised with a long curved bistoury or hernia knife, as recommended by Dr. Buck, who devised an instrument especially for such use. Relief follows almost instantaneously upon the evacuation of the effusion. Professor Strohmeier advises the forcible rupture of the distended

membrane with the end of the finger, when it can be done without too great risk of strangulation. When Dr. Buck's plan, which is generally employed, cannot be satisfactorily performed, the last resort is either to produce an artificial larynx through the creco-thyroid membrane, or tracheotomy; and the prompt relief which almost invariably follows is among the most satisfactory rewards of the surgeon, patients frequently falling asleep after the first few inspirations through the artificial opening. The opening of the trachea, however, is not curative, but affords refuge from the immediate danger of suffocation, while the disease is being controlled by such measures as remove dropsies in other parts of the body. They should be in the main constitutional; and the fact that these cases often occur in those with impaired or broken down constitutions should never be lost sight of in their treatment. A. G. F.

ASTRONOMICAL NOTES.

OBSERVATORY OF VASSAR COLLEGE.

The computations and some of the observations in the following notes are from students in the astronomical department. The times of risings and settings of planets are approximate, but sufficiently accurate to enable an ordinary observer to find the object mentioned. M. M.

Positions of Planets for February, 1877.

Mercury.

Mercury, which was so beautiful in the evening twilight of January, has now moved on to a position west of the sun, and should be looked for in the morning.

On February 1, Mercury rises at 6h. 22m. A. M., and sets at 4h. 19m. P. M. On the 28th, Mercury rises at 5h. 41m. A. M., and sets at 3h. 30m. P. M.

Mercury will be best seen on the 20th, when it attains its greatest elongation from the sun.

Venus.

Venus, although approaching the sun in position, is still very brilliant in the morning, and can be well seen during the first half of February.

On February 1, Venus rises at 6h. 1m. A. M., and sets at 3h. 12m. P. M. On the 28th, Venus rises at 6h. 3m. A. M., and sets at 4h. 14m. P. M.

Mars.

On February 1, Mars rises at 3h. 18m. A. M., and sets at 0h. 30m. P. M. On February 28, Mars rises at 2h. 54m. A. M., and sets at 11h. 52m. A. M.

Mars can easily be recognized on the 28th by its nearness to Jupiter. Both planets are in the constellation *Sagittarius*, Mars being a little south of Jupiter.

Jupiter.

Jupiter is conspicuous now in the morning, but is so far south and rises so late as to give scarcely any time for observations before daylight.

On the 1st, Jupiter rises at 4h. 21m. A. M., and sets at 1h. 24m. P. M. On the 28th, Jupiter rises at 2h. 55m. A. M., and sets at 11h. 56m. A. M.

Saturn.

Saturn rises so late in the morning and sets so early in the evening that it can be seen for only a very short time after sunset.

On February 1, Saturn rises at 8h. 28m. A. M., and sets at 7h. 13m. P. M. On February 28, Saturn rises at 6h. 49m. A. M., and sets at 5h. 44m. P. M.

Uranus.

Uranus is better situated for observations, during February, than any other planet. It is in good northern declination. It rises about 6 P. M. on the 1st, comes to the meridian a few minutes before 1 A. M. of the next morning, and sets at 7h. 46m. A. M.; it can, therefore, be seen for more than 12 hours. On the 28th, Uranus rises at 4h. 7m. P. M., comes to meridian at 11 P. M., and sets at 5h. 57m. the next morning. Uranus rises before the bright star Regulus, and, when on the meridian, is 2° above it. A small telescope will show its disc, looking like a very small full moon.

Neptune.

Neptune rises February 1 at 10h. 36m. A. M., and sets at 11h. 54m. P. M. On the 28th, Neptune rises at 8h. 51m. A. M., and sets at 10h. 11m. P. M. But Neptune can be seen only with the aid of good telescopes. It is among the stars of *Cetus*.

Sun Spots.

The report is from December 18 to January 15 inclusive. The large spot mentioned in the last report was observed until December 23, moving regularly across the disc on account of the sun's motion on its axis. Owing to cloudy weather, it was not seen after that date. On January 4, a very faint spot was discovered, already considerably advanced on the eastern limb. On January 9, when the next observation was made, a pair of very faint spots was visible on the eastern limb, while this faint spot, first noticed on January 4, was now on the western limb. On January 12, neither the single spot nor the pair could be found. The picture of January 12 shows a large spot on the eastern limb, followed by two very small ones. On January 13, another large spot appeared, irregular in shape and surrounded by faculae. The photograph of January 14 shows a regular motion of these large spots; but one of the small ones, which were observed accompanying the spot first noticed on January 12, had disappeared.

These two remarkably large spots are still visible (January 17), and the one first seen on January 13 will remain on the disc for at least a week longer. It seems probable, from position and peculiarity of shape, that this is the same spot first seen on December 17.

Milk Testing in Holland.

At the last meeting of the American Association for the Advancement of Science, held in Buffalo, Professor Von Baumhover, delegate to the Centennial for Holland, gave an account of the milk adulteration question in the city of Amsterdam, where the lactometer is not relied upon; but a simple and quick method of chemical analysis, introduced by the Professor, is employed, and has been adopted by the city authorities. The method of Dr. Von Baumhover consists in an improvement on that first proposed by Brunner. The trouble commonly found in evaporating milk, in order to find the amount of solid ingredients in it, consists chiefly in the continual formation of a skin on its surface, which swells up from the vapors beneath, and the milk boils over. This is avoided by mixing a sample of the milk with pure, clean sand, placing the mixture on filtering paper, and heating the whole on a slab of porous stone. All that evaporates is water, and the quantity is shown by the loss in weight.

In good cows' milk, the solid ingredients amount on the average to 13 per cent; but as they may vary, 11½ per cent has been allowed as a minimum, corresponding to a loss by evaporation of water of 88½ per cent. If the loss in weight is more, the milk may be set down as watered or skimmed, or both, no matter what the lactometer test indicates. In order to find the amount of butter, the filtering paper and its contents are placed in a funnel, and ether poured on and allowed to percolate through; this removes all the butter, and the amount of the latter is found by allowing the ether to evaporate. As the amount of butter in cows' milk varies between 3¼ and 5 per cent, 3½ per cent may be adopted as a minimum; and milk having less butter than 3½ per cent, the inventor claims, may be set down as skimmed or watered, or both.

As the determination of the amount of water and butter in milk is simply sufficient to determine its value in a commercial and sanitary point of view, the tests for casein and milk sugar may be dispensed with. In the above explanation, we have only given the main points of the analyses without entering into the minute practical details, which it is necessary to understand in order to obtain fully reliable results. Professor Von Baumhover stated that the milk inspectors, after being properly instructed, can in this simple way make 20 or more analyses simultaneously and in a very short time. In Holland, it is customary to test only such samples as arouse suspicion by their transparent, watery appearance; and many kinds of milk thus examined are proved to be largely adulterated, notwithstanding that they stand the lactometer test.

NEW BOOKS AND PUBLICATIONS.

NOTES ON ASSAYING AND ASSAY SCHEMES. By P. de P. Ricketts, E. M., Ph. D., Instructor in the School of Mines, Columbia College, New York city. Price in cloth \$2.50, in paper \$2.00. New York city: Published by the Author, School of Mines, 50th street and Fourth avenue.

This book is especially designed to meet the wants of the practical miner and assayer, as well as to lay down a system for the guidance of the student and the professional analyst. The rules and directions are the result of long experience, many of them having been tested in the laboratory of Columbia College. Several processes and details, originated in the mines of the Great West, have been embodied in the work, and complete lists of apparatus and reagents are added.

THE ELECTRIC BATH, ITS MEDICAL USES, EFFECTS, AND APPLICANCES. By George M. Schweig, M. D., etc. Price \$1.00. New York city: G. P. Putnam's Sons, 182 Fifth avenue.

The writer of this little work treats the subject and his readers with great candor, admitting that his "failures" in treating patients "have been illustrative of the fact that the electric bath is no more a panacea for all ills than any other remedial agent. Applicable as it is to a great variety of pathological conditions, it meets with many where it is destined to have negative or at best imperfect results." He claims, however, that the book is the result of his own experience, and that it owes nothing to the labors of other practitioners. We commend it to sufferers who desire to try such remedies.

That very useful manual of reference, the *Public Ledger Almanac*, George W. Childs, publisher, Philadelphia, has appeared for the year 1877, and is presented gratis to every subscriber to the *Philadelphia Public Ledger*. It contains a carefully prepared calendar, a valuable article on the progress of Philadelphia during the past century, another on the Centennial Exposition, a chronology of notable events of the past year, and lists of the officials of the National and State governments, Supreme Court, Diplomatic Corps, etc. The page of proverbs contains a world of homely wisdom and good counsel epigrammatically expressed.

Recent American and Foreign Patents.**NEW MECHANICAL AND ENGINEERING INVENTIONS.****IMPROVED CARTRIDGE CRIMPER.**

Mordecai B. Massey, Huntington, Pa.—This little instrument is intended to answer a want which has not, the inventor says, been heretofore supplied satisfactorily. The device consists of a pair of pinchers with jaws formed to fit the shell, and a cylindrical tongue between them, over which tongue the shell is placed for crimping. This tongue has a slight depression in it, into which the jaws compress the shell; and the end of this tongue, on withdrawing the shell, serves as a gauge to show when it is sufficiently crimped. A shell which has been used with a heavy charge of powder is so much expanded that it will not hold the bullet, when reloaded, unless the mouth of the shell be somewhat reduced in size; and the shell must be reduced or crimped in such manner that it will hold the bullet with its center line from base to point exactly coinciding with the center line of the bore of the barrel. The bullet then starts straight and true. The inventor above named claims that his crimper answers the want exactly.

IMPROVED SAW SET.

George S. Grier, Milford, Del.—The object of this invention is to furnish a device for setting the teeth of saws of different sizes, which is capable of being so adjusted as to give much or little set to them, as may be desired. It consists of two hinged jaws provided with die plates having teeth to engage alternately with the teeth of the saw, between the lower portion of which jaws, beneath the hinge, a double cam is placed, for closing or opening them, the said cam being operated by a lever.

IMPROVED MEANS OF LESSENING DRAUGHT OF VESSELS.

Edward Ellison, San Francisco, Cal.—This invention consists in certain means for lessening the draught of vessels in moving through the water, and it consists in either constructing the vessel with inclined surfaces upon its bottom, or in applying to the bottom or the sides of it inclined plates which will tend to lift the vessel in the water as it moves through it, thereby lessening the draught.

IMPROVED COMBINATION LOCK.

George Winter, Jacksonville, Va.—The present invention is an improvement upon that for which the same party received letters patent No. 181,756, dated August 29, 1876. The object of the invention is to produce a cheaper, more simple, compact, and secure lock.

IMPROVED VALVE GEAR.

Wilberforce Johnson, Camden, N. J.—The object of this invention is to provide a simple, effective, and valuable valve gear, which shall be regulated at will for the admission of steam to the cylinders, the stopping and reversing of the engine, and which shall have separate devices for controlling the "lead" for greater or less speed. To this end the devices are located upon a drive shaft, which may be either a part of the running mechanism of a stationary or marine engine, or the axle of the car wheels when applied to a locomotive. These devices consist in the main of a central loose sleeve encompassing the shaft and connected by diametrical pivots to a transverse encompassing collar. This collar is geared to the shaft and made to revolve through the devices for controlling the "lead," and is oscillated by a pitman arranged longitudinally with a drive shaft and geared with it rigidly at one end, and to a sliding collar at the other. This oscillation is imparted to a rim which slides upon the periphery of the collar and imparts the proper motion to the valves through connecting rods.

IMPROVED RAILWAY CAR.

Samuel R. Wallace and Oliver V. Wallace, San Francisco, Cal.—The object of this invention is to obviate the sudden jolt and jar incident to railway cars in stopping and starting. In attaining the end of the invention the body of the car is located upon swinging supports which have spring seated bearings in the car frame, whereby the longitudinal jolt of the car is converted into a swinging upward movement of the body of the car and its contents, instead of having the effect of the impact and start imparted directly to the said car and contents.

IMPROVED FEATHERING PADDLE WHEEL.

Francis J. Leisen, Woodbridge, N. J.—This consists of a contrivance of stationary cams in a hollow hub, in which the bucket arms are fitted in boxes so as to revolve a quarter of a revolution forward and backward to present the buckets sidewise or edgewise. The essential feature of the invention is the contrivance of the hub.

IMPROVED ELEVATOR.

Stillman E. Chubbuck, Boston, Mass.—The invention relates—First, to the automatic mechanism employed for throwing the hoisting apparatus proper out of gear or arresting its operation when the ascending platform is overweighted, or when any object or material placed thereon comes in contact with the floors or timbers of a hatchway, so that the hoisting rope will not continue to be wound up, and so that no injury can result to persons on the elevator or the building in which it is located. Second, to the automatic mechanism employed for throwing the hoisting apparatus proper out of gear or arresting its operation whenever the said hoisting rope parts, or the platform is arrested in its descent, thereby preventing the rope continuing to unwind. Third, to the belt shifting mechanism proper and the arrangement of the driving worm shaft with two drums for winding and unwinding the hoisting rope.

IMPROVED FENCE.

Frederick Suiter, De Witt, Iowa.—Instead of wooden fences, which are costly and not durable, this inventor suggests an iron fence of very simple construction, which is at the same time strong and capable of being cheaply erected. A semicircular post that tapers upward and downward from a base plate at the point where it emerges from the ground. It is strengthened by a center rib or ridge. The fence wires are connected by staples, slots, and fastenings, and also intermediately between the posts to a stub post. The posts of the end panels are stiffened by a tubular diagonal brace, that is fitted by collars to the posts.

IMPROVED SNOW PLOW.

William Cooke, Morrisville, Vt., assignor to himself and Henry A. Buzzell, of same place.—This timely invention may be commended to the notice of railway companies, inasmuch as it aims to substitute for the large heavy snow plows now in use a much lighter and more manageable apparatus which will effectually keep tracks clear. It consists of a car with snow plows, hung in an adjustable manner to both ends, and operated by a suitable lever device. The plows are fitted with tips extending below the top of the rail. The track is cleared of ice by means of spring-acted concave cutters or knives, that are applied to a suitable frame, and raised or lowered by a lever. The plows swing readily on the eyebolts, and are so adjusted that when they come in contact with any frozen dirt or ice they will lift and run over it without breaking.

NEW AGRICULTURAL INVENTIONS.**IMPROVED DITCHING MACHINE.**

Daniel Hess, Greenville, Miss.—This invention is an improvement in the class of ditchers, having an endless belt or apron by which the earth is elevated and deposited upon a cross-belt or carrier. The improvement relates particularly to the construction and arrangement of devices for causing the machine to advance, to the form of the cutters, and also the mode of attaching them to the elevator belt or apron.

IMPROVED CHURN.

James S. Smith, Beebe Station, Ark.—This invention is an improvement in the class of churns having a vertical rotating dasher. The improvement relates first to the construction and arrangement of parts whereby the dasher shaft and its operating gear are adapted for convenient removal from their bearings. The invention also relates to the construction of the top or cover of the tub or churn-body, in two like-sized parts, which are connected by a hinge and elastic strap, to adapt the cover for convenient application to and removal from the tub.

NEW MISCELLANEOUS INVENTIONS.**IMPROVED ARTIFICIAL LEECH.**

Floyd F. McDonald, Blacksburg, Va.—This invention relates to that class of medical instruments intended to subserve the purpose of the natural leech and extract blood from some portion of the human body. It consists in an artificial leech produced by combining an elastic bulb open at the upper end, a T tube open at its three ends, a small tube open at one end only, and a suitably constructed knife. The bulb is first compressed and the open end held firmly against the body; the bulb is then allowed to expand and form a vacuum which draws the skin upward; the knife then makes a puncture in the skin, and the blood flows until the requisite quantity has been drawn.

IMPROVED MEDICAL COMPOUND.

Miss Judie D. Lipscomb, Andrews, Va.—This compound, known as the "chill master," is a specific for fever and ague, consisting of an infusion of tulip tree bark (*Liriodendron*), willow bark (*salix*), flux root (*gentiana Catesbaei*), with cherry bark (*prunus Virginiana*), dogwood bark (*cornus Florida*), sassafras (*sassafras*), flowering almond (*prunus amygdalus*), sulphate of quinia, Fowler's solution of arsenic, and whiskey in the proportions specified; and it is said to be very efficacious for the purpose.

IMPROVED INDEXER.

John Suter, New York city.—This device is made of one piece of sheet metal, and consists mainly of a strip or plate designed to be inserted between the leaves of a book to indicate where an extract is to be made, or reading resumed, etc. The broad end of this strip or plate is bent in such manner as to form a clamp for holding slips containing memoranda, notes, etc., against the back of the book.

IMPROVED FIRE EXTINGUISHER FOR VESSELS, ETC.

Almon M. Granger, New Orleans, La.—This invention relates to certain improvements in chemical fire extinguishers, designed more particularly for harbor fire protection boats and sea-going vessels, but applicable also in most of its features to general use. The general principle of the improvement rests in the direct use of the dry gaseous carbonic acid in smothering volume, in contradistinction to the common use of a limited quantity of the same dissolved in water under pressure. The means for carrying out the invention consist generally in the combination of a set of capacious generators for containing bicarbonate of soda, a set of superposed acid vessels, a subjacent acid reservoir, and an air pump, or equivalent forcing apparatus for charging the acid vessels from the reservoir, the whole being combined, by means of communicating pipes controlled by valves or socks, so that the acid may be forced from the reservoir in the hold of the boat only when the effective power of the gas is required, and whereby accidental admixture of the chemicals is from the motion of the vessels, or from other causes, completely avoided. This apparatus embodies many novel details of construction, and from practical experiments upon a large scale conducted on board the New Orleans Harbor Protection Boat, promises to supply a want which the loss of life and property on the sea has made long felt.

IMPROVED PAPER BAG.

James H. Percy, Cumberland, Md.—This is a paper bag provided with strings permanently attached to its sides in such positions as to come together when the mouth of the bag is turned or folded down.

IMPROVED LETTER BOX.

Joseph Katz, New York city.—This letter box indicates automatically the time at which the mail is to be collected; and the invention consists of a swinging door or drop, which must be opened to collect the contents of the box that is hinged, and provided with teeth at the free end, that engage similar teeth of a roller that operates, by a pawl and ratchet device, the time-indicating disk.

IMPROVED PANTALOONS CONFORMATOR.

John G. W. Feldmann, New York city.—Pantaloons cutting is by some tailors adopted as a specialty—and they charge, as a rule, large prices for their neatly fitting garments. Mr. Feldmann here presents an invention which will enable any one, he says, to cut trousers to a perfect fit, the apparatus being analogous to the conformators used by hatters in measuring the head. The device consists of a frame of the size and general shape of the leg, with a number of spring-acted adjustable set pieces that bear on the leg, and mark, by pins passing through recesses of the main frame, the exact shape of the leg on a pattern paper applied to a detachable marking frame. The latter is supported by a foot part and forced against the marking pins, releasing a suitable spring mechanism. A center waist rule and tape line at the top part serve to take other measures.

IMPROVED UMBRELLA SUPPORT AND ROBE HOLDER.

William Rounds, Chester, Vt.—Knowing how difficult it is to hold up a lap robe or boot, an umbrella beside, and to manage the reins at the same time, this inventor proposes an ingenious device for relieving the driver of the care of the two articles first mentioned. To sustain both robe and umbrella, he attaches to the carriage seat a plate, which is provided with dovetail grooves for supporting a standard, to which a holding device is secured, in which an umbrella stock may be clamped and adjusted to any desired angle on a horizontal or vertical plane. The said standard is clamped in the grooves in the plate by an eccentric, and is bent into a U-shaped loop, the open end of which is inclined downward toward the front of the carriage for receiving the lap robe or boot, which is retained by a suitable clamping device.

IMPROVED BRICK KILN.

Holland B. Evans, St. Charles, Mo.—This inventor has devised a useful improvement in the construction of the brick kiln, patented, jointly, to himself and Ernest G. Kemper, November 9, 1875. A number of permanent corner and side flues are arranged to run from the bottom and arches to the top of the main part of the kiln, and then under the different compartments to the uppermost compartment, and out at the highest point of the same. A series of shorter flues at the top of the main part and compartments of the kiln are closed in suitable manner, as required to adjust the heat in the kiln. The permanent flues secure thus a constant supply of heat at the top part of the kiln while the short temporary flues, distributed over the top of the kiln and compartments, serve to regulate the heat and give complete control over the kiln during the process of burning the bricks.

NEW HOUSEHOLD INVENTIONS.**IMPROVED MEAT CHOPPER.**

Hugh P. Rankin, Allegheny, Pa.—This invention relates to certain improvements in that class of meat choppers in which a series of cutters are successively lifted by a shaft provided with cams, and allowed to chop the meat upon a rotating table from the tension of separate springs which force the cutters downwardly when the cams leave the lift bars carrying the cutters. The improvement consists principally in the means for regulating the downward stroke of the knives to prevent them from rapidly chopping up and wearing out the wooden table.

IMPROVED PORTABLE FIREPLACE.

Theodore C. Nativel, San Francisco, Cal.—This invention relates to a novel construction of portable fireplace designed to be used with an improved form of chimney stack which requires no earth foundation, for which letters patent were granted the same inventor, October 5, 1875. The portable fireplace is so constructed as to fit in the corner, or any other portion of the room, and is constructed preferably of fire clay with arrangements for ventilation, and for preventing the burning of the woodwork of the building.

NEW WOODWORKING AND HOUSE AND CARRIAGE BUILDING INVENTIONS.**IMPROVED COMBINED SLED AND TRUCK.**

Sylvanus F. Brooks, Cambridgeport, Mass.—This consists of a truck body having runners, with semi-circular recesses on one side, and wheels that extend into the recesses of the runners and above the body at the other side. Projecting side strips support a detachable frame on the body, whether the same is used on runners or wheels. The device may be used as a toy vehicle for the amusement of children, being quickly changed to a sled or truck, as desired.

IMPROVED MACHINE FOR SHAPING PLOW HANDLES.

Edmund A. Conner, Metropolis, Ill.—This is an apparatus for guiding plow handles and other articles while being shaped; and it consists of a frame attached to the side of a shaping machine, which is capable of being moved vertically by a suitable lever, and which is provided with pins, upon which moves a guide having cam slots of the form desired in the article to be shaped, the article being clamped to the guide, and moved up to the cutters by a lever connected with the guide.

Business and Personal.

The Charge for Insertion under this head is One Dollar a line for each insertion. If the Notice exceeds four lines, One Dollar and a Half per line will be charged.

Agricultural Implements and Industrial Machinery for export and domestic use. R. H. Allen & Co., N. Y.

Skinner Portable Engine Improved, 2 1-2 to 10 H. P. Skinner & Wood, Erie, Pa.

For Sale—Half interest in Foundry and Machine Shop. Machinist preferred. A. W. Maxwell, Knightstown, Ind.

Yacht and Stationary Engines, 2 to 20 H. P. The best for the price. N. W. Twiss, New Haven, Conn.

Wanted—A complete set of Patent Office Reports. Address, with price, P. O. Box 3,700, New York city.

Pattern Makers can get Metallic Pattern Letters, to letter patterns, of H. W. Knight, Seneca Falls, N. Y.

Scientific American, 34 vols. (2 to 35) for sale cheap. J. D. Rice, 923 Race St., Philadelphia.

Wanted.—Good second hand Back Geared Screw Cutting Foot or Bench Lathe. P. O. Box 303, Amsterdam, N. Y.

Lightning Screw Plates. A perfect thread at one cut adjustable for wear. Frasse & Co., 62 Chatham St., N. Y.

More than Ten Thousand Crank Shafts made by Chester Steel Castings Co., now running; 8 years' constant use prove them stronger and more durable than wrought iron. See advertisement, page 78.

Metallic Letters and Figures to put on patterns of castings, all sizes. H. W. Knight, Seneca Falls, N. Y.

Split-Pulleys and Split-Collars of same price, strength and appearance as Whole-Pulleys and Whole-Collars. Yocom & Son, Drinker st., below 147 North Second st., Philadelphia, Pa.

Emery Grinders, Emery Wheels, Best and Cheapest. Awarded Medal and Diploma by Centennial Commission. Address American Twist Drill Co., Woonsocket, R. I.

Patent Scroll and Band Saws, best and cheapest in use. Cordesman, Egan & Co., Cincinnati, Ohio.

To Clean Boiler Tubes—Use National Steel Tube Cleaner, tempered and strong. Chalmers Spence Co., N. Y.

D. Frisbie & Co. manufacture the Friction Pulley—Captain—best in the World. New Haven, Conn.

Wire Needle Pointer, W. Crabb, Newark, N. J.

Send for circular of Brass Hydraulic Engine for blowing organs. Hilbourne L. Roosevelt, Church Organs, New York.

Power & Foot Presses, Ferracute Co., Bridgeton, N. J.

Magic Lanterns and Stereopticons for Parlor Entertainments and Public Exhibitions. Pays well on small capital. 74 page catalogue free. Centennial Medal and Diploma awarded. McAllister, 49 Nassau St., N. Y.

Superior Lace Leather, all sizes, cheap. Hooks and Couplings for flat and round Belts. Send for catalogue. C. W. Arny, 148 North 3d St., Philadelphia, Pa.

F. C. Beach & Co., makers of the Tom Thumb Telegraph and other electrical machines, have removed to 530 Water St., N. Y.

For Best Presses, Dies, and Fruit Can Tools, Bliss & Williams, cor. of Plymouth and Jay Sts., Brooklyn, N. Y.

Water, Gas, and Steam Pipe, Wrought Iron. Send for prices. Bailey, Farrell & Co., Pittsburg, Pa.

Diamond Tools—J. Dickinson, 64 Nassau St., N. Y.

Hydraulic Presses and Jacks, new and second hand. Lathes and Machinery for Polishing and Buffing metals. E. Lyon, 470 Grand St., N. Y.

Solid Emery Vulcanite Wheels—The Solid Original Emery Wheel—other kinds imitations and inferior. Caution—Our name is stamped in full on all our best Standard Belting, Packing, and Hose. Buy that only. The best is the cheapest. New York Belting and Packing Company, 37 and 38 Park Row, New York.

Steel Castings from one lb. to five thousand lbs. Invaluable for strength and durability. Circulars free. Pittsburgh Steel Casting Co., Pittsburgh, Pa.

M. Shaw, Manufacturer of Insulated Wire for galvanic and telegraph purposes, &c., 259 W. 27th St., N. Y.

Shingle, Heading, and Stave Machine. See advertisement of Trevor & Co., Lockport, N. Y.

For Solid Wrought Iron Beams, etc., see advertisement. Address Union Iron Mills, Pittsburg, Pa., for lithograph, etc.

Articles in Light Metal Work, Fine Castings in Brass, Malleable Iron, &c., Japanning, Tinning, Galvanizing. Welles Specialty Works, Chicago, Ill.

Boosey's Cheap Music and Music Books. Full Catalogues free by mail. Boosey & Co., 32 East 14th St., New York.

For Sale—Two sets Hydraulic Presses, 10 inch cylinder, 2 foot lift, 100 tons pressure, 5 inch one set, 4 inch other. In good order. P. O. Box 3396, Boston, Mass.



E. L. C. can fasten cloth to brass by following the directions given on p. 101, vol. 34.—C. H. E. will find directions for making manifold paper, for writing in duplicate or triplicate, on p. 154, vol. 30. It is a well known device.—A. C. will find directions for drilling glass on p. 218, vol. 31. As to soldering silver, see p. 251, vol. 28.—C. is informed that peroxide of manganese is sold in the market, packed in barrels containing about 800 lbs. each.—J. B. will find directions for separating platinum from gold on p. 409, vol. 35.—F. S. C. will find directions for French polishing on p. 11, vol. 32.—G. O. will find directions for preparing skeletons of animals on p. 75, vol. 28.—D. W. will find the desired information as to the transit of Venus on p. 180, vol. 32.—B. B. T. should state what method he employs, and what ore of nickel.—J. G. S. will find directions for bluing steel on p. 123, vol. 31. For polishing shirt bosoms, etc., see p. 213, vol. 34.—W. L. L. will find directions for silvering mirrors on p. 267, vol. 31.—J. N. will find something on the use of petroleum in boilers on p. 164, vol. 30.—C. V. L. will find a recipe for an aquarium cement on p. 202, vol. 28.—W. M. B. will find a description of the photo-engraving process, which is probably the one he enquires about, on p. 272, vol. 32.—E. D. L. will find the dimensions of the Birmingham wire gauge on p. 233, vol. 28.—J. J. should use rubber varnish on his cotton cloth. See p. 11, vol. 32.—J. M. will find on p. 151,

vol. 30, directions for nickel plating.—T. R. S. will find a recipe for a washing fluid on p. 27, vol. 34.—B. B. C. will find a good recipe for shoe blacking on p. 27, vol. 34.—C. A. M. will find directions for making an electric machine on p. 266, vol. 34.—T. J. M. will find directions for making a barometer on p. 394, vol. 33.—J. S. will find directions for making paper stick on tin on p. 362, vol. 36.—C. A. H. will find a description of toughened glass on p. 402, vol. 32.—B. S. will find a recipe for varnish for patterns on p. 409, vol. 33.—W. A. H. will find directions for making rubber stamps on p. 155, vol. 31.—R. T. W. will find something on hardening copper on p. 123, vol. 32.—E. J. will find directions for hardening rubber on p. 203, vol. 35.—C. I. H. will find full descriptions of air brakes on p. 289, vol. 34.—H. W. will find a recipe for white ink on p. 268, vol. 33.—R. C. will find directions for tempering steel on p. 122, vol. 30.—T. F. M. will find directions for making root beer on p. 170, vol. 27.—J. L. P. will find rules for calculating the proportions of gear wheels on screw-cutting lathes on p. 107, vol. 34.—C. D. will find directions for repairing sheet rubber goods on p. 155, vol. 26.—W. F. P. will find directions for moulding rubber on p. 283, vol. 29.—J. B. C. will find directions for making parlor matches on p. 75, vol. 29.—J. C. M. will find a recipe for a black walnut stain on p. 90, vol. 32.

(1) A. I. says: I have been told by a great many men who pretended to know, that a gun would recoil or kick much more violently if the shot or ball is not close down to the powder. I experimented with a gun barrel some time since, leaving 1 1/2 inches or more space between shot and powder, and found the recoil to be very much less than when the shot was rammed solid down. I laid the barrel on a plank and measured the distance of the recoil at each fire. I used only a barrel of a gun and fired it by a slow match, so it was free to move. A. Your experience is contrary to that of many a sportsman, who is sometimes forcibly reminded that he did not ram the charge home by getting a "kick" from the gun on his shoulder.

(2) J. S., of Brussels, Belgium, asks: 1. Can the ratio of expansion be changed in any high pressure engine that has not a variable expansion cut-off? A. It cannot be changed without making some alteration in the valve gear. Your engine should have the valve set to cut off the steam at about 3/4 of the stroke. 2. What is the formula for the quantity of water in cubic feet to be evaporated for an engine? A. Allow from 40 to 45 lbs. per horse power. 3. Would the crushing force between rollers be the same under two different speeds of the engine, not per hour, but at a given moment? A. Yes. 4. Is there any rule or formula to calculate the intensity of the crushing force between the rollers? A. It can be calculated approximately by the relative distances travelled by piston and roller respectively in a given time, making deductions for friction of the parts. 5. What will be the best ratio of expansion if the engine runs at 25 revolutions per minute? A. The same as before, supposing that you refer to getting the most power out of the engine.

(3) M. H. P. asks: 1. What percentage of nourishment does butter, beef, and beans respectively contain? A. The ratio of nitrogenous or flesh-producing material in each is approximately as follows: Beef 25, beans 9, butter (pure) none. 2. Why is it that the tables, showing percentage of nourishment in food, by different authorities, differ so greatly? A. That differences do occur in tables of this kind, and principally in the figures given for animal food, is because of the non-homogeneity of such material, and the arbitrary methods of selecting the materials for determinations. The best results are, therefore, only approximate.

(4) A. P. B. says: I have a vulcanized rubber bath tub, which I have used till the rubber has become soft, and is now quite gummy and cracked. Is there any remedy for it? A. We do not know of a practical remedy for this. The interior surface may be somewhat improved by coating with a varnish made by dissolving equal parts of caoutchouc and gutta percha in hot naphtha or bisulphide of carbon; such varnish is sold in the market.

(5) A. J. and others ask: How can we make a good varnish for patterns? A. Use shellac varnish with just enough fine lampblack to color it. Do not apply the varnish too thick. It is not hygroscopic. Tap the pattern gently at different points before attempting to remove it from the sand. If your sand does not work well, dust the pattern over with fine blacklead, as it lies in the flask, preparatory to packing the sand.

(6) L. S. W. says, in reply to J. B. C., who asks for a demonstration of the following theorem: If tangents be drawn to 3 circles of unequal diameters, the points of intersection of the tangents are in a straight line. The best demonstration and the most rapid one is based on analytical geometry. If I can prove that (1), (2), (3) are in a straight line, the theorem is demonstrated: Let r, r', r'' be the radii of the 3 circles. The co-ordinates of (1) and (2) are:

(1) x = (r'r'' - a'r') / (r'r'' - r'a'), y = (r'r'' - b'r') / (r'r'' - r'a')

Equation of the straight line passing at (1) and (2) is: { r(b' - b'') + r''(b' - b) + r''(b - b') } x - { r'(a' - a'') + r''(a' - a) + r''(a - a') } y + r'(a'a'' - b'b'') + r''(a'a' - b'b') + r''(a'a - b'b) = 0. The symmetry of this equation sufficiently shows that the line it represents must pass through (3).

The latter has for co-ordinates: { x = (r'a'' - r'a') / (r'a'' - r'a'), y = (r'b'' - r'b') / (r'a'' - r'a')

Remarks: The points (1), (2), (3) are called "centers of similitude." The line, D E, is the axis of similitude.

(7) J. P. M. asks: 1. If I have a glass tube 3/4 of an inch in diameter, with a bulb on its end 2 inches in diameter, and an airtight piston working in the tube, what force would it exert by heating from 60° to 104° Fah.? A. If air is employed, as the original pressure or volume is multiplied in a definite ratio by a given change of temperature, if it is greatly compressed, the change when it is heated will be proportionately large.

2. Would it be any more if filled with mercury or with compressed air? A. The tension of mercury vapor under this change of temperature would be very slight, and much less than in the case of compressed air.

(8) C. S. asks: What is oil of bay rum made from? A. Bay rum is obtained by distilling rum with the leaves of myrcia acris, sometimes called the bayberry. The tree is a native of Jamaica and other West India islands.

(9) O. A. S. asks: How is hop extract made? A. Tincture of hops is made by taking 5 troy ozs. hops in powder, and a sufficient quantity of diluted alcohol. Moisten the powder with 2 ozs. of the alcohol, pack in a cylindrical percolator, and pour diluted alcohol on till 2 pints tincture are obtained.

(10) J. C. D. asks: What is the best varnish for varnishing a drawing made in India ink with heavy lines and parts, which have been tinted with various colors? A. Put a drop or two of acetic acid in the ink; and when the drawing is dry, varnish with mastic varnish.

(11) C. V. P. asks: How can I stain the grain side of a calf skin a permanent black? This leather contains oil, and the stain must have something alkaline, alcoholic, or acid to make it bite in. A. First rub well with a strong aqueous solution of proto-sulphate of iron, and then with a concentrated solution of extract of logwood.

(12) H. B. B. asks: How can I make a dark blue ink with gunpowder? A. Make a strong solution of the gunpowder in warm water containing gum arabic, and add a sufficient quantity of sulphate of indigo (in digo carmine) to produce the desired tint.

(13) B. F. B. asks: How can I cure chilblains? A. The following treatment has given general satisfaction: Melt together in a suitable vessel 3 ozs. beeswax, 3 ozs. Venice turpentine, 8 ozs. lard, and 1 pint sweet oil. Stir these well together and raise the temperature till the mixture simmers; then allow to cool. This should be applied to the feet on a piece of cloth when going to bed. A sure protection against this irritating ailment is found in good, dry, woollen clothing for the feet.

(14) J. C. C. asks: 1. Is there any electric current or power in the so-called electric belts and bands? A. Yes. 2. Is there any power in a belt made of alternate discs of zinc and silver, wetted in vinegar once a day, to be worn around the body to create an electrical current for the cure of pain, etc.? A. Yes, but such currents are very weak.

(15) G. W. S. says: I am using an oxyhydrogen gas machine for burning sheet lead together. I make the hydrogen by using commercial sulphuric acid 1 part, water 7 parts, and granulated zinc. It melts the lead well enough on flat seams; but on upright work the lead seems to tarnish and will not unite together. I use chemically pure muriatic acid as a flux. A. Use a saturated solution (in water) of sal ammoniac (chloride of ammonium) instead of the acid, and the inner cone of the flame—not the extreme tip—which oxidizes the metals rapidly. The operation should be performed as rapidly as possible. Your jet, being fed with air, which contains only about 1/5 part oxygen, is not an oxyhydrogen jet, but a blast lamp. The general arrangement of your hydrogen generator is correct.

(16) J. E. asks: How is solder applied in the manufacture of tinware, so as to make it adhere, and lay evenly on the surface of the tin? A. Use, in conjunction with the solder, hydrochloric acid in which has been dissolved all the pure zinc it will take.

(17) F. L. asks: Is there any mixture with which I can color an alloy of block tin and lead to a copper color? A. A lacquer composed of thin shellac varnish colored with turmeric and dragon's blood is sometimes used for this purpose. A thin electrolytic deposit of copper gives much more satisfactory results.

(18) H. P. S. says: In reply to A. A. A., who asks what wood is best for the top of a violin: The tops of all good violins are of spruce, with fine, straight grain. Backs are curled maple, the grain in short, fine waves, not wild, as it is termed. Shellac varnish is worthless, and worse, on a violin. Two kinds of varnish may be used, namely: 1. Best coach oil varnish (a light coat, with long time to dry). 2. The old Cremona varnish, the basis of which is the rare gum amber. If this varnish is used, no other coloring will be necessary, as the varnish gives a beautiful amber color, though deeper stains may be used if desirable. The varnish is not in the market; but if A. A. A. will address the initials as above, at Syracuse, N. Y., I will give him particulars regarding it.

(19) H. T. D. asks: 1. How can I get a good deposit of iron from its sulphate, or any solution that may be preferable? I have succeeded in getting only a black powder from a sulphate solution. I think I can utilize a good deposit of iron. A. Use a very strong solution of the proto-sulphate in an aqueous solution of chloride of ammonia. The anode should be moderately large and of good wrought iron. Use one large Smee cell (carbon zinc, 1 quantity). The current should be strong and constant, but in no case strong enough to decompose water. The bath must be as nearly neutral as possible, and the surface of the cathode perfectly clean; this is the greatest source of the difficulty. The connections should all be made before the cathode is placed in the bath. 2. In Napier's "Electro-Metallurgy" there are some remarks upon depositing alloys. Would the carbonate of ammonia and cyanide of potassium solution, spoken of, answer for an alloy of equal part of tin and copper? A. Yes.

(20) A. H. W. says: I send you a bottle containing a worm which troubles our well water. It is never seen in summer, and then the water is pure and quite cold. As soon as cold weather comes the worms come also; and then the water has a smell and seems warmer than in summer. Can you inform me of something, not injurious to health, that can be put in to clear the worms out? A. Test a small sample of the water by just tinting it with an aqueous solution of permanganate of potassa. If, after standing for a few hours, the tint

disappears, the water is unfit for drinking purposes. It is not advisable to add any chemical to the water; the best that can be done under the circumstances is to add a few frogs or tadpoles which feed upon the insects and worms, and purify the water. This method is an old one.

(21) R. L. asks: 1. To what degree of heat should coal be exposed to make illuminating gas in the most economical manner? A. About 2,300° Fah. 2. Would it be necessary to have the gas purified for heating purposes, and what would be the disadvantages of non-purified gas? A. The purpose of purification is principally to remove the carbonic acid gas, which greatly impairs both the heating and light, producing qualities of the gas, by obstructing its proper combustion. The gas will burn readily, however, without purification. 3. Have there ever been any successful attempts to generate coal gas with a small heating apparatus of about the capacity of an ordinary stove? A. With an iron retort and good fire, coal gas may be obtained in small quantities in the way you mention. The pipe leading from the retort should be of ample dimensions to prevent clogging, and the hot gas, as it comes over, should be thoroughly washed with cold water in order to remove the tar, coal oils, ammonia salts, etc., which come over with it. 4. Would the gas and coke burnt separately give out a smaller or larger amount of heat, than the quantity of coal wherefrom they are produced? A. The total amount expressed in foot-pounds would be the same in either case.

(22) W. J. T. says: I saw on each side of the sun a perpendicular rainbow-colored streak, about 15° in length, with the orange side toward the sun, and about 10° away. Thermometer +19, atmosphere hazy. What was the cause? A. This class of phenomena is caused by the refraction and decomposition of light by crystals of ice floating in the atmosphere, on the same principle as the prism produces the different colors.

MINERALS, ETC.—Specimens have been received from the following correspondents, and examined, with the result stated:

A. M.—It is galena (sulphide of lead) containing in 100 parts, 86.6 lead, 13.4 sulphur. It is the principal ore of lead worked.—R. & P.—It is a piece of amorphous quartz rock, somewhat discolored by sesquioxide of iron. There is a remote possibility that it may contain a small percentage of gold. This would necessitate a qualitative analysis.—A. H. K.—It contains sulphide of antimony, sulphur, nitrate of strontium, nitrate of potash, and gunpowder.

COMMUNICATIONS RECEIVED.

The Editor of the SCIENTIFIC AMERICAN acknowledges, with much pleasure, the receipt of original papers and contributions upon the following subjects: On Boiler Explosions. By B. F. C., and by J. M. L. On Public Buildings. By J. B. On Balloons. By J. F. B. On Migratory Spiders. By J. S. D. On Thomas Edward, Naturalist. By —. On the Suez Canal. By —. On the Ball Puzzle. By J. T. H. On Mathematics. By T. F.

Also inquiries and answers from the following: J. O.—J. L. L.—E. G. S.—W. T.—C. C.—S.—J. R.—H. H. D.—A. G. F.—H. F. A.—B. F. G.—T. W. S.—R. M.—E. H.

HINTS TO CORRESPONDENTS.

Correspondents whose inquiries fail to appear should repeat them. If not then published, they may conclude that, for good reasons, the Editor declines them. The address of the writer should always be given.

Inquiries relating to patents, or to the patentability of inventions, assignments, etc., will not be published here. All such questions, when initials only are given, are thrown into the waste basket, as it would fill half of our paper to print them all; but we generally take pleasure in answering briefly by mail, if the writer's address is given.

Hundreds of inquiries analogous to the following are sent: "Who makes water motors? Who sells pressure-regulating gas burners? Whose is the best water wheel? Who sells batteries for plating? What is the price of peroxide of manganese in the New York market?" All such personal inquiries are printed, as will be observed, in the column of "Business and Personal," which is specially set apart for that purpose, subject to the charge mentioned at the head of that column. Almost any desired information can in this way be expeditiously obtained.

OFFICIAL. INDEX OF INVENTIONS FOR WHICH Letters Patent of the United States were Granted in the week Ending December 12, 1876. AND EACH BEARING THAT DATE.

[Those marked (r) are reissued patents.]

A complete copy of any patent in the annexed list including both the specifications and drawings, will be furnished from this office for one dollar. In ordering, please state the number and date of the patent desired, and remit to Munn & Co., 37 Park Row, New York city.

[This list should have been published before the two in our last week's issue, but the copy did not arrive in time.]

Table listing various inventions and their patent holders, such as Air valve for blast cylinders, Bake pan hanging, Bale band stretcher, etc.

Bosom pad, J. C. Tallman 185,362
Bottle stopper fastener, C. H. Porter 7,424
Bottles, washing, Schmidt & Dixon 185,358
Box opener, Fisher & Ingersoll 185,223

Pressing metal into ingots, J. B. Tarr 185,197
Propelling vessels, etc., Crosby & Vivartas 183,301
Railroad frog, W. T. Egan 185,167
Railroad jack, C. W. Hornor 185,178

Feathers, renovating, I. L. Fisher 185,824
Feather renovator, H. G. O. Fabst 185,868
Feed water heater, A. Carpenter 185,838
Flask for casting, H. H. Fisher 185,904

9,690.—CARRIAGE TOP JOINT.—G. F. Smith, Plantsville, Conn.
9,691.—STOVES.—N. S. Vedder, Troy, N. Y., et al.
SCHEDULE OF PATENT FEES.
On each Caveat \$10
On each Trade mark 25

Advertisements.

Inside Page, each insertion --- 75 cents a line.
Back Page, each insertion --- \$1.00 a line.
Engravings may head advertisements at the same rate per line, by measurement, as the letter press.

WANTED.—SITUATION AS draughtsman or shop foreman. Advertiser is a practical machinist, liberally educated, and has been for three years draughtsman on waterworks construction.

REVERSIBLE HOISTING ENGINE FOR ALL PURPOSES. Cheap, simple, durable and effective. LIDGERWOOD M'FG CO. 165 Pearl St., N. Y.

FRICION CLUTCHES AND ELEVATORS. VOLNEY W. MASON & CO. PROV. R. I.

SPARE THE CROTON AND SAVE THE COST. Driven or Tube Wells furnished to large consumers of Croton and Riedgewood Water.

THE ACME PIPE CUTTER CUTS WROUGHT IRON, BRASS AND COPPER PIPES, BOILER TUBES, ROUND IRON, SHAFTING, ETC.

AMATEUR PHOTOGRAPHIC APPARATUS. Latest invention. Every person can operate with perfect success. Complete with chemicals, &c. Price, \$10.00; small size, \$5.

BOLT CUTTERS. Dies open and close and Bolt thrown out automatically. One pattern, holds finished bolts on centres and threads them with reater accuracy and uniformity.

PUNCHING DROPS Hammers and Dies, for working Metals, &c. THE STILES & PARKER PRESS CO., Middletown, Conn.

ON THE PROGRESS OF AERONAUTICS. An essay read before the Aeronautical Society of Great Britain. By Frederick W. Brearey, Secretary of the Association.

ALUMINIUM—ITS CHARACTER, Weight, Industrial Uses, Alloys, Method of Manufacture, and Cost in Market.

A FLY-WHEEL ACCIDENT.—With drawings, showing the faulty construction of the fly wheel, the reasons for the breakage; with practical directions for the avoidance of such occurrence.

STREET PAVEMENTS AND SIDEWALKS.—A description of the best kinds at present in use in various large cities of the U. S.

ON THE PREPARATION OF DEXTROSE.—Maltose (Malt Sugar), and its use in Brewing.—By Wm. Geo. Valentine, Ph.D., Professor of the Royal College of Chemistry.

ARSENIC IN THE ARTS.—A Lecture before the Medical Association of Central New York. By S. A. Lattimore, LL.D., Professor of Chemistry in the Rochester University.

DESIGNS PATENTED.

9,666.—BUSINESS CARDS.—J. M. Huiskamp, Keokuk, Iowa.
9,667, 9,668.—KNIT FABRICS.—M. Landneberger, Philadelphia, Pa.
9,669.—BILL HEADS, ETC.—D. L. Proudfit, Plainfield, N. J.

DESIGNS PATENTED.

9,686.—SALVER.—A. Conradt, Middletown, Conn.
9,687.—SATCHELS, ETC.—W. Heller, New York city.
9,688.—TYPES.—A. Little, New York city.
9,689.—PAPER BOX.—E. Morgan, Springfield, Mass.

Founded by Mathew Carey, 1785.

BAIRD'S SCIENTIFIC CATALOGUES
BOOK

Now Ready, New Revised Editions.
Of our valuable SCIENTIFIC BOOK CATALOGUES, which will be sent by mail gratis, and free of postage, on application.
We are now receiving and keeping in stock the most important ENGLISH AND AMERICAN SCIENTIFIC BOOKS as they are published, and are prepared to furnish them or to give information in regard to all American and Foreign publications in this department of literature.

HENRY CAREY BAIRD & CO.
Industrial Publishers, Booksellers & Importers,
810 Walnut Street, Philadelphia.

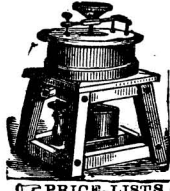

BRADFORD MILL CO.
Successors to Jas. Bradford & Co.
MANUFACTURERS OF
French Burr Millstones,
Portable Corn & Flour Mills,
Smut Machines, etc.
Also, dealers in Boring Cloths and
General Mill Furlishing.
Office & Factory, 168 W. 2d St.
CINCINNATI, O.
J. R. Stewart, Pres. W. R. Dunlap, Sec.
PRICE-LISTS SENT ON APPLICATION.



Small Tools of all kinds; also GEAR WHEELS, parts of MODELS, and materials of all kinds. Castings of Small Lathes, Engines, Slide Rests, &c. Catalogues free. GOODNOW & WIGHTMAN, 23 Cornhill, Boston, Mass.

STILWELL'S PATENT
Lime Extracting Heater and Filter.
Indispensable to economy in use of steam.
PRICES GREATLY REDUCED.

Catalogue on application to the manufacturers,
STILWELL & BIERCE MFG CO., Dayton, Ohio.

\$5 to \$20 per day at home. Samples worth \$5 free. STINSON & CO., Portland, Me.

Lathes, Planers, Shapers, Drills,
Gear & Bolt Cutters, &c. E. GOULD, Newark, N.J.

IMPORTANT FOR ALL CORPORATIONS AND MANUFACTURERS.—**Buerk's Watchman's Time Detector**, capable of accurately controlling the motion of a watchman or patrolman at the different stations of his beat. Send for circular.
J. E. BURK, P. O. Box 979, Boston, Mass.
N. B.—The suit against Imhaeuser & Co., of New York, was decided in my favor, June 10, 1874. Proceedings have been commenced against Imhaeuser & Co. for selling, contrary to the order of the Court. Persons using clocks infringing on my patent, will be dealt with according to law.

SEE PHOTOGRAPHIC APPARATUS & CHEMICALS compete, with directions, \$10. No toy; takes pictures 4x5 1/2 inches. Send for illustrated circular.
B. MORGAN, 14 Ann St. New York, P. O. Box 4349.

WANTED! SALESMEN at a salary of \$1200 a year to travel and sell goods to Dealers. NO PEDDLING. Hotel and traveling expenses paid. Address, MONITOR MANUFACTURING CO., Cincinnati, Ohio.

WROUGHT IRON BEAMS & GIRDERS

THE UNION IRON MILLS, Pittsburgh, Pa., Manufacturers of improved wrought iron Beams and Girders (patented).
The great fall which has taken place in the prices of iron, and especially in Beams used in the construction of FIRE PROOF BUILDINGS, induces us to call the special attention of Engineers, Architects, and Builders to the undoubted advantages of now erecting Fire Proof structures; and by reference to pages 52 & 54 of our Book of Sections—which will be sent on application to those contemplating the erection of fire proof buildings—THE COST CAN BE ACCURATELY CALCULATED, the cost of insurance avoided, and the serious losses and interruption to business caused by fire; these and like considerations fully justify any additional first cost. It is believed, that were owners fully aware of the small difference which now exists between the use of Wood and iron, that in many cases the latter would be adopted. We shall be pleased to furnish estimates for all the Beams complete, for any specific structure, so that the difference in cost may at once be ascertained. Address
CARNEGIE, BROS. & CO., Pittsburgh, Pa.

A NEW DEPARTURE, TRAVELING men wanted. STAMP GOODS, and good salaries. Salary \$75 a month. Hotel and traveling expenses paid. S. A. GRANT & CO., manufacturers of ENVELOPES and PAPER, 2, 4, 6, and 8 Home St., CINCINNATI, OHIO.

\$50.00 SCREW-CUTTING FOOT LATHES—Foot Drill Presses. Send for Circular to H. L. SHEPARD, Cincinnati, O.

BIG PAY to sell our RUBBER PRINTING STAMPS. Terms free. TAYLOR & Co., Cleveland, O.

Blake's Patent Stone & Ore Crusher.

NEW PATTERNS, with important improvements, and abundant strength. This is the only machine used by the principal MUNICIPAL RAILROAD and MINING CORPORATIONS and CONTRACTORS in the United States and foreign countries, for breaking hard and brittle substances to ANY SIZE. Send for circular.
ALL STONE CRUSHERS not made or licensed by us, containing vibratory convergent jaws, actuated by a revolving shaft and fly-wheel, are infringements on our patent, and makers and users of such will be held accountable. Address,
BLAKE CRUSHER CO., New Haven, Ct.

P. BLAISDELL & CO.,
Worcester, Mass.,

Manufacturers of the Blaisdell Patent Upright Drills and other first-class Machinists' Tools.

WOODWORTH SURFACE PLANERS, \$125. Planers and Matchers, \$350. S. C. HILLS, 78 Chambers Street, New York.

The HOADLEY PORTABLE STEAM ENGINE, WITH AUTOMATIC CUT-OFF REGULATOR AND BALANCED VALVE. THE BEST & MOST ECONOMICAL ENGINE MADE. SEND FOR CIRCULAR.
The J.C. HOADLEY CO. LAWRENCE, MASS.
STATE WHERE YOU SAW THIS.

PAPER BARRELS BY A NEW, CHEAP AND SUCCESSFUL PROCESS. See THE SOUTH, January 20th. Sample keg at THE SOUTH office, 22 Fulton Street, N. Y.

L. SMITH HOBART, JOHN C. MOSS, D. I. CARSON,
President. Superintendent. General Agent.



RELIEF PLATES IN HARD TYPE METAL,
For Printing

ALL KINDS OF PICTORIAL ILLUSTRATIONS
In Books, Newspapers, and Catalogues.

These plates are an excellent substitute for woodcuts, being used in precisely the same way, giving equally good results for much less money.

ELECTROTYPES AND STEREOTYPES are made from them in the usual manner. We offer special advantages to

MANUFACTURERS AND INVENTORS, as our mechanical work is of the best quality and rapidly executed.

Our plates are used satisfactorily in the SCIENTIFIC AMERICAN and the SCIENTIFIC AMERICAN SUPPLEMENT, and by Manufacturers and Publishers in all parts of the country.

"COPY."

We work direct only from Prints or properly prepared Pen and Ink Drawings. Any other copy may be furnished, such as Photographs, Pencil Sketches, or the articles themselves, in which cases we have drawings made in the best manner by our own trained draughtsmen. Photographs, taken in the ordinary way, are suitable, and they may be of any size. We make the plates larger or smaller, as desired.

We are glad to have customers prepare their own Pen Drawings, and append one or two

DIRECTIONS TO ARTISTS:

The most important requisite in Drawings for our use is that every line shall be perfectly black.

The paper or drawing board must be white and smooth. For fine work drawings should be made double the scale of the plate desired.

Carefully observing these main points, the artist has the utmost freedom in his choice of styles of drawing.

For further information and fine samples of our work, send stamp for current number of our illustrated Quarterly Circular.

WE ALSO PUBLISH,



LIST OF ENGRAVINGS.

1. THE LETTER WRITER.
2. THE CROSSING SWEEPER.
3. THE ROYAL PRINCESSES.
4. THE SKEIN WINDER.
5. THE SPANISH SISTERS.
6. A REST ON THE HILL.
7. THE FAIR CORRESPONDENT.
8. BARTHAM'S DIRGE.
9. GOING TO SCHOOL.
10. PEEP O'DAY BOY'S CABIN.
11. THE SCANTY MEAL.
12. THE AMAZON.

Printed on heavy toned plate paper, 12x15 inches.

Liberal discount to the trade. Sent postpaid on receipt of price.

Please say where you saw this.

PHOTO-ENGRAVING CO., 67 Park Place, New York.

STEAM PUMPS.

FIRST PRIZES, CENTENNIAL, PHILA., VIENNA, PARIS, NEW YORK, BALTIMORE, BOSTON. Send for circular of recent patented improvements. THE NORWALK IRON WORKS CO., South Norwalk, Conn.

IT PAYS to sell our Rubber Hand Printing Stamps. Terms free. G. A. HARPER & BRO., Cleveland, O.

\$80 A Month and Expenses, Salesmen wanted to sell to Dealers. Samples free. Send stamp. S. Foster & Co., Cincinnati, O.

MOSAIC SAWS 50c. a doz., Fine Scroll Saws 20c. a doz. Sent free by mail. J. M. SHELD, Williamsport, Pa.

BAKER'S Rotary Pressure Blower

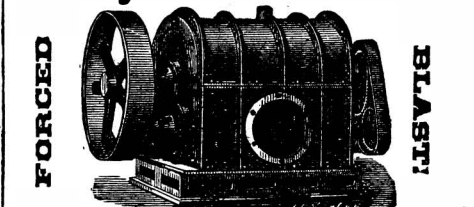

Warranted superior to any other.
WILBRAHAM BROS.
No. 2318 Frankford Avenue, Philadelphia:

\$290. FOR BEST PIANOS IN THE WORLD—in use all over the U. S. in over 900 towns by persons who will find in our Illustrated Circular, probably residents of your own place, or very near, where you can try our pianos. Genuine Rosewood—overstrung—full iron plate—7-1-3 octaves—Agraffe—and possessing every improvement known, and warranted 5 years by a responsible incorporated Manufacturing Co., referring by permission to the Chemical National Bank, New York City, by far the strongest bank in America. Pianos sent everywhere on trial. We have no agents. Send for Illustrated Circular giving full particulars. Address: UNITED STATES PIANO COMPANY, (Please name this paper.) 810 Broadway, New York.

WANTED THE SOLE MANUFACTURE, for England, of one or two Patent Articles in demand by steam users. Advertisers have good manufacturing premises, and a first-class connection among steam users in England and the Continent. Apply in first instance by letter to P. S. B., care of Mr. G. STREET, Advertising Offices, 30 Cornhill, London, E. C., England.

\$12 a day at home. Agents wanted. Outfit and terms free. TRUE & CO., Augusta, Maine.

SUBMARINE FOUNDATIONS.—Being a description, with dimensions and scale drawings of the apparatus employed at Pola Harbor, Austria. Price, 10 cents. SCIENTIFIC AMERICAN SUPPLEMENT No. 30. To be had at this office and of all newsdealers.



[ESTABLISHED 1846.]

Munn & Co's Patent Offices.

The Oldest Agency for eliciting Patents in the United States.

THIRTY YEARS' EXPERIENCE.

MORE PATENTS have been secured through this agency, at home and abroad, than through any other in the world.

They employ as their assistants a corps of the most experienced men as examiners, specification writers, and draughtsmen, that can be found, many of whom have been selected from the ranks of the Patent Office.

SIXTY THOUSAND inventors have availed themselves of Munn & Co.'s services in examining their inventions and procuring their patents.

MUNN & CO., in connection with the publication of the SCIENTIFIC AMERICAN, continue to examine inventions, confer with inventors, prepare drawings, specifications, and assignments, attend to filing applications in the Patent Office, paying the Government fees, and watch each case, step by step, while pending before the examiner. This is done through their branch office, corner F and 7th Sts., Washington. They also prepare and file caveats, procure design patents, trade marks, and reissues, attend to rejected cases (prepared by the inventor or other attorneys), procure copyrights, attend to interferences, give written opinions on matters of infringement, furnish copies of patents, and, in fact, attend to every branch of patent business, both in this and in foreign countries.

A special notice is made in the SCIENTIFIC AMERICAN of all inventions patented through this agency, with the name and residence of the patentee. Patents are often sold, in part or whole, to persons attracted to the invention by such notice.

Patents obtained in Canada, England, France, Belgium, Germany, Russia, Prussia, Spain, Portugal, the British Colonies, and all other countries where patents are granted, at prices greatly reduced from former rates. Send for pamphlet pertaining specially to foreign patents, which states the cost, time granted, and the requirements for each country.

Copies of Patents. Persons desiring any patent issued from 1836 to November 26, 1867, can be supplied with official copies at reasonable cost, the price depending upon the extent of drawings and length of specifications.

Any patent issued since November 27, 1867, at which time the Patent Office commenced printing the drawings and specifications, may be had by remitting to this office \$1.

A copy of the claims of any patent issued since 1838 will be furnished for \$1.

When ordering copies, please to remit for the same as above, and state name of patentee, title of invention, and date of patent.

A pamphlet, containing full directions for obtaining United States patents, sent free. A handsomely bound Reference Book, gilt edges, contains 140 pages and many engravings and tables important to every patentee and mechanic, and is a useful handbook of reference for everybody. Price 25 cents, mailed free.

Address
MUNN & CO.,
Publishers SCIENTIFIC AMERICAN,
37 Park Row, N. Y.
BRANCH OFFICE—Corner of F and 7th Streets,
Washington, D. C.

Advertisements.

Inside Page, each insertion --- 75 cents a line. Back Page, each insertion --- \$1.00 a line.

DO YOUR OWN Printing. First Premium award of All at Centennial, Hand and Self-Inking. Save money! Do more advertising.

MACHINISTS' TOOLS. NEW AND IMPROVED PATTERNS. Send for new illustrated catalogue. Lathes, Planers, Drills, &c.

HARTFORD STEAM BOILER Inspection & Insurance COMPANY.

W. B. FRAVLE, V. Pres't. I. M. ALLEN, Pres't. I. B. PIERCE, Sec'y.

CIVIL ENGINEER and EXPERT. HENRY A. ST JOHN, 31 & 23 Broad St., Room 8, New York City.

ROCK DRILLING MACHINES AND AIR COMPRESSORS. MANUFACTURED BY BURLEIGH ROCK DRILL CO. FITCHBURG MASS.

Now Ready. ILLUSTRATED HISTORY OF THE CENTENNIAL EXHIBITION OF 1876.

The Full History and progress of the Exhibition, Maps of the Grounds, Engravings of the Buildings, and accounts of all the most notable Scientific and Mechanical objects.

In addition to this splendid History of the Centennial Exhibition, the SCIENTIFIC AMERICAN SUPPLEMENT for 1876 contains a vast amount of reading matter of great value for reference and preservation.

MUNN & CO., Publishers, 37 Park Row, New York.

N. B.—We supply the SCIENTIFIC AMERICAN and SUPPLEMENT for 1877 to subscribers at the combined rate of \$7 for the two papers, we paying postage.

MUNN & CO., PUBLISHERS.

Niagara Steam Pump Works. ESTABLISHED 1826. CHARLES B. HARDECK, No. 23 Adams Street, BROOKLYN, N. Y.

NON-COMBUSTIBLE STEAM BOILER AND PIPE COVERING WITH "AIR SPACE" IMPROVEMENT.

HOME Insurance Co. of New York. Office, No. 135 BROADWAY, N.Y. CASH CAPITAL, \$3,000,000 00

PERFECT NEWSPAPER FILE

The Koch Patent File, for preserving newspapers, magazines, and pamphlets, has been recently improved and price reduced.

MUNN & CO., Publishers SCIENTIFIC AMERICAN.

TAKE NOTICE. We have the largest and best selling Stationery Package in the World.

Working Models

And Experimental Machinery, Metal or Wood, made to order by J. F. WERNER, 62 Center St., N. Y.

\$66 a Week in your own town. Terms and \$5 outfit free. H. HALLETT & CO., Portland, Maine.

Dayton Cam Pump. THE ONLY PUMP IN THE MARKET DESIGNED AND CONSTRUCTED ESPECIALLY FOR BOILER FEEDING.

Smith, Vaile & Co., DAYTON, OHIO.

WANTED—Men to solicit orders for our goods. Permanent Employment, good salary.

VINEGAR. How made in 10 hours from Cider, Wine or Sorghum without using drugs.

AGENTS. 64 page Illustrated Catalogue, Free. Boston Novelty Co., Boston, Mass.

OTIS' SAFETY HOISTING Machinery. OTIS, BROS. & CO., No. 348 Broadway, New York.

ENGINES, BOILERS, MACHINERY. Thoroughly overhauled and equal to new.

WE ENAMEL in FINE JET BLACK every variety of turned wood work parts of machinery, castings, tinware and other metal work.

\$984 Made by one Agent in 57 days. 13 new articles. Samples free. Address, C. M. LININGTON, Chicago.

Second-Hand Machinery for Sale.

The Machinery and Tools of the Utica Steam Engine Co., comprising a large assortment of Machinery and Tools for Machine Shops, Boiler Shop, Forge Shop, Foundry, &c.

Steel Castings,

From 1-4 to 10,000 lbs. weight. An invaluable substitute for expensive forgings, or for malleable iron castings requiring great strength.

Wood-Working Machinery, Such as Woodworth Planing, Tongueing, and Grooving Machines, Daniel's Planers, Richardson's Patent Improved Tecon Machines, Mortising, Moulding, and Re-Saw Machines, and Wood-Working Machinery generally.

WITHERBY, RUGG & RICHARDSON, 26 Salisbury Street, Worcester, Mass. (Shop formerly occupied by R. BALL & CO.)

DICKINSON'S ADJUSTABLE DIAMOND TOOL. And Shaped Diamond Carbon Points, indispensable for Truing Emery Wheels, Grindstones, Hardened Steel and Paper Calender Rollers, Drilling, Planing, Moulding and Sawing Stone.

THE BEST AND MOST ECONOMICAL Boiler Feeder

FRIEDMANN'S INJECTOR, MANUFACTURED BY NATHAN & DREYFUS, New York. 108 Liberty St.

Send for Circular.

GEORGE C. HICKS & CO., Baltimore, Md. CLAY REPORTS, TILES, FIRE BRICKS, &c.

Cheapest Rotary Hand Cornsheller in the U. S. Guaranteed to be the simplest, cheapest, most durable, effective and the best.

MACHINERY OF EVERY DESCRIPTION, COLD ROLLED SHAFTING, HANGERS, PULLEYS, COUPLINGS, BELTING, TANITE EMERY WHEELS AND GRINDERS, IN STOCK.

FOR ALL KINDS OF MACHINERY—Apply to S. C. HILLS, 78 Chambers St., New York.

\$55 & \$77 a Week to Agents. Samples FREE. P. O. VICKERY, Augusta, Maine.

\$10 to \$500 INVESTED IN WALL ST. Often leads to wealth. A 72 page book explaining everything, and a copy of the Wall Street Review, sent free.

JOHN HICKLING & CO., Bankers and Brokers, 72 Broadway, New York

MESSRS. B. DAMBACHER & CO., Hamburg, Germany, dealers in American Wood-Working Machinery and Tools of all kinds.

SHAFTS, PULLEYS, HANGERS, COUPLINGS ETC.

In Stock, and for Sale by WILLIAM SELLERS & CO., Philadelphia, and 79 Liberty St., New York.

Planing and Matching.

Moulding, Re-sawing, and Tenoning Machines. Scroll Saws and General Wood-working Machinery.

\$57.60 AGENT'S PROFITS per week. Will prove it or forfeit \$500. New articles are just patented. Samples sent free to all. Address, W. H. CHIDESTER 213 Fulton St., New York.

WANTED Salesmen to sell light hardware to Dealers, No PEDDLING. Salary, \$1,200 a year. Hotel and traveling expenses paid. Address DEFIANCE M'FG CO., Chicago, Ill.

EAGLE FOOT LATHES, With Scroll and Circular Saw Attachments, Slide Rest, Tools, &c.; also Small Engine Lathes, Metal Hand Planers, &c.

MACHINERY OF IMPROVED STYLES FOR making SHINGLES, HEADING and STAVES; also GAUGE LATHES for TURNING HANDLES.

Pond's Tools.

Engine Lathes, Planers, Drills, &c. Send for Catalogue. DAVID W. POND, Successor to LUCIUS W. POND, Worcester, Mass.

\$39 Each week to Agents, Goods Stable, 10,000 fractional shares received. Terms liberal. Particulars free. J. Worth & Co. St. Louis, Mo.

\$3 WATCHES. Cheapest in the known world. Sample watch and outfit free to Agents. For terms address COULTER & CO. Chicago

ESTABLISHED 1844. JOSEPH C. TODD, (Formerly of Todd & Rafferty), ENGINEER and MACHINIST.

J. C. TODD, 10 Barclay St., New York, or Paterson, N. J.

PATENT COLD ROLLED SHAFTING.

The fact that this shafting has 75 per cent. greater strength, a finer finish, and is truer to gauge, than any other in use, renders it undoubtedly the most economical.

AGIFT By an arrangement with the Publisher we will send every reader of this Paper a sample package of Transfer Pictures free.

The Toll-Gate! Prize Picture sent free! An ingenious gem! 50 objects to find! Address, with stamp, E. C. ABBEY, Buffalo, N. Y.

THE TANITE CO., STROUDSBURG, PA. EMERY WHEELS AND GRINDERS. GEO. PLACE, 121 Chambers St., New York Agent.

BOLT CUTTERS Schlenker's New Machine Revolving-Die. Send for Catalogue, giving price and full description.

NOYE'S MILL FURNISHING WORKS are the largest in the United States. They make Burr Millstones, Portable Mills, Smut Machines, Packers, Mill Picks, Water Wheels, Pulleys and Gearing, specially adapted to flour mills.

Boults Patent Reverse Motion Paneling, Variety Moulding and Dovetailing Machine. cuts Panels of any design or style of moulding in the solid wood with neatness and dispatch.

Simple, Durable and Efficient. Send for Pamphlet and Sample of work. Improved Solid Steel Cutters for all kinds of Variety Moulders made to order, and warranted by the B. C. MACHINERY CO. BATTLE CREEK, MICH.

FOR INVENTORS:—ALL KINDS OF Blanks (Deeds, etc.) A sample free. We make wood-cuts of Machines, etc. Furnish lists of names of manufacturers, Census of the U. S., Maps, etc.

Prospectus

OF THE SCIENTIFIC AMERICAN

For 1877,

THE MOST POPULAR SCIENTIFIC PAPER IN THE WORLD.

THIRTY-SECOND YEAR.

VOLUME XXXVI.—NEW SERIES.

The publishers of the SCIENTIFIC AMERICAN beg to announce that on the sixth day of January, 1877, a new volume was commenced. It will continue to be the aim of the publishers to render the contents of the new volume more attractive and useful than any of its predecessors.

To the Mechanic and Manufacturer. No person engaged in any of the mechanical pursuits should think of doing without the SCIENTIFIC AMERICAN.

Every number contains from six to ten engravings of new machines and inventions which cannot be found in any other publication.

TERMS OF SUBSCRIPTION.

One copy of the SCIENTIFIC AMERICAN will be sent for one year, 52 numbers, POSTAGE PREPAID, to any subscriber in the United States or Canada, on receipt of three dollars and twenty cents by the publishers.

One extra copy of the SCIENTIFIC AMERICAN will be supplied gratis for every club of five subscribers at \$3.20 each; or six copies for \$16.50 without extra copy. Postage free.

The Scientific American Supplement.

A weekly paper, uniform in size with the SCIENTIFIC AMERICAN, but a distinct publication. It contains working drawings of engineering works, and elaborate treatises on every branch of Science and Mechanics, by eminent writers, at home and abroad.

One copy of the SCIENTIFIC AMERICAN and one copy of the SCIENTIFIC AMERICAN SUPPLEMENT will be sent for one year, postage prepaid, to any subscriber in the United States or Canada, on receipt of seven Dollars by the publishers.

The safest way to remit is by Postal-Order, Draft, or Express. Money carefully placed inside of envelopes, securely sealed, and carefully addressed, seldom goes astray; but it is at the sender's risk. Address all letters and make all orders, drafts, etc., payable to

MUNN & CO., 37 PARK ROW, NEW YORK.

THE "Scientific American" is printed with CHAS. T. JENUE JOHNSON & CO.'S INK. Tenth and Lombard Sts., Philadelphia, and 59 Gold St., New York.