

# SCIENTIFIC AMERICAN

A WEEKLY JOURNAL OF PRACTICAL INFORMATION, ART, SCIENCE, MECHANICS, CHEMISTRY, AND MANUFACTURES.

Vol. XXIX.—No. 24.  
[NEW SERIES.]

NEW YORK, DECEMBER 13, 1873.

[\$3 per Annum  
IN ADVANCE.]

## ASCHENBRENNER'S IMPROVED SUGAR-MAKING PROCESS.

There is no process of chemical industry in which the waste reaches greater proportions than in that of sugar manufacture. Dr. Scoffern estimates the loss as nearer two thirds than one half, while another authority emphatically characterizes the proportion as enormous. The weight of the contents of a hogshead of sugar—according to an article on this subject recently published in *Iron*—is about 2,128 lbs. To obtain this quantity of sugar, 3,500 gallons of cane juice are often used, of a strength say of 9° Baumé. Each gallon at this average density contains 1.81 lbs. of sugar; hence 2,500 gallons contain 4,525 lbs. But the planter, as above noted, gets but 2,128 lbs.; hence the amount lost, or 2,397 lbs., is actually more than the maker has to sell. Of this loss 426 lbs. is molasses drained off, while the balance is waste of saccharine matter lost by caramelization; while ordinary processes have the still further defect of evolving, by the boiling of the cane juice, gases which impair the quality of the sugar.

With a view of overcoming these obstacles, the invention we herewith illustrate has been devised. According to the claims of its originator, the largest possible quantity of dry, pure, and naturally white sugar in marketable shape is produced. The importance of such an apparatus, if thoroughly efficient, cannot be overestimated, not only as influencing a vast industry, but as directly affecting every consumer of the staple; and hence no further introduction will be needed to bespeak for the following description the careful consideration which its subject deserves.

The course of the juice, as it emerges from the grinding mill, is through the trough, A, in which, at B, are arranged two inclined filters of different degrees of fineness, the liquid of course passing through the coarse one first. These filters are placed in two sets of grooves so that one pair can be removed for cleaning, leaving a second couple continuing to act, so that the operation need not be interrupted. The object of these appliances is to stop the passage of mechanical impurities floating in the juice. The conduit, B, discharges into a flannel, bucket-shaped receptacle, C, which it also so arranged over a tank, D, as to be

readily removed for cleaning and another quickly substituted, which serves to finish the initial filtering process.

The liquid is next conducted to three open kettles in succession. Each kettle has a double bottom so as to be heated by steam. In these receptacles, the juice is precipitated by means of lime and magnesia, a process facilitated by the high temperature imparted by the steam, after which the sediment is drawn off by suitable tubes at the bottom. Thus purified, the liquid passes away through the siphons, E, to another filter, F, which removes the last vestige of foreign substance which may still remain held in suspension. This apparatus consists of a metal case, in which is placed a second case, having two perforated ends and two perforated partitions, forming three compartments. The first is filled with sponge, and the second with bone black, and the third with charcoal. At each end is an empty space for the entering and emerging juice. The inner case is provided with handles to admit of its being lifted out of place for cleaning.

The pump, G, then lifts the juice into the sulphur box, H. This latter portion of the apparatus is of wood, encloses a paddle wheel which is actuated by the steam engine of the mill, and is fed with sulphurous fumes from the adjoining sulphur furnace, I. The revolving paddles throw the fluid into rapid agitation, so that it is thus more thoroughly exposed to the action of the gas and caused, it is claimed, to leave the box in a perfectly bleached condition. The emerging stream, which is of about two thirds of an inch in diameter, passes at once upon a long trough of sheet metal, J, which, heated interiorly and underneath by steam supplied through the pipes shown, serves to raise the temperature of the liquid to a degree not exceeding 194° Fah., by a condensation of 32° or 33° Baumé. Beneath this trough, at K, is arranged suitable apparatus for altering its degree of inclination at pleasure, thus hastening or retarding the flow.

Passing next through a connecting canal, the juice, in a stream half an inch in diameter, exits upon a second trough or box, L. This conduit is arranged similarly to the trough, J, and the liquid is here heated up from 212° to 220° Fah., and thereby condensed to 40° or 45° Baumé. When it reaches the lower end of the incline, occupying from 10 to 12 minutes in the transit, the stream has a thick-

ness of one third of an inch. At this point, in order to carry off all the vapor, hasten condensation, and prevent the boiling of the juice, a steam fan, M, is produced. By the effect of this appliance, together with that of the processes to which it has already been subjected, the liquid becomes so thick as to necessitate the use of a scraping apparatus, N, which consists of an endless band, passing over pulleys and provided with transverse blades, placed at suitable distances apart. This is set in motion by the engine and serves to convey the material to another inclined plane similar to those already described, where it is acted upon by a second fan, O. Finally the sugar, now in a crystallized condition, is removed by hand into the last receiver.

When it is desired to produce molasses, a small percentage may be obtained by making the incline of the troughs steeper, thus hastening the process and preventing the perfect drying of the sugar by the action of the two ventilators. The molasses thus made is said to be of the best quality and of the finest color. The entire period of time occupied by the juice in passing through the apparatus is stated to be in the neighborhood of forty-five minutes.

As regards economy, we are assured that the percentage of fuel saved is remarkably large—a fact which may be justly inferred from the advantageous and ingenious arrangement of heating surfaces, etc.

The patent for this invention, the credit of which is due to Dr. H. M. Aschenbrenner, is now pending, in the United States, through the Scientific American Patent Agency. For further information, address Mr. T. Masac, care R. Matthies & Co., 525 Apartado, Havana, Cuba.

## Depression in Railway Bonds.

Fifty-five railroad companies in the United States are now reported as in default for non-payment of interest on their bonds. The total amount of these bonds is \$217,959,311, or about thirteen per cent of the whole amount of the railroad bonds now outstanding.

With but few exceptions, the cause of the delinquency is due to the tightness of the money market and not to any inherent defect in the roads or their management, and the difficulty, therefore, will be only temporary.

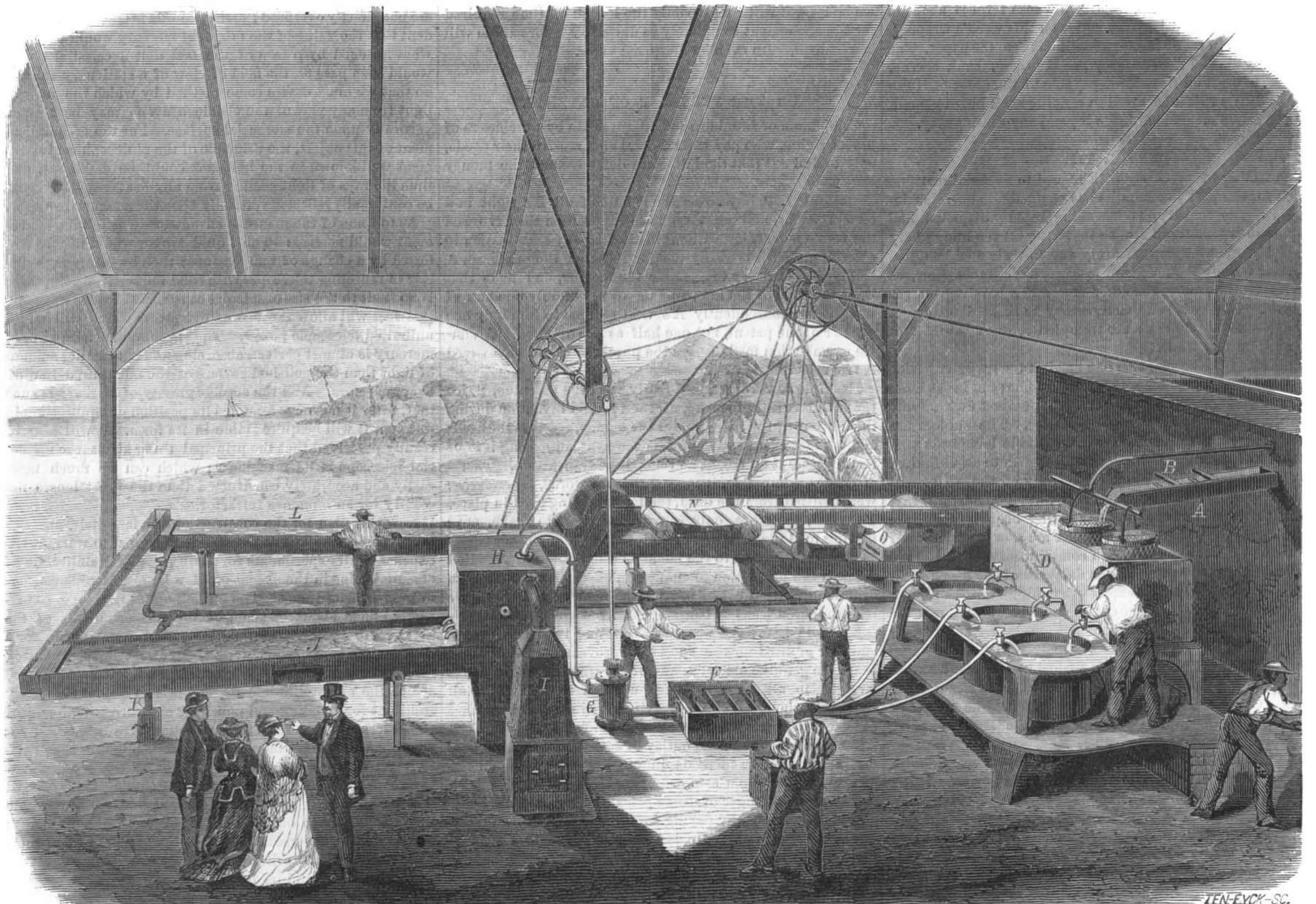

ASCHENBRENNER'S IMPROVED SUGAR-MAKING PROCESS.

# Scientific American.

MUNN & CO., Editors and Proprietors.

PUBLISHED WEEKLY AT  
NO. 37 PARK ROW, NEW YORK.

O. D. MUNN.

A. E. BEACH.

## TERMS.

One copy, one year.....	\$3 00
One copy, six months.....	1 50
CLUB RATES { Ten copies, one year, each \$2 50.....	25 00
{ Over ten copies, same rate, each.....	2 50

VOL. XXIX., No. 24. [NEW SERIES.] *Twenty-eighth Year.*

NEW YORK, SATURDAY, DECEMBER 13, 1873.

## Contents :

(Illustrated articles are marked with an asterisk.)

American railway traveling, an Englishman on.....	377	Patents, recent American and foreign.....	378
Answers to correspondents.....	379	Photography with gelatin, dry.....	373
Aquarium, the Brighton.....	375	Pipe coupling, improved.....	374
Better times.....	368	Protection of plants by artificial clouds, the.....	369
Business and personal.....	379	Railway bonds, depression in.....	367
Cattle cars, reward for improved.....	373	Railway, prismoidal.....	370
Chinese physiology.....	375	Rheumatism.....	373
Cocuyo, the.....	375	Savings of science, the.....	373
Crawshaw, Mr. Robert.....	370	Scientific and practical information.....	369
Electricity as yellow fever.....	372	Scientific experiments, prizes for.....	375
Eloquence and patent fuel.....	369	Sexadigitism.....	376
Files, to clean.....	376	Slag as a building material.....	371
Filtering and rectifying spirits.....	374	Snake poison.....	374
Flux and its preparation.....	371	Snow and earth shovel and plow, combined.....	374
German theory and its relation to hygiene, the.....	376	Sugar-making process, improved.....	367
Hippo-otusmus, the baby.....	370	Suppressed member, the.....	369
Hoo-sac tunnel, completion of the.....	372	Telescope of unlimited power, concerning.....	368
Horse bit, the.....	377	Tin plate is made, how.....	377
Ink in the teapot.....	375	Tongueless speech.....	373
Instead, an inexhaustible.....	376	Trees as historians of the past.....	372
Magic, the tricks of.....	373	Ventilation of the Senate chamber, the.....	372
Naime, the persistence of.....	375	Water as fuel.....	376
Nickel, the uses of.....	372	Wood choppers, California.....	376
Pain, the <i>oreo-idea regia</i> .....	371	Word to our subscribers, a.....	368
Patent decisions, recent.....	378	Zincing iron.....	376
Patents, a practical system for the sale of.....	377		
Patents, official list of.....	380		
Patents, on the purchase of.....	338		
Patents, property in.....	371		

## A WORD TO OUR SUBSCRIBERS.

Many of our subscribers will observe, printed in red ink on the wrapper covering this week's copy of the SCIENTIFIC AMERICAN, the announcement that in three weeks their subscription will be exhausted. The year and the volume thus expire, and we give notice a little in advance, and solicit a prompt renewal of all subscriptions, in order that our readers may experience no stoppage in the receipt of the journal, and that we may not miscalculate the quantity of paper to print at the commencement of a new volume.

The plan of discontinuing the paper when the time expires for which it is prepaid, we think preferable to the course adopted by many publishers, of continuing their paper indefinitely and collecting afterwards. The latter course is too much like having a bill presented for a suit of clothes after it is worn out. We shall be gratified to have every old subscriber renew, and doubly grateful if each will send one or more new names with his own.

We hope those of our subscribers whose term is about to expire, as admonished by the notice on this week's wrapper, will not delay in remitting for a continuance of the paper. The safest way to send money is by postal orders, bank checks, express, or draft on New York, payable to the order of Munn & Co. Little risk is incurred in sending bank bills by mail, but the above methods are safe beyond any contingency.

## BETTER TIMES.

The feeling of insecurity with regard to financial matters, which for the past two months has clogged the business interests of the country, is becoming rapidly dispelled, and people are beginning to realize that after all the hue and cry the panic is but a specter, mainly due to their own imagination. It was, in fact, a gigantic scare, a veritable panic, as baseless as the frantic rush of a crowd in a building on the shout of "fire," while its victims may be likened to such of the hapless bystanders as are trampled beneath the feet of the surging multitude.

Like all great storms, this one has left its ravages, which will doubtless be felt for some time to come; but in the main the horizon is clear and there is every prospect of a speedy return of business to its former channels. The subject has been freely discussed, theories innumerable have been ventilated, and dismal forebodings indulged in to an unlimited extent, until, as a sensation, the novelty of the excitement has died out. The talkers, therefore, having had their say, the workers, cool-headed and far-seeing business men, are striving to act; and while the former are now devoting their oratorical talents to the Spanish complications, the latter are busily endeavoring to repair the damages of the disaster.

Marked signs of improvement are exhibited in the reports from various quarters of the country, and notably so from the New England States. Total suspension, says an authority, is, in the majority of cases, being modified to half or three quarters time, and hands thus furnished employment are receiving wages enough to keep them well away from their doors. Collections are generally easier, and the record of protests of commercial paper and of suits in involuntary bankruptcy is largely diminished.

The mines of Pennsylvania have been kept open, although working hours have been reduced. The men have cheerfully accepted the situation, believing that small wages were better than absolute idleness. The iron masters, it is said, will shortly resume operations, although many have suffered very severely, notably for the cessation of orders for railroad supplies. Their renewal will necessarily assist the coal trade. Among the manufacturers there seems to be a general impression that the trouble is past, and we note that resurrections of

business are extensively in progress, although in many cases it has been found necessary to continue reductions of time and wages. The tobacco interest has suffered but little. The jewelry manufacturers had experienced a stagnation in their trade, but this is reported to be gradually passing away. The knitting-mills of the northern part of this State are rapidly receiving orders, and improvements in buildings and machinery are progressing as usual. It is expected that the great establishments in Cohoes, N. Y., will start on full time again as soon as the water is let on in the canals. The safe dealers have reduced prices and sales are said to be brisk. The dry goods trade is recovering, and a good holiday business is anticipated.

The war contingency, while serving to divert the popular mind from the financial stress, is becoming the means of supplying work for large numbers of men. We note the following important contracts, which indicate brisk business for several of the largest machine shops in the country: John Roach is to build engines and machinery for one new sloop of war, to cost \$630,000; for two similar vessels, at \$80,000; to repair four monitors, at \$720,000; and to build two engines for \$366,000. Quintard & Murphy are to construct engines for two sloops of war; the Delamater Iron Works, to repair the "Dictator;" Atlantic Works, of Boston, to repair two vessels; Hartford Iron Works, engines for sloops of war; Wright & Co., of Newburgh, similar work; Cramp & Sons, of Philadelphia, are to overhaul four monitors; the Harlan & Hollingsworth Company are to repair three ships of the same type, and it is stated that the Navy Department has more contracts yet to issue.

The effects of the disaster had been severely felt in the eastern States before the magnitude of the panic had become fairly comprehended in the West. In spite of this fact, however, the work of recuperation seems to be as rapidly advancing in that section of the country. The iron interest of Cleveland was embarrassed for a time; but as a rule, we learn that there has been scarcely any reduction either of force, wages, or time in the factories and shops of the city. In Cincinnati, of the 12,000 workmen there employed, it is stated that hardly five per cent of the total have lost their places; while from Dayton and Columbus comes a similar report. Local journals go so far as to state that this is even an improvement on the usual condition of affairs at this time of year. From Chicago, St. Louis, and Louisville, advices are generally encouraging; and the same is true of recent reports from Baltimore.

We regret to notice reductions of wages on some of the railroads, notably on the Delaware, Lackawanna and Western. We hardly think that the best interests of these great and wealthy corporations are served by such a course, and consider that it would be wiser to exhaust every other means of retrenchment prior to diminishing the incomes of those whose labor they employ.

Altogether the feeling manifested throughout the country is encouraging, and the general condition of business is uniformly quoted as sound. There is an abundant demand for our products, enough to maintain all our industries; so that, we believe, it will involve only the length of time required for the excitement completely to die away before trade will be resumed, with even an increased vigor.

## ON THE PURCHASE OF PATENTS.

Complaints of fraud are sometimes made by purchasers of patent rights, who pay their dollars and receive their deeds, only to find out that the latter are defective and the money lost.

Example 1. A buys from B one half of all B's right in a certain patent, and takes it on the supposition that B owns the whole patent, but without instituting any examination to ascertain if such is really the fact. After the purchase, A employs an attorney to examine the records, and finds that B, at the time of the sale, was the owner of only one half of the patent; consequently A's title secures to him only one quarter of the patent, not one half as he supposed. A simple examination made before the purchase would have saved A from the loss.

Example 2. A contracts verbally with the patentee, B, for the exclusive right to make, use, and sell an invention during the lifetime of the patent, pays the money, receives the deed; and without examination of the document, supposing it to be right, places it on record and closes the transaction. Thereafter, on examination, it appears that the words, *the exclusive*, were omitted from the deed, the letter *a* being used in place. The deed, therefore, only conveyed a right to make, etc.; leaving to B the privilege of granting as many other rights as he might choose to the business competitors of A. Had A taken the precaution to employ an experienced attorney to examine the deed before paying the money, he might have really secured what he bargained for.

Example 3. A buys a patent, supposing it to be the only one ever granted for the special improvement claimed. It bears the genuine official marks of government origin, looks straight in all its forms, and appears to him to be all right. Without making a search, he pays the money, takes the deed, and proceeds at once to manufacture the article. After much labor and the outlay of several thousand dollars for mechanism, he succeeds in putting the goods on the market, when, to his astonishment, he is served with legal papers as an infringer of some prior patent; and only gets clear of the trouble by paying damages and buying an interest in the first patent. He is thus compelled to pay twice for the same article, which he might have avoided had he employed the services of proper persons to examine as to title and infringements prior to the first payment.

Example 4. A contracts for a patent, supposing that the

device is a new thing. Surely, he thinks, the government of the United States would not issue a patent for an old device. He therefore concludes that it must be all right, pays the money, and receives a deed. Infringers make their appearance. He brings suit, and then, to his surprise, discovers that the invention is a very old one and the patent utterly worthless. The Patent Office is far from being reliable in its grants. The only safe way, where interests of value are at stake, is to have careful searches made by competent attorneys as to the validity of the patent.

The same remarks apply in respect to the scope of patent claims. The purchaser is too apt to suppose, in buying a patent, that the claim is broader than it is, and covers the manufacture of an article so as to exclude all competitors. He therefore goes extensively into the business, exhausting money and energy, only to find out, what an attorney's examination would have quickly revealed before hand, that the scope of the patent claim is very narrow, and the patent of little value.

## CONCERNING A TELESCOPE OF UNLIMITED POWER.

In volume I, number 3, of the *Mathematical Monthly*, for 1858, may be found an article written by Professor George R. Perkins, then of Utica, N. Y. It relates to a fluid parabolic mirror; and the problem is demonstrated that "if an open vertical cylinder, containing a fluid, be made to revolve with a uniform motion about its axis, the upper surface of the fluid will assume a perfect concave parabolic form." A table is appended which gives the focal distances corresponding to different velocities of rotation; and these have been deduced from actual mathematical calculation.

If mercury be used as the fluid, we shall obtain a concave parabolic mirror which will be theoretically perfect. We think it possible to make use of this kind of mirror for astronomical purposes; for all rays of light falling upon it parallel to its axis will be reflected to the focus of the parabola, where could be applied the ordinary magnifying apparatus, after the method employed in the Newtonian reflecting telescope.

Now it is necessary to reduce our theory to practice. The cylinder containing the mercury must revolve with a uniform motion; and it is our opinion that the mechanics of the present day are fully adequate to the construction of machinery which shall impart a uniform motion to a vessel of mercury many feet in diameter. This problem of uniform motion has been successfully solved: the astronomical instrument known as the chronograph is made to move almost perfectly uniformly; and the heavy clockwork which is employed in moving large refracting telescopes, in a direction contrary to the diurnal rotation of the earth, is often so perfect that a star, from its rising to its setting, can be kept almost exactly in the center of the field of view. Now certainly, since we have attained so perfect a uniformity of motion as this, machinery can be devised and constructed which shall impart the required uniform motion to an immense vessel of mercury. It is evident that gravity would not permit this mirror to be inclined for the purpose of viewing objects which are not directly overhead; and since this is true, it is also evident that the value of the mirror of mercury would be some what lessened by reason of the fact that a celestial object would soon pass off the field of view of a stationary mirror. So that we must devise some method by which the rays of light from any part of the visible heavens may be thrown vertically upon the mercurial surface. For the accomplishment of this object, the principle of the philosophical instrument well known as the heliostat could be employed, and thus the rays of light coming from any heavenly body could be continually reflected vertically upon the mercurial surface.

As to some of the manifest advantages which this instrument would possess: The liquid mirror would not be distorted by a change of temperature; thereby being far superior to reflecting telescopes with solid mirrors. Again, there is no limit to the size of mirrors constructed in this way; and this fact will allow the use of eye pieces which will afford unlimited telescopic power. The speculum surface, also, of mercury is almost perfect, absorbing a much smaller amount of light than the polished surface of the metal used in ordinary reflectors. And the specific gravity of mercury is such that, after it has once assumed its position of equilibrium in rotation, it will be quite stable in its form. It will also be readily perceived that the principal thing about the mercurial telescope is its machinery; which can be much more easily and accurately constructed than the great lenses necessary for an immense refractor.

Now this plan for the construction of a large telescope certainly possesses advantages sufficiently great to warrant the expense of all experiments for testing its practicability. The essential thing in the execution of a large telescope consists in the requisite funds. The million dollar telescope, so earnestly talked about by some of the correspondents of the SCIENTIFIC AMERICAN for several months past, calls for a considerable sum of money; the mercurial telescope, offering far greater power, calls for a far less sum of money. And again, the entire lifetime of an optician would be barely sufficient for grinding and polishing and correcting a pair of lenses large enough for a million dollar refracting telescope; whereas an immense mercurial telescope might be constructed inside of two years; indeed it might be easily completed before the Centennial of 1876, at Philadelphia, if it is desired that it be used on that occasion. Such an instrument would add indefinitely to our knowledge of physical astronomy; and, moreover, the great amount of light which a large mercurial mirror would collect, even from exceedingly faint celestial objects, would be particularly favorable for spectroscopic observation.

This method seems, at present, to be our last resort for



the construction of a large telescope. Definite action in regard to this matter should be taken immediately. Let some one take hold and do something; success is almost certain.

Amherst College, Mass. D.

REMARKS BY THE EDITOR.—The suggestion here made by our esteemed correspondent for the construction of a reflecting telescope of unlimited power is novel and ingenious. It is, moreover, theoretically correct. But when we come to consider the difficulties which beset astronomers in using their present large instruments, though these are small as compared with the gigantic machines intended by our correspondent, we confess his idea seems to us to be impracticable.

Whoever has attempted so simple a matter as the adjustment of the wires of a three inch transit instrument, by looking through it upon a small plane mercurial mirror, knows how considerable the difficulties are. Even the insensible pressure of the wind, upon the exterior of a solid stone building in which the adjustment was attempted, has been known to produce such vibrations of the surface of the mercury, although it was insulated by elastic supports, as to render the work of adjustment impossible; and success is only attained during an almost perfect calm. If these difficulties attend the use of a mercurial mirror of only a few inches in diameter, are we not justified in believing it to be impossible, in the present state of human mechanical skill, so to arrange a plane mercurial mirror of several feet in diameter that it shall remain free from vibration? But granting that it could be done, can we conceive of any method by which the rotation, necessary to produce the requisite concavity of the mirror, could be imparted and maintained without inducing vibration? We will grant that the motion could be sufficiently regulated, though an absolutely accurate clock has never yet been made.

But we will suppose the mirror to be complete, and the objections mentioned successfully overcome. The instrument necessarily occupies a horizontal position; it is, we will say, twenty feet in diameter, and we now wish to use it to the best advantage. For this purpose, two plane mirrors, equal in size to our mercurial mirror, will be necessary; and whether they are made of glass or metal, the difficulties connected with the final polishing of their surfaces into a condition of proper accuracy are seemingly as great as the maintenance without vibration of the rotating mercurial mirror.

We are of opinion that it would be considerably less difficult to construct a concave mirror of speculum metal or other solid material, of the dimensions stated, than to produce either of the other mirrors; while the speculum concave, by its capabilities for change of position, would render the use of the two plane mirrors unnecessary.

We should be glad if our correspondent, and other writers who desire, would point out the particular methods that may occur to them, by which the objections we have suggested might probably be overcome. The subject is one of much interest, and its further discussion may lead to profitable developments.

#### THE PROTECTION OF PLANTS BY ARTIFICIAL CLOUDS.

The practice among gardeners of protecting vegetables from the effects of frost, by lighting fires at such points that the wind will carry the heated air and smoke over the plants, is not new, and in some countries is one of the commonest agricultural operations. In Chili, where large vineyards exist upon the slopes of the Cordilleras, the plan has been found of the greatest value in saving the vines from the cold wind which sweeps down from the mountains; and it is stated that even the tenderest shoots are defended from the frost, at temperatures as low as 21° Fah.

The most recent experiments in this direction, and perhaps also the most extensive of late date, have been carried on by M. Fiabre de Rieunègre, one of the largest vine growers in France. It may be remembered that about a year ago we briefly adverted to this subject, and said that it had elicited commendation from a congress of vintners in the above mentioned country. Since then, however, M. de Rieunègre's experiments have been made, and with such remarkably good results that the matter is invested with a new and, at this season of the year, timely importance to all engaged in the cultivation of the vine in our Northern States. The investigator in the record of his researches considers that fires of tar or heavy oils are not suitable, notably from the fact that cheaper and more efficacious material can be obtained, and also that, in order to keep the former burning over a considerable period of time, an amount of attention is required which eventually becomes very onerous. Wheat chaff, he says, answers the purpose better than any substance he has used, as it burns slowly, produces large quantities of smoke, and costs but very little. Moss, saw dust, or worthless hay may be employed when chaff is not conveniently obtained. The material is piled in heaps of about eight feet diameter and forty feet apart. Three fires thus disposed are sufficient to protect two and a half acres of vines.

In describing his mode of experimenting, M. de Rieunègre says that, having selected a night when the thermometer appeared to be rapidly falling, he collected all his laborers, together with a large concourse of neighbors from the surrounding country. As soon as the mercury fell to 32° Fah., a signal was given and the match was applied to three hundred heaps of chaff and straw. The flames were carefully kept under; and in a very few minutes, a dense cloud of smoke had settled over a plain of 360 acres. The fires were continued until the thermometer had risen above the freezing point of water, but were renewed within twenty-four hours, when one of the coldest nights of winter set in, with a

strong breeze blowing from the northeast. New heaps were kindled in the direction of the wind, the great cloud was agitated; and although, it is stated, the vineyards of the surrounding country presented after the frost a scene of desolation, those protected by the smoke were unharmed. Thirty thousand dollars worth of plants were saved by the operation, at the sole expense of a quantity of worthless chaff and straw.

#### ELOQUENCE AND PATENT FUEL.

When we have subjects to write about which call for beautiful displays of rhetoric (and it may be remarked that the editorials of a scientific journal are not popularly supposed to sparkle with such brilliant coruscations of literary genius), we think, by sufficient study, we might prove equal to any ordinary requirement; but we doubt if, under the inspiration of so prolific and poetic a theme as "patent fuel," we could evolve from our inner consciousness anything approaching the following, with which a writer in *Les Mondes* introduces that topic. The quotation is remarkable in that it broaches an entirely new theory of the origin of fire, the peculiar ingenuity of which will doubtless commend itself to all scientific minds:

"The world was born yesterday. One day an unknown meteor rushed with the wind (!) upon the summit of a forest. The horizon reddened, trees burst in flames, the leaves driven by a breath of summer whirled in torrents through the atmosphere: birds driven from their nests uttered cries of distress, panthers fled howling away, reptiles writhed upon the cinders, and crocodiles plunged into the lagunes. Alone, immovable and erect, man regarded with mute astonishment the bloody shadow of the new guest. Suddenly he felt a gentle heat penetrate his fibers, as the prescience of a novel destiny. Fire was found. Then braved he the frost, drove back the night, and caused the grain to leap from the bosom of the earth. Lighting the forge, he melted, molded, and mastered metal; and metal, vibrating under the orchestra of the forge, sounded the chant of the victory of humanity." And after two pages of this to descend to the advantages of a patent fuel!

#### THE SUPPRESSED MEMBER.

Of all tyrants, the most tyrannical is custom. As capricious as the King of Dahomey, she is as inexorable as Mrs. Grundy. There is no king or kaiser whose rule is so burdensome or so meekly endured, the secret of her power lying in the delusion of her subjects that they are wholly free. Her laws are the only laws that perpetuate themselves; and though originally mere freaks of barbaric fancy, or usages of some forgotten stage of social development, they have shaped the lives of so many generations that they have become part of the social framework, and are harder to shake off than Sinbad's old man of the sea. Our heaviest taxes are those we pay to custom, her tribute takers, with fernseed in their shoes, finding their way into the innermost recesses of our daily life and controlling our conduct where we least suspect it.

A thousand illustrations might be given; but just now our wish is to call attention simply to one: our habitual and unreasonable suppression of a member whose cultivation would immensely increase our executive power, and prevent our being utterly disabled by certain accidents which all are liable to. The oriental custom of restricting education to the male half of the race seems to occidental minds at once unprofitable and absurd. What then would we think of a custom which should effect the systematic repression, not of the girls merely, but of half the boys; requiring number one of every pair of boys to be trained to the utmost strength and skill, and condemning number two to awkwardness, inaction and weakness? Worse than that: allowing him to do nothing not directly and necessarily subservient to number one, yet requiring him always to take number one's place in case he should meet with an injury. Such unprofitable servitude to other customs than our own would certainly be accounted ridiculous in the extreme; but after all, is it so much worse than our careful repression of the sinister half of each boy's working members?

"Don't use that hand" and "Use your right hand" are injunctions that the child hears from the very first; and before he is old enough to understand the spoken words, the outstretched left hand is put back and the coveted toy given only to the right.

"Why?" he asks as soon as he is old enough to demand a reason for the slight put upon the unoffending member.

"Because," replies mamma, sagely, "it is awkward," or, "it isn't polite."

Why it should be awkward or impolite to use the left hand, mamma never thinks to enquire. That the exigencies of military discipline in some fighting age of forgotten barbarism made it necessary that all men should give preference to the same hand, or some other equally wise and potent reason established the custom at a time when one skillful hand was enough for one person, mamma neither knows nor cares; nor does it occur to her that times change, and that a good rule for one generation may be a bad one for another. Grant that social convenience is favored by the uniform use of the right hand for certain purposes, that is no sufficient reason for subordinating the left hand in all things, especially when the conditions of our lives and occupations make it very frequently imperative that the untrained left hand shall learn to do the work of the disabled right hand.

From the nursery the boy goes to school, and here the same unreasonable prejudice awaits him. Through instinct, accident, or caprice, he grasps his pen or pencil with his left hand, and his knuckles are sharply rapped for it. Why should he not be taught to write and draw with both hands?

It would take but little if any more time; and if it did, it would only keep him busy during moments which he would otherwise devote to idleness or mischief. The acquisition would never be worthless, and it might be of immense convenience to him. He might never have occasion to use his double capacity after the fashion of the popular scientist and teacher whose two-handed black board sketches are such a delight to his auditors, and who is said to pursue his microscopic studies with a pen at one side and a pencil at the other, drawing with one hand and writing with the other as the development of his subject may require; nevertheless his two-fold skill would ever be a possible source of satisfaction and advantage to him. He would be free at any moment to rest a hand exhausted by protracted use without any interruption of his work; he would be less likely to be disabled by trifling hurts; and in case one hand were stiffened by heavy labor, the other might be kept in readiness for delicate manipulations, for writing, drafting and the like.

We have seen more than one ambidextrous artisan whose ability to handle tools with either hand, as occasion demanded, gave him constant advantages over his one handed mates, not only in the avoidance of fatigue, but in the performance of nice work and the overcoming of difficulties, hard to come at by those restricted to the use of a single hand. The right handed man who can use a hammer or a knife readily with his left hand, or can tie or untie a knot when his right hand is otherwise engaged, will find frequent use for his skill. Indeed the advantages we miss through the non-cultivation of the neglected member are infinite in number and of incessant recurrence. They are among the taxes we pay to custom.

It would be useless to recommend the mature to undertake the culture of their left hands. They have been "left" unused and untrained too long; and the proper time for such work is in childhood and youth, when the muscles are tractable and time abundant. But need it be useless to urge parents to encourage such training on the part of their children, or, at least, not to discourage it?

#### SCIENTIFIC AND PRACTICAL INFORMATION.

##### EUROPEAN RAILROADS.

According to the most recent statistical data, the total length of all the railroads in Europe is 58,650 miles. The largest number of lines is in Great Britain, aggregating 15,351 miles; Germany is next with 10,739 miles, then France, 10,511, Austria, 4,492, Russia, 4,758, and Belgium, 1,892.

##### ADULTERATION OF TEA IN ENGLAND.

The *London Globe*, in an article on the above topic, says that the ill effects, often attributed to tea drinking, in the majority of cases are not due to the properties of the leaf itself. Adulteration has become so common that out of 183,000,000 pounds which passed through the British Custom House in 1872, during the month of July alone a Sanitary Commission found 10,000,000 pounds utterly unfit for human consumption. In a single chest a magnet brought out 43 per cent of the whole in bits of iron, colored green. This wholesale rascality is done by the Chinese before exportation.

##### RED AND WHITE MUSCLES.

M. Ranvier points out that the red and white muscles of a body,—very clearly seen by removing the skin of a rabbit—which exist mingled in the same region, are different both in structure and properties. On applying the electric current, the white portions contract almost instantly, and respond even to rapid and continuous shocks. The red portions, on the contrary, are much more sluggish; it requires a certain time for them, apparently, to feel the excitement, while, on quick interrupted discharges of electricity being administered, they simply assume permanent contraction. It is believed by the author that the latter are involuntary and of the nature of the muscles of the heart or other portions relating to the animal existence; the former, however, he thinks, are controlled by the will.

##### NEW DERIVATIVES FROM CAOUTCHOUC.

While recently investigating the properties of Gaboon caoutchouc, M. Aimé Girard has succeeded in isolating a white crystallizable substance which, on analysis, became resolved into methylic ether and grape sugar. In a second series of researches, the same author, with Borneo rubber, has found another material analogous in aspect to the first, and containing the same elements, but differing in that it contained grape sugar condensed, in other words, answering to the formula C<sup>12</sup> H<sup>12</sup> O<sup>12</sup> instead of C<sup>6</sup> H<sup>6</sup> O<sup>6</sup>, as in the former instance. Continuing his studies to Madagascar caoutchouc, still another substance appeared, of which the sugar gave a molecule containing C<sup>18</sup> H<sup>18</sup> O<sup>18</sup>, or doubly condensed.

The series thus determined also has regular relative differences in physical properties. Thus the first derivative melts at 414° Fah., the second at 418°, and the third at 455°, the temperature rising with the degree of condensation, thus conforming to established laws. As regards optical properties, the first component is inactive on polarized light, the second turns the plane of polarization 32° to the right, the third determines a rotation of 79° in the same direction. M. Girard has therefore discovered an intimately connected series, representing ethers of which the acids are isomeric forms of grape sugar.

Instead of an edition of sixty thousand of the "special" as promised to advertisers, we shall print of this number seventy-five thousand to commence with, and probably a second edition of twenty-five thousand before the first of next January.

#### THE IRON WORKS AT MERTHYR TYDVIL, SOUTH WALES.

Among the rival iron districts which now pour out their millions of tons annually all over the world, Merthyr Tydvil, was one of the earliest in the field, its product being celebrated long before the Staffordshire mines were opened. The principal works at and in the neighborhood of Merthyr are Cyfarthfa (Mr. Robert Crawshay, the subject of our portrait), Pen-y-darren (Messrs. Fothergill & Co.), and the Dowlais Iron Company's. The first of these has as many as 5,000 hands on its pay roll, and the last 16,000.

The name of Crawshay has been identified with the Cyfarthfa works for three generations. The first ironmaster in the family was (in the words of one of his grandchildren) the son of a most respectable farmer in Normanton, Yorkshire. At the age of fifteen, father and son differed. "My grandfather, an enterprising boy, rode his own pony to London, then an arduous task of some fifteen or twenty days' traveling. On getting there he found himself perfectly destitute of friends. He sold his pony for \$75. He hired himself for three years by paying the \$75, the price of the pony. His occupation was to clean a counting house, to put the desks in order, and to do anything else he was told. By industry, integrity, and perseverance he gained his master's favor, and was termed 'The Yorkshire Boy.' The trade in which he was engaged was a cast iron warehouse. By honesty and perseverance, he continued to grow in favor. His master retired in a few years and left my grandfather in possession of his cast iron business in London, which was carried on on the very site where he ended his days—in York Road. My grandfather left his business in London and went to Merthyr Tydvil. Who started with humbler prospects in life than my grandfather? No man in the works is so poor but that he can command \$75. Depend upon it that any man who is industrious, honest, and persevering, will be respected in any class of life he may move in."

There is a sort of ancestral and patriarchal feeling at Cyfarthfa which seldom exists elsewhere. There are many men who have grown gray in the employment of the Crawshays, who have never changed or would wish to change their place. They have begun as children, perhaps only fetching and carrying small articles, for a few shillings a week, and have gone on to earn, as firemen and puddlers, their three pounds. There is not the same intense pressure to produce here as in other districts. The owner, having inherited a few loose millions, can afford to take things considerably and calmly. If you take the manager of a company, with his \$25,000 a year salary, and wanting to make another \$25,000 a year by his commission and percentage, you have, of course, a very different set of circumstances; he is anxious to produce as fast as possible;

but the owner of Cyfarthfa is reported to have once truly said that he could afford to shut up his works for fifty years. Mr. Robert Crawshay is the owner of Cyfarthfa Castle; the unique character of the stern rough place, fit residence for an iron king, impresses you strongly. Some iron rails, a kind of tramway, come almost to the front door. The place might be a fortress, a mill, a lunatic asylum, unless you knew to the contrary. A somewhat steep ascent leads you to the gardens behind the house, with conservatories and ferneries. Some of the hothouses are very rich in their contents. The flowers might be the glory of any conservatory, but even in looking at the flowers you could not get rid of the idea of iron and coal.

Mr. Crawshay is also well known as an amateur photographer, and his liberal encouragement of the art, by giving valuable prizes for specimens of portraiture, has already been commented on in our columns. He has recently executed a portrait of Mr. Justice Grove, F.R.S., the eminent philosopher and jurist, which the *Photographic News* describes as "nearly faultless."

#### THE BABY HIPPOPOTAMUS' BIRTHDAY.

The interesting fact of the first annual celebration of the birthday of Miss Guy Fawkes is announced by *Land and Water*. The individual bearing this much execrated name is an infantile hippopotamus in the Zoological Gardens in London, who, just one year ago on the fifth of November, was ushered into existence—a circumstance duly noted in these columns at the time. Mr. Frank Buckland, the well known naturalist, called upon the young lady with the usual felicitations and wishes of "many happy returns of the day." He arrived at about breakfast time, and found the object of his visit deeply absorbed in partaking of a breakfast from nature's fount, under water. He describes the condition and behavior of the babe, as follows:

"The water in the bath was as clear as crystal, and I was able to observe everything that went on. The mother lay herself down on her side, turning over like a huge bacon pig asleep. The young one stood on all fours at the bottom of the tank, and took her food very much after the fashion of a calf. She stayed under water from half a minute to a minute and three quarters; she then came to the surface, took a deep inspiration, and sank again, as quietly as a frog. It was very interesting to see with what little splash or noise

when it is moist and wet, she and her mother are let out into the bath outside; when it is dry and frosty, they are kept in the house, as the frost would crack and parch their delicate skins. When in her morning bath, she is very playful and plunges about like a porpoise. The pair of hippos sleep on the straw all night, but they spend a great portion of the day in their bath in the house in a sort of semi-sleep. They float up to breathe apparently without an effort, like corks rising to the surface. When under water, they keep their eyes wide open after the manner of crocodiles.

When the mouth of the young one is wide open, it will be seen that the tongue is arched directly upwards so as to form a compact valve, which prevents the water going down the gullet. The old father in the next den talks to his wife and child by means of sonorous gruntings, and they answer him. The father's face is much longer and sharper than that of his wife, and his eyes and nose are much more prominent. I understand from Mr. Bartlett, who kindly allowed me a private interview with the hippos, that another baby is expected about next April, and that Barnum is most anxious to obtain it. I doubt if he will; let him go and catch a wild baby hippo for himself."

#### Prismoidal Railway.

In our last volume, we gave a drawing of the Prismoidal Railway of Mr. E. Crew, of Opelika, Ga. Messrs. Lafferty Brothers, of Gloucester City, N. J., have lately constructed a four ton locomotive on this novel plan, which is thus described in the *Philadelphia Ledger*:

It is built for a street railroad company in Georgia. This engine can with propriety be called a velocipede, as it rests upon two wheels, one following the other. The rail or track upon which it is to run, a sample of which is laid in the yard of the builders, is styled a "Prismoid, or one track railway," and is composed of several thicknesses of plank, built up in the style of an inverted keel of a vessel, with a flat rail on the apex. Upon a trial of speed, about 13 miles an hour was attained, and the inventor and patentee claims that the speed can be almost doubled on a lengthened track.

Mr. E. Crew, of Opelika, Ga., is the inventor and patentee of both tracks and engines, and he claims that his inventions demonstrate a tractive power superior to anything in the locomotive line, of equal weight. The capacity for running on curves is very much greater than the two rail system. The track upon which the trial was made contained 36 feet of lumber and 18 pounds of iron to the lineal foot, proving itself equal to a span of 20 feet, remaining firm and unyielding under the pressure of the engine as it traversed the road. The revolving flanges attached to the engine, and which run on the outside of each wheel, Mr. Crew claims, absolutely lock the rolling stock to the prism, and obviate the necessity of so much heavy rolling

stock in light traffic at a high rate of speed. It is also claimed that a prismoidal railway built with a base of 14 inches and angles of 45° can be built at a cost of \$3,000 per mile.

The inventor is of opinion that his engine and track are particularly adapted to the propelling of canal boats, and will compete successfully with horse power on canals without necessarily interfering with the use of the latter, but he does not state in what way. The engine will shortly be shipped to its destination, Atlanta, Ga., where it goes into operation on a street railroad, built at an elevation of twelve feet above the sidewalk.

ELECTRIC INDICATOR OF VITIATED AIR.—A solution of palladium chloride is so connected with a battery that, as long as no metal is precipitated, no current passes; but as soon as carbon monoxide occurs in the atmosphere, metallic palladium is precipitated, which establishes a current, and rings a bell to give warning of the presence of the noxious gas.—*La Gaceta Industrial*.



MR. ROBERT CRAWSHAY OF MERTHYR TYDVIL, SOUTH WALES.

these gigantic creatures can lift their heads to the surface of the water. After she had finished her breakfast, Prescott, the keeper, enticed Guy Fawkes and her mother out of the water; the little one is as tame, playful, and docile as a kitten. We made her out to be about six feet four long, and two feet ten at the shoulders. Her back is a slaty black color, but her cheeks, chest, and legs are of a lovely pink salmon color. We calculated her weight to be nearly one ton, and her mother would make and weigh about three little hippos. She eats and sleeps well; and besides her natural nourishment, her meals consist of chaff, bran, mangold wurzel, scalded oats, biscuit, and sugar. She is very fond of anything sweet. She has already learnt to beg for food; she puts her head out between the bars, opens her mouth, and pricks up her little ears when she wants to beg. The gape of her mouth is about eighteen inches, she has already a most lovely set of white teeth, and the tusks begin to project out of her pink gums. Her mother is very watchful over her, and, if she thinks any one is about to disturb her child, hisses loudly like a big snake. Every morning



**FLAX AND ITS PREPARATION.**

It has been asserted that flax is, in Great Britain, the most profitable crop that an agriculturist can grow, and yet, of late, whole districts which used to be under this crop are turned over to other uses. There has been, as the *Practical Magazine* informs us in a thoughtful and exhaustive article, a great difficulty in finding machinery suitable for the preparation of the fiber (which needs the most careful treatment), capable of being managed by field hands. "Every farmer," says our contemporary, "ought to have his own scutch mill. The object to be aimed at is the economy of fiber. The saving of labor, the combination of more than one process in the same machine, and every other economic or mechanical desideratum ought to be secondary to the capability of the machine in clean scutching; in giving the largest possible yield of flax ready for the hackle from a given quantity of "mannered" straw. The system of scutch mills as we find them in Ireland is the best that has been adopted as yet. Hand scutching is too tedious, and the flax so manipulated can never be properly cleaned—short of an amount of labor which would add too much to the cost of production. But the scutch mill working for a number of farmers only suits Ireland, or elsewhere where the farms are small. In England and Scotland, where the farms are large, every farmer ought to have his own mill, either worked at the farmstead by the engine which works the threshing and other machinery of the farm, or by water power, when it may be had on the farm. The scutch mills ought to be in sets of three stocks, so as to give the flax the chance of "a buffer," "a cleaner," and "a finisher," to every streek. The "buffer" may be an unskilled man if only careful not to allow the "blades" to break his hand as he holds it across the stand of the stock. A careless scutcher will waste his wages in a quarter of any day he is allowed to work. The "cleaner" ought to be not only careful, but an orderly man. If flax is treated like hay, the loss is incalculable. Assuming that the man at the "rollers" has not allowed an uneven "beet" to pass through his hands, and has not made some stalks to ride on others before he presented the charge to the rollers, and that the "streakers" have done their work carefully, and that the "buffer" is not a slob, the cleaner will then be enabled to place the streek on the "finishing" board so orderly that not a fiber will be awry. The "finisher" must not only be a skilled laborer, but also an orderly minded man, possessing a good taste; and if he has those qualities he will show his pride in the orderly condition, the clearness from shove, and the general finish of every streek, which are necessary to good and economic scutching. But with bad machining, neither the "roller" nor the scutchers get fair play; and the owner of the flax pays for all in a serious curtailment of profits. The mill should go steadily whether by steam power or water power. The motive power should always be under such easy control that, according to the condition of the flax (hard or soft), the motion of the mill should be easily regulated."

We give herewith a self-explanatory view of a flax-breaking device which is now being introduced abroad for the purpose of enabling farmers to prepare this valuable but troublesome fiber for manufacturers' use. We believe that it will be of interest to the agriculturists in many portions of our country, who greatly need the introduction of a new industry. Possibly it may pay to grow flax in places where corn is burnt for fuel because it costs too much to get it delivered into the centers of population.

**THE OREODOXA REGIA PALM.**

The splendid and luxurious flora of Brazil produces nothing more graceful than the lofty palm known to botanists as the *oreodoxa regia*. Straight and slightly tapering for over sixty feet in height (when fully grown), the tree then separates into a frond of remarkable beauty, as complete in form as the capital of a Corinthian column. A grove of these trees (represented in our engraving) is to be seen in the public botanic garden at Rio de Janeiro, and it is difficult to imagine an object more beautiful to the eye of a lover of Nature. The trees are said to be between forty and fifty years of age. The trunk of each of them is about four feet in diameter at four feet from the ground, and it goes on tapering gradually to a length of more than fifty feet, when it becomes united with another smooth thinner trunk, from ten to twelve feet in height, formed of the bright green foot stalks of the leaves, which again measure some twenty feet or more.

In young vigorous trees the leaves are considerably longer. The great beauty of this palm is its elegance and cleanliness of aspect; no ragged leaf beats about in the wind, even at that great height; the over ripe yellow leaves unseath themselves of their own accord, and the trees look as clean as if they had been trimmed by hand. The color of the stem is a whitish gray, like that of light stone in dazzling sunshine; and although from top to bottom it is covered with lichens of all the colors of the rainbow, yet so small are they that you only perceive them by approaching the tree closely.

In the same grounds, says *The Garden*, to which we are indebted for the illustration, exists the parent of these palms, which was planted during the last year of the last

with the appearance of this avenue, which is unrivalled for its regularity, extent, and beauty. It forms a colonnade of natural columns, whose graceful bright green capitals seem to support an overarching dome of bright blue sky.

**Property in Patents.**

"The Nature of Property in Patents," was the title of an interesting society paper lately read by Mr. E. M. Quimby, of Orange, N. J., in which were set forth some of the difficulties attending part ownership of patents where there is no agreement regulating the use of the joint privilege, and the importance of preserving the title to the patent in its entirety demonstrated. Mr. Quimby thus formulated the legal question: "Patent property consists of an assignable privilege, having originally an exclusive character, which may or may not be preserved at the pleasure of the grantee. If the grantee assigns an undivided interest in his patent without the precaution of an agreement regulating the use of the privilege assigned, he by that act divests himself of the sole power of exclusion which he theretofore possessed, and the common property thenceforth is simply a common privilege, the free exercise of which by either part owner cannot be held to be an invasion or infringement of the rights of the other part owner."

Mr. Quimby suggested that the whole interest might be assigned to a trustee empowered and directed to administer the patent for the joint account of the several owners *pro rata*.

In discussing the moral effect and relative scope of patents for analogous inventions, it was remarked that the grant of a patent by no means establishes a commercial value for the invention, or even necessarily indicates that it may be used without invasion of the rights of others. To determine these points, it must be ascertained by further investigation whether the subject matter of the patent in itself infringes, or whether its use involves the concurrent use of devices which infringe upon principles claimed in prior existing patents, or described so as to be claimed in possible reissues of such patents.

**Slag as a Building Material.**

At a recent meeting of the Society of Engineers, London, a paper was read on the economic use of blast furnace slag, by Mr. Perry F. Nursey. The author commenced by noticing generally the history of the utilization of slag. In that condition it was first used for the beds in pig iron founderies, and afterwards in producing fine castings. It was also mixed with lime in certain proportions, and then pressed into bricks and made into concrete and cement. Slag sand was also used in making mortar with very good results; it was further utilized as ballast on railways, and had also been adopted in the manufacture of glass. In England, the author stated, it had also been similarly applied, and systems of machinery for its utilization had come into practical operation. The machinery of Mr. C. Wood, of Middlesborough, and of Messrs. Bodmer, of Hammersmith, was then described by the author by the aid of diagrams and models. Mr. Wood's machines, he explained, were of two kinds, one of a horizontal revolving table, and the other a vertical revolving drum. By the first machine the slag was cooled with a stream of water as it left the furnace, and, becoming disintegrated, was broken up and pushed off the table at a certain point by scrapers into trucks placed beneath. In that state the material was in a suitable condition for making concrete for building purposes. The second machine was for reducing the slag to a finer condition. It was run from the furnace into the drum, through which a stream of water flowed. The drum had screens placed within it, and as it revolved the slag became reduced to a fine sand, and was delivered in that condition into trucks. The sand was utilized in making bricks, cement, mortar, and for other similar purposes. Messrs. Bodmer's plan consisted in the use of a pair of rolls, through which the slag was run from the furnace on to a traveling band, which delivered it wherever required. The sheet of slag thus produced was readily broken up for use in concrete-making or ground into powder for bricks, cement, or mortar. For some purposes Messrs. Bodmer ran the slag into water, but for bricks and cement they produced it dry. They had also a special system of machinery for the manufacture of slag bricks, which was worked by hydraulic power, and which was described by Mr. Nursey. Samples of sand produced by both processes were exhibited, as were also bricks, concrete, and cement made from them. The satisfactory results which the author showed had followed the extensive use of blast furnace slag in the form of building materials leads to the hope that the enormous heaps of slag in the iron districts will become a source of profit and will provide good sound building materials at a low cost.

**FLAX BREAKING MACHINE.**

century, and is now above 120 feet in height. It is a noble tree, and, as it stands singly and at a considerable distance from other plants, its beauty and height can be seen to the best advantage.

Strangers from northern countries are invariably struck

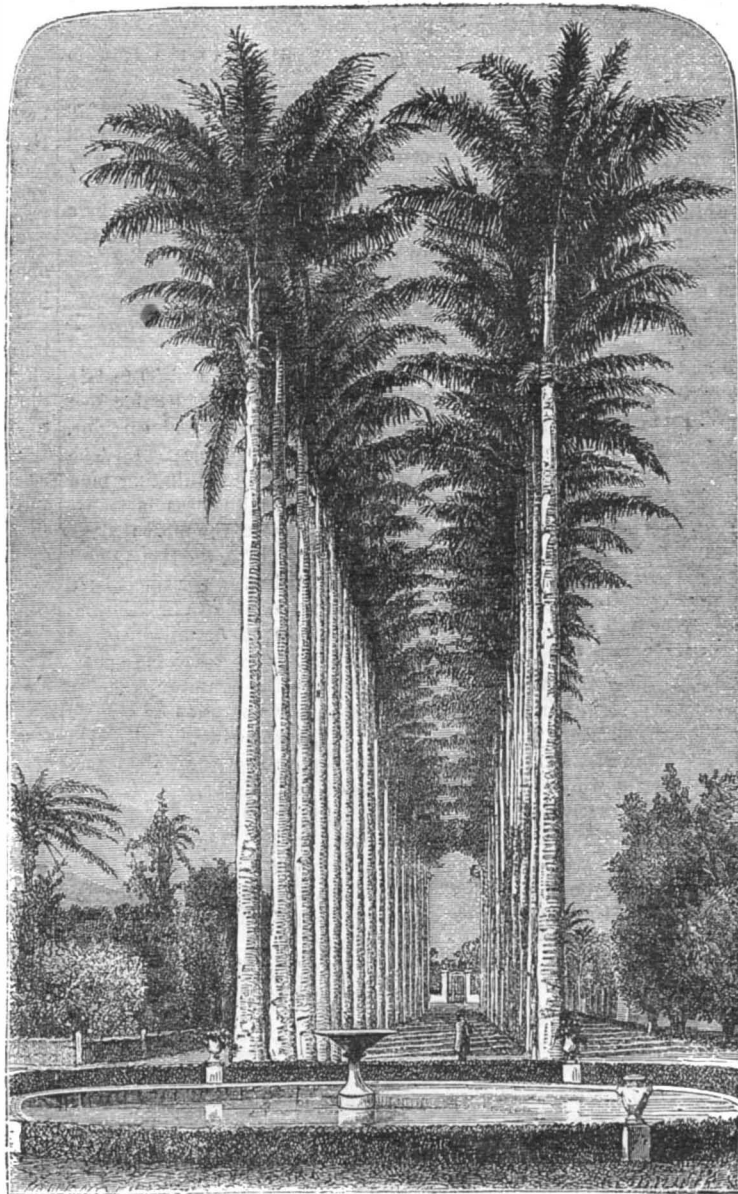
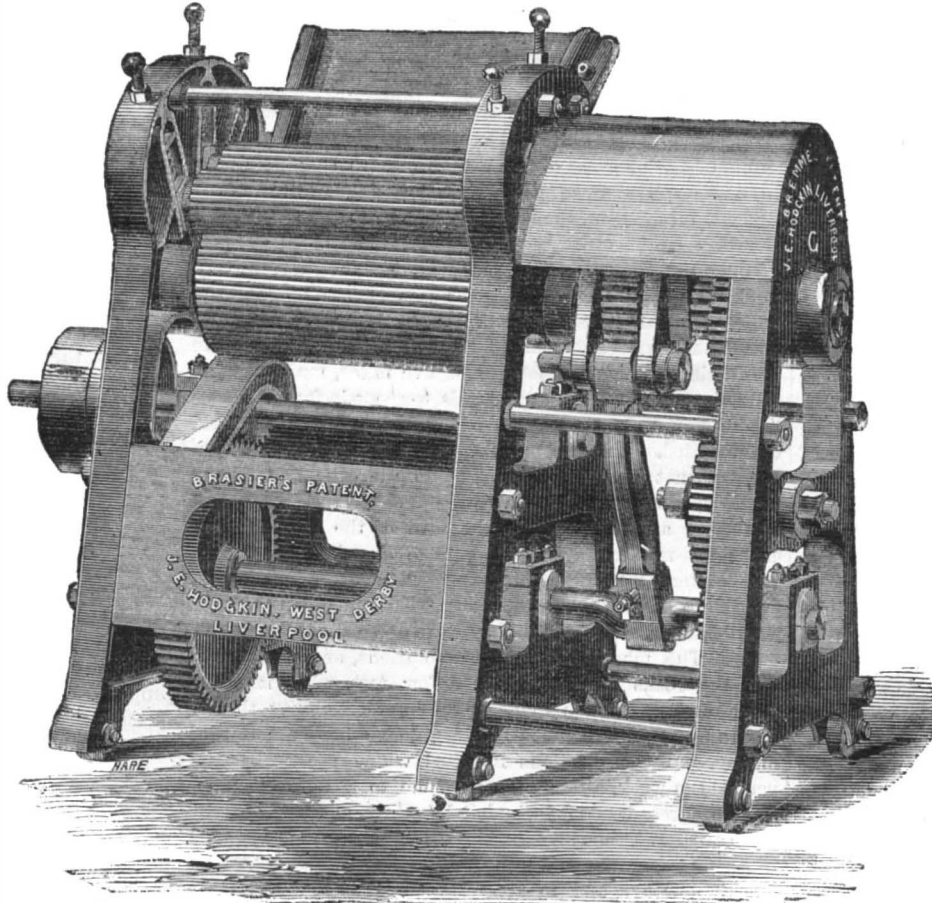

**THE OREODOXA REGIA PALM TREES.**

## Correspondence.

## Electricity vs. Yellow Fever.

To the Editor of the Scientific American:

I have been an observer, since the epidemic of 1853, of certain phenomena for which I am unable to account, not being a scientist; and I will therefore recount my observations for the benefit of others. I have observed that, for some time prior to the breaking out in southern latitudes of the terrible scourge of yellow fever, rains fall, unaccompanied by thunder and lightning. During the prevalence of the epidemic, lightning is scarcely ever seen, no matter how often it may rain. The weather may be cloudy ever so long, yet the rains are not accompanied by the lightning flashes and thunder peals ordinarily common in this latitude (31° N.). When no yellow fever visits this portion of our country, thunder and lightning accompany every rain. There was, about in the middle of September of this year, one peal of thunder heard in this county (Jefferson) and in Stow county, Miss.; and none from then till the evening of October 26 following. We never have a killing frost, that is, one that destroys all the vegetation liable to be killed, till after a rain accompanied by a good deal of lightning. In 1855, in the county of Madison in this State, I remember that, at an examination of a female school in July of that year, there could not be generated a sufficient amount of electricity to perform the simplest experiment with the electrical apparatus. The yellow fever made its appearance shortly thereafter in the town of Canton, and raged terribly.

I have drawn this conclusion from the facts that yellow fever does not prevail when the atmosphere is charged with electricity; and when it does prevail, there is an absence of that subtle fluid. May not scientific men be able to treat yellow fever cases electrically? As to the *modus operandi*, I have nothing to say; but it strikes me as being reasonable that there is some property in electricity antagonistic to yellow fever or the miasm that produces it; and if electricity can and does destroy the germ of that fatal disease in the atmosphere, why may it not do the same in the patient afflicted with the virulent poison?

I make these suggestions hoping that scientific men may give the subject investigation; and if there be anything beyond mere coincidence in the facts as above stated, electrical statistics will be able to verify it, if a call be made upon those whose duty it is in the various localities to note the changes of the weather.

OBSERVER.

Fayette, Miss.

## Trees as Historians of the Past.

To the Editor of the Scientific American:

It may have taken a French savant years to ascertain what is a matter of common knowledge with wood cutters. I have understood for more than 30 years that a thin ring indicated a cold season, and a thicker one, a corresponding warm season. Another point which I have observed (and which is not mentioned in the Gros article) is this: In trees that are in an open field, or even in the forest where there is no particular protection from the north wind, the rings will be thinner on the north side than on the south side of the same tree. The heart of the tree is very seldom found in the center of the body. I have no doubt that you would find that a tree cut 4 or 5 feet from the ground will give a true record of the general meteorological conditions of each year of its life. I have often sat down by a newly cut stump of a tree, to count the rings, to note the difference of thickness, and to point out the thin rings to those with me, as indicating a cold year.

While speaking of trees, I will mention another fact, which I have not seen in print, but which I got from an old gardener. It is that all trees that are not trained out of natural shape will exhibit a profile in exact correspondence with the fruit. For extremes, take the greening apple and a long slim pear. The leaves, even, have a general resemblance to the fruit.

A. M. W.

Bridgeport, Conn.

## Snake Poison.

To the Editor of the Scientific American:

With reference to the article published in No. 3 of your current volume, I wish to mention that the poison of the rattle snake (*cobra cascavel*) has been used in this country for about 20 years by several physicians, upon the homoeopathic principle, under the scientific name of *crotallus cascarella*, and with very good results, chiefly against neuralgic complaints and against nervous trembling. It is described as a most powerful specific in such cases, and to operate with great rapidity.

Th. T.

Pernambuco, Brazil.

## Prizes for Scientific Experiments.

The following subjects for prizes to be awarded in 1874 have been proposed by the Batavian Society of Experimental Philosophy:

1. To discover if there exists, in the molecular state of bodies, modifications other than those caused by temperature, which are such as to give for the same body different spectra. The society wishes that this inquiry should bear chiefly on the magnetic condition of bodies.

2. To find out by new experiments if the vapor of water exercises on radiant heat an absorbent effect much more powerful than dry atmospheric air, as Mr. Tyndall maintains; or if there exists no difference in this respect between dry and moist air, as M. Magnus maintains. The society desires that the new experiments which it asks for be conclusive, and enable it to decide between the two opinions.

3. To determine what influence the pressure which is put upon an electrolyte has on electrolysis, and how far in this case is the principle of conservation of energy confirmed. It is wished that this inquiry bear on three liquids at least, to be chosen by the competitor.

4. To determine the resistance of the liquid amalgams of zinc and gold to the galvanic current. Six at least of each of these amalgams, in various proportions, ought to be examined.

5. A prize is proposed for new experiments which will enable a certain decision to be come to on the opinion, advanced by M. Gaugain as probable, namely, that voltaic electricity is propagated by matter, while induced electricity is propagated by ether.

## COMPLETION OF THE HOOSAC TUNNEL.

It is with much pleasure that we chronicle the completion of the bore through the Hoosac Mountains, Massachusetts, which work was accomplished on the 27th of November. The back volumes of the SCIENTIFIC AMERICAN contain accounts of the progress of this great work from its incipency up to its completion, together with engravings of the various kinds of mechanism, that have, from time to time, been employed.

When the Hoosac Tunnel was authorized, no such railway work of equal magnitude had ever been undertaken, and the project seemed almost impracticable, for lack of suitable mechanical means. The method of hand drilling through the mountain rocks, for a distance of five miles, made the job seem almost interminable; and calls were made for the invention of new and special machinery, whereby the work could be expedited. This was in 1858. The ingenuity of the Yankee was not long in responding to the call; and in the course of a few months, the contractors had the satisfaction of setting at work, against the face of the mountain, an enormous machine composed of a great wheel faced with steel cutters, by which they expected, at one operation, to cut a finished tunnel of twenty-five feet diameter in the most rapid manner. But in this they were doomed to disappointment. The machine began its revolutions, and cut its way into the rocks very nicely for a few feet, when it broke down, and gave such evidence of impracticability that it had to be abandoned. The builders lost a large amount of money, and complications followed which practically suspended the work, although, from time to time, up to 1868, some progress was made by hand drilling, and paid for by State funds. Other inventors had in the meantime succeeded in constructing new and improved drilling machinery, of an effective nature, and in 1868 Messrs. W. and F. Shanly signed a new contract, guaranteeing to complete the tunnel by or before July, 1874. They set vigorously to work, employed the pneumatic drilling machinery, and have now successfully pierced the mountain. Their portion of the work will be finished in advance of the period fixed by their contract.

The work extends from the Hoosic river, at North Adams, Mass., on the west, through the Hoosac Mountain to the Deerfield river on the east; and when completed, will open a new line of railway travel, by easy grades, from Boston and the northerly portions of Massachusetts to the Hudson river.

The tunnel has a length of 25,031 feet. Its dimensions are 24 feet in width and 20 feet in height above the railroad track when laid, with a central covered drain two feet square. Its form is a rough semicircle, the variation being such as to give greater height at the sides than could be given by a true semicircle. It has cost, principal and interest, a little more than \$12,000,000.

## IMPROVEMENTS IN THE VENTILATION OF THE UNITED STATES SENATE CHAMBER.

The Senate chamber is 113 feet in length and 80 feet in width, by 36 feet in depth, which gives 325,440 cubic feet in solid measure. The galleries, coat rooms, and corridor, however, reduce its capacity to 250,000 cubic feet. The proper ventilation for this apartment, where thinking men sit through long sessions and important business is transacted, has been deemed a matter worthy of the most serious consideration. Previous to November, 1870, the Senate hall was ventilated in the ordinary way, and was excessively bad. Persons with weak lungs found it impossible to breathe the poisonous atmosphere for the few hours occupied by the daily sessions, without headache or more serious indisposition. A new system for ventilating this chamber was devised, and has been gradually put into operation by Mr. H. F. Hayden, Chief Engineer of the Senate wing. A description of the old method and the new will perhaps be interesting to builders and designers of public halls.

The apparatus, as first constructed and operated, for heating and ventilating the chamber, worked by drawing in a quantity of external air by means of a fan, and passing it over coils of pipe heated by steam, then forcing it into the chamber through risers and registers in the floor. It was supposed that the impure air would be forced out through the doorways and opening in the ceiling, by the continuous flow of air. No exhausting power was employed to assist in its removal.

The forcing fan for the chamber is 14 feet in diameter, and is moved by an engine of 16 horse power, will deliver 500 cubic feet of air at each revolution, and is capable of being run up to 80 revolutions per minute, which is the maximum velocity for summer ventilation. But owing to defects and contraction of the main air channel and the various avenues for ingress of air, the quantity of fresh air demanded for healthful ventilation could not be supplied without pro-

ducing powerful currents on the floor. Therefore the speed of the fan had to be reduced accordingly, which gave only about one fourth the quantity of pure air required. The first improvement was the introduction of two large fans in the basement, and an engine of 25 horse power to operate with them for the removal of vitiated air at the ceiling, by exhaustion. The fans referred to are capable of removing 30,000 cubic feet of air per minute, when run at ordinary speed. The vitiated air is drawn through the perforations in the ceiling into the illuminating loft above, then through two descending shafts into the exhaust room, and discharged by the fans into an ascending one leading to the open air. The capacity of the descending shafts is 36 superficial feet. Both the descending shafts and the ascending one are of equal capacity. It will, therefore, be seen that, if the supply of pure air had been equal to the amount that could be removed, the entire atmosphere in the chamber would have been changed once every ten minutes. But the pressure of the air in the chamber was reduced on account of an insufficient supply, and the impure air from the surrounding corridors was drawn in through the doorway to make up the deficiency. A new air shaft of ample dimensions has been constructed, leading from the heating chamber in the basement to an air space under the seats in the galleries. The seats and risers of the same have been freely perforated, so that nearly three fourths of the supply will enter without causing injurious currents. This air can be tempered independently of that for the floor, so that, when the chamber is crowded, the temperature can be regulated to any degree desired. Another improvement is in the construction of a vaporizing apparatus in the main air duct, by which the proper amount of moisture can be added to the supply of air, after it has been heated, and the amount of moisture is regulated by hygrometers placed in the chamber. The inlet for fresh air for the hall was located between the wing and the old Capitol. Coal gas and smoke from the flues above were often forced down by counter currents, and carried into the chamber by the supply fan. At the suggestion of the engineer, a resolution was offered in the Senate last winter to extend the inlet from the Senate wing to the Western Park, a distance of 220 feet. An appropriation was made for the proposed improvement, which will be completed before the meeting of Congress. The air for the chamber will then be drawn from the level of the Western Park into a clean passage, coming in contact with nothing that can vitiate its purity until it has performed its functions of ventilation. It has been fully determined, by experiment, that with the present arrangements 30,000 cubic feet of pure and well tempered air can be supplied per minute, and ample provision be made for its diffusion: which is 25 cubic feet per minute for each individual, assuming the number of persons in the chamber to be 1,200. The efforts that have been made within the past three years by the engineer to improve the ventilation of the Senate chamber, have not been based on theory alone, but on well established principles, which experience and observation have rendered necessary.

The improvements here referred to will be readily understood by referring to page 73 of our last volume, where a diagram of the Capitol, in elevation, is given.

## THE USES OF NICKEL.

The manufacturers of the alloy known as German silver have recently submitted a petition to the Parliament of the German Empire, praying against the introduction of nickel money into that country. They state that the cost of nickel has increased at the rate of from one to three dollars, and that German silver in a single month has gone up nearly \$12 per 220 pounds. In England, the price of the metal in one year and a half has risen from one to four dollars per pound.

Although but a short time has elapsed since nickel has attained any important position in the industrial arts, it is already a fact that the demand is considerably in excess of the supply. The annual production may be roughly estimated in the neighborhood of 600 tons, of which aggregate English industries alone, it is stated, use fully one half. It is used as money in this country, Belgium and Switzerland; and hence it is argued, with much truth, that if Germany should decide to issue a similar coinage, the necessary drain upon the supply would seriously affect the manufactures in which nickel is employed. It is very probable that abundant uses could be found for quantities far exceeding the amount now produced. In its resistance to tensile strain it is nearly one third superior to iron, a metal which in many respects it has similar features, while it is much less subject to oxidation in air or water. German silver, as is well known, is nothing more than brass to which one sixth or one third part nickel is added, in order to give the alloy the color of silver and at the same time a superior resistance to the action of various chemical agents. The alloy is superior to copper as a basis for silver-plated ware, as, when the deposit of silver wears away, it does not expose a red or yellow metal beneath. German silver has also been lately used as a deposit upon other substances; an employment to which it bids fair to be largely devoted.

The increasing demand for nickel will doubtless stimulate research for new deposits; but until such are discovered, it seems desirable that the metal should not be used for coin. Some idea of its rarity may be obtained by comparing the production as above given with the amounts of other metals. Thus copper, for example, is mined to the extent of 65,000 tons per year, and the iron production, it is said, reaches the enormous aggregate of 10,000,000 tons in the same period. Platinum is obtained probably in smaller quantities than any metal in industrial use, only about two tons being the yearly yield throughout the entire world.



## THE SAVINGS OF SCIENCE.

Doubtless many of our readers have perused Dickens' excellent novel "Our Mutual Friend," and hence are, in a measure, familiar with the London dust heaps. Perhaps it will be remembered how the great writer describes their contents, and, in his inimitable style, sketches the queer people who often spend their lives among them in seeking for treasures. Those patient searchers are creations of the past, their toilsome occupation is gone; for Science, with her inventions and processes, has extended her sway even to the worthless dust heaps, and from the filthy waste brings out the shining gold. The ordinary waste of a single household may be roughly estimated at a barrelful per day, and London, it is said, contains five hundred thousand houses. Hence, the reader may form some idea of the wonderful ingenuity which contrives to utilize the enormous aggregate of one hundred and eighty million barrels of refuse in the course of a single year.

The local authorities of London sell the privilege of removing dust and garbage from each district to a contractor, who carts it away to a large yard in the suburbs. There hill women, sieve in hand, separate the mass, by a rude analysis, into component portions. The most valuable of the latter are the waste pieces of coal, and the breeze or coal dust and half burnt ashes. The amount of waste of the latter may be measured by the fact, that, after selling the larger pieces to the poor, the refuse breeze is sufficient to bake the bricks that are rebuilding London. The material is used by the contractors who generally combine the builder's trade with their regular calling, for the purpose of imbedding the newly made bricks into compact squares. The coal dust having been fired, the mass burns with slow combustion for two or three weeks, aided by the circulation of air which is kept up by the method of stacking. The other constituents of the dust heap are separated by the sifters with the utmost rapidity: bones, rags, paper, old iron, glass, and broken crockery, and even bread, as they are eliminated from the mass being piled in separate heaps. The bones are put to a score of different uses. Of the several tons of bones that are picked out of the dust in the course of a week, some go immediately to the boiling houses, where every portion of fat and gelatin they can yield is extracted; the former substance is bought by the soapmaker, the latter is utilized to make the patent preparations employed in cookery, photography, etc. The larger bones are used by the turners and are converted into hundreds of knick-knacks, so that the bone you may have picked at dinner again enters your mouth, after many changes, as a toothpick or toothbrush, while the smaller pieces, for aught you know, have been calcined, and form the very charcoal toothpowder on your toilet table. Fragments that cannot otherwise be employed are ground very fine, and treated with sulphuric acid, constituting an excellent artificial fertilizer. Bone dust is also sometimes used by bakers for purposes of adulteration, so that the poetical remark of the giant in the fairy tale,

"I'll grind his bones to make my bread,"

is fulfilled both figuratively and literally. Another important product extracted from bones is phosphorus, for which there are an endless number of uses; and, finally, the fat that is saved in the process of boiling, is employed to make the commoner kinds of soap.

Scraps of paper abound in the dust heaps. These are all carefully sorted, the white from the colored and the printed. The soiled pieces, which cannot be profitably remanufactured, are used to make *papier maché* ornaments, dolls' heads, etc.; the clean paper is returned to the mill, and even the printed paper has the ink discharged from it, and goes again into circulation. Old rags, of course, are valuable to the paper maker, although the discovery of other materials renders this form of waste not quite so important as formerly. Greasy dish cloths cannot go to the mills again, so they are sent to the hop grower, to whom they are valuable as fertilizers. Woolen rags, if they happen to be dyed scarlet, are treated for the recovery of their cochineal, which is used as a dyeing material; and other valuable colored rags are ground up to make flock paper.

The great markets for all old woolen fabrics in England is the town of Batley and its neighborhood, in Yorkshire, the great shoddy metropolis. A writer says, regarding this manufacture: "Reduced to filaments and greasy pulp, by mighty toothed cylinders, the much vexed fabric re-enters life in the most brilliant forms, from the solid pilot cloth to silky mohairs and glossiest tweeds."

Cotton and woolen rags are both valuable when separate, but of late years it has been the custom to weave the cotton and woolen together, the warp being made of the latter material and the weft of the former; thus mixed, however, the fabric cannot be converted into paper or cloth. Many endeavors have been made to effect a separation, and at present the rags are placed in a closed receiver and subjected to steam at a very high temperature. The result is that the cotton comes out pure and fit for the paper maker; the wool is reduced to a dark brown powder, known as the ultimate of ammonia, and is employed to enrich manures which are poor in nitrogen.

A very important constituent of the dust heap is the old iron, battered saucepans, old pails, rusty hoops, horseshoes, and nails from the road. All soldered articles have the solder extracted from them, as it is more valuable than the iron, and the cheaper metal is then melted. The horseshoe nails are not mixed with the common cast iron, as they are much sought after by gunmakers for the purpose of making stub twist barrels. Scraps of iron, it is found, may be made very useful in securing the copper in the streams washing veins of copper pyrites. Pieces of battered iron are placed in tanks, into which these are collected; the copper quickly

incrusts the iron, and in process of time entirely dissolves it, so that a mass of copper takes the place of the iron. The residuum, in the shape of a colored deposit, is at times taken out, dried, and smelted.

The savings of science, however, are not all made in the dust heaps of London, though in the brief outline we have given, of the mode of utilizing some of the constituents of the waste of the great city, a vast economy is indicated. A singular and recent French discovery is that sheep draw a considerable quantity of potash from the land on which they graze, much of which is ultimately excreted from the skin with the sweat. It was pointed out by Chevreul that this peculiar potash compound (*suint*) forms no less than one third of the weight of raw merino wool, while of ordinary wools it constitutes about 15 per cent of the weight of fresh fleece. As the *suint* may be extracted by mere immersion in cold water, it is easy for the manufacturers to produce more or less concentrated solutions from which the potash may be recovered by appropriate treatment. The development of this new industry is principally due to MM. Maumène and Rogelet, and their process consists in evaporating the solutions, which are sent to them, until a perfectly dry and somewhat charred residue has been obtained. This is placed in retorts and distilled very much in the same manner as coal at gas works, and the result is that, while much gas is evolved which can be used for illuminating the factory, and much ammonia is expelled which can be collected and utilized in many ways, there remains a residue which chiefly consists of carbonate, sulphate, and chloride of potassium. These three salts are separated by the usual method, and then pass into commerce. Curiously enough, they are remarkably free from soda.

The wool manufacturers of Rheims, Elbœuf, and Fourmies annually wash the fleece of 6,750,000 sheep, and the amount of potash, reckoned as carbonate, which these fleeces would yield if all were subjected to the new process, represents a value of \$400,000. The by-products of gas works are so valuable now that factories are actually set up beside such establishments for their utilization. The most important is alum, which, like sal ammoniac, once came, at a great cost, from Egypt, but is now mainly procured from an aluminous shale, which forms the roofs of coal mines, and which has to be brought to the surface before the coal can be gained. This was for a long time a perfectly refuse material, covering acres of ground, like the scoriæ and cinder heaps; but chemistry has found it out, and now obtains the product by setting fire to the shale, the carbon and sulphur which it contains being sufficient for the purpose. The friable porous residua are afterwards heated in iron pans with sulphuric acid, to which is added the ammonia from the gas liquor, and the three bodies combine with water to make common or ammoniacal alum.

Nearly every article of the toilet bottle or the *sachet* is made from waste, sometimes from foully odorous matters. A peculiar fetid oil, termed fusel oil, is formed in making bandy and whisky. This fusel oil, distilled with sulphuric acid and acetate of potash, gives the oil of pears. The oil of apples is made from the same fusel oil by distillation with sulphuric acid and bichromate of potash. The oil of pineapples is obtained from the product of the action of putrid cheese on sugar, or by making a soap with butter and distilling it with alcohol and sulphuric acid. Oil of grapes and oil of cognac, used to impart the flavor of French cognac to common brandy, are little else than fusel oil. The artificial oil of bitter almonds is prepared by the action of nitric acid on the fetid oils of gas tar. The wintergreen oil of New Jersey is artificially made from willows and a body procured from a distillation of wood.

Dyes, like perfumes, are often derived from the most repulsive sources. The waste heaps of spent madder were formerly a great nuisance. It is now found that this hitherto waste can be used, and at least one third can be saved by treating it with hot acid. Prussian blue is made from pieces of horse hoofs or refuse woolen material by fusion with iron and alkali.

Perhaps the most important refuse product that can be mentioned, as proceeding from a systematic manufacturing process, is that known as soda waste. Large quantities of this substance are rejected as useless by most alkali works, and it has been, for many years, a problem and a reproach to chemistry. It is a great loss; and, if we can but recover it, no small victory will be achieved.

## Dry Plate Photography with Gelatin.

Place seven grains of Nelson's gelatin and seven grains of isinglass in cold water for several hours until soft and swollen; then drain off the water, and put them into a two ounce bottle, which place in hot water until the gelatin and isinglass are dissolved. Add thirteen grains of bromide of potassium, dissolved in a dram of distilled water; and in another dram of distilled water dissolve fourteen grains of nitrate of silver, and add it by degrees, in the dark, shaking well between each addition. Now add half a dram of a saturated solution of nitrate of baryta, and two drops of muriatic acid. There will be a froth on the top of this emulsion from the shaking, and in order to get rid of this it may be strained through muslin; or, if left in the hot water, it will gradually subside.

This will form sufficient emulsion, at a cost of about two-pence, to coat over one dozen quarter plates, which, as coated, should be laid on a flat surface until the film sets, which will take about five or ten minutes, when they can be put away in a box to dry. The drying will take about forty-eight hours (unless they are placed in a current of dry air), or they may be exposed at once. An exposure of thirty seconds, with alkaline developer, should give a negative of sufficient

printing density without any intensifying. The plates should be placed in cold water for about a minute previous to developing.

Emulsions prepared with the silver in excess caused the plates almost surely to fog, and the image to be very thin and faint.—*Br. Jour. of Photo.*

## The Tricks of Magic.

Professor Hartz, the magician, has lately been giving a series of performance here, some of which are as surprising as they are entertaining and amusing. One of them is as follows: A common empty packing box, with a lid hung by iron hinges, is placed upon the stage, and a committee from the audience asked to examine it. They report that it is a firmly made packing box. After a thorough examination, outside and inside, they take a rope and tie it up, passing twice around the ends and sides, passing it through the staples for the two padlocks, and then tie the ends firmly, and seal them with sealing wax. They then envelop the box in a canvas, which covers all six sides, when another rope is added, tied and sealed. Surely the box is safe from any attempt to get into or out of it without removing the ropes!

Professor Hartz's assistant then comes forward with a canvas sack, open at one end. This is examined by the committee and by the audience. It is then placed over the head of the assistant, and tied below his feet and the knots sealed. He is then laid on the box, and the box surrounded by a screen. In two and a half minutes the sack is thrown over the screen, the knot and seals untouched. The screen is instantly removed, and the committee, after examining the seals and finding them unbroken, commence untying the ropes and removing the canvas. The box is opened and the man found inside!

## Reward Offered for Improved Cattle Cars.

The Committee of the Royal Society for the Prevention of Cruelty to Animals, London, in order, if possible, to mitigate the cruelty to which animals are subjected in railway carriages during their transit from place to place, offer a premium of \$500 for a new cattle truck; also a premium of \$500 for alterations of, or additions to, cattle trucks at present in use; also an additional premium of \$500 to each prizeholder, so soon as he shall have induced a railway company to build fifty of his improved trucks, and to bring the same into actual use on their line for the transport of cattle.

The other conditions are that the improved truck shall be suitable in gage, dimensions, construction, material, etc., for the same purposes for which cattle trucks are now used; the truck shall be roofed, and provided with springs, buffers, and axle springs, or other appliances to prevent injuries to animals during shuntings and sudden startings and stoppages. The truck shall be provided with appointments for the supply of food and water to animals in the carriage during the time when the train is in motion or when it is stationary at a platform or siding, so as to avoid the necessity of removing the animals from the truck for refreshment; the cost of the truck shall not be greatly in excess of the cost of cattle trucks now in use; and the truck shall be satisfactory to the judges.

The limit of competition is for December 1, 1873, and unless the time is extended, American inventors will not be able to compete. But the publication of the offered reward will be of interest as showing a special call for improvements.

## Rheumatism.

A correspondent in the *English Mechanic* gives the following remedy for curing rheumatic gout, of which he had long been a sufferer. He insulated his bedstead from the floor, by placing underneath each post a broken-off bottom of a glass bottle. He says the effect was magical, that he had not been free from rheumatic gout for fifteen years, and that he began to improve immediately after the application of the insulators. We are reminded, by this paragraph from our English contemporary, of a patent obtained through this office for a physician some twelve or more years ago, which created considerable interest at the time. The patent consisted in placing glass cups under the bedposts in similar manner to the above. The patentee claimed to have effected some remarkable cures by the use of his glass insulators, but we have not heard from him for some time. We cannot vouch for any merit in the idea, but it is one easily tried; and as no harm can arise from the experiment, we hope some one will test it and give us the result of his experience.

## Tongueless Speech.

The reputed miracle wrought in the case of the African Bishops and certain other Christian martyrs, who retained the power of speech after having their tongues cut out, has lately been the subject of a somewhat heated controversy. The fact of their being able to speak after they had lost their tongues was not questioned; it was only claimed that there was no miracle in the matter, or anything to warrant the inference of Divine interposition because of their peculiar sanctity. They may have been most worthy characters, but their tongueless speech was no proof of such a fact, since the same phenomenon had been observed where there could be no claim to saintliness.

An interesting illustration of the truth of the latter position has just occurred in the Royal Free Hospital in London, the case being reported in the *Lancet* for November 8. To remove a cancerous ulcer, a patient's tongue was wholly cut out, leaving the floor of the mouth entire. Recovery was rapid, and within a week the patient could speak with sufficient distinctness of articulation to make himself understood, saying: "I feel easy," and "I should like some more beef tea."

**COMBINED SNOW AND EARTH SHOVEL AND PLOW.**

An efficient railway snow plow, by means of which a locomotive may be enabled to push its way through heavy drifts, is unquestionably an invention for which there is a great necessity. Not a winter passes but that scores of trains are blockaded, and hundreds of passengers subjected to prolonged inconvenience, by the tedious delay incident to digging out the tracks by hand shovels; while, in some instances, as that of a construction train on one of the Pacific railroads last year, people are placed in actual peril from starvation or continued exposure to the inclemency of the weather. Snow plows of the ordinary construction are moderately efficient in light drafts; but when attempts are made to force them through banks that have become packed or heaped up by the wind as high as the body of the locomotive itself, they speedily prove their inadequacy for the severe work.

The apparatus to which our engravings refer is claimed to combine the advantages of both plow and shovel, together with the merits of efficiency, simplicity, and cheapness. Its especial adaptation is to clearing snow from tracks, but we are informed that it may also be used in loose sandy soils for removing earth in the construction of railways, or for taking up snow from street car rails in cities, and carrying the same to a convenient dumping place.

Fig. 1 represents the device attached to a locomotive and in action. From Fig. 2 a clear idea of the working parts will be obtained. A is the shovel, the bottom of which is made slightly wider at the rear than in front, and which is provided with flaring sides. The front edges of the latter, as well as the corresponding portion of the bottom, are plated with steel. B is a truck which supports the rear part of the shovel, the front portion of which rests upon steel shoes, C, which fit over the rails. At D is the plow, the shape of which is clearly indicated, provided on each side with a cleat, E, running in a groove formed in the side of the shovel, so that it is thus prevented from being raised up by the snow or other cause when being pushed back or pulled forward. To the under side of the plow is secured a rope, F, which runs forward in a groove in the bottom of the shovel over a pulley, and thence back under the shovel to the engine.

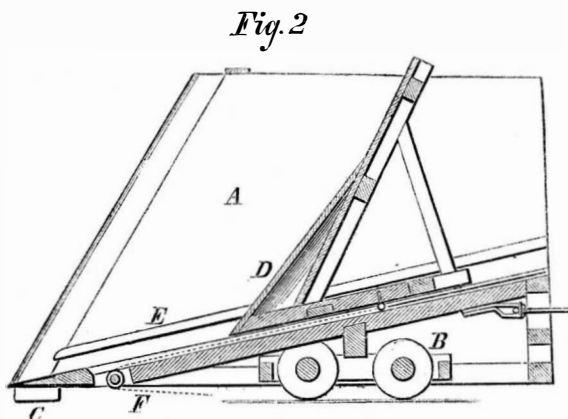

Ordinarily, the track being clear, the weight of the apparatus is borne by the truck, B, and the front end of the shovel does not touch the rails. As soon, however, as a drift is encountered, the snow presses down the shoes, C, raising the shovel almost off its truck, and guiding it into the bank. When the locomotive stops and immediately begins to back out, owing to the latter movement, the rear end of the apparatus settles down, thereby raising the front extremity sufficiently to break off and detach the snow in the shovel from the drift. The backing continues until a suitable point is reached, at which the contents of the shovel are discharged: as while this retrograde motion is in progress, the rope, F, connecting with a ratchet wheel on the front axle of the locomotive, is being pulled, thus drawing the plow along to the front of the shovel, and, of course, forcing the contents of the latter out upon the track. The engine then starts forward, when the plow, now in front, throws the snow clear of the rails. The drift is then again butted, when the snow pushes the plow back in the shovel to its original position (or the plow can be drawn back by a reverse tension of the rope, F), and the same operation is repeated until the obstacle is overcome.

A suitable jet of steam or water, sufficient in freezing weather to form a coat of ice, may, it is stated, be arranged in connection with the inside of the shovel and with such parts of the plow as come in contact with the latter, in order to facilitate the action of the plow in forcing out the snow.

The dimensions of the apparatus are 16 feet high, 23 feet long, and 10 feet wide; and allowing for the space occupied by the plow at the back, it has a cubic capacity of 3,500 feet. As the machine compresses the snow while excavating this large quantity at every ram, it is probable that there are few snow banks which it would not speedily demolish.

Patented July 8, 1873. For further particulars relative to sale of rights, etc., address Lieutenant Colonel W. F. Baker, Decorah, Winneshiek county, Iowa.

**To Clean Files.**

A correspondent, L. D. D., sends us the following recipe:

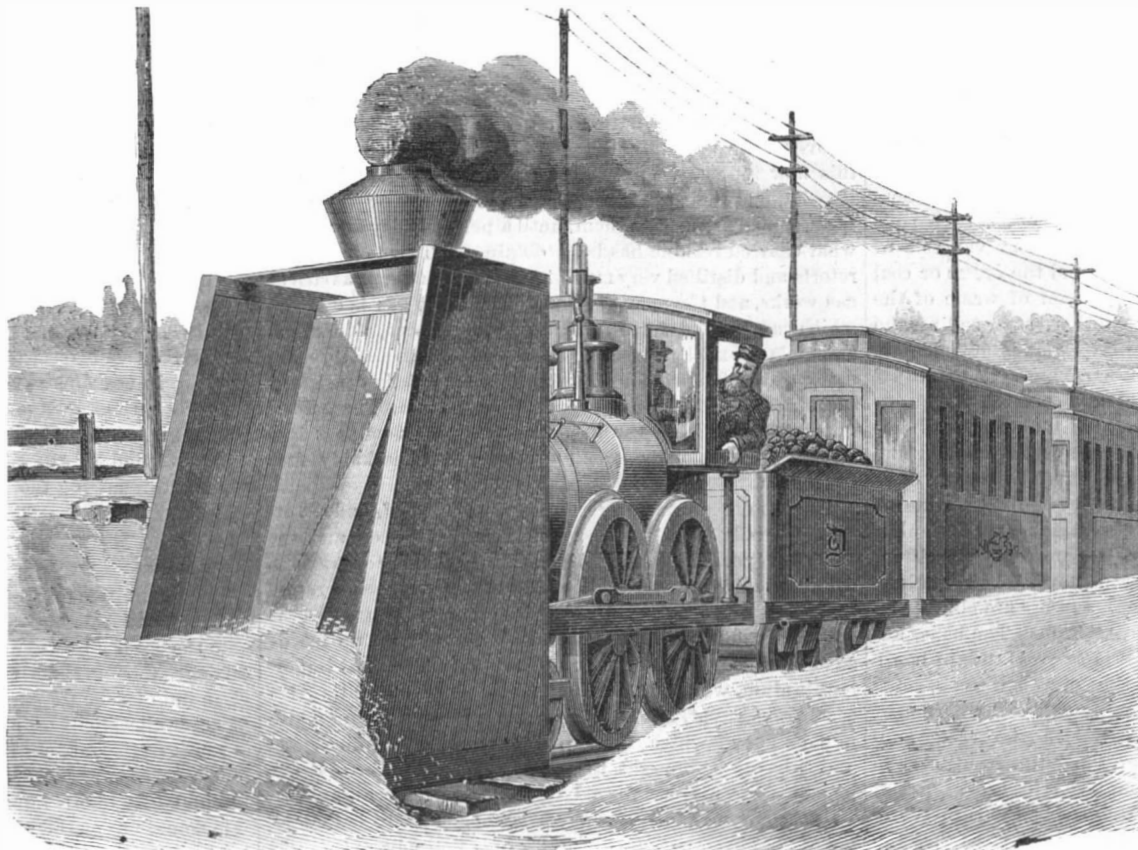

**COMBINED SNOW AND EARTH SHOVEL AND PLOW.**

"Boil the files in a solution of water and saleratus until they are thoroughly cleansed of outside dirt; after which, wash them in warm water. Put a pint of warm water in a wooden dish, in which stand as many files as the water will cover. Add to this, 2 ounces of borax and 2 ounces of blue vitriol finely pulverized together. Stir up the files well, and add 2 ounces of sulphuric acid by weight, and then 1/4 ounce of vinegar. The files will turn red at this point in the process. When they again resume their natural color, take them out and wash them in cold water; after which, oil with sweet oil, and wrap singly in brown wrapping paper, which will absorb the oil from the files.

The files will be clean by this mode, in about half an hour after they are put in. Large mill files can be cut by making more solution, and using a dish narrow and tall, so that the files can stand on the shank to let the scales fall away from them."

**DUNNING'S IMPROVED PIPE COUPLING.**

This invention, perspective and sectional views of which are represented in the annexed engravings, is claimed to provide a simple and cheap union or coupling for gas, steam, and water tubes, which may be applied even in long lengths of continuous straight pipe. It will also serve as a sliding or compensating joint to allow for contraction and expansion, and will, besides, prove useful when it is desirable to con-

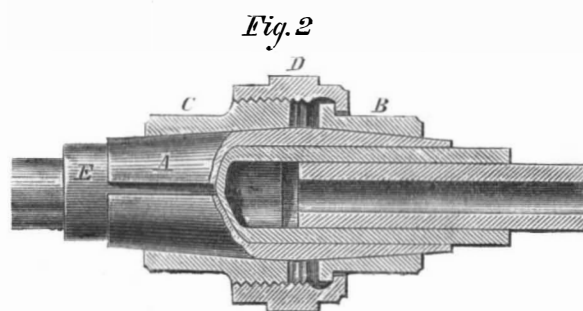
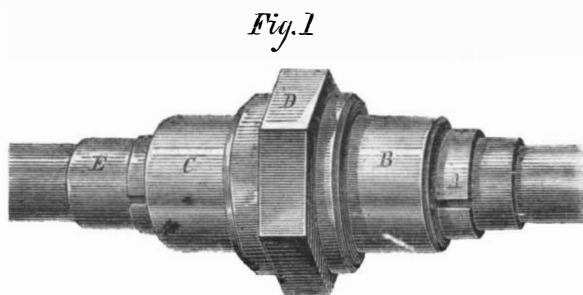

nect the ends of pipe in situations where threads cannot be conveniently cut thereon.

A is a conical sleeve, cut from end to end, as represented in Fig. 1, or, if desired, divided longitudinally into two separate portions. It is bored out somewhat larger toward the

center, so as to insure a bearing at the ends around the pipe when closed by the collars, B C, which are also bored to correspond with the conical shape of the sleeve. The collar, B, is flanged to receive the threaded coupling ring, D, to which it is swiveled, as indicated in the sectional view. Collar, C, is provided with a thread upon which the ring screws. The joint between the ends of the pipe is thoroughly packed by a section of rubber, E, or other suitable tubular packing.

To adjust the device, the extremities of the tube are thrown out of line, and the sleeve, A, containing the packing, E, and upon which the collars and ring have been placed, is applied to one end. The pipe is brought in line, and the rubber tube, with the other portions, is brought over the joint so as to overlap the two extremities equally. The ring, D, is then screwed up, drawing the two collars together upon the inclined surfaces of the conical sleeve, thereby compressing it firmly against the packing.

This coupling can be manufactured very cheaply of malleable iron, as all the parts can be cast of the necessary form and size for different pipes, and require no finishing or fitting except cutting the screw. It is claimed to cost no more than the ordinary union coupling, except the expense of the pliable hose for the packing. It makes a perfect slip joint as well as a good coupling, and will be found very useful for plumbers in repairing split pipe in places where a die cannot be used to cut threads on the pipes, or where the latter are close to the walls or among joists in buildings.

Patented September 30, 1873. For further particulars regarding sale of patents or rights under the same, address the inventor, Mr. Wm. B. Dunning, New York Central Iron Works, Geneva, N. Y.

**APPARATUS FOR FILTERING AND RECTIFYING SPIRITS.**

Mr. Christian W. Ackerman is the inventor of a novel device, herewith illustrated, for filtering and rectifying spirits, by means of which he claims to effect a saving of material from the usual loss by evaporation, a more perfect elimination of fusel oil, and also that by the apparatus a greater quantity of spirits can be treated in a given time than by the old process.

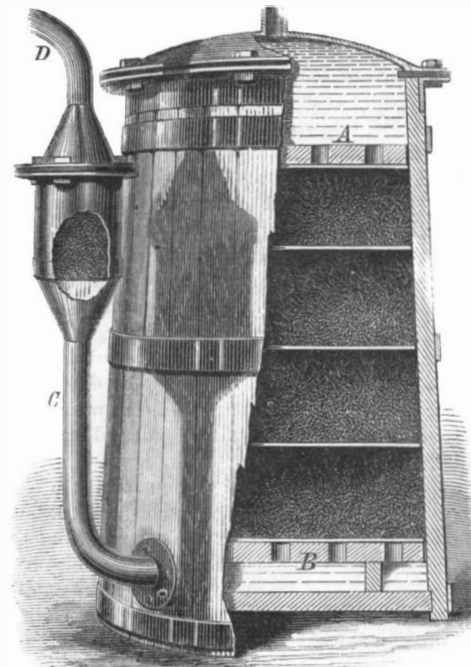

A receptacle of the form shown in the engraving is provided with two inner diaphragms, A and B. The lower one rests upon joists, and may be made in halves, to admit of easy removal when desired. Upon it is laid a circular piece of blanket of one thickness, then a stratum of powdered charcoal, equal to one fourth the distance between the diaphragms; then a double thickness of blanket, and so on for two more layers of coal and blanket, until the upper partition, A, is reached, beneath which a single piece of blanket is placed. The charger, which should be placed in the upper part of the building, communicates with the apparatus by the pipe at the top. The spirits therefrom enter with sufficient force to penetrate down through the diaphragms, which are perforated, and the layers of charcoal and blankets, leaving in the latter the fusel oil and other impurities. Finally, emerging beneath the false bottom formed by B, the liquor escapes by the pipe, C, and passes into another and smaller receptacle, in the interior of which are two wire gauze screens, the intermediate space being filled with cotton batting and blanket. Here the last rectification takes place, and the fluid, in a pure condition, is led away by the pipe, D.



**THE COCUYO.**

The cocuyo is a variety of firefly which abounds in Cuba and in some countries of South America, and which emits a light much more brilliant than that given off by the small insects common with us during the summer months. Its form and size are well delineated in the engraving herewith presented. At about the end of April it is found in damp and wooded places throughout Cuba, emerging from its hiding place at twilight, but rarely pursuing its nocturnal rambles for a greater length of time than two or three hours.

The brilliant radiance of the cocuyo is emitted from its ventral region, where there are three phosphorescent organs which the insect can expose and render luminous at will. It is believed that a substance accumulates slowly in the cells of these members, and is discharged voluntarily. As soon as this principle is set free it manifests itself by the production of light alone, without heat, and in a manner similar to that caused by the accidental decomposition of tissue, mucus, sugars, etc.

The insect lives in hollow trees and under dense shrubbery, subsisting on young leaves and similar vegetation. At about the end of July it disappears, though it may be kept until September or October. Occasionally importers of sugar from Havana, in this city, receive specimens of cocuyos from their correspondents, and we have ourselves obtained several in this way. They live for about a fortnight if supplied with brown sugar, though they prefer fresh sugar cane. By placing a few on a table, in a dark room, a curious and interesting effect is produced by the traveling points of light as the bugs run around the surface. Two or three cocuyos in a bottle will emit sufficient light at night to render a letter easily read or the face of a watch distinguished. They are often thus used by hunters, and Captain Mayne Reid, in one of his interesting juvenile works, makes use of this fact in describing how some surprise party of soldiers, in the Mexican war, managed to read important orders when they had no means of illumination, and, besides, could not have used the same for fear of discovery by the enemy. The cocuyo shows his light best while flying, but it can be forced to shine by dipping it in water for an instant. It is inoffensive to man, but a quarrelsome customer among its own species. When a number are confined fearful battles ensue, in which the claws form powerful weapons. Mutilation of the members is almost always the result, although the insect often lives for months after severe maiming.

The most recent application of the bug to useful purposes was its proposed utilization for lighting the interior of the car of the transatlantic balloon at night. The idea, it is needless to add, was never carried out.

**THE BRIGHTON AQUARIUM.**

The Brighton aquarium, while emulated by several buildings of a similar nature in different parts of England and the continent, still holds its own in being on a scale of magnitude hitherto unsurpassed, more than one of its tanks, in illustration of this, being of sufficient size to accommodate the evolutions of porpoises and other small cetacea. The works were commenced in the autumn of the year 1869, but owing to various interruptions the building was not formally thrown open to the public until August 1872.

The area occupied by the aquarium, says the eminent naturalist Mr. W. Saville Kent, in *Nature*, to which we are indebted for the engraving, averages 715 feet in length by 100 feet in width, running east and west along the shore line. The building internally is divided into two corridors separated from one another by a fernery and considerable interspace. The approach to the first or western corridor is gained through a spacious entrance hall supplied with reading tables, and containing, between the pillars which support the roof, portable receptacles of sea water for the display of small marine specimens that would be lost to sight in the larger tanks.

The tanks for ordinary exhibition commence on the left side of the western corridor, and follow in consecutive order round the two corridors, the last immediately facing No. 1. The smallest of these tanks measures 11 feet long by ten feet broad, and is capable of holding some 4,000 gallons of

water; while the largest, No. 6, in the western corridor, and the subject of the accompanying engraving, presents a total frontage, including the two angles, of 130 feet, with a greatest width of 30 feet, and contains no less than 110,000 gallons. Every gradation of size occurs between these two extremes, the depth of the water in all ranging from 5 to 6 feet. Supplementary to the foregoing, a series of half a dozen shallow octagonal table tanks occupies a portion of the interspace between the two corridors, these being especially adapted for the exhibition of animals such as starfish, anemones, and others seen to best advantage when viewed perpendicularly through the water. Flanking one side of this same inter-

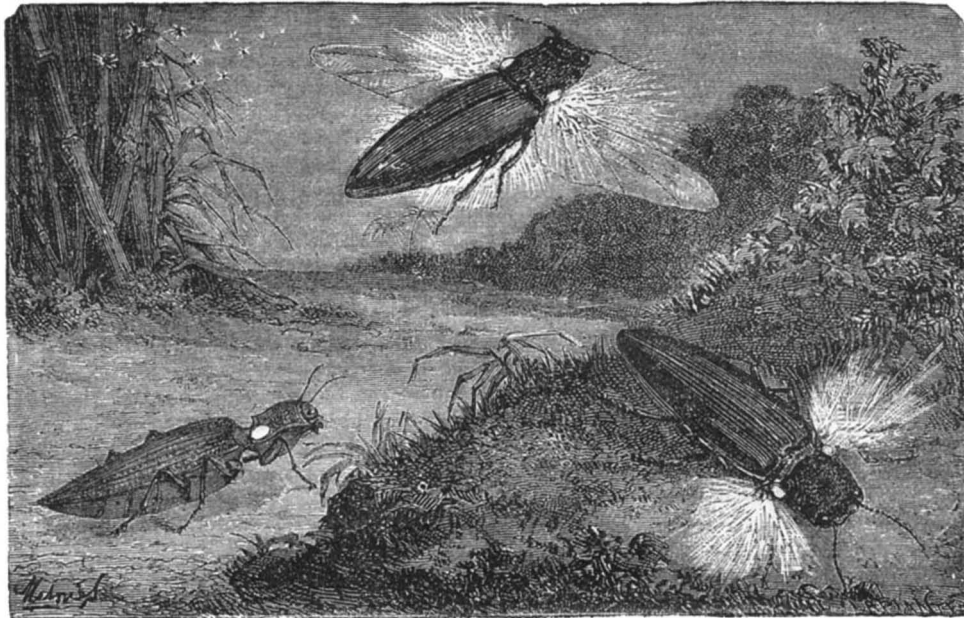

**THE COCUYO.**

space are several ponds fenced off for the reception of seals and other amphibious mammalia and larger reptilia, while at its further or eastern extremity artistic rock work runs to a light of 40 feet, thickly planted with choice ferns and suitable exotic plants, and broken in its course by a picturesque waterfall and stream. Tanks 12 to 17 in the eastern corridor, in addition to the stream and basin beneath the waterfall, are set apart for the exclusive exhibition of fresh water fish, the remaining tanks being devoted to marine species. The bulk of water thus utilized in the fresh and salt water tanks collectively amounts to 500,000 gallons, and in addition to this several smaller store tanks in the naturalists' room, adjoining the eastern corridor, afford accommodation for reserve stock, or for new arrivals before their display to public view.

The style of architecture dominant throughout the building is Italian and highly ornate, the arched roof of the corridors being groined and constructed of variegated bricks, supported on columns of Bath stone, polished serpentine marble, and Aberdeen granite; the capital of each column is elaborately carved in some appropriate marine device, while the floor in correspondence is laid out in encaustic tiles. The divisions constituting the fronts of the tanks are composed each of three sheets of plate glass, each plate having a thickness of one inch, and measuring six feet high by three feet wide, separated from one another and supported centrally by upright massive iron mullions; in the smallest tanks the front is represented by but one of these divisions, while that of the largest, No. 6, consists of as many as eleven. Among other conspicuous structural features of the aquarium demanding notice are the huge masses of rock entering into the composition of the tanks and fernery.

The system adopted at the Brighton aquarium for continually renewing the supply of oxygen, necessary for the well being of the animals, is by streams of compressed air, which are constantly forced into the tanks through vulcanite tubes carried to the bottom of the water, each tank being fitted with a greater or less number of these tubes according to its size.

**Ink in the Teapot.**

The adulteration of tea by the addition of iron filings has just been brought rather forcibly to public attention, by a communication to *Food, Air, and Water*, from the pen of Dr. Hassall. The iron is added, the doctor believes, not so much for increasing the weight of the tea as for giving a dark color

to the infusion; and since tea naturally contains a large amount of tannin, there are thus brought together the two chief ingredients of ink. Not content with asserting the fact, the doctor demonstrates it by extracting, from such adulterated tea, a bottle of ink and using it in the writing of his communication.

This is a common way of giving an appearance of strength to teas that have been already once steeped. Those who like inky tea can get it more cheaply by using a rusty tin teapot.

**Chinese Physiology.**

In some respects the Chinese are an intelligent people but they are not strong in science. Their physiology is especially whimsical. According to their notion, the chief organ of the human economy is the spleen. Its functions are manifold. It rubs against the stomach and grinds the food, it keeps up the proper degree of heat in the five *toang*; it moves the muscles and the lips, and thus regulates the opening of the mouth; furthermore, it directs our secret ideas so that they become known to us. The liver regulates the tendons and ornaments the nails of the hands and feet. The heart regulates the blood vessels, beautifies the complexion, and by its means we are enabled to open the ears and move the tongue. Of the circulation of the blood, the Chinese are profoundly ignorant. The kidneys govern the bones, beautify the hair of the head, and open the orifices of the two *yin*. The diaphragm, being spread out like a membrane beneath the heart, and joined all round to the ribs and spine, covers over the thick vapors so that the foul air cannot rise. The gall bladder is the seat of courage; hence the popular belief that whoever eats the gall of a brave man or beast will inherit the valor of its original possessor: a belief which frequently leads to a lively competition for the galls of remarkable animals.

Of the function of the brain, the Chinese have but a vague idea, still they think it has something to do with the intellect. In proof of this suspicion, they offer the case of a man of great renown for his learning, whose misfortune it was to fall from a horse with such violence as to break his skull. The physician who was called to treat the case hit upon the happy thought of supplying from the skull of a cow the portion of brain the wise man had lost. The operation was only a partial success, since the subject's eminent powers of mind remained in utter prostration, and from that time forward he was a very different man from what he had been. Whether his residual intelligence exhibited any bovine characteristics, our informant unhappily neglects to say.

Hereafter we expect to see this case given as additional evidence that the Chinese are the original discoverers of everything. It is certain that it greatly antedates the operation recently reported from Leipzig for the edification of rural editors: a case in which the brain of a good natured wine seller, dead of heart disease, was transplanted into the cranium of a soldier condemned to death for murder, with a corresponding transference of mental and moral traits. The Leipzig surgeon is plainly no better than a skillful imitator.

**The Persistence of a Name.**

A curious illustration of the living force of a name is to be seen in the title given to the Virgin Mary by the people of the Basque Provinces. In the most ancient records of Chinese history (the annals of the Bamboo Books, lately translated by Dr. Legge), the name *Ishtar* appears as one of the titles of the Queen of the Stars. Among the ancient Assyrians, *Ishtar* was their chief female divinity, the celestial virgin mother. In Solomon's time, the Syrian equivalent of the name was *Astarte*; and in II. Kings, the wise man himself is charged with having set up an altar to this fascinating goddess. In the Hebrew record, the spelling is *Ashtoreth*. By Milton the name is given as

"*Astoreth*, whom the Phœnicians called  
*Astarte*, Queen of Heaven."

Whether Phœnician voyagers left the name in Spain, or whether the Basques brought it with them in their original migration westward, it is impossible to say, nor does it matter. It is there in common use to this day, a living name with a history of at least five thousand years.

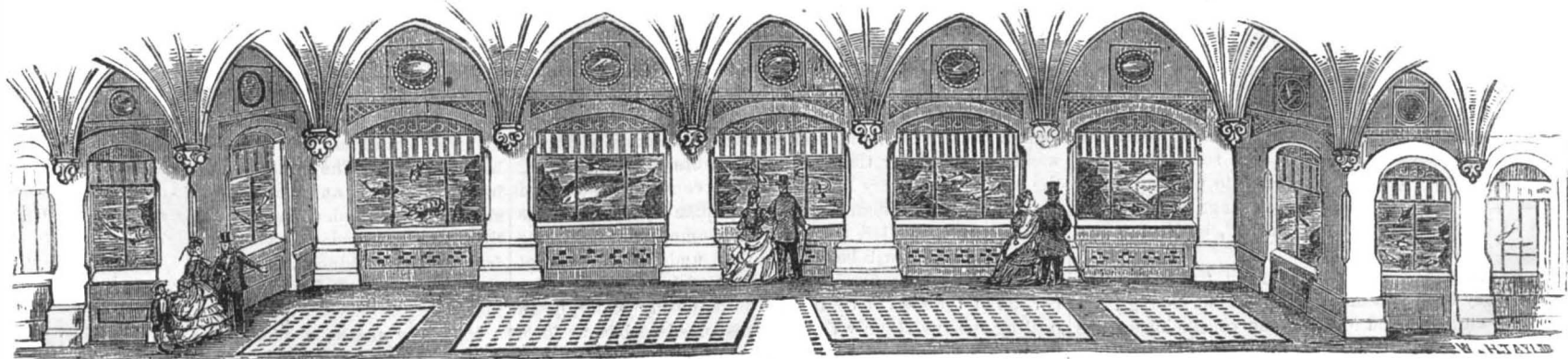

**FRONT VIEW OF ONE TANK OF THE BRIGHTON AQUARIUM.**

## THE GERM THEORY AND ITS RELATIONS TO HYGIENE.

BY PRESIDENT F. A. P. BARNARD, LL.D., OF COLUMBIA COLLEGE.

[PART II.]

## THE DOCTRINE OF BIOGENESIS.

This question was, however, not universally admitted to be settled. Dissenters made themselves heard from time to time, among them Gleichen, Othe, Müller, and Previranus, the latter of whom pointed out the significant fact that, while the species of infusorial animals found in infusions of the same kind were constantly the same, those which appeared in different infusions were not so. Early in the present century, the celebrated naturalist Lamarck ranged himself on the side of spontaneous generation. Oken took the same view, and subsequently Bory St. Vincent, J. Müller, Dujardin, Burdach, and Pineau, while on the opposite side appeared, among others, Schwann, Schultze, and Ehrenberg. The experiments of Schultze and Schwann were remarkable. They were undertaken for the purpose of testing the accuracy of those of Spallanzani. Since those experiments had been made, the importance of air, or of oxygen, one of its constituents, to the maintenance of animal life, had been discovered, and doubts had arisen whether, in those experiments, the air had not been rendered unfit for the support of life by the operations to which it had been subjected. In repeating the experiments, Schultze admitted to the flasks, after boiling the infusions, only such air as had been passed through concentrated sulphuric acid, and Schwann only such as had been conducted through red hot tubes. No animalcules made their appearance; and these results, reached as long ago as 1836 and 1837, were regarded by the great body of naturalists as finally settling the question.

## CONTROVERSIES OF THE SAVANTS.

The controversy, however, after resting for 20 years, was revived, and prosecuted with even more animation than before, by M. Pouchet, in the first instance, on the side of spontaneous generation, and M. Pasteur, on that of *biogenesis*, but more recently by many naturalists of distinction, among whom may be named Dr. Jeffries Wyman, of our own country, whose experimental researches tend rather to the support of the archeogenetic theory, and Professor Huxley, of London, whose opinion, given on a survey of the whole history of the controversy and expressed before the British Association in 1870, is very decidedly the other way. While the controversy was between M. Pasteur and M. Pouchet, there can be no doubt that, in the judgment of the world, the former had by far the best of the argument. His experiments, which were substantially repetitions of those of Needham and Spallanzani, but which were variously modified so as to render his demonstrations, in every possible way, cumulative, seemed to have disposed of the doctrine of spontaneous generation, effectually and forever. In multitudes of instances, infusions hermetically sealed while boiling remained for indefinite periods of time free from all traces of organic life, while portions of the same infusions, exposed side by side with these but open to the air, were speedily swarming with animalcules. He found that even an unsealed flask, of which the neck had been stopped during the boiling only with a plug of cotton, closely pressed together, continued to be equally free from these organisms so long as the stopper remained in its place. This last experiment presented a rather curious resemblance to that of Redi, with his gauze-covered jar; for the cotton forming the plug was found, on a microscopic examination, to contain the germs which its presence had prevented from entering the flask. M. Pasteur finally found—and this result was long supposed to have furnished an unanswerable reply to all the arguments of the advocates of *archeogenesis*—that flasks containing infusions treated by boiling as before required neither sealing nor stopping with cotton to prevent invasion of the contained liquids by these low forms of life: provided only that the necks of such flasks had been originally bent over, so as to direct their mouths downward. This result he had predicted as probable, holding, as he did, that the germs by which such infusions are reseeded, when the living embryos they may contain have been destroyed by heat, must necessarily subside into them from the air above.

The experiments of Wyman, Bastian, Cantoni, and others, more recent than those of Pasteur, have led to results singularly, and at present, we must say, unaccountably, at variance with his. Professor Wyman found that *bacteria* will make their appearance in infusions which had not only been boiled before being sealed up, but which, after being sealed, had been kept at a boiling heat for many hours. He found, moreover, that these same organisms perish when exposed to a heat not over 134° Fahrenheit. Bastian, in a very extended series of experiments, has pushed the heat in the tubes containing his infusions as high as 360° Fahrenheit, maintaining this high temperature, in some instances, not less than four hours; and has yet found that living forms do not fail subsequently to make their appearance in them. Such forms appear also, according to him, in solutions containing nothing of organic origin whatever, but which are composed entirely of certain salts of soda and ammonia; and he even affirms that in such solutions he has occasionally seen very remarkable fungi to present themselves with their full fructification, drawings of which he has given in his work, recently published, entitled "The Beginnings of Life."

It seems to me that no one can rise from the perusal of the extraordinary book just mentioned without feeling that, if it does not embrace and contain the conclusion of the whole matter, it is, at least for the present, unanswerable. It leaves us, nevertheless, still perplexed, perhaps more deeply perplexed than before; for it is impossible to under-

stand how the results reached by so many naturalists, all in the first rank of scientific investigators, all conscientiously laboring to elicit the truth of this great question, should be, after all, so singularly discordant. And another weighty consideration adds to this perplexity. It is the existence of a practical refutation of the conclusions of the class of experimenters to which Dr. Bastian belongs, which is presented under our eyes every day on the grandest scale in the operations of one of the most important branches of modern industry. I cannot state this consideration better than in the words of Huxley: "There must," remarks this distinguished physiologist, "be some error about these experiments, because they are performed on an enormous scale every day with quite contrary results. Meats, fruits, vegetables, the very materials of the most fermentable and putrescible infusions, are preserved to the extent, I suppose I may say, of thousands of tons every year, by a method which is a mere application of Spallanzani's experiment. The matters to be preserved are well boiled in a tin case provided with a small hole, and this hole is soldered up when all the air in the case has been replaced by steam. By this method they may be kept for years without putrefying, fermenting, or getting moldy." He argues—and the argument has a weight that must be felt—that there is no mode of explaining this universal and inevitable result but the exclusion of germs from these cans. And, in view of the marvelous discrepancy between the results on the small and the grand scale, placed side by side, one can hardly repress the suspicion that, if there be any such thing as spontaneous generation, it is a thing which occurs only under rare and extraordinary conditions, which conditions Dr. Bastian has unintentionally succeeded in establishing; while, as a matter of practical importance or daily interest, it is as if it were not.

## Zincing Iron.

The following is an excellent and cheap method for protecting iron articles exposed to the atmosphere, such as cramp irons for stone, etc., from rust: They are to be first cleansed by placing them in open wooden vessels, in water, containing three fourths to one per cent of common sulphuric acid, and allowed to remain in it until the surface appears clean or may be rendered so by scouring with a rag or wet sand. According to the amount of acid, this may require from 6 to 24 hours. Fresh acid must be added according to the extent of use and of the liquid; when this is saturated with sulphate of iron, it must be renewed. After removal from this bath, the articles are rinsed in fresh water, and scoured until they acquire a clean metallic surface, and then kept in water in which a little slaked lime has been stirred until the next operation. When thus freed from rust, they are to be coated with a thin film of zinc, while cold, by means of chloride of zinc, which may be made by filling a glazed earthen vessel, of about two thirds gallon capacity, three fourths full of muriatic acid, and adding zinc clippings until effervescence ceases. The liquid is then to be turned off from the undissolved zinc, and preserved in a glass vessel. For use, it is poured into a sheet zinc vessel, of suitable size and shape for the objects, and about 1:30 per cent of its weight of finely powdered sal ammoniac added. The articles are then immersed in it, a scum of fine bubbles forming on the surface in from one to two minutes, indicative of the completion of the operation. The articles are next drained, so that the excess may flow back into the vessel. The iron articles thus coated with a fine film of zinc are placed on clean sheet iron, heated from beneath, and perfectly dried; and then dipped piece by piece, by means of tongs, into very hot, though not glowing, molten zinc, for a short time, until they acquire the temperature of the zinc. They are then removed and beaten, to cause the excess of zinc to fall off.

## Water as Fuel.

A correspondent, Dr. A. A. Hayes, writes to say that recently two similar boilers were employed with widely different results as to consumption of fuel. On investigation it was found that, with the deficient boiler, "the workmen had been restricted to about twenty inches in draft of ash pit; the other furnace had a vault, permitting ashes and cinders to be retained for several days, while here the paved, clean floor formed the bottom of the ash pit. The fuel was remarkable for purity, and so compact as to be kindled with difficulty. On opening sight holes, the fire could be seen burning intensely; the radiant heat appeared to be absorbed; very slight flame only could be seen, but the rush of highly heated air was constant. After some time, observation showed that the ash pit was the only point on which suggestion could be excited, the matter of quality of fuel being in favor of the bad furnace. A casual observation had shown that the ashes of the good furnace were damp. The pavement of the room and the ashes were accordingly wetted on the ash pit floor. Immediately flame appeared at the door joints, and from cracks (from unequal expansion); the damper was hurriedly raised to allow the great volume of combustible matter to reach the chimney. The pressure gage partook of the new life, and soon an over abundance of steam was formed. After the adjustments were made for using the steam, and a very little water was constantly admitted to the ashes, more than the necessary quantity of steam was afforded by the boiler, while the consumption of fuel was not increased. It will be inferred that, under conditions not unusual, a great economical gain resulted from the use of a portion of the heat of contact in decomposing vapor, or in heating steam so highly that it transported carbon to form flame; the result was the conversion of an imperfect to an efficient apparatus, without added expense, in opposition to a theoretical law.

In numerous cases, continued through many years of observation, I have seen similar results follow the use of moist air in the combustion of dry anthracite; but this case is considered exceptional from the accuracy of the proofs afforded.

In reviewing these facts, it will be seen that a useless apparatus was rendered thoroughly efficient by forming flame from the otherwise ignited fuel. More importance than here appears belonged to the trials, for on the success thus obtained grew up a most extended application of steam, where every point connected with its use is registered with the precision of philosophical apparatus.

A doubt in regard to the consumption of fuel has probably been present in some minds. How could the fuel be consumed, and vivid combustion maintained, without a corresponding production of steam? The answer is founded, not on observation alone, but on experiments. In a cold, dry atmosphere, the best anthracites produce so intense a radiant heat that near by surfaces of iron become heated above the temperature of economical rapid evaporation. That kind of fuel, too, affording no flame in cold dry air, requires more than double the theoretical amount of oxygen for its combustion; and this volume of heated air and products of combustion is far less hot than flame, and is repelled by the parts of the boiler behind the space over the mass of glowing fuel, as less highly heated gases are always repelled by colder surfaces. In fact the steam-generating surface was so far reduced in area as to render it impossible for steam to be formed in time, and the heat was wasted.

My wish is to see more attention given to flame fuel, as contrasted with radiant heat fuel, not only as a facile and economical application, but as a check to the use of old devices which waste the fuel. A long step in this direction has been taken in heating gas retorts. Apart from great economy, the destruction and wear of apparatus is reduced, as they may be in steam production."

## California Wood Choppers.

It is in the logging camps that a stranger will be most interested on this coast; for there he will see and feel the big ness of the redwoods. A man in Humboldt county, says a writer in *Harper's Magazine*, got out of one tree lumber enough to make his house and barn, and to fence in two acres of ground. A schooner was filled with shingles made from a single tree. "One tree in Mendocino, whose remains were shown to me, made a mile of railroad ties. Trees fourteen feet in diameter have been frequently found and cut down; the saw logs are often split apart with wedges, because the entire mass is too large to float in the narrow and shallow streams, and I have even seen them blow a log apart with gunpowder. A tree four feet in diameter is called undersized in these woods; and so skillful are the wood choppers that they can make the largest giant of the forest fall just where they want it, or, as they say, they 'drive a stake with the tree.' The choppers do not stand on the ground, but on stages raised to such a height as to enable the ax to strike in where the tree attains its fair and regular thickness; for the redwood, like the sequoia, swells at the base, near the ground. These trees prefer steep hillsides, and grow in an extremely rough and broken country; and their great height makes it necessary to fell them carefully, lest they should, falling with such an enormous weight, break to pieces. This constantly happens in spite of every precaution, and there is little doubt that, in these forests and at the mills two feet of wood are wasted for every foot of lumber sent to market. To mark the direction line on which the tree is to fall, the chopper usually drives a stake into the ground 100 or 150 feet from the base of the tree, and it is actually common to make the tree fall upon this stake, so straight do these redwoods stand, and so accurate is the skill of the cutters. To fell a tree eight feet in diameter is counted a day's work for a man."

## An Inexhaustible Inkstand.

We have received from Messrs. Root, Anthony, & Co., of 62 Liberty street in this city, an inkstand, for the use of which the directions are: Put in a little cold water, let it stand for 3 or 4 hours, and the ink will be ready for use. We suspect that the coloring matter is supplied by some means analogous to Professor Bottger's invention for portable ink, already described in our columns. Our readers' grandchildren will be better able to speak to the permanency of the supply of ink; in the meantime, we can say that, after a trial, we find the inkstand to be filled with black ink of an excellent quality.

## Sexadigitism.

A valued correspondent, W. T. R., writes as follows: "Recently, I fell in company with a gentleman with a peculiarity in one of his hands. I requested permission to make an examination, when, to my surprise, I found that he had an extra finger hinged on to the metacarpal bone, just back of the little finger and extending sideways from the palm of the hand; it shut up in the fist, but at right angles to the other fingers. Four of his children have similar developments on each hand, while a fifth child has six fingers on but one hand. The father and the children have each six toes on each foot, and a nephew who accompanied them was similarly endowed. Many of their ancestors and some of their relatives had or have sexadigital limbs. It appears, from evidence adduced, that these peculiarities were derived from a family in which they have existed from time immemorial.

If by any means a family inheriting such peculiarities should become isolated, the consequence would probably be a sexadigital race, which, according to the common rules of classification, would constitute a new species."



**How Tin Plate is Made.**

A paper recently read before the Franklin Institute of Philadelphia, by Mr. T. S. Speakman, representative of the Institute at the Vienna Exposition, gives the following interesting details of the manufacture of tin plate as carried on in Wales:

In the opinion of Mr. Henry I. Madge, tin plate manufacturer, of Swansea, in Wales, from whom I received the following information, the manufacturer prefers making his own iron to purchasing it, because he can thereby insure a more equable quality; he therefore buys suitable pig iron.

For common coke tin plates, the "iron bars" are made from puddled iron. The puddled ball is sometimes squeezed and sometimes hammered; much depends on the care of the puddler to so bring forward his ball that all its parts shall be equally decarbonized, when the fracture will be of a uniform, dull gray color, without crude admixtures of bright crystals. The unreduced crystals produce "wasters" of the iron plates; and if any such escape the notice of the mill manager, the wasters are thrown aside again after being covered with tin. If they escape the eye of the "assorter," the tin plate worker will find them fracture across the angles or bends of the sheets in working them up. The puddled ball, produced under the best conditions, is then taken to the "shingler," who submits it to the squeezer or hammer, sometimes both. This operation should be carefully executed. As the puddled ball is rugged and full of cinder, the cinder has to be squeezed out by this operation, and at the same time the roughness must be so managed as to be welded into a solid compact mass, which cannot be so well done in after operations. Some say it cannot be done afterwards, as the whole mass can never again be brought up to a thorough welding heat throughout, unless at the expense of much waste and loss. The bloom from the "shingler" is at once passed through the rolls, or roughed down to No. 1 bar. Some prefer letting the blooms lie exposed to the action of the elements for a time, and others think it of no importance. The bar, while hot, is cut into lengths and piled, five pieces being put and heated together in the "balling" or reheating furnace. When the faces are brought up to a welding heat, and the whole mass softened, it is again taken to the hammer, some rolling at once, others returning the bloom into the furnace to again bring up the heat. It is then rolled out into the finished bar, of suitable size and thickness for the kind of plates required.

Some manufacturers have made very good iron from the puddled ball direct, saving in wasters and improving the quality; but as the labor and number of hands were reduced by this mode, the men struck against it, and spoiled their work if not well looked after. This kind of iron was homogeneous and not fibrous, as the iron "piled" and brought through the reheating furnace is. The "shingler" must be very careful to form a second bloom under the hammer, and the bloom should be upset once or twice, so as to secure a welding of all the rough edges. If, after the shingling, the bloom has lost too much heat, it should be reheated. Care and expedition will remedy that necessity, and the reheating furnace dispensed with altogether. The saving is much in cost and waste; but the trouble with the workmen was great. Some also produced very excellent iron from the puddling furnace by adding to the charge about 60 lbs. of scrap or shearings, the trimmings of the plates when cut to size. The 60 lbs. of shearings were thrown into a bath of saturated solution of nitrate of soda, but added to the charge during the "boiling." The advantages gained were: the scrap iron improved the charge in proportion it bore to the whole mass; it was melted down quickly without waste, as the smelting took place under the surface. The weight of solid cold iron would take it to the bottom of the charge, carbon would be eliminated by fusion with the nitrate, and thereby improve the quality of the charge again. The ball was treated in the same way as ordinary puddled balls afterwards. The iron was tough as charcoal iron, with the characteristics of puddled iron, arising from crudities; for crystals unreduced were not exterminated, but greatly lessened. A careful puddler can at all times prevent these crude lumps to a very great extent. Another saving arising out of the process was that the scrap "shearing," formerly put into a furnace and reduced to a welding state, hammered out and rolled, gave only a return of 13 per cent to the tun, whereas the other returned the full weight of the shearings. However, difficulties with the union men prevented them from pursuing this mode of manufacture.

The bars are cut up into the required sizes, brought to a cherry red heat in a reverberatory furnace, rolled out to a certain length by gage, "doubled," and returned to the furnace, rerolled, again doubled, heated and reheated. The several foldings of the sheets adhere slightly.

After the sheets are cut down to size for tinning, they are separated from each other by what is called opening; during the process of opening, "stickers" and imperfect plates are thrown out, and the passed sheets then go into the "pickling room." There they are put into a hot pickle of dilute sulphuric acid, to be cleansed from oxydized and silicious matters, and undergo another rough examination in the "scouring process;" that is, any plate not cleansed is rubbed with sand in water. Defective sheets are again thrown out, and the sheets or plates are now passed into the annealing room.

The annealing furnace is a large reverberatory furnace, capable of holding several annealing pots. The pot is composed of a stand, of sufficient size to take the sheets, with a raised rim. Several hundred sheets are piled on the stand, and a square, box-shaped cast pot completes the pot. This is inverted over the sheets, and the space between the rim of the stand and the rim of the inverted pot is filled with

oxide of iron, to lute it down and exclude the air. The pots are then put into the furnace until it is full, and the whole brought up to a cherry red heat, or a little beyond. About eight hours are necessary for its perfect saturation by the heat. When removed from the furnace, they are slowly cooled in a place free from draft, and then the pots are opened. The plates never lie perfectly flat, and should be of a dark straw color at the edges. If the air should get in in small quantities, a deep blue color will cover the sheets more or less. The plates adhere slightly, are again separated, and ready for the second pickling room. The plates are then submitted to a hot but more dilute pickle of sulphuric acid, and again chemically cleansed; taken from the acid bath, they are well washed in running water, and kept in clean water until the tinman is ready for them.

The tinman takes the plates from the water bath (where they lie some hours) and plunges them wet into a bath of hot palm oil, called the "grease pot." When they have acquired the temperature of the grease pot, they are removed with tongs and quickly submerged in a bath of tin. The oil mixed with the water from the plates floats at the top, forming a flux which covers the melted tin and prevents oxidation. With the tongs, the sheets or plates are continually kept moving and separated, to insure the tin getting between all of the sheets. When the bath has recovered its heat, which it generally does in about half an hour, the tinman examines the charge, and if he finds that perfect amalgamation has taken place between the two metals, he removes them with a tongs to the next bath, which is kept at a low temperature.

The temperature, raised by the change from the "tin pot," is again allowed to cool down to a few degrees over the melting point of the tin, when the plates are taken in lots of a dozen or two at a time, and laid on an iron slab, which is at the side or head of the pot. The waste metal and grease run back into the pot, the slab being inclined. The workman then takes up sheet by sheet with the tongs, and dips each into another bath of fine metal, kept at a heat little over melting point, immediately withdraws it, and places it in a rack immersed in a large pot of melted palm oil kept at the proper temperature, where they are allowed to remain a certain time. The sheets are then slowly lifted out of the grease by a boy, who separates them into proper lots by counting carefully, regulating the intervals of time between them. The grease recoils from the top plate; and as little is left on the sheets, they are again placed in a rack in the open air to cool; when cool, a lad takes each sheet in a tongs, and dips the lower edge into a small bath of melted tin so regulated that the sheet can only enter to about the eighth of an inch. It is kept long enough to melt off the drops of metal which adhere to the lower edge; and when lifted, the sheet is struck to throw off the superfluous metal from the edge. The plates are again put into a rack, and taken while warm to a bin of bran, where each sheet is thrust into and under the bran, to get rid of the grease which adheres. It is then passed on to a second and third hand, when the grease is pretty well behind in the last bin, which is kept filled with new bran. The sheets are turned out covered with flour dust and bran, and dusted off with cotton shaggy cloth.

The next process is in the sorting room. Here the finished sheets are laid on tables, and each sheet undergoes an examination by the sorter, who throws out those shearings which are defective in the iron or trimmings. The latter are reheated to regain the tin; the imperfect sheets are sold as "wasters" at a less price; the sheets are counted, and the box of 100 lbs. weight is composed of 225 sheets of 14 inches by 10 inches, for home use or for exportation.

**What an Englishman Thinks of American Railway Traveling.**

Mr. Robert W. Edis, an intelligent English architect, is now communicating to the *Building News*, London, a series of interesting letters from this country, giving an account of his experience in traveling from New York to the West. In one of these recent letters he draws the following comparisons between the railway facilities of the old and new worlds:

"No one who has not been in America can thoroughly understand or appreciate the comfort and luxury of these palace cars, in which, whether by night or day, the traveler may journey for days together without the misery and cramped-up feeling in our own railway cars; a comfortable seat by day, with plenty of room for legs and knees, and a luxurious bed by night, entirely shut off from your neighbor, with good attendance, lavatories, and other conveniences, all tend to make traveling in the States, where great distances have to be got over frequently and rapidly, comfortable, not to say as luxurious and safe as human ingenuity can make it. It may not be out of place to mention that no expense is spared in the construction or fitting up of these cars, the cost of which often varies from \$15,000 to \$25,000, and that, built as they are in the most strong and substantial manner, and attached invariably to the end of the train, the minimum amount of risk is thereby incurred in case of "telescoping" or "colliding" in the course of a long journey. Not only in this comfort of traveling, but in the universally adopted system of baggage checking, by which endless trouble and annoyance is saved to travelers, may we in England learn a useful lesson; but while railway directors here are content to allow their servants to labor ten or twelve hours at a stretch *per diem*, on work requiring not only constant hard bodily labor, but continual mental anxiety in "blocking," "signaling," and "switching," etc., we can hardly expect to be free from those pleasant but exciting incidents in railway traveling which too often terminate fatally, or, as frequently is the case, maim and wound, either

bodily or mentally, for life; for which some poor, wretched, overworked signalman or under servant is sought to be made responsible, while the real workers of the evil, the directors and heads of departments, seem to value the safety and comfort of the public as little as they recognize the mental and bodily labor of their servants, and for which they pay the minimum amount of wages. I can imagine the horror and dismay with which an English railway director would look upon the comfortable seats, the luxurious fitting up, the pleasant heating apparatus, the general good system of lighting, the lavatories, etc., and the iced water tanks attached to the palace cars of America and Canada, not to mention the comfortable beds and night accommodation which make traveling in the States almost a pleasure, instead of a nuisance and a trouble, as it invariably is in this country; or the dismay with which they would accept or adopt the aids to safety in case of accident, in the shape of Miller's platforms, Westinghouse brakes, and get-at-able cord communications. This is a digression, brought about by a comparison of recent traveling in the old and new countries, for which I pray the pardon of my readers."

**The Horse Bit.**

The question of the bit, and of the hand that rules the bit, underlies the consideration of the whole subject of man's dominion over the horse. The intelligence of mankind has hitherto invented but two principal forms of bit; the snaffle, the simple piece of iron which lies across the mouth, subject to endless modifications, such as being twisted, jointed, and so forth; and the curb bit, a more powerful implement, which has likewise undergone innumerable variations. The curb bit is an adaptation of the principle of the lever, and the lengthening of the check piece allows a very powerful pressure to be exercised upon the jaw of the horse. The snaffle is, so to say, a natural bit, and the curb an artificial one. The snaffle was used by our ancestors and by the ancient Greeks; the curb is an Asiatic invention, and was probably brought into Europe with the Moors. In the famous mosaic found at Pompeii, representing, as is supposed, a battle between the Greeks and Persians, and which, at any rate, is the picture of a battle between Europeans and Asiatics, the Eastern horsemen ride with curbs, and the Europeans with snaffles. The difference in the bit modifies the whole style of riding; and as there are two sorts of bits, so are there two quite different styles or schools of horsemanship, which may be called the Eastern and Western styles. The type of the Eastern is best seen in the modern Bedouin Arab, with his short stirrups, peaked saddle, and severe bit; and the Western type in its simplest form is beautifully exemplified in the Elgin marbles, where naked men bestride bare-backed horses. To ride after this fashion is an athletic exercise; the strength of the man is set against the strength of the horse, with little adventitious aid. The rider restrains the horse's impetuosity by the sheer force of his arm, and he maintains a seat on his back by exercising the muscles of his legs. It is the equitation of athletes and of heroes; but it is clear that the balanced seat of the Arab, and the more complete command over his horse which follows from the greater security of his seat, would make him infinitely more formidable in war than the European, in spite of the superior size and strength of the latter. History teaches us how the cavalry of the Saracens—small men on small horses—rode down the Christian horsemen till they learned to ride with the bits, and saddles, and lances of the Moslem cavalry. The invention of the curb bit necessitated the stirrup, for a man sitting upon a bare-backed horse is forced to bear, at times, more or less heavily upon the bridle; and if, so riding, he were using a curb bit, and he were to lean any part of his body upon it, his horse would stop, or would rear, or would flinch. The ancient Greeks and Romans are believed not to have known the use of stirrups. They are, indeed, said not to have been discovered till the fifth century of our era. This, if it is true, would only apply to Europe. In the East they were used many centuries before. The earliest representation of one I know is in the above mentioned mosaic, where the horse of a dismounted trooper in Oriental costume is drawn with clearly indicated stirrups; the Greek horsemen in the mosaic are without them.—*New Quarterly Magazine*.

**A PRACTICAL SYSTEM FOR THE SALE OF PATENTS.**

We have recently received from Messrs. S. S. Mann & Co., corner of Linden avenue and Hoffman street, Baltimore, Md., a neatly printed manual and a number of sample blanks, the collection being explanatory of a system which the above firm have devised for the use of inventors desirous of disposing of their patents or rights under the same. The book of instructions comprises practical and excellent advice relating to the proceedings incident to selling patents or of making arrangements for the manufacture of articles on royalty. With this work are supplied full sized blanks, handsomely printed, consisting of forms for grants of rights, powers of attorney, etc., with which are furnished detailed printed explanations.

From examination of the method we believe it will be an acquisition of much value to inventors. We are informed that the system has been adopted by many patentees, all of whom have expressed complete satisfaction.

**CEMENT FOR WOOD VESSELS.**—A mixture of lime clay and oxide of iron, separately calcined and reduced to fine powder, then intimately mixed, kept in a close vessel, and mixed with the requisite quantity of water when used. This will render a vessel watertight if the ingredients are good.







B. says: I have lots of boiled bones and animal matter, and I think of employing them in making fertilizers. How can I make superphosphates, bone dust and bone manure? What other materials shall I mix with the bones, and what kind of a mill is used for crushing and grinding the stuff? Answer: Your best plan is to grind the bones and mix the bone dust with ashes or ordinary manure. This forms an excellent fertilizer. There are many mills in the market for grinding and crushing, and an advertisement for the mill you need would probably bring you the information.

W. P. B. says, in reply to a correspondent who complains of a gummy substance which exudes from his boots: It is not the wax from the thread, but comes from poor oil used in finishing the leather. Cod oil (the proper article) was so scarce a few years since that other oils, particularly menhaden or porgy, were used instead or and to adulterate it, so that it became almost impossible to get a true cod oil. I have seen hundreds of sides of leather stuck together in the roll so as to need two men to separate them. It has now become possible to get good oil, and there is little danger of gum on leather from any responsible tanner.

F. N. says, in reply to G. W. C., that the largest wheeled locomotive would reach the foot of the hill first, for she would have the advantage of the other both in gravity and friction.

L. S. F. says: Let S. M. S. kill his roaches by making a mixture of Paris green and flour in equal parts. Then pour enough water upon the floor, in the place which the roach frequents, to form a little puddle, and form a circle of the mixture around it. They will run over it to drink, and thus deaden their legs with the poison. In making their toilets, they lick their legs, and so eat the poison, which soon despatches them.

MINERALS, ETC.—Specimens have been received from the following correspondents, and examined with the results stated:

M. W. H.—Your specimens are particles of galena disseminated in sand.

W. A. D.—Blende, sulphide of zinc.

E. A. W.—Grains of quartz.

G. O. H.—It is an alloy of copper, but a chemical analysis will be necessary to determine the constituents.

L. S.—No. 1 is bituminous shale. No. 2 resembles oxide of iron.

R. E.—Galena (sulphide of lead) in limestone.

R. C.—Your mineral is crystallized sulphate of lime, known to mineralogists as selenite.

P. S.—Nos. 1 and 2 are iron pyrites. No. 3 is galena. No. 4 resembles oxide of iron in quartz.

C. H. C.—Carbonate of lime. Dilute hydrochloric acid will rapidly dissolve it, and will not materially injure iron pipes, if not kept too long in contact with the metal.

W. K.—Barytes, sulphate of baryta.

J. H. S.—Sandstone.

R. F. S.—1. Blende. 2. Blende with barytes. 3 and 4. Blende (sulphide of zinc). 5. Arragonite, a form of carbonate of lime. 6. Quartz and oxide of iron. Read Dana's "Mineralogy."

W. C. B. asks: What is the best varnish to use on a water color drawing, that will not blot or crack off afterwards?—T. F. asks: If the sum of two squares be given, can science determine the two particular squares which compose the sum?—F. C. says: We put up fruit in airtight jars, and never put a jar away until we had taken off the iron clamp and found that the jars were tight enough to be lifted up by the cover. Notwithstanding this, three of the jars burst. As they were airtight, how could they ferment?—F. A. asks for a remedy for a fever sore, which breaks out on the slightest exertion.—J. O. H. asks for a cheap indelible coloring matter, or paint, which could be used with a brush in marking the horns of cattle.—H. B. asks: How can I put the finish on brass as it is in watch movements?—T. B. J. asks: What is the composition of the ink used on handstamps and for saturating ribbon for ribbon stamps?—J. E. E. says: In a suit now in the San Francisco courts, against a sea captain for alleged cruelty to a seaman, it is shown by the witnesses that it is a common practice on shipboard to hang sailors up by the wrists as a punishment. Will some one scientifically explain the physical effect of this punishment upon the system?—J. A. McK. asks: What two metals, gases, or other substances are the most subject to expansion and contraction by heat and cold?—S. S. R. asks: Can you inform me what variation occurs in the time of sunrise and sunset on the same day of the same month, in the same place, but in different years?

COMMUNICATIONS RECEIVED.

The Editor of the SCIENTIFIC AMERICAN acknowledges, with much pleasure, the receipt of original papers and contributions upon the following subjects:

- On the Coal Tar Interest. By H. C. F.
On Treatment of Cancer. By G. W. B.
On a Cheap Fertilizer. By G. W. B.
On Mysterious Boiler Explosions, etc. By C. B.
On Fireless Engines. By I. P.
On the Science of Iron and Steel. By C. C. Jr.

Also enquiries from the following: C. R. C.—W. L. A.—H. H.—J. T. S.—J. H. G.—P. L.—B. W. W.—S. B. H.—F. B.—J. F.—E. C. M.—J. M. S. Jr.—E. N.

Correspondents in different parts of the country ask: Who makes a carpet stretcher with a magnet in it to hold the tacks? Who makes coal-cutting machinery? Who makes pea shellers? Who makes the best steam washing machinery? Who makes plaster fuses? Who makes transplanters? Who sells horse power potato diggers? Who sells machines for pearling barley? Who makes small lithographic presses for amateur use? Who makes small steam engines for running jig saws, etc.? Where can apparatus for burning petroleum be obtained? Who makes diamond drills? Makers of the above articles will probably promote their interests by advertising, in reply, in the SCIENTIFIC AMERICAN.

Correspondents who write to ask the address of certain manufacturers, or where specified articles are to be had, also those having goods for sale, or who want to find partners, should send with their communications an amount sufficient to cover the cost of publication under the head of "Business and Personal" which is specially devoted to such enquiries.

[OFFICIAL.]

Index of Inventions FOR WHICH Letters Patent of the United States WERE GRANTED FOR THE WEEK ENDING

November 11, 1873,

AND EACH BEARING THAT DATE.

(Those marked (r) are reissued patents.)

Table listing various inventions such as 'Animal substances, preserving, C. Alden (r)', 'Auger, earth, W. Cole', 'Bale tie, cotton, A. G. Buford', etc., with corresponding patent numbers.

Table listing various inventions such as 'Life preserving cape, G. & C. Palmer', 'Loom temple, N. Chapman', 'Mattress, wire, D. J. Powers', etc., with corresponding patent numbers.

APPLICATIONS FOR EXTENSIONS.

Applications have been duly filed and are now pending for the extension of the following Letters Patent. Hearings upon the respective applications are appointed for the days hereinafter mentioned:

EXTENSIONS GRANTED.

Table listing granted extensions such as '26,000. RN PLANTER.—E. C. Allen', '26,028.—MANUFACTURE OF GAS.—L. D. Gale', etc.

DESIGNS PATENTED.

Table listing patented designs such as '6,987.—DRINKING GLASSES, ETC.—T. G. Cook, Phila., Pa.', '6,988.—COLLARETTE.—A. S. Ellison, New York city', etc.

TRADE MARKS REGISTERED.

Table listing registered trade marks such as '1,522.—GOLD PENS.—C. M. Fisher, New York city', '1,523.—CLOTHES WRINGER.—Haley & Co., Boston, Mass.', etc.

SCHEDULE OF PATENT FEES.

Table listing patent fees such as 'On each Caveat.....\$10', 'On each Trade Mark.....\$25', 'On filing each application for a Patent (17 years).....\$15', etc.

Table listing costs for patent services: 'On granting the Extension.....\$50', 'On filing a Disclaimer.....\$10', 'On an application for Design (3 1/2 years).....\$10', etc.

VALUE OF PATENTS, And How to Obtain Them.

Practical Hints to Inventors.

PROBABLY no investment of a small sum of money brings a greater return than the expense incurred in obtaining a patent, even when the invention is but a small one. Large inventions are found to pay correspondingly well. The names of Blanchard, Morse, Bigelow, Colt, Ericsson, Howe, McCormick, Hoe and others, who have amassed immense fortunes from their inventions, are well known. And there are thousands of others who have realized large sums from their patents.

More than FIFTY THOUSAND inventors have availed themselves of the services of MUNN & Co. during the TWENTY-SIX years they have acted as solicitors and Publishers of the SCIENTIFIC AMERICAN. They stand at the head in this class of business; and their large corps of assistants, mostly selected from the ranks of the Patent Office: men capable of rendering the best service to the inventor, from the experience practically obtained while examiners in the Patent Office: enables MUNN & Co. to do everything appertaining to patents BETTER and CHEAPER than any other reliable agency.

HOW TO OBTAIN PATENTS This is the closing inquiry in nearly every

letter, describing some invention which comes to this office. A positive answer can only be had by presenting a complete application for a patent to the Commissioner of Patents. An application consists of a Model, Drawings, Petition, Oath, and full Specification. Various official rules and formalities must also be observed. The efforts of the inventor to do all this business himself are generally without success. After great perplexity and delay, he is usually glad to seek the aid of persons experienced in patent business, and have all the work done over again. The best plan is to solicit proper advice at the beginning. If the parties consulted are honorable men, the inventor may safely confide his ideas to them; they will advise whether the improvement is probably patentable, and will give him all the directions needful to protect his rights.

How Can I Best Secure My Invention?

This is an inquiry which one inventor naturally asks another, who has had some experience in obtaining patents. His answer generally is as follows, and correct: Construct a neat model, not over a foot in any dimension—smaller if possible—and send by express, prepaid, addressed to MUNN & Co., 37 Park Row, together with a description of its operation and merits. On receipt thereof, they will examine the invention carefully, and advise you as to its patentability, free of charge. Or, if you have not time, or the means at hand, to construct a model, make as good a pen and ink sketch of the improvement as possible and send by mail. An answer as to the prospect of a patent will be received, usually, by return of mail. It is sometimes best to have a search made at the Patent Office; such a measure often saves the cost of an application for a patent.

Preliminary Examination.

In order to have such search, make out a written description of the invention, in your own words, and a pencil, or pen and ink, sketch. Send these, with the fee of \$5, by mail, addressed to MUNN & Co., 37 Park Row, and in due time you will receive an acknowledgment thereof, followed by a written report in regard to the patentability of your improvement. This special search is made with great care, among the models and patents at Washington, to ascertain whether the improvement presented is patentable.

To Make an Application for a Patent.

The applicant for a patent should furnish a model of his invention if susceptible of one, although sometimes it may be dispensed with; or, if the invention be a chemical production, he must furnish samples of the ingredients of which his composition consists. These should be securely packed, the inventor's name marked on them, and sent by express, prepaid. Small models, from a distance, can often be sent cheaper by mail. The safest way to remit money is by a draft, or postal order, on New York, payable to the order of MUNN & Co. Persons who live in remote parts of the country can usually purchase drafts from their merchants on their New York correspondents.

Foreign Patents.

The population of Great Britain is 31,000,000; of France, 37,000,000; Belgium, 5,000,000; Austria, 36,000,000; Prussia, 40,000,000, and Russia, 70,000,000. Patents may be secured by American citizens in all of these countries. Now is the time, when business is dull at home, to take advantage of these immense foreign fields. Mechanical improvements of all kinds are always in demand in Europe. There will never be a better time than the present to take patents abroad. We have reliable business connections with the principal capitals of Europe. A large share of all the patents secured in foreign countries by Americans are obtained through our Agency. Address MUNN & Co., 37 Park Row, New York. Circulars with full information on foreign patents, furnished free.

Caveats.

Persons desiring to file a caveat can have the papers prepared in the shortest time, by sending a sketch and description of the invention. The Government fee for a caveat is \$10. A pamphlet of advice regarding applications for patents and caveats is furnished gratis, on application by mail. Address MUNN & Co. 37 Park Row, New York.

Value of Extended Patents.

Did patentees realize the fact that their inventions are likely to be more productive of profit during the seven years of extension than the first full term for which their patents were granted, we think more would avail themselves of the extension privilege. Patents granted prior to 1861 may be extended for seven years, for the benefit of the inventor, or of his heirs in case of the decease of former, by due application to the Patent Office, ninety days before the termination of the patent. The extended time inures to the benefit of the inventor, the assignees under the first term having no rights under the extension except by special agreement. The Government fee for





Advertisements.

Advertisements will be admitted on this page at the rate of \$1.00 per line for each insertion.

The value of the SCIENTIFIC AMERICAN as an advertising medium cannot be over-estimated.

American Saw Co. NO. 1 FERRY ST., NEW YORK. Movable-Toothed Circular Saws. Eccentric Geared Power Presses.

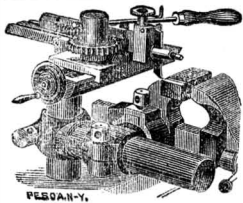

Universal Hand Planing Machine. A labor-saving invention, attached to any vise, or to work itself, indispensable to all metal-working mechanics.

ROGERS' TANNATE OF SODA, against Incrustation in boilers; generally approved by Scientists and Engineers.



CHAMPION SPRING MATTRESS—The latest and best improvement. Do you want a healthy and comfortable bed?

INDEPENDENT BOILER FEEDERS SEND FOR ILLUSTRATED CATALOGUE COPE & MAXWELL MFG. CO. HAMILTON, OHIO.

SCIENCE RECORD A Yearly Compendium of Scientific Progress and Discovery. 600 pages, octavo. Price \$2.50.



THIS NEW AND splendid annual book presents in brief form the most interesting Facts and Discoveries in the various Arts and Sciences that have transpired during the preceding year of this exhibiting in one view the General Progress of the World in the following Departments:

12.—GEOLOGY AND MINERALOGY. 13.—ASTRONOMY. 14.—BIOGRAPHY. Every person who desires to be well informed concerning the Progress of the Arts and Sciences should have a copy of SCIENCE RECORD.

FREEMAN & BURR, CLOTHING WAREHOUSES, 138 & 140 Fulton St., N. Y.

FREEMAN & BURR'S IMMENSE STOCK embraces all the popular Styles and Fabrics in SUITS, OVERCOATS, and CLOTHING of every description for all classes and occasions.

ORDERS by LETTER—FREEMAN & BURR'S new system for Self-Measure, of which thousands avail themselves, enables parties in all parts of the country to order direct from them, with the certainty of receiving the most PERFECT FIT attainable.

TRY THE VICTOR DRILL CHUCK.—Warranted to hold with a clasp of the hand. Triumphant at Vienna. HUBBARD & CURTISS MANUFACTURING CO., Address Middletown, Conn.

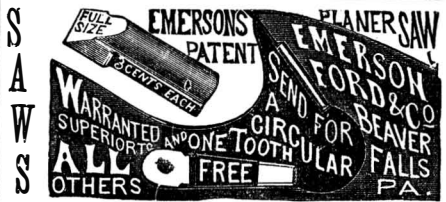

WIRE ROPE. JOHN A. ROEBLING'S SONS MANUFACTURERS, TRENTON, N. J. FOR Inclined Planes, Standing Ship Rigging.

BUILDERS Send for Catalogue. A. J. BICKNELL & CO., 27 Warren St., N. Y.

ALUMINOUS AND ORNAMENTAL BUILDING PAPER

STATIONARY AND PORTABLE STEAM ENGINES. Babcock & Wilcox Patent Safety Boilers, LEFFEL'S DOUBLE TURBINE WATER WHEEL, SHAFTING, PULLEYS, HANGERS AND GEARING. POOLE & HUNT, BALTIMORE.

NOYE'S MILL FURNISHING WORKS are the largest in the United States. They make Burr Millstones, Portable Mills, Smut Machines, Packers, Mill Picks, Water Wheels, Pulleys and Gearing, specially adapted to flour mills.

IRON PLANERS. ENGINE LATHES, DRILLS, &c. Send for Price List. NEW HAVEN MANUFACTURING CO., New Haven, Conn.

NEW YORK STEAM ENGINE CO. MANUFACTURERS OF Machinists' Tools OF ALL DESCRIPTIONS, 98 Chambers St., NEW YORK.

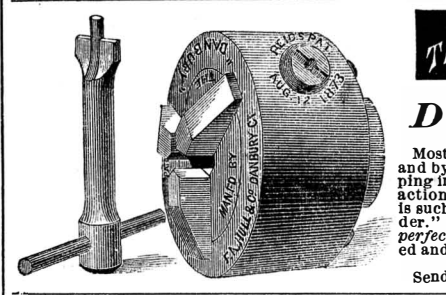

BUILDING PAPER!

Workers Wanted For WOOD'S HOUSEHOLD MAGAZINE, which with its Premiums, is one of the most attractive in the country.

ONE DOLLAR A YEAR. Commissions liberal, offering a lucrative and agreeable business to those willing to give it proper attention. Vol. XIV. begins with January, 1874. Examine our Clubbing & Premium Lists. Two first-class periodicals for the price of one.

LUBRICATORS. DREYFUS' transparent Self-acting Oilers, for all sorts of Machinery and Shafting, are reliable in all seasons, saving 75-85 per cent.

PORTLAND CEMENT, From the best London Manufacturers. For sale by JAMES BRAND, 55 Cliff St., N. Y.

SUPER-HEATERS. Save fuel, and supply DRY steam. Easily attached to any boiler. HENRY W. BULKLEY, Engineer, 98 Liberty St., New York.

Pyrometers. For testing Ovens, Boiler flues, Blast furnaces, Super-Heated Steam, Oil Stills, &c. HENRY W. BULKLEY, 98 Liberty St., New York.

Diamonds and Carbon. Shaped for crued, furnished and set for boring rocks, dressing mill burrs, emery wheels, grindstones, hardened steel and paper calendar rollers, and for sawing, turning or working stone and other purposes.

BOGARDUS' PATENT UNIVERSAL ECENTRIC MILLS, for grinding Bones, Pot Shells, Ores, Old Crucibles, Fire Clay, Gunpowder, Oil Cake, Feed, Corn, Corn and Cob, Tobacco, Snuff, Sugar, Salts, Roots, Spices, Coffee, Cocoa-nut, Flax-seed, Asbestos, Mica, Tomatoes, Saw-dust, Horn, &c., and whatever cannot be ground by other Mills.

HOUSTON'S PATENT TURBINE WATER WHEEL. Simplest, Strongest, Cheapest, Best. In the test at Holyoke, in 1872, the Houston gave the highest percentage ever shown in a reliable test and the highest average results ever obtained.



THE "DANBURY" UNIVERSAL JAW DRILL CHUCK. C. H. REID'S PATENT, AUGUST 12, 1873. Most POWERFUL Chuck made. Holds drills from 0 to 1/2, and by turning down shanks to 3/8, will hold—without slipping in the most trying work—up to one inch, inclusive.

STEAM BOILER AND PIPE COVERING

SAVES ten to twenty per cent. CHALMERS SPENCE CO., foot E. 9th St., N. Y.; 1302 N. 2nd St., St. Louis, Mo.

DOUBLE ACTING BUCKET-PLUNGER Steam Pumps ALWAYS RELIABLE. VALLEY MACHINE COMPANY, Easthampton, Mass.

T. V. Carpenter, Advertising Agent. Address Box 778, New York City.

THE PULSOMETER. The simplest, most durable and effective STEAM PUMP now in use. Will pump gritty or muddy water without wear or injury to its parts.

RANSOM SYPHON CONDENSER perfect! and maintains vacuum on Steam Engines at cost of one per cent its value, and by its use Vacuum Pans are run with full vacuum without Air Pump.



JUST PUBLISHED! Facts and Suggestions regarding the Right Choice and Right Use of Solid Emery Wheels and Emery Grinding Machinery.

HOW ABOUT YOUR PAY ROLL? Is not THIS the time—now when working forces are being reduced, and each man's effort is to see how few hands he can get along with—is not this the time to study carefully the claims of labor-saving tools?

REPAIR SHOP. New York Central & Hudson River Railroad. LITTLE FALLS, Aug. 29, 1873. WHITMAN & BURRELL, Agents, LITTLE FALLS, N. Y.

BUERK'S WATCHMAN'S TIME DETECTOR—Important for all large Corporations and Manufacturing concerns—capable of controlling with the utmost accuracy the motion of a watchman or patrolman, as the same reaches different stations of his beat.

MACHINERY, NEW and 2d-HAND-- Send for Circular, CHAS. PLACE & CO. 60 Vesey St., New York.

PROSPECTUS OF THE SCIENTIFIC AMERICAN. THE BEST MECHANICAL PAPER IN THE WORLD. TWENTY-NINTH YEAR. VOLUME XXX.—NEW SERIES.

The publishers of the SCIENTIFIC AMERICAN beg to announce that on the third day of January, 1874, a new volume commences. It will continue to be the aim of the publishers to render the contents of the coming year more attractive and useful than any of its predecessors.

Terms. One copy, one year..... \$3.00 One copy, six months..... 1.50 One copy, four months..... 1.00 One copy of Scientific American for one year, and one copy of engraving, "Men of Progress", 10.00 One copy of Scientific American for one year, and one copy of "Science Record" for 1874..... 5.00

MUNN & CO., 37 PARK ROW, NEW YORK. THE "Scientific American" is printed with CHAS. ENRU JOHNSON & CO.'S INK, Tenth and Lombard sts., Philadelphia, and 59 Gold St., New York.