

SCIENTIFIC AMERICAN

A WEEKLY JOURNAL OF PRACTICAL INFORMATION, ART, SCIENCE, MECHANICS, CHEMISTRY, AND MANUFACTURES

Vol. XX.—No. 13.
[NEW SERIES.]

NEW YORK, MARCH 27, 1869

{ \$3 per Annum.
[IN ADVANCE.]

Lithographic Fac-simile Copying Press.

The invention of Alois Senefelder, at the close of the 18th century, of printing from chemically prepared slabs of argillaceous, slaty limestone, is one of those few which was perfect at the first, or susceptible of few improvements, either in the principle or the details. Lithographic printing *per se* and lithographic printing machinery have experienced no notable change during this century. The superiority of specimens now produced over those of Senefelder and his immediate successors is due mainly, if not wholly, to the expertness and skill of experienced workmen, the principle and the mode of operation being the same.

The art may be called a branch of engraving as in some cases the stone is engraved by hand, as is a steel or copper plate. It also partakes of the character of drawing or designing, for usually the figure is drawn on the stone with crayon, pen, or brush.

Sometimes, however, the design is transferred from chemically prepared paper. For engraving, the stone is finished to a fine face and its surface washed with a weak dilution of nitric acid. The artist then uses his burin until the design is completed. The engraving is merely a slight scratching sufficient to reach beyond the influence of the acid, which is only superficial. The ink is of an oily nature and is spread over the engraving by a hand dabber, leaving its substance only in the lines, which are untouched by the acid.

When the figure is drawn on the stone by crayon, the surface is slightly roughened by rubbing two stones together with a small amount of fine silicious sand and water between the faces. The crayons and drawing ink (the latter dissolved in water, are composed of tallow, wax, shellac, common soap, and Paris or Brunswick black, or similar substances, the proportions varying in different establishments. The artist makes his design with this crayon oil, and when finished the acid is washed over the stone, when it dissolves out the alkali of the ink, leaving the insoluble portion to harden upon the stone; it attacks also the calcareous material of the stone, thus lowering the clean portions slightly and correspondingly raising the inked portions. These take readily the ink from the roller as it is passed over the stone, while those clean portions of stone, not having the design upon them, are prevented from receiving any ink by the interposition of moisture.

In transferring from paper, the ink and paper must be specially adapted to the purpose. The ink is similar to that used for printing from the stone and after the transfer is made the treatment is similar.

In printing, the stone is secured on a movable table or bed, the roller, charged with ink, is passed over its face and an application of gum arabic and water is made, which fixes the ink. This must be allowed to thoroughly dry before the stone is ready for printing, when a damp sponge is passed over the stone, removing the gum from all portions. The stone is dampened and the ink applied, which adheres only to the prepared lines of the design. This deposition of the ink, although apparently simple, is a process requiring the exercise of good judgment and the experience acquired only by long practice. The paper is then laid on the stone and the tympan, of some flexible material, as rubber, brought down over it. The stone is then traversed by means of a crank pressure being applied to the tympan and stone by an edge of wood—apple-tree being preferred—that is brought down by a powerful leverage. This method sometimes requires the services of two persons.

By the press represented in the engraving, however, only one person is required, the pressure being obtained by a weight. A is the table, and B the frame. C is the stone, supported on bearers adjusted by screws, as seen. D is the roller to which are suspended weights, E, connected with guides, F, the weights bearing on the roller, D, by means of friction rollers in each guide. G is the tympan over which the roller runs, in this machine made of leather and rubber. The stone in this machine is stationary and the roller passes over it.

It is designed for office use in multiplying duplicates of letters, notes, circulars, etc., for merchants, bankers, companies, architects, lawyers, schools, copyists, artists, clergymen, and others. The inventor says the press can print one hundred copies per hour of writings or drawings.

Patented through the Scientific American Patent Agency,

February 28, 1868. Orders should be addressed to C. C. Maurice & Co., No. 10 North William street, New York.

INTERMITTENT SPRINGS—ERROR IN THE WORKS ON PHYSICS.

Silliman's "Principles of Physics" contains, on page 226, section 286, the following description and explanation of intermittent springs:

"There exist in nature intermittent springs, the water flowing regularly for a time, and then suddenly ceasing. In these

the syphon is filled to any point, I, below the fluid, J, in which the shorter leg is immersed, the fluid will commence to flow until the level of the fluid, in the containing vessel, reaches the bottom of the shorter leg, when the flow will suddenly cease. The cause of the rise of the fluid in the shorter leg is atmospheric pressure, the pressure being removed from the section, G H, by the depending weight in the longer leg. If, when the fluid in the containing vessel becomes exhausted, it be replaced with sufficient rapidity till its level rises above the bend in the syphon, the syphon will again commence to flow, and will exhaust the fluid in the vessel, if its discharge is greater than the supply after the flow commences. Operated in this way, with a greater supply than the capacity of the syphon before the flow commences, and a less supply afterward, until the discharge from the syphon should cease, it would be an intermittent fountain, without regard to the size of the bore of the tube, which we will next proceed to consider.

The principle of the rise of the fluid in the shorter leg being the same as that of the ordinary atmospheric pump, the column, as it proceeds over the lower part of the bend, H, must remain solid and unbroken, or the tube will not act as a syphon at all. It will not remain unbroken unless the tube be so small that capillary attraction preserves its integrity, or the supply be as great as or greater than the capacity of the tube for discharge, until the end of the column in the longer leg has passed below the level, J, in the cistern; two limiting circumstances, which, if they exist in intermittent springs, have not been noticed in the works on physics, so far as we have been able to discover.

We have then to suppose, in order to substantiate the syphon theory of intermittent springs, a remittent supply, trickling into the chamber, C, Fig. 1, greater before the beginning of the discharge, and less afterward, or to suppose the channel, A B D, a capillary tube. The latter hypothesis is opposed to facts—how about the former? An entirely intermittent supply does not necessitate the hypothesis of a syphon, as that would make an intermittent spring as well through a straight channel as a syphon. A constant supply less than the capacity of the syphon, will raise the level in C to the lower part of the bend, B, Fig. 2, when it will commence to flow over, and continue to do so, thus forming a perpetual spring. A constant supply, as great as the capacity of the syphon, will also give us a perpetual spring. We can then account for intermittent springs only by supposing an *intermittent supply*, with any form of channel, or a *remittent supply*, in connection with a

syphon channel. In order that the syphon may work, we must also suppose the air to have free access to the chamber, C, which it may have through cracks and fissures, and not to have such access to the channel—a supposable case, although not a probable one. We believe the theory of an intermittent supply the only one that accounts for the facts. What is the cause of such intermission may form the subject of a future article.

The Chicago Equatorial Telescope.

Prof. Barnard, of Columbia College, has written an interesting letter to the *College Courier*, of Yale, descriptive of the great equatorial telescope of the Dearborn University of Chicago, of which the Professor says that, if it is not the largest in actual existence, he would not know where to look for a larger one mounted and in use. In comparison with the Harvard equatorial, the Chicago instrument has a light as three to two. The clear illuminating aperture has a diameter of eighteen and a half inches, while that of Harvard measured fifteen. The whole diameter of the Chicago objective, mounting included, is twenty inches. The defining power of this glass is unrivaled, as has been satisfactorily proved by the discovery, it enabled its constructor, Mr. Clark, to make of the companion of Sirius, a star which was confidently believed to exist, but which had eluded the refractors of Cambridge and Pultova (of exactly the same capacity), and the reflectors of Mr. Lessell and Lord Rosse.

The history of this magnificent telescope is singular. It was made to order for the University of Mississippi, and was to have been erected in an observatory already built and still standing at Oxford, in that State, the order for its construc-



MAURICE'S PATENT AUTOGRAPHIC PRESS.

springs, the opening, as at A, in Fig. 1, communicates with a cavity, C, by means of a channel, A B D, which has the form of a syphon. This cavity is gradually filled, until, at last, the water attains the level, B B, when the syphon is filled and the water escapes. If the syphon discharges the water faster than it flows into C, after a time its level would be lowered to D; air would then rush in by the syphon, the flow of water would cease, and would not recommence until it had again attained the level, B B."

This theory of intermittent springs is substantially the same as that given by all textbooks on physics, and it is either an



insufficient or an absurd one, as we shall proceed to demonstrate.

We shall find it necessary, however, to first discuss the operation of the syphon. A syphon is a bent tube, having one of its legs longer than the other. (See Fig. 2). When

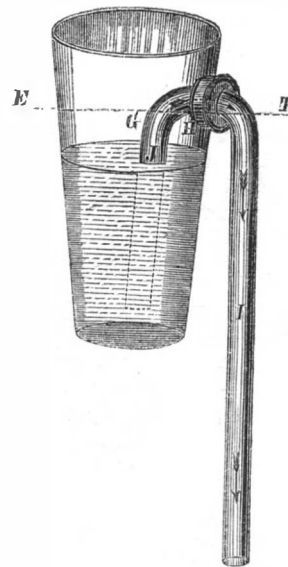

tion having been obtained chiefly through the untiring efforts of Professor Barnard himself. The war came to change the destiny of the instrument, and Professor Barnard thinks that Chicago would not have been in possession of this magnificent object glass but for the order given by the Mississippi University. It is just matter of pride that American skill and science have produced this marvel among telescopes.

DYEING IN FRANCE AND CONTRIBUTIONS OF MODERN SCIENCE TO THE ART.

BY E. R. MUDGE, U. S. COMMISSIONER TO THE PARIS UNIVERSAL EXPOSITION OF 1867.

There would be but a limited field for the exercise of taste in the textile industry without the art of dyeing, which is to tissues what the summer's sun is to the landscape, the source of all which delights the eye in light and color. While admiring the splendors of impression and color displayed upon the fabrics of the present day, we should not forget how largely they are due to the intelligence and science of the French statesmen and savans of former generations.

The great Colbert, in establishing manufactures in France, made improvements in the art of dyeing the object of special care. He published, in 1672, a set of regulations "for the dyeing of wools and the manufacture of wools of all color," and showed that dyeing was an object deserving public attention from the additional value which it confers upon many of the articles of commerce. "If the manufactories of wool, silk, and thread are to be reckoned among those which contribute most to the support of commerce, dyeing," says Colbert, "which gives them that striking variety of color by which they resemble what is most beautiful in nature, may be considered as the soul of tissues, without which the body could scarcely exist. Wool and silk, the natural color of which rather indicates the rudeness of former ages than the genius and improvement of the present, would be in no great request if the art of dyeing did not furnish attractions which recommend them even to the most barbarous nations. All visible objects are distinguished and recommended by colors but for the purposes of commerce it is not only necessary that they should be beautiful, but that they should be good, and that their duration should equal that of the material which they adorn."

These ideas bore fruit in the magnificent tapestries of the Gobelin's manufactory, and more usefully in the famous black cloths of Sedan, both of which are due to this great statesman. The art of dyeing was also during his time applied to printing cottons. The industry of calico printing was founded in Holland during the 17th century by a native of France. It was planted by a Frenchman in 1690 upon the banks of the Thames, and established about that time by a French refugee at Neufchatel, from whence it was brought back again to the country of its nativity by the celebrated Oberkampf. The regulation of the art of dyeing continued after the time of Colbert to be an object of governmental care in France; and Hellot, Macquer, and Berthollet, all eminent chemists, were successively appointed to superintend the practice of dyeing and to cultivate the branches of science which had a tendency to promote the progress of the art. Each of these chemists left practical treatises upon dyeing, of great value. The work of Berthollet, published in 1791, became the standard book of the age, since it contained not only a detailed account of the practical operations of the art, but theoretical views of the principles upon which it was founded. These works, and that of Chaptal, who while occupying the office of minister of the interior, had become interested in the art, contained nearly all that was valuable respecting the art of dyeing in any language at the close of the last century. The best informed Englishmen of that period, such as Mr. Anderson, author of the "History of Commerce," and Mr. Howe, author of an essay on bleaching, did not hesitate to admit the superiority in brilliancy of color of the articles of French manufacture of this period, and to attribute it to the fostering care of the government.

The Exposition of Paris has called forth a beautiful study on the dyeing and printing of fabrics from M. De Kaepplin. This treatise, the more elaborate work of M. Schutzenberger, published in 1867, under the auspices of the Industrial Society of Mulhouse, and the admirable report of Dr. Hoffman, president of the Chemical Society of London, published in 1863, furnish ample information as to the progress of the art in this century. A signal step in the advancement of this art was the discovery by the celebrated Vauquelin, in the early part of the present century, of the metal chromium the compounds of which have since had so many industrial applications, especially in the printing of mousselines and calicoes, as in the chromate of lead first prepared for printing cottons by Lassarque in 1819, and the oxide of chromium combined with arsenious acid to form green, applied by Courez. In 1810, Loffet introduced the process of fixing colors by means of steam to the printing of cashmere shawls, thus dispensing with the immersion of the fabrics in a bath of tincture. During the years 1837, '38, '39, '40, and '45, the beautiful discovery of Loffet received its most remarkable application in the fabrication of mousselines of wool, and wool with warps of cotton, by means of colors fixed by steam. It was this application which gave the vast extension to the manufacture of printed woolen tissues, which constitute at present the most important part of the combed-wool industry of France, and the only branch which has been successfully pursued in this country. The application of steam colors to cotton fabrics was greatly advanced by the discovery of stanate of soda by Mr. Steiner, which enables the colorist to give to the steam print a solidity and luster in which it was wanting before.

Of the modern discoveries in chemistry there is none more brilliant than that of the cheap production of ultramarine,

which was effected by Guimet in 1828, the right being secured to him by patent. This material, affording a blue color of surpassing intensity and purity, was formerly supplied by levigating the powder of the mineral *lapis lazuli*, obtained in small masses from Siberia. Its value in the arts was 125 francs an ounce, more than its weight in gold. The artificial ultramarine is produced by combining the same chemical substances, the soda, silica, sulphur, and alumina, which are found in the lapis lazuli, and is equal in brilliancy of color to the natural ultramarine. Its cost has been reduced from 6,000 francs to 6 francs the kilogram. The first impressions were made with this color, fixed by albumen upon mousselines delaine, in 1834, and in the richest fabrics of France this beautiful color replaces the duller tints formed by indigo and prussian blue, the latter dye having been fixed upon woolen tissues as a color of impression in 1836.

We must not pass over another series of inventions, although they have special relations to the printing of cotton fabrics. For the printing of cotton madder is by far the most important material on account of the permanency of its dyes. The extensive demand for this material, and the desirableness of obtaining brighter tints, have made it an object of the highest importance to free the coloring principle of the madder root from entraneous matters. The French chemical manufacturers have achieved remarkable results in this direction. In 1826, MM. Robiquet and Collin discovered in the madder root the principle *alizarine*, formerly a rose-colored dye, which the English afterward introduced as a commercial article under the name of *pincoffine*. In 1828, purpurine, also derived from madder, was indicated by the same chemist as a chemical species, distinct from alizarine. It furnishes a more vivid red than the alizarine, and is now prepared commercially. Since the period last mentioned, the coloring matter of madder has been concentrated in the form known as garancine and flowers of madder. These materials are prepared commercially in France in vast quantities, their use proving greatly advantageous, both in respect to economy and improvement of color. The dyeing powers of purpurine and alizarine are remarkable, that of purpurine being equal to forty or fifty times the same quantity of madder, and that of alizarine to that of thirty-eight times that of madder. These new substances have been found valuable in dyeing wool. Wool mordanted with alum and cream of tartar gives, with purpurine, a brilliant crimson red, and mordanted with tartar and a solution of tin gives, with purpurine, a scarlet almost as fine as that from cochineal.

(To be concluded next week.)

Skate Patents.

It will interest the lovers of that most graceful and noble exercise, skating, to know that in purchasing their skates they may take their choice from two hundred and ten kinds, all of them patented within twenty years. Mayne Reid's new magazine, *Onward* for March, contains some interesting statistics relative to this subject, from which we take some paragraphs:

From the year 1790 to 1849 no skates of any description were patented in the United States. The first skate patent was granted to Barkley & Bontgen, of Newark, N. J., on the 17th of April, 1849—the only one applied for in that year. During the years 1850, '51, '53, and '54, none were sought for, and only one in 1852. In 1855 two patents were taken out, two also in 1856, three in 1857, and one in 1858. After this, skating practice seems to have increased at an accelerated ratio, since in 1859 no less than nineteen new patents were taken out; in 1860, twenty-one; in 1861, twenty-four; in 1862, eleven; in 1863, twenty-three; in 1864, seventeen; in 1865, fifteen; in 1866, eighteen; in 1867, twenty-two, and in 1868, twenty-nine; in all, two hundred and ten! Even the war does not seem to have brought any blight on this healthful sport.

Among the recently patented skates, worth noticing, are the following: George Havell, of Newark, N. J., November 3 1868, succeeded in securing a patent for one as follows: New York club-runner, brass top throughout, one clamp back of heel, clamps on sides of feet. All three clamps worked by a long bar of steel under the sole, and turned at back of the heel by a key. The skate body is bent just in front of the heel so as to be a support to the back fastening. Joseph Lyon, of Newark, N. J., patented May 31, 1864, a stop for skates. Henry Gettely, of Brooklyn, N. Y., patented February 23, 1864, a skate with two runners, so arranged as to be close together or an inch apart. E. B. Phillips, of Cambridgeport, Mass., patented February 14, 1860, a skate made of one piece of brass, runner included. William Jordan, of Galena, Ill., patented April 7, 1868, a singular sort called a "still skate." M. C. Haight, of Geneva, N. Y., patented April 7, 1863, a very light, simple, and cheap skate, of one piece of metal, with straps over the foot. Barney & Berry, of Springfield, Mass., patented June 11, 1867, and May 12, 1868, the "New York Club," having a toe point for fancy operations—a very fine strong skate. S. A. Du Bois, of Chicago, Ill., patented June 30, 1868, a toe and heel skate. Scott & Smith, of Boston, Mass., patented December 11, 1866, one having three runners, the middle one round, others flat. The "Empire Skate" is an improvement upon the "New York Club," invented by Stone & Co., of Philadelphia, and very favorably received among skaters.

We may also notice under this head some skating adjuncts that have been thought worthy of being secured by patent: Frederick R. Willis, of Waltham, Mass., patented March 28, 1865, a skate-sharpener, consisting of two different grades of files, placed like a double T-rail. William P. Patton, of Harrisburg, Pa., patented March 10, 1868, "skate-buckling tongs," a combination of pincers, gimlet, cleaner, screwdriver for plain screws and for skate screws having heads with two cavities in them. The implement occupies small space, is made of brass, and weighs but an ounce or two. N. H. Spofford, of Boston, Mass., patented May 29, 1860, an ankle supporter, to be attached to any skate, consisting of one bar of metal to be screwed on to the heel part, and which bends (at about the height of the ankle) forward and backward. The top to be bound to the calf of the limb with a strap. H. P. Gengembre patented a device for "skating floors," November 20, 1866, consisting of a metal floor, with pipes from an engine so arranged as to flood it to any depth. J. H. A. Harvey, of Cleveland, Ohio, patented an "improved skating rink," January 28, 1868. From his model we should think it a very nicely arranged affair.

It is only a few years since the most approved skate was

built or fashioned in an entirely different manner, as regards the general position of the foot toward the ice.

A noted writer on "British Field Sports" recommends that the skate "be higher at the heel than at the toe," so as to save slipping; whereas, nowadays, it is just the reverse—being about one-quarter of an inch higher at the forward part of the skate than at the heel. Also, it was quite a curiosity then (say twenty years back) to see a skate "rock" at all; and now there is hardly a boy of ten years but has progressed enough both to use and like a "rocker."

If our readers could only take a glance at a few of the skate models, deposited in the Patent Office at Washington, they would see the great changes that have taken place in skate building. Some of the old models (only about fifteen years of age) of what was then the skate, might serve as "scarecrows" on almost any rink in Uncle Sam's dominions.

Effects of the Removal of Forests upon Climate.

An interesting letter was recently read before the Geographical Society of London, which shows the effects upon climate resulting from the clearing away of large tracts of forest. The facts given are of universal interest.

The paper was "On the Effects on Climate of Forest Destruction in Coorg, Southern India," by Dr. Bidie. This district is composed of hills and valleys, which were formerly covered with forests. The lower slopes, however, are now denuded, and the rainfall is found to decrease with the arboreal vegetation. As regards the elevated crests of the Ghauts, which intercept the rain-bearing winds of the Southwest monsoon, they would cause an abundant precipitation whether they were covered with trees or not, but the water supply and fertility of the lower slopes and plains to the East are seriously diminished by the clearing of forest on the hills, and the result is brought about in the following way: The natural forest acts as a check on the too rapid evaporation, and carrying off by streams, of the rainfall on the surface of the land. As the rain descends, it is gradually conveyed by the leaves of trees to the dense undergrowth of shrubs, and carpet of dead leaves, and below this it encounters a layer of vegetation mold, which absorbs the water like a sponge. By these, aided by the roots of trees, the moisture is transferred to the depths of the earth, and a reservoir of springs is thus found, which keeps up a perennial supply of water to the lower land. But rain falling on the bare surface of cleared lands runs off at once by the nearest water-courses, and none is retained to keep up the flow during the dry season. Beside which, evaporation is so much more abundant from a surface exposed to the rain than from land screened by a clothing of forest, and the flow of surface water tends to sweep away the clothing of soil and render a district utterly barren. There is no doubt that this is one of the main causes, in hilly countries, of drought and floods. In France, for instance, since the mountains of Auvergne and Forey have been so denuded of forests, the Loire has been constantly flooded, occasioning vast destruction of property. The same cause, in Algeria, has caused frequent droughts, and the French government have lately been considering the proposition of some scientific men to replant these districts with trees.

Extraction of Odoriferous Principles of Plants by the Use of Glycerin.

We are in receipt of inquiries in regard to the methods employed in the extraction of the odoriferous principles of flowers by the use of glycerin. The process is that of simple contact. This substance when pure is devoid of odor and not liable to turn rancid, and is therefore much superior to oils or fats for the purpose, not excluding the best olive oil.

The plan of extracting certain delicate and fugacious odors which are destroyed by ordinary distillation, used to consist in placing flowers between oiled or greased cloths or plates of glass prepared with oil or grease, after which, the essential oils were washed out from the oily matters by means of alcohol, which thus charged with perfume, became an essence or extract.

The extraction of odoriferous oils with glycerin is performed by introducing the flowers, such as those of the jasmine, hyacinth, narcissus, lilac, syringa, violet, rose, etc., into a vessel filled with glycerin, in which they are allowed to remain for three weeks. At the expiration of this time, the liquid is strained off, and contains the odoriferous principles of the flowers. The glycerin has been converted into a delightfully perfumed extract which may be used as it is, for hair dressing, or it may be dissolved in all proportions in water or alcohol forming various highly perfumed and variously scented liquids or washes. Some of the less volatile essential oils may also be transferred to ether, and from it to alcohol.

Statistics of Cotton Manufacture.

The National Association of Cotton Manufacturers and Planters has just issued a report which contains some highly interesting information. It appears that the number of cotton mills in the Northern States is at present 664, running 6,259,020 spindles, and consuming annually 385,952,021 pounds of cotton; while there are in the Southern States 86 mills, running 225,063 spindles, and consuming annually 31,415,750 pounds of cotton. In the Northern mills each spindle is made to spin, on an average, sixty pounds of cotton a year, while in the Southern mills each one spins 138 pounds, showing that a coarser quality of goods is manufactured at the South. There are, altogether, nearly 100 fewer mills in operation now than there were in 1860. The total consumption of cotton for manufacturing purposes last year was 450,000,000 pounds, which, at the usual estimate of 400 pounds to a bale, equals 1,125,000 bales, or nearly one half the production of the United States. The consumption in 1868, in Europe and the United States, was 2,094,105,000 pounds, against 1,976,520,000 pounds in 1858, and 2,284,901,000 pounds in 1859. At the present relative prices of raw cotton and cotton cloth, there is no profit on the manufacture of the latter.

Adulterations of Food.

We have alluded to the results of some investigations, recently published in the *New York World*, regarding the adulterations of current articles of food in the United States. Some of our transatlantic exchanges have alluded to the subject in a manner calculated to imply that the Yankees are experts in this sort of thing. It would seem, however, that such deception is not by any means confined to this country. A committee composed of a large number of very able men, chemists, physicians, etc., being appointed by the British Parliament to investigate the subject, report that they cannot avoid the conclusion that adulteration widely prevails, though under circumstances of very various character. "As regards foreign products some arrive in this country in an adulterated condition, while others are adulterated by the English dealer. Other commodities again, the product of this country, are shown to be in an adulterated state when passing into the hands of the dealers, while others undergo adulteration by the dealers themselves. Not only is the public health thus exposed to danger, and pecuniary fraud committed on the whole community, but the public morality is tainted, and the high commercial character of this country seriously lowered, both at home and in the eyes of foreign countries. Though happily very many refuse, under every temptation, to falsify the quality of their wares, there are unfortunately large numbers who, though reluctantly practicing deception, yield to the pernicious contagion of example, or to the hard pressure of competition forced upon them by their less scrupulous neighbors."

Without enumerating all the adulterations detected by the committee, the following list will show that English ingenuity in the art of cheating is not to be ranked as very inferior to that of other nations:

"Some of the leading articles which have been proved to be more or less commonly adulterated, are: Arrowroot, adulterated with potato and other starches; bread, with potatoes, plaster of paris, alum, and sulphate of copper; bottled fruits and vegetables, with certain salts of copper; coffee, with chicory, roasted wheat, beans, and mangle wurzel; chicory, with roasted wheat, carrots, sawdust, and Venetian red; cocoa, with arrowroot, potato flour, sugar, chicory, and some ferruginous red earth; cayenne, with ground rice, mustard husks, etc., colored with red lead; lard, with potato flour, mutton suet, carbonate of soda, and caustic lime; mustard, with wheat flour and tumeric; marmalade, with apples and turnips; porter and stout (though sent out in a pure state from the brewers), with water, sugar, treacle, salt, alum, cocculus indicus, grains of paradise, nux vomica, and sulphuric acid; pickles and preserves, with salts of copper; snuff, with various chromates, red lead, lime and powdered glass; tobacco, with water, sugar, rhubarb, and treacle; vinegar, with water, sugar, and sulphuric acid; jalap, with powdered wood; opium, with poppy capsules, wheat flour, powdered wood, and sand; scammony, with wheat, chalk, resin, and sand; confectionery, with plaster of Paris and other similar ingredients, colored with various pigments of a highly poisonous nature; and acid drops, purporting to be compounded of Jargonelle pear, Ribston pippin, lemon, etc., with essential oils, containing prussic acid or other dangerous ingredients."

Further investigations, an account of which we omit, seem to indicate that pure articles of diet are rather the exception to the rule among our self-complacent critics. It is impossible in this connection not to recall the lines of Burns.

Oh wad some power the giftie gie us
To see ourselves as ithers see us,
It wad frae mony a blunder free us,
And foolish notion.

The United States Coast Survey.—Interesting Experiments.

For some time past, the United States Coast Survey officers, have been engaged in making astronomical observations between Cambridge University and the cities of the West, using the telegraph to aid them in their labors. In order to arrive at the mean time between the Atlantic and the Pacific, the one represented by Boston and the other by San Francisco, the wires of the Western Union Telegraph have been nightly brought into use for nearly a month past. The wires were connected with a chronometer at Cambridge in such a manner that the main circuit is broken and instantly closed again at every beat or tick of the time-piece, and the result is that each second of time, as marked by the chronometer at Cambridge, goes forth from the university on the Atlantic coast, and, with almost the speed of light itself, hurries on over the magic wire, passing through intermediate cities, towns, and villages, across rivers, over mountains and along the open country, until it finally reaches the recording instrument on the Pacific coast, in all its original fullness of pulsation. Think of it once! The ticks of a clock in Boston are heard and recorded in San Francisco almost in the same instant that they reached the ear of the observer in the first named place!

So perfect were the connections and the workings of the wires that, had any one gone into the office of the Western Union Telegraph in this city, at any time during the time when the experiments were going on, he could have heard the ticking of the chronometer at Cambridge, as the signals were rapidly transmitted to the Pacific seaboard. For five minutes the tick! tick! tick! goes on, and then all is quiet. Presently San Francisco telegraphs Boston "All right; your second signals came good, and have been recorded for five minutes. Go ahead five minutes more." Again, tick! tick! tick! for five minutes, and then San Francisco says again: "All right, are you ready to take my signals?" And the answer from Boston is: "Yes, go ahead." "Tick! tick! tick!" says San Francisco for the allotted five minutes, and Boston says, in his turn: "All right!"

The signals are perfect, yet the question is not solved. The loss of time in the transmission of the signals between one point and another is to be computed, and the experimenters have the problem of how to measure that time, for solution. This is, however, only a small part of the labor. Another wire is switched on at Boston, a repeater is added, and the question is solved. In a trifle less than sixty seconds, one minute, the signals go to San Francisco and return to Boston, having traveled about six thousand miles.

The experiments are now closed, but they have been entirely successful. The route is from Boston through Albany, Buffalo, Cleveland, Detroit, Chicago, Omaha, Cheyenne, Salt Lake City, Virginia City, in Nevada, to San Francisco and return.

This triumph of art over what appeared to be insurmountable difficulties has been the greatest yet recorded, inasmuch as space, so to speak, has been totally annihilated. The true difference in the mean time between the two points has not yet been fully announced.

Effects on Man of Residence at Great Altitudes.

Prof. Robert von Schlagintweit, the celebrated traveler, at a recent meeting of the Boston Society for Medical Improvement, made some very interesting remarks upon the effects of high altitudes upon the human system. We extract from the *Boston Medical and Surgical Journal* a synopsis of his remarks which are of value, as they are based upon personal experience and observation in the highest regions of Asia, through which Prof. von Schlagintweit has traveled extensively.

"There is a high above which human life is impossible; in a balloon, Mr. Glaisher fainted when 32,000 feet above the level of the sea; probably no man could live at an elevation greater than 34-36,000 feet; this will, however, depend much on the state of the atmosphere, the idiosyncrasies of individuals, and the habit of living in high places. The Professor, himself, on first reaching an elevation of 17-18,000 feet, felt great inconvenience and distress, but at another visit was not much affected. People living at a moderate elevation, on going higher, suffer full as much as the unaccustomed traveler. In 'High Asia' the effects of elevation are shown by headache, hæmoptysis, dyspnoea, anorexia, muscular debility, and low spirits, all increased at night, and at times every one gasps for air, apparently in vain; moments occur when every one believes that he must inevitably be suffocated. In day time epistaxis may occur, but if the nose is not too much irritated it seldom occurs. He had never seen bleeding from the eyes, lips, or ears. All these symptoms disappear as soon as one begins to descend. In the Andes, it is said, beside these symptoms, are also intense headache, swoons, bleeding from the nose, lips, gums, and eyelids, especially the *tunica conjunctiva*. The high at which these symptoms come on among the Andes is not nearly so great as in High Asia; in the latter country being not below 16,500 feet, while in the Andes the effect of high has been repeatedly felt as low as 10,700 feet, lower than anywhere else. No satisfactory explanation of this fact has yet been given. Prof. S. thought it might be owing to the different geological construction, but the existence of volcanoes in the Andes would not wholly account for the difference. In balloons, these symptoms do not come on till a much greater high is reached, bodily exertion rendering one much more likely to suffer; in a balloon, the passengers keep perfectly still, any exertion, at a great high, causing intense depression and greatly heightening the pulse. Cold does not increase the intensity of the suffering, but wind decidedly. One could stay for days at heights of 16,500 feet and not suffer during the first portion, but at evening a breeze usually sprung up, rendering every one sick; in the morning the appetite came back and the bad symptoms were gone. The effect of great heights is influenced by the state of the atmosphere (which is always better in the morning than in the evening), the existence of wind, or clouds, or electricity. There is a great decrease in the atmospheric pressure, the barometer at the height of 22,259 feet showing only 13.8 inches. In High Asia, at a height of 18,600 or 18,800 feet, the atmospheric pressure is one-half of that at the level of the sea. These symptoms, which all are liable to in great heights, prevent human beings from living there, even if all conditions are at hand for their thriving well.

"In none of the pastures in Thibet is the high greater than 16,320 feet, and they are only used in certain portions of the year. A French author, Paul de Carmoy, has described a village in the Peruvian Andes, named Pueblo de Ocoruro, at a height of 18,454 feet, whose inhabitants spend all the year there, but from his own experience, Prof. von Schlagintweit thinks this impossible; Carmoy's statement rests either on an erroneous observation or on a wrong measurement; he has probably mistaken a transitory settlement, only inhabited for a few days, for a permanent abode.

"Dr. Parks said, some years ago he ascended Monte Rosa, and when near the summit, in the midst of a flurry of wind and snow, had an attack of dyspnoea, and other disagreeable feelings, which all passed away on reaching the summit.

"Prof. von Schlagintweit said these symptoms were not usually felt on the Alps, which were only on the confines of the elevation at which these symptoms were likely to occur. They might be felt in an exceptional case, in a storm, as in Dr. Parks' experience, or by people of highly nervous temperaments.

"Why should this influence show itself at so much lower an elevation among the Andes than in the Alps or elsewhere? Whole villages live in Asia at the height of 10,500 feet above the level of the sea. The inhabitants are robust, with well-developed chests; their stature is somewhat less than that of Europeans or Americans, but their strength is enormous, that of the women as well as the men. The diet varies with the race, some living on vegetable, some on animal food alone,

The Hindoos live principally on rice; they also make use of an intoxicating liquor made of millet.

"Animal traces are found at very great heights; the yak (*Bos grunniens*) at 19,400 feet, wild horse (*Kyang*), and several species of wild sheep and ibex at 18,600, but very few birds.

"As to the diseases: in Thibet we find goitre but seldom, while it is common in some Himalaya valleys; rheumatism is very common, as is also constipation; smallpox causes fearful ravages in Thibet; no apoplexy; no phthisis, but, on the contrary, consumptives find great relief in these high altitudes. Prof. von Schlagintweit anticipates happy results from the study of the hygiene of high regions."

The Twig-Girdler.

We have been puzzled for a long time to know what insect it is that girdles and occasionally amputates the twigs of various trees in the manner shown in the following engraving. The mystery has at length been solved by one of our correspondents, Mr. Geo. Burnside, of South Pass, Ill., detecting the culprit in the very act. Upon examining two specimens, kindly sent to us by that gentleman, the girdling insect proves to be one of the rarest of our capricorn, or long-horn beetles (the *Onidæres cingulatus* of Say, color, a, grayish-brown). And now that we have thus been enabled to recognize the species, we find that, so far as regards the girdling of hickory twigs by this beetle, the discovery was made and published more than thirty years ago by Prof. Haldeman. Possibly the amputation of pear twigs, and especially of persimmon twigs, which we have ourselves noticed to be so

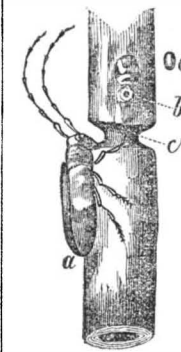

very common in South Illinois, in consequence of such girdling, may be effected by a distinct species; but, as Mr. Burnside says, that he discovered the very same insect, which he had seen actually girdling hickory twigs "under very suspicious circumstances" upon a pear tree, the probability is that it is the same species that operates upon all these three trees.

The twig-girdler, according to Prof. Haldeman, "may be seen in Pennsylvania during the last two weeks in August and the first week in September, feeding upon the bark of the tender branches of the young hickories. Both sexes are rather rare, particularly the male, which is rather smaller than the female, but with longer antennae. The female makes perforations, b, in the branches of the tree upon which she lives, which are from half-inch to a quarter of an inch thick, in which she deposits her eggs (one of which is represented of the natural size at c). She then proceeds to gnaw a groove, of about a tenth of an inch wide and deep, around the branch and below the place where the eggs are deposited, so that the exterior portion dies, and the larva feeds upon the dead wood."—*American Entomologists*.

Seventeen and Thirteen Year Locusts.

There is probably no one American insect more intimately connected with the history of the United States, and of which more has been written, than the 17-year cicada. It is scarcely necessary to tell Americans that, as the name implies, this insect generally requires seventeen years to undergo its transformations; remaining, with the exception of about three months, the whole of this time under ground. There is not a parallel case, that we know of, within the whole range of natural history; but though so much has been written about this cicada, yet some of the most interesting facts relative to its history were unknown till the present year.

We have discovered that beside the 17-year broods, the appearance of one of which was recorded as long ago as 1633, there are also 13-year broods; and that, though both sometimes occur in the same States, yet in general terms, the 17-year broods may be said to belong to the Northern, and the 13-year broods to the Southern States. It so happened that one of the largest 17-year broods, together with one of the largest 13-year broods, appeared simultaneously in the summer of 1868. Such an event, so far as regards these two particular broods, has not taken place since the year 1647, nor will it take place again till the year 2089.

There are absolutely no perceptible specific difference between the 17-year and the 13-year broods, other than in the time of maturing.

The season of their appearance and disappearance differs somewhat with the latitude, though not so materially as one might suppose. According to the records, they appeared the past season earlier in the South than in the North; but the last half of May can be set down as the period during which they emerge from the ground, in any part of the country, while they generally leave by the 4th of July. As is the case with a great many other insects, the males make their appearance several days before the females, and also disappear sooner. Hence, in the latter part of the cicada season, though the woods are still full of females, the song of but very few males will be heard.

Their natural history and transformations have been sufficiently described in the standard works of both Harris and Fitch, and we shall simply mention a few facts not recorded by them.

Mr. S. S. Rathvon, of Lancaster, Pa., who has himself witnessed four of their periodical visits, at intervals of seventeen years, has communicated to us the following very ingenious provision, which the pupa made the past season, in localities that were low or flat, and in which the drainage was imperfect. He says: "We had a series of rains here about the time of their first appearance, and in such places, and under

such circumstances, the pupas would continue their galleries from four to six inches above ground (*a*, full view, *b*, sectional view), leaving an orifice, *c*, of egress even with the surface. In the upper end of these chambers the pupas, *c*, would be found awaiting their approaching time of change. They would then back down to below the level of the earth, as at *d*, and issuing forth from the orifice, would attach themselves to the first object at hand, and undergo their transformations in the same manner."

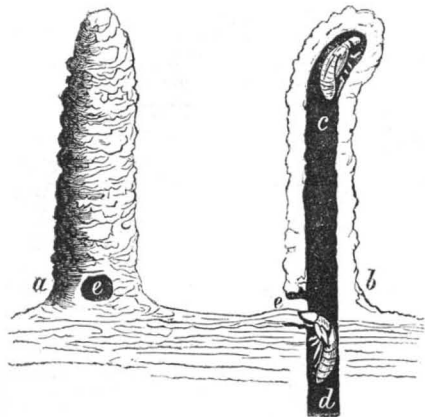

Mr. Rathvon kindly furnished us with one of these elevated chambers, from which the above drawings were taken. It measured about four inches in length, with a diameter on the inside of five-eighths of an inch, and on the outside of about one and a quarter inches. It was slightly bent at the top and sufficiently hard to carry through the mail without breaking. It bore a great resemblance to the tube of the mason bee, but the inside was less smooth and covered with the imprints of the spines with which the fore legs of the builder are armed. In a field that was being plowed, about the time of their ascent, we found that single, straight, or bent chambers were the most common, though there were sometimes several branching near the surface from a main chamber below, each of the branches containing pupa. The same observations have been made by other parties.

When ready to transform they invariably attach themselves to some object, and, after the fly has evolved, the pupa skin is left still adhering. The operation of emerging from the pupa most generally takes place between the hours of 6 and 9 P. M.; and ten minutes after the pupa skin bursts on the back, the cicada will have entirely freed itself from it. Immediately after leaving the pupa skin, the body is soft and white, with the exception of a black patch on the prothorax. The wings are developed in less than an hour, but the natural colors of the body are not acquired till several hours have elapsed. These recently developed cicadas are somewhat dull for a day or so after transforming; but soon become more active, both in flight and song, as their muscles harden. For those who are not informed of the fact, we will state that the males alone are capable of "singing," and that they are true ventriloquists, their rattling noise being produced by a system of muscles in the lower part of the body, which work on drums under the wings.

Upon leaving the ground to transform, the pupas are attacked by different quadrupeds, by birds, by cannibal insects, such as ground-beetles, dragon-flies, soldier-bugs, etc.; while hogs and poultry of all kinds greedily feast upon them. In the perfect fly state they are attacked by at least one insect parasite; for dipterous maggots may occasionally be found in their bodies. In this state they are also often attacked by a peculiar fungus. One of our correspondents, Dr. W. D. Hartman, of Westchester, Pa., speaking of the occurrence of this fungus in 1851, says: "The posterior part of the abdomen, in a large number of male locusts, was filled by a greenish fungus. * * * The abdomen of the infected males was unusually inflated, dry, and brittle, and totally dead while the insect was yet flying about. Upon breaking off the hind part of the abdomen, the dust-like spores would fly as from a small puff-ball."

The injury to fruit trees, which the female causes by her punctures, is often quite serious. This is especially the case in a young orchard or in a nursery. When the wind is high the cicadas may, with its aid, be driven to some extent, but without the aid of the wind they cannot be driven at all; as when you start them they are just as likely to fly behind as before you. Indeed, when they are once in the fly state, and as numerous as we have seen them the past season, we are obliged to confess, after experiments involving about \$200, that there is no available way of preventing their ruinous work. While in their feeble and helpless condition, however, as they leave the ground, they can be destroyed with but little trouble.

In the year 1863, and at intervals of seventeen years thereafter, they will probably appear in the valley of the Connecticut river. According to Dr. Asa Fitch, they appeared there in 1818 and 1835; although, strange to say, there seems to be no record of their having appeared there in 1852. Hence, this may be considered as a somewhat problematical brood.

In the year 1870, and at intervals of seventeen years thereafter, they will, in all probability, appear in what is known as the "Kreitz Creek Valley" in York county, Pa. This brood appears to be quite local.

In the year 1871, and at intervals of seventeen years thereafter, they will in all probability appear around the head of Lake Michigan, extending as far east as the middle of the State of Michigan, and west an unknown distance into Iowa. Also in Walworth county and other portions of southern Wisconsin, and southward into Illinois.

They will also appear in the same years in the southeast by

eastern part of Lancaster county, Pa., in what is called the "Pequasa Valley," having appeared there in vast numbers in 1854.—*American Entomologist*.

VELOCIPEDE SUMMARY.

The *English Mechanic and Mirror of Science*, gives an engraving and a description of a velocipede used in the last century by M. Richard, a physician of Rochelle, France, which is a singular affair. It is a four-wheeled vehicle, the two hinder ones being the drivers. It has a canopy to protect the rider from sun and rain, and a box for a footman behind the canopy. The footman was a footman indeed, as well as in name, and his office was no sinecure. While the doctor reclined at his ease and steered the vehicle by means of two cords attached to the opposite ends of a lever on the forward wheels like that used on the modern machine, the footman propelled the vehicle by means of treadles acting by pawls upon ratchet wheels attached to the hinder axle.

A correspondent of the same journal suggests the use of sails as an assistance in propelling velocipedes. It is well known that sails have been used with considerable success in propelling land vehicles and ice boats, and it is not improbable that an application of a small sail to the bicycle could be made that would materially aid in its propulsion. When a lad, we used to amuse ourself by using a hemlock bough as a sail when skating, and have found that we could thus make very considerable progress without using the legs as motors. A sail, having an area of from nine to sixteen square feet, would, with the wind well aft, give a propelling force sufficient to drive a velocipede on a smooth and level road, and would prove a great assistance in ascending a grade. A wind blowing at the rate of twenty-five miles an hour, which is only a brisk wind, would give a tractive force of nearly fifty pounds upon a sail four feet square.

The same journal also gives an account of some water velocipedes, which we think are inferior to some invented in this country. We have an engraving of a water velocipede in preparation, which will in due time be laid before our readers.

With the approach of the season for tours in rural districts by artists and sportsmen, considerable attention is being paid to accessories for velocipedes. Those which seem to have occupied the thoughts of foreign inventors most, are valises, lanterns, oil bottles, velocipede covers, supporters, and reckoners. These articles form quite a staple in the foreign patent business, but as yet very few applications in this field have been made in the United States. During the summer months there will be a demand for all articles of this kind, and inventors will do well to anticipate it.

The Prince Imperial of France has ordered twelve velocipedes, for the use of himself and friends. He is said to be passionately fond of the sport. In other parts of Europe, England in particular, the use of velocipedes is rapidly increasing.

We have been shown an ingenious model, calculated to adapt the velocipede to snow travel, the particulars of which we are not at liberty to publish. The same principle, if it proves successful, may be applied to velocipedes designed to be used on large and level tracts of loose sand.

There seems to be a fertility in invention in this field altogether surprising, and which is alone sufficient to guarantee the non-ephemeral character of the favor in which it is now held.

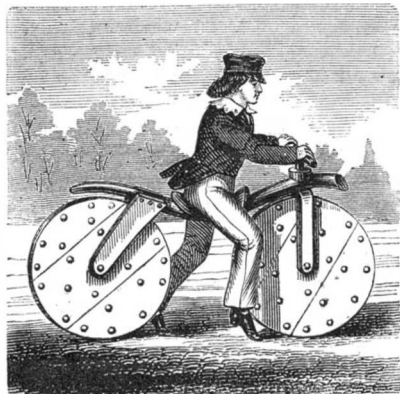

We herewith give a cut of a velocipede made in 1823, at Norfolk, Conn., and a communication in regard to it.

"In a small New England village, about the year 1823, a cute Yankee boy 'might have been seen' (as G. P. R. James used to say), in fact, was seen tearing round on a VELOCIPEDE of his own construction, to the astonishment of the villagers and his own great delectation. The 'machine' was of rather a rude construction, as shown in the above cut, the wheels being of boards nailed together crisscross, and the frame of such 'stuff' as a farmer's woodpile could furnish; but it would 'go like fun.' In principle, and even in form, it was identical with the present bicycle, the crank being omitted, and on which some one, more witty than wise, claims a patent. There were the two wheels, tandem; the forward one 'axled in the jaws of a depending bar, pivoted in the frame and turned by a horizontal lever bar;' and it is presumed to have been constructed after a 'description' in some 'printed publication,' boys in those days not being thought adequate to the invention of anything! It was propelled by the toes (not the flat foot) lightly touching the ground; and, though not as 'fast' as the crank-y concerns of the present hour, did very well for a little village and a country boy.

"That village was Norfolk, Litchfield county, Conn.; and the boy (an old boy now), your correspondent and admiring reader."

I. I. PEASE.

Stockbridge, Mass.

Another correspondent from Indianapolis, writing under

date of Feb. 16, states that our weekly velocipede summary excites much attention and interest in that city, and gives us some items of interest. He says that perhaps no city has caught the fever more readily than Indianapolis. "As soon as velocipedes could be built they were eagerly bought up by our young men, who soon became more or less skilled in riding; and in order to test the adaptability of the machines to travel on common roads, a party has been formed to make a trip to Richmond, in this State, as soon as the roads are in good order, so that the cry among velocipedists now is 'On to Richmond.'"

"Last evening, at the rink, a race for a silver cup was announced to take place between some professional riders and those of our young men who chose to enter the lists. After strong efforts, on the part of the professionals, to agree upon a distance of three times round the floor, it was decided to make it eleven times round, which is equal to a mile, and each one to run separately against time. Without specifying the performance of each of the ten riders, I will speak of the victor—a young gent of this city, who exhibited the most perfect control of his machine, riding with equal elegance and precision either with or without using his hands. He made the mile in three minutes and six seconds, which, as far as I have seen, is the best time yet made on occasions of this kind. The size of the wheels is thirty-six inches front and thirty inches back. The excitement of the great crowd of spectators was intense, as with perfect coolness and unerring regularity he made his rounds, apparently sans effort, in an average of less than seventeen seconds."

This correspondent also makes some good suggestions in regard to the construction of velocipedes which we omit, as they have been for the most part anticipated in our columns.

The *Velocipedist*, speaking of the expense entailed in the use of velocipedes, says:

"The two-wheeled velocipede is the animal which costs but little to purchase, and still less to keep. It does not, like one Zedechias mentioned by an old historian, eat cart loads of hay, with carts, horses, and drivers as a relish, just to amuse Louis le Debonnaire, or any other sovereign. It does not, like Jeshu run, wax fat and kick. It is easy to handle. It never 'rares up.' It won't bite. It needs no check rein or halter, or any unnatural restraint. It is light and little; let alone, it will lean lovingly against the nearest support. It never flies off at a tangent unless badly managed, and under no circumstances will it shy at anything. It is not ludicrous, like the young mule, nor does it, like the Morgan colt, cut up in a ridiculously corybantic manner, nor does it in other ways disgrace the memory of its inventor. In its movements it is all grace. Its one gait is so uniform and easy and beautiful to look at, and simple to analyze, that it would be a shame to speak of a trot in the same breath. When its driver driveth furiously, even as did Jehu, the son of Nimshi, then there may be danger to him who obstructs the way, and will not make room for the flying steed. But otherwise not. When we have nationalized the stranger, do not let us forget his origin, but where many smooth roads meet, erect to his memory, and in honor of the inventor, a brave monument like that which surmounts the grave of him who first gave us pickles, and taught the world how to cure and barrel the bony herring. Let it not be said that the maker of the first bicycle went unrewarded by the descendants of that posterity who forgot Ctesibius, the first organ builder, or him who introduced the gridiron, or yet those other anonymous benefactors to whom we owe the benefits and blessings derived from the use of door knobs and buttons."

An exciting race took place very recently in the Horticultural Velocipede Academy, in Boston. It was both a fast and slow race.

The slow race was introduced first, there being about six entries, for a purse of \$500, to be awarded to the rider making the circuit of the hall three times in the longest time, each contestant, in case of making a "foul," to have the second trial. The race lasted about an hour and a half, the following time being made: Mr. Geo. Marsh (the winner), 4.02; Mr. Hamblin, of East Boston, 3.54; Mr. Goddard, 3.34; Mr. Clark, 3.23; Mr. Sandford, 3.18; Mr. Gardner, 3.13.

The second or fast race was a match for a purse of \$100, distance one mile or twenty-four times around the hall, between Mr. Clark, of Chelsea, and Mr. Hamblin, of East Boston, both riders to start at the same time from opposite sides of the hall. After some falls, and amidst vociferous cheering, Mr. Hamblin was declared the winner in 4.52.

A word of advice to the proprietors and conductors of velocipede halls. The congregation of "roughs" and rude boys at some of these places, is a serious drawback to the amusement of those who pay for their amusement. The interests of all concerned, and the prosperity of these popular resorts, will be consulted by the exclusion of such characters, by proper regulations.

INTERNATIONAL EXHIBITION OF HOUSEHOLD ARTICLES.—It is announced that information has been received at the Department of State, that the Society for the Encouragement of Manufactures and Mechanical Industry in the Netherlands, proposes to arrange an International Exhibition of articles for daily household use, at Utrecht, in the months of August and September, 1869. The principal object of this exhibition is to bring to the knowledge of the workman such articles of industry of different countries, at a low price, as may combine usefulness with durability, so that he may be enabled by judicious economy to improve his condition.

A RECORD of seventy-five boiler explosions in England shows that twelve were in mines and eleven in iron and engineering works.

Correspondence.

The Editors are not responsible for the Opinions expressed by their Correspondents.

Single-acting Toy Steam Engine.

MESSRS. EDITORS.—The description of the toy steam engine, published with illustrations in No. 5, current volume of your valuable journal, was interesting to me, because I have one something similar which I built as evenings' amusements while an apprentice. I think it is easier to make than the one you describe.

The boiler head is a brass casting, A, of a triangular form, having a circular flange, B (dotted lines in Fig. 2), fitting into the boiler, C, which is of sheet copper or brass, spun from a single piece. The cylinder, D, oscillates on a screw, E, passing through the flange of the cylinder head, F, and the boiler head, and secured by a set nut, G, under the plate. The face of the flange of the cylinder head is held to the surface of the boiler head by a spiral spring under the head of the screw, as seen in Fig. 1, which is a side elevation or vertical section-

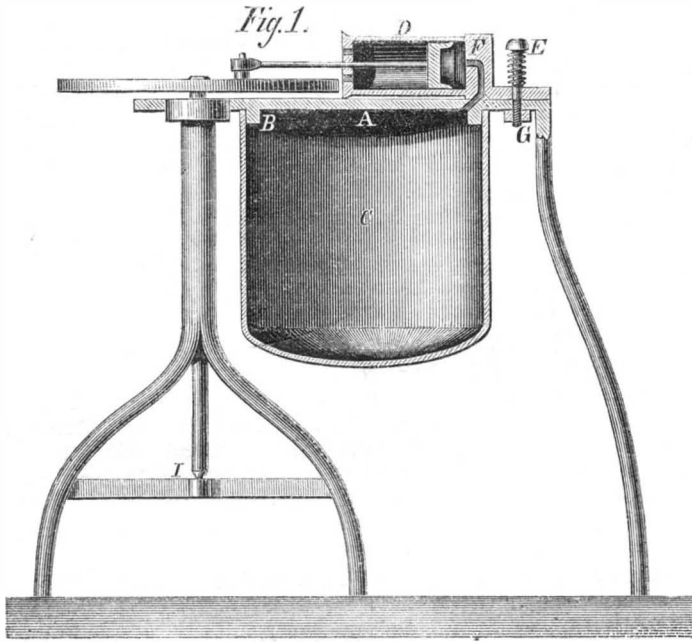

while Fig. 2 is a plan, or top view. This spring forms also a safety valve by permitting an over-pressure of steam to lift the face of the cylinder head slightly, through the medium of the port seen leading from the boiler through the upright portion of the cylinder head to the cylinder. (The port shown by the dotted lines in Fig. 1 is the exhaust, the space between the two being shown in Fig. 2 where one is represented closed and the other open).

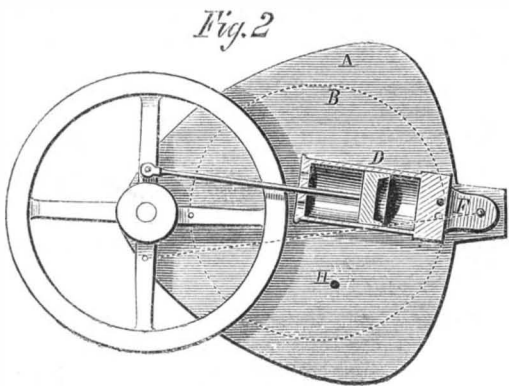

The piston is turned concave with a thin edge on the steam side, left slightly larger than the bore of the cylinder, and which may be spread with a burnisher when it leaks, thus forming a spring packing. The boiler has no gage cock, although one might be easily attached, and it is filled with water through a hole, H, Fig. 2, which may be plugged with a small screw. The leg at the wheel end is made of a tube through which the shaft of the wheel passes, its end resting on a step in a cross-piece, I, to receive which the pipe is split about half its length forming two feet. It will be seen that the wheel runs through a horizontal plane, being mounted on a vertical shaft. Heat is applied under the boiler by a gas jet or a small spirit lamp. The joints are all made with hard solder. Holes in the wheel end of the cylinder admit the atmosphere for the return stroke. The machine is very simple and easily constructed. It is a source of great amusement, as it hums like a top.

DANIEL DAVIS, JR.
Princeton, Mass.

Incrustations on Iron.

MESSRS. EDITORS.—I have just been reading in the SCIENTIFIC AMERICAN the article on boiler incrustations. I have frequently noticed in our kitchen an iron pot, smooth as glass on the inside, which the old cook keeps forever over the burning coals, with boiling water; beside that stands the tea-kettle, also iron, but rough as a grater inside. Now, in the pot the water never deposits crust, nor is there any sign of it; but in the kettle you might almost build a brownstone house with the incrustation if you could get it off.

The idea occurred to me, that all boilers could be made smooth inside (and you could not have them too smooth), they ought to be slippery as ice; or why not line them with porcelain as all our cooking utensils are, which are often over tremendous fires? Let the inside only be smooth, and it ap-

pears water could not then incrust them. In our pump is sulphate of lime.

MRS. EDMUND PRATT.
Bridesburg, Philadelphia, Pa.

[Cast-iron cooking utensils are generally made of very hard iron. When of soft iron they are liable to corrode as well as to gather incrustations. The very hard iron will keep clean. It is obvious that such hard iron could not be used in making steam-boiler plates, for it could not be wrought, and would not have the requisite tenacity. The conditions of a culinary vessel and a steam generator are not the same. The temperature of the interior of a kitchen pot cannot rise much above the boiling point of water, 212° Fah., but that of the steam boiler not unfrequently rises to 365° Fah.—EDS.]

Rat-proof Buildings.

MESSRS. EDITORS.—I noticed an article from the American Builder relative to the discomforts of the people of Chicago, occasioned by the vast number of rats which infest that city, and asking if any one can invent a style of building which shall be rat proof.

I have wondered many times, that the builders and proprietors of the grain elevators and large warehouses of the West have not ere this adopted the English plan of making their buildings rat proof. The same material, in a more finished state, is used for first class dwelling houses. If used by the people of Chicago, they will be free from the encroachments and destructiveness of rats, as well as the filth, bad odor, and the disagreeable gnawing sounds caused by them.

The plan adopted in England is to have the floor of slate, sawed and planed to uniform sizes and thickness. The walls are also covered in the same manner with sawed and planed slats, well jointed and secured to the wall or studding with screws, which makes each room as secure against rats as an iron or stone box would be. The slate used for the floor is from one to two inches thick, and that for the walls half an inch thick. For warehouses, elevators, and such buildings, it would be less expensive to use it as it comes from the saw and planer without being sand-rubbed; but for costly dwellings the slate for the walls is marbleized, by which process a perfect imitation can be made of any of the foreign marbles, rendering the rooms at once gorgeous and beautiful in appearance.

The Vermont slate, which is of handsome light variegated colors, polished to a glossy surface, would appear finely and be preferred by many. But the imitations of light foreign marbles, such as Sienna, Lisbon, brocatelle, porphyry, and the like, would be richer and livelier in color, making the rooms more pleasant and light. The slate is wrought into different shapes and forms to suit the taste; some in panels, others to represent blocks of marble of one or of different colors. For plainer dwellings it may be used in its natural color without polish or extra finish. There is no doubt but that slate used in its plain form for the floors and walls of stores, mills, and elevators, and even houses, would render them rat as well as fire proof.

I. I. W.

Fairhaven, Vt.

Crank Pins of Inside Connected Locomotives.

MESSRS. EDITORS.—I propounded the simple question, "Why the inside connected engine requires a crank pin so much larger than an outside connected one?" and by way of answer a gentleman, who is a first rate mechanic, asks, "Why does the axle of a locomotive need to be larger than the crank pin?" The crank pin and axle perform two different offices, and in the case of the inside connected locomotive there is very little difference between the sizes of the two parts.

I will answer my own question in this way: There is no need of the pin being any larger than for an outside connected engine, for it would break of any size if exposed to the same influences. Since the crank shaft is one solid forging, and of the worst form to bear sudden shocks or jars, it seems to me that the frequent breaking of them is from natural causes; that is, sudden strains from the track, unrelieved by any spring or counterforce. The action of the pistons, in addition to the sudden elevation of one side two inches or more from a plane, causes a very severe twist, which not unfrequently breaks the solid crank pin of six inches, while the four-inch pin (outside connected) escapes. The outside connected engine has no such strains to encounter in its crank pin, having merely to turn the wheel. I hope this is not "an evasive answer."

EBERT P. WATSON.

Do We Measure Horse Power Correctly?

MESSRS. EDITORS.—When we wish to find the actual horse power of a steam engine, and compute the same by multiplying area of cylinder by stroke of piston, pounds of steam, and number of strokes per minute, without other qualification, the result is erroneous; as, for instance, apply the foregoing rule to a steam engine furnishing power for a machine shop, and running at the rate of seventy-five revolutions per minute, and let the result in horse power be thirty; then disconnect, throw the belting off the power wheel, use the same amount and pressure of steam, and the number of revolutions will be doubled on account of outside resistance being removed. Now, measure the horse power by same rule, and the result will be sixty-horse power, which is evidently absurd; for it is equal to saying that the engine uses most horse power when doing least work, and least horse power when doing most work.

It appears to me, that the actual horse power of an engine, is only and simply the amount of power thrown off and made

use of, and should be competent apart and distinct from the power consumed in the engine, *per se*, and I therefore beg to suggest the following rule for computing true horse power.

Calculate, by present method, the horse power of any engine doing actual work, at any given number of revolutions, and then find the horse power consumed in producing the same number of revolutions when not doing any work; subtract the one from the other and the result will be the true horse power of the engine.

To assist purchasers, it should be incumbent upon all builders of, and dealers in steam engines, to know the exact horse power consumed at any given velocity in any engine, *per se*, they may have for sale. It must be admitted that a better test of the superior economy of one man's make of engine over another, could scarcely be had than that of the amount of steam consumed in running any engine alone.

New York city.

MATHEMATICIAN.

Wonderful Results from Expanding Steam.

MESSRS. EDITORS.—A friend has handed me a pamphlet of 50 pages, elaborately illustrated, and said to have been extensively circulated, by a Steam Engine Company, who claim a capital of \$200,000. In this pamphlet diagrams are given of cards, said to have been taken from some of the Company's engines while at work. As shown by these cards, their engines work in absolute defiance of the known laws of forces, and the men who circulate them evince a wonderful contempt for the science of the age.

To add still more interest to these curious diagrams, they are examined, commented upon, and greatly approved of, by a "Chief Engineer," "Inspector of Steam Boilers" in a certain Congressional District, and, as the Company assures us, "one of the most thoroughly informed engineers in the country." This surely gives them respectability.

Now, if indeed this Company, with their "Chief Engineer," can set aside the laws that have heretofore governed the movement of forces—laws that the steam engine has always most obstinately refused to disregard—it is a curious fact which your readers should know, and with your permission, I will describe, for their consideration, one of these wonderful diagrams with a brief analysis.

The one I select is said to have been taken from an engine 12x24 inches, making 90 revolutions per minute.

We are not told at precisely what point the steam ports open; but as the exhaust line on the card is down near to the atmosphere until within 1½ inches of the end of stroke, and there mounts almost perpendicular so as to reach 40 pounds at the end, it is evident the port is well open at the commencement.

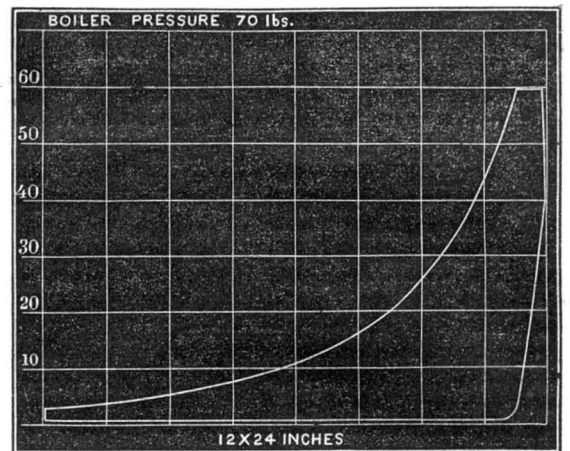

The piston has scarcely moved forward when the pressure line reaches 60 pounds; which pressure is maintained exactly uniform for just 1½ inches, where, we are informed, "the steam is cut off short" and expansion commences.

When the piston has advanced 3 inches, and the steam expanded to just twice its volume, the pressure line is still up to 42. At 4½ inches, three volumes, it is up to 32, and at six inches, having expanded to four volumes, it still maintains a pressure of 23 pounds. At the end of the stroke, when it has expanded to sixteen times its original volume, although the initiatory pressure was but 60 pounds by the gage, or 75 pounds all told, it still maintains an effective pressure of 3 pounds, or 18 pounds including atmosphere, and, as we are assured by the builders and the "Chief Engineer," it has given an average effective pressure of 17½ pounds for the whole length of the cylinder.

Now, suppose this steam at 60 pounds, or really 75 pounds pressure, to have been a perfectly non-condensing gas, and to have been allowed to expand without resistance, say in a vacuum, to 16 times its volume, the pressure would be, 75 ÷ 16 = 4.68 pounds, or about 10 pounds below the atmosphere. This is in accordance with the well-known law of the pressure and expansion of gases—a law deduced from the great principle of equilibrium which controls the movement of all forces, and is the very soul of mechanical science, and demonstrated by a thousand experiments.

Every perfectly elastic fluid, when under pressure, possesses a power exactly equal to the product of its volume and pressure. If the volume is 5 and the pressure 100, the power is 5 × 100 = 500. If allowed to expand freely until the volume is doubled, the pressure will sink to one-half and we have, as the power, 10 × 50 = 500. If it expanded to 5 times the original volume, that is, 25, it must divide out its pressure equally between these five volumes, and can, of course, give to each but one-fifth of its original pressure, 20 pounds. We then will have 25 × 20 = 500, and so we may go on expanding to 100, or 1000, volumes with the same results so long as the expansion can go on without resistance. But to assert that this gas can, by the

act of expansion, multiply the power, so that the product of its volume and pressure will be greater after expansion than before, is to assert that power can be created by merely a mechanical movement—the old dream of perpetual motion—simple absurdity.

But let us return to our diagram, and see just what our Steam Engine Company and their "Chief" do claim. Steam in cylinder before expansion, vol. 1, pres. 75; $1 \times 75 = 75$: after expansion, vol. 16, pres. 18; $16 \times 18 = 288$. These results show a multiplication of power more than three times. This is monstrous; but all is not yet told.

We are assured that the average effective pressure, that is, the work done by this steam, was $17\frac{1}{2}$ pounds for the whole length of the cylinder. However, before proceeding to inquire into this question of the work done, we must return for a moment to the law of expansion. We have seen that the mere enlargement of a perfectly elastic gas is but a division of its pressure among the several volumes into which it has expanded; the whole mass containing the same amount of force, after, as before, the expansion. Now let us inquire what is the effect when this expansion occurs under difficulties. When the expanding gas meets with opposing forces, where it must move from the path heavy obstacles, and work its way to an enlarged volume at great cost, as steam expanding behind the resisting piston; does any one claim that all this resistance is removed without cost? Can power be exerted without expending force? No more than God can be false. Then for every pound raised, or moved, by the expansive force of steam, or any other gas, it must yield an equivalent, and fall just so much below its original power.

Now as the measure of heat contained in steam, or gas, is the measure of its expansive force, and as heat and force, or motion, are equivalent, and when combined with an elastic fluid, are identical or convertible, it follows that in expending force, heat is lost. And it has been found by careful experiment that for every 772 foot-pounds of force exerted, a unit of heat—an amount of heat sufficient to raise a pound of water one degree in temperature—must be expended.

Now in the case under consideration, we are told that the effective power obtained was equal to an average pressure of $17\frac{1}{2}$ pounds for the whole length of the cylinder. The initiatory pressure of 60 pounds for $1\frac{1}{2}$ inches would make for the whole but $3\frac{3}{4}$ pounds; then there remains $13\frac{3}{4}$ pounds to be supplied by expansion. This requires a force equal to 3,107 foot-pounds. Again, the atmospheric pressure of about 15 pounds must be pushed back by the expansion, and will require a force of 3,178 foot-pounds. These together amount to 6,285 foot-pounds, equal to eight units of heat; which is necessarily withdrawn from the steam.

Let us see what this will leave. The amount of steam admitted to the cylinder is $169\frac{1}{2}$ inches, the pressure 75 pounds. Steam at this pressure has a volume of 5.7 cubic feet per pound, and a total heat of $1,175^\circ$, or units. As the steam admitted is but one fifty-eighth of a pound, it contains but twenty units of heat. We have seen that eight units have been expended in the work done; we then have but twelve left in the expanded steam. How, I ask, in the name of all the philosophers, can saturated steam, at 75 pounds pressure, expand to 16 volumes against a resistance that will cost eight-twentieths of all its heat and still maintain a pressure of 18 pounds, when a perfect gas, starting with the same pressure expanded, without resistance, or loss of heat, to 16 volumes, will sink to 4.68 pounds.

The whole thing is absurd. The days of miracles have passed. No such card was ever fairly taken from any steam engine.

E. S. WICKLIN.

Keokuk, Iowa.

[The writer of the above appears to reason and write "by book." His theory is right, but his assertion that the diagram to which he refers could not have been fairly taken from any engine, is not sustained by practice. We can show him many equally at variance with the theoretical diagram. One important point does not seem to enter into his calculation; that is what engineers call "clearance," which may be defined as all the space from the closing valve to the piston, when on the dead center, including the passage to the exhaust valve, which is a large percentage; in this case, by estimate, about one-twentieth of the whole cubical contents of the cylinder. Now the steam that fills this one-twentieth is not represented on the theoretical diagram, and hence it would have to be added to the practical, or actual diagram, and would make the terminal expansion higher, say by three pounds.

This does not, however, account for the whole of the discrepancy shown, and we must look for some additional cause. This is unfortunately, too common, and is occasioned by want of perfect workmanship. It is the leaking of the valves. This would, of course, keep the pressure of the expansion line above the theoretic line in proportion to the amount of steam admitted after the valve had closed over the port. A diagram representing the clearance, and carried below the atmospheric line would have shown, clearer than we can do by words alone, our idea. We publish our correspondent's article and his diagram, however, as they form an excellent exposition of the theory of expansion.—EDS.

For the Scientific American.

Our Sun the Origin of all the Forces on Earth.

When we trace backward the origin of all forces or motions on the surface of our planet, we come to the necessary conclusion, that they all, with the single exception of the ocean tides, are to be found in the heat of the sun. In fact, this heat causes air currents, and so the force of the wind; it evaporates the water of oceans and lakes, which, coming down on mountains as rain, forms streams, and gives water power in its descent. Again, this heat of the sun causes

plants to grow, which, storing up heat in their fibers, procure us a fuel, either fossil as coal, or recent as wood; which fuel, by its combustion, gives us only the heat of the sun back, which heat is thus made available to us at any place, at any time, and is also easily transformed into motion by means of steam or caloric engines. Or, again, the vegetable matter formed by the light and heat of the sun, is consumed by animals as food; and the stomach of animals acting in certain respects like the furnace of a steam engine, sets partially the hidden heat free to keep the animal system at the proper temperature, and partially consumes this heat to produce muscular motion for moving the individual itself, and partially this muscular motion may be applied to produce motion of matter, overcoming all kinds of resistances to this motion, and this last is what is commonly called force.

The use of a number of pounds only, as a measure of a force, without referring to its motion, notwithstanding extensively applied, is, when critically examined, very erroneous; as is also the old definition of force as something which "can create or destroy motion of matter," as if force was something exterior to matter and independent of it.

Force, on the contrary, is the manifestation to us of something co-existent with and inseparable from matter; no force without matter, and, as far as our experience goes, no matter without force.

Matter shows itself to us under different forms, and continually undergoes the most stupendous transformations by chemical and other agencies. Sometimes a light, invisible gas like hydrogen becomes condensed without any external pressure, in the one-thousandth part of its former space, in the metallic state in palladium, increasing the weight of this last metal almost one per cent; or this same gas combined with another gas, nitrogen, making the mysterious metal ammonium, forms a perfect amalgam with mercury, swelling its bulk till it becomes lighter than water, and will float on it.

Similar transformations we observe in force: one time it will manifest itself to our eyes as light streaming from the sun; then as an agent expanding matter, and giving to our bodies the sensation of heat; then changing the solidity of ice into the fluidity of water, and this again into the highly elastic vapors or steam—by every one of these molecular changes, a portion of heat disappearing, becoming latent, to reappear again when another change occurs in the opposite direction. By not only overpowering and destroying the natural cohesion of the waters molecules, but changing it in a powerful repulsion, this force increases the bulk of the water more than a thousand times, and enables it to exceed not only pressure, but to move heavy bodies; thus we may transform molecular force, or heat, into motion of the masses which then is distinctly observable to most of our senses. This constitutes what formerly, exclusively, was called a force, when heat was erroneously supposed to be some kind of imponderable fluid, having a separate existence, independent of matter.

Thus tracing back all motion on earth (always excepting the ocean tides) to the magical power of the sunbeam, the next natural question is, When is this light and heat of the sun? This question, of all-absorbing interest, I will treat in a following article.

P. H. VANDER WEYDE, M. D.

For the Scientific American.

THE TRADE IN HUMAN HAIR.

The trade in human hair has become quite important during these latter years, especially since it has been considered fashionable to replace by false hair, the deficiencies, real or supposed, of nature in this respect.

The origin of wigs is lost in antiquity; their use was abandoned during the middle ages, and was not renewed until the return of Saint Louis from the crusades, when he unfortunately became bald and was ordered by his physicians to keep his head constantly covered. Queen Blanche, his kind-hearted wife, inferring from this that it was hair that had kept her husband's head warm, obtained from all the surrounding courtiers a lock of their capillary appendages which she forthwith attached to the king's cap.

Ever since, Saint Louis has had the honor of being considered the patron saint of hair-dressers and wig-makers.

After this period wigs are not mentioned in history until the reign of King Louis XIV, who, in order to hide the unequal height of his two shoulders, wore a long wig which covered this defect. No man of quality in France was allowed to wear his own hair, and Binette, the king's wig-maker, became quite a celebrated personage who sold some specimens of his handicraft as high as one thousand dollars.

In 1674 the wig-makers as a body were duly incorporated, the members being allowed to carry side weapons, and they held the exclusive monopoly of the trade in human hair, which they retained until the revolutionary period which swept all chartered privileges from the soil of France.

Notwithstanding many eminent professors of hygiene give reasons why the wearing of false hair is not healthy, and although it is also a well-known fact that a portion of it has been cut from the bodies of the dead, still the habit of wearing other people's hair has never been discontinued since the time of Louis XIV.

Hair, to be really first quality, should be taken from the heads of the living, who have had much exposure to the air and who have never employed curling irons. The hair taken from the dead is mostly used in the preparation of watch chains, bracelets, and similar articles.

France monopolizes the largest share of the trade in human hair. Paris, Marseilles, Lyons, Caen, Guibray, and Beaucaire, are the cities which do the largest part of this trade, the last three holding annual fairs for this specialty.

In Paris alone there are some thirty or forty dealers in hair,

each of whom employs three or four regular cutters. These in their turn have several agents or decoys who visit the country, penetrating every village and hamlet through the land, where they try to induce the poor simple country girls to part with their hair for some trifling articles of barter, such as gaudy muslin handkerchiefs or false jewelry.

Some years back one firm in Paris traded in this way during one season nearly one hundred thousand dollars of merchandise; but the present merchants are compelled to pay in money instead of gewgaws. The peasants having learned the value of their hair, refuse to be swindled.

The exports of human hair, from France to the United States recently increased so rapidly that the supply proved inadequate to meet the requirements and the price was doubled. Germany, Belgium, Poland, and Russia, have since joined to furnish us with our supplies.

Another reason for the high price paid for hair is the well-ascertained fact, that, as education spreads in France, the country girls refuse to sell their hair; one of the principal motives for which is, that many of the young Frenchmen who have been drafted into the imperial army, on their liberation from service and return home, are averse to marrying the short-cropped and disfigured sweethearts they find on their return from the garrison towns, where the ladies all wear long hair, waterfalls, or chignons.

Some years back the hair-cutting agents managed to obtain a full supply from Normandy and Brittany alone; but they have now to travel over the whole of France, Italy, and Sicily. The total annual crop of the globe is at present about one million of pounds.

The northern hair is fine and soft; the southern is best fitted for curling.

Two clippings are made annually, one in the spring of the year the other in autumn, the latter being considered of inferior quality.

The collected hair is tied into separate coils and thrown loosely into sacks, which are forwarded to the merchants who must purchase or refuse the whole lot, as they are not allowed the privilege of assorting. As the hair from different portions of the same head varies in length and quality, it has to be picked and sorted by being put through six or seven successive operations, the first of which is to clear it of nits, or the adherent eggs of lice, which are abundant in the hair of the women of Italy and Brittany.

Hair destined for curling or for ringlets is rolled on small wooden rollers about four inches long, covered with paper, tightly bound, boiled, and, lastly, dried in an oven at a moderate heat. The cost of hair nearly quadruples from the time it is cut until it gets into the hands of the retailer. He in his turns attaches a quite arbitrary higher price to the same, in accordance with the presumed fortune of his customers, or the difficulty he is supposed to have experienced in finding a particular tint suited to some special taste, or to the complexion of countenance. His price may vary, for a head of hair, from two dollars to three hundred times that amount.

The art of dyeing the hair has reached such perfection in our day, that, excepting very fiery red, fair blondes, and silvery white, which are difficult to imitate, all colors sell for identical prices.

Theatrical wigs having to be seen at a distance, are cheap, with the occasional exception of the private property of some particular star actor.

It is nearly useless to add that the cast-off coils, knots, chignons, fronts, curls, and wigs are collected, cleaned, carded, and serve over and over again, spread over paddings of horse hair, or some other material, to adorn the heads of our fashionable belles.

Corn Starch—How it is Manufactured.

Methods for the preparation of this popular article of food vary somewhat with manufacturers, but the following method, patented 1854, by Mr. Polson of Paisley, Scotland, is perhaps as good as any. By this method the grain is first steeped either in alkaline water, or in water only, until the grain is thoroughly soaked. It is then reduced to pulp by the use of rollers, or other suitable machinery. It is next passed over a sieve through which the finer portions are forced by revolving brushes while the coarser parts remaining are returned to be reground. The husk or bran is thus separated, and may be used as food for cattle. A stream of water runs constantly down upon the sieve and carries the portion passing through, over an inclined plane or "run." The plane is divided into sections by wooden cleats which are laid across it. These cleats or dams intercept the starch which settles to the bottom, from which it is removed at proper intervals. The greater part of the glutinous and fibrous portions are carried along by the current, and are thus separated from the starch. The starch can be still further purified from the glutinous and fibrous matters by treating it with an alkaline solution which dissolves the gluten, running it through finer sieves, and rewashing it on the inclined plane.

FICTITIOUS GEMS.—A recent English work on diamonds says that but a small portion of the gems sold and worn is genuine. The diamond mines of Golconda have given out, and those of India are rapidly failing. Thus the scarcity of real gems has been met by the ingenuity of counterfeiters. As for these patent imitators, these indefatigable fabricators of gems, it is scarcely probable that the curious branch of industry will ever be relinquished; at least, it is certain that while poor humanity retains its present tendency to strive for that which is beyond its reach, and accept the shadow for the substance, paste diamonds, enameled porcelain opals, and pearls of fish scales will be marketable articles in the civilized world, as well as among the dusky tribes upon the coral strands of Africa.

THE MANUFACTURE OF IRON—THE RADCLIFFE PROCESS.

Attempts have been repeatedly made to economize in time, fuel, labor, and material, in the manufacture of iron, by welding several puddled balls into a homogeneous mass under the steam hammer; but never with good results. The difficulty lay apparently in securing a good weld between the surfaces, exposed as they were to the oxidation of the atmosphere. But, if we can credit *The Engineer*, Mr. Radcliffe, of the Consett Iron Works near Durham, England, has, for a year, been manufacturing, by this process, direct from the puddled ball, into bar, rail, or sheet.

In the usual process a charge of about four or five cwt. is used, and each puddled ball, when made, is taken separately to the hammer or squeezer to expel the cinder, and the rough bloom is then passed through rolls producing puddled bars. These are allowed to cool down until wanted for the next process. This consists in cutting a given weight of puddled bars into lengths of from 18 to 36 inches, and making them into a pile, which is placed in a heating furnace and raised to the proper heat, when it is rolled into a bar. This process is repeated—sometimes twice—to produce a superior article.

Now, each of these processes absorb fuel, labor, and time, and necessitate waste—waste in oxidation in the heating, as well as waste in the clippings of rough ends. The loss by oxidation cannot be less than five or six per cent, and the other waste as much, and probably more, at each re-heating. To the cost of the amount of the coal used in converting the pig iron—which is about four times the weight of the iron itself—must be added, at each re-heating, ten cwt. to each ton of iron. These costs do not comprise the extra labor, time, and wear and tear of machinery. If all these are saved by the Radcliffe process, it certainly deserves attention from iron manufacturers, as it does away with all cutting, piling, and re-heating. We copy from *The Engineer* the description of the process.

The details of the process, as carried out at Consett, may thus be described: Six, eight, or any required number of puddling furnaces are each charged with four cwt. of pig iron. The fettling consists partly of pulverized hematite ore from Ulverstone, partly of a very rich cinder obtained from the first pile heating furnaces in the rail mill, or from two furnaces specially employed in making cinder from small scrap. The iron is brought to nature as soon as possible, and the blooms are taken out while the iron is yet very young—as soon, indeed, as the balls will hold together.

The moment the iron is ready in a sufficient number of furnaces, the process of manufacture begins. A puddler takes a ball weighing about 80 lbs. to an eight-ton double-acting steam hammer. It is placed on the anvil and struck, first lightly and then, as the mass becomes consolidated, with more force. The cinder is expelled with considerable violence, and we have, at the end of twenty seconds, a flat cake of iron on the anvil perfectly quiescent. At this moment a second puddled ball is placed on the first. This receives, first a light, and then a couple of heavy blows. The hammer is raised for a few seconds, and then a curious action takes place. The first and second blows apparently expelled most of the cinder, and the mass, seemingly, tolerably solid, lies quietly on the anvil, but in a moment its surface rises like a cake of dough in a baker's oven. The surface seems to boil; little jets of flame sometimes start from the mass, and cinder pours in a torrent from every pore, flowing over the lump of iron, and running down all round. To what this peculiar action is due we cannot say. That this, in a sense, spontaneous evolution of cinder is a fact we can testify from close personal observation. A few blows from the steam hammer again consolidate the heaving mass. Another ball is placed on it; a few blows; a short pause. The rising of the mass and the flow of torrents of cinder follow as quickly as thought—and so the process is continued till eight balls are united. Then steam is brought to bear on the upper side of the hammer piston. The mass of iron is turned and re-turned, while the whole shop resounds with the sound of the hammer delivering blows with the speed of lightning on every portion of the red-hot mass, which finally assumes the form of a homogeneous slab some 3 feet long, 13 or 14 inches wide, and 8 or 9 inches thick. This slab is then taken up by a little steam crane at the side of the hammer, and, while hanging in the air, weighed. It is then run off to a heating furnace, preparatory to being rolled into a finished plate. The heating furnace is of the ordinary kind, and is only used to restore the heat lost by the outer surface of the mass. From the furnace it is taken to the roll mill, passed through the breaking-down grain rolls, and subsequently between a pair of chilled rolls in the same train, and finally it lies on the floor of the shop, a plate with whose appearance the most hypercritical can find no fault.

Mr. Radcliffe courts inquiry, and we were afforded the fullest possible opportunities for examining into the process known by his name. We witnessed the formation of many plates, and the following particulars of the manufacture of one, selected almost hap-hazard from our note-book, will show nearly at a glance of what the process is capable: At half-past three P.M. the first of eight puddled balls was brought from the furnace and placed on the anvil. In four minutes and a half this and seven other balls were welded into a slab weighing 644 lbs. At twenty-six minutes to four o'clock this pile was placed in the heating furnace; at nineteen minutes to four o'clock it was taken out and brought to the rolls; at fourteen minutes four o'clock it lay on the floor of the mill ready for shearing. Thus, precisely, sixteen minutes were occupied in producing the plate from the puddled ball. The weight of the plate before shearing was 574 lbs. It was then sheared to the finished size, 20 feet by 3 feet; thickness, 3-16th of an inch, nearly; weight sheared, 448 lbs. Is it necessary to point out here how much is gained in time, coal, iron, labor, and, finally, in money, by the Radcliffe process, as compared with old systems of manufacture? We think that they will be apparent at a glance to every ironmaster. What we have said in the beginning of this article should suffice to make them clear to others.

The question that here obtrudes itself is, what is the quality of the finished plate, bar, or rail? Unless the answer is satisfactory, the Radcliffe process—ingenious, cheap, and rapid as it is—is comparatively valueless. At Consett we examined some scores of specimens of sheets tested in every possible way. Plates 7-8 inch thick, bent cold to an angle of 90 deg. Thinner plates, bent upon themselves, coiled into a helix, split and bent backwards and forwards, dished up into troughs, twisted and tortured in every imaginable fashion, punched close to the edge

—as close as holes would go—yet no symptom of crack or flaw. We have no hesitation in classing the specimens we examined with the very best ship-plates in the market; and yet these plates are produced at a price which has enabled Mr. Radcliffe to take very heavy orders from Dutch shipbuilders, beating Belgium out of the market, and yet leaving a fair profit.

MANUFACTURE OF PRESSED AND CUT GLASS WARE.

Having described, in former articles, the composition and modes of manufacturing bottles and window glass, our readers will understand the methods employed for pressed glass ware by a very brief description. The pressed glassware is made by pressing glass into molds of iron, and the articles thus formed approximate in beauty and regularity of form to those of cut glass, described further on. The operation requires less skill in manipulation than glass-blowing, but is, nevertheless, interesting.

It will be best understood by describing the manufacture of some special article—say a fruit dish, the bowl of which is saucer-shaped, and its foot formed like the bell of a trumpet. Such an article would be made in two parts, the bowl and the foot being pressed in separate molds, and afterward joined together. A boy takes upon the end of an iron rod or "punty," a quantity of glass from the melting pot, and holds it over the open mold. The weight of the molten glass causes it to depend in the form of a large pear-shaped drop. The principal workman, who has charge of the mold, cuts off this drop with a pair of shears, as soon as, in his judgment, enough has depended to exactly fill the mold. As soon as the glass has fallen into the mold, it is closed with a lever which forces the glass into every part of the matrix. The molds are made in two parts corresponding to the convex and concave sides of the piece. So accurate is the judgment of the skilled operators in this process that they rarely fail to properly apportion the glass to the capacity of the closed mold. The glass is removed from the mold as soon as it cools enough to become rigid, and is carried by an assistant to the annealing oven, if complete; or, if, as in the particular case of the fruit dish, it requires to be joined to another portion, it is cemented to its fellow by a small portion of plastic glass, and then placed in the annealing oven. Varieties of form and pattern may be attained by this method which are impossible in the blowing process, and the larger portion of goblets, salt-cellars, and other glass table ware, in common use, is made in this manner.

The finer and most costly articles of glass ware are finished by a process called cutting, which is, however, really a grinding process, performed by means of iron, sandstone, or copper disks, of various sizes and forms, according to the nature of the work to be performed. The disks are fixed, by proper chucks, to lathes, and are supplied with sand for rough grinding, and emery for finer work. A stone wheel is also used to efface the sand marks, and wood disks are used for polishing, supplied, at first, with a mixture of pumice and rotten stone, and finally with "putty powder," a preparation of tin and lead. Flint glass is the best for this purpose, as its superior hardness enables it to take a finer polish. Great skill and artistic taste is shown by the artisans, in this department, and cut-glass wares command a higher price than any others.

Plate glass constitutes a large and important branch of the glass manufacture, and may form the subject of a future article. The numberless uses to which glass is now applied, render all information, respecting its manufacture, of value, and although the manufacture of plate glass has not yet been successfully introduced into the United States, the extent of the demand here would seem to justify further attempts at home production.

THE NORTHERN PACIFIC RAILROAD.

A joint resolution has passed both Houses of Congress relieving the Northern Pacific Railroad Company of the prohibition against mortgaging the road. This resolution was adopted in consequence of a proposition by the company to build the road without further Government aid, in consideration of the authority thus given to them.

The *Superior Gazette* says an assurance has been given on the part of the company that the road will be commenced early in the spring and pushed with a vigor worthy of so great an enterprise.

Now that the thing begins to look like work, we lay before our readers some facts showing the advantages this route possesses over that of the Union Pacific. The eastern terminus of this road is at Superior, situated at the western extremity of Lake Superior, and its western terminus is to be at the southern extremity of Puget Sound. Its length is 1,725 miles, of which the journal above quoted says:

"Not over 250 miles will have an elevation exceeding 3,000 feet above the sea, while of the Union and Central route, 1,100 miles are more than 4,000 feet above the sea, and more than 500 miles of it have an elevation of 7,500 feet above the ocean. Every 300 feet of ascent lowers the mercury one degree. The elevation of the valley of the Yellow Stone is scarcely above 2,000, while upon the same meridian the Union road reaches an elevation of 6,000 feet, and at the summit reaches 8,424, while the Northern route only attains 5,380—a difference of nearly 3,100 feet. Beside this, the fall of snow at the same elevation on the two routes is one-half less on the Northern than on the other, owing to the extreme dryness of the atmosphere.

"While a large portion of the lands granted to the Northern road is susceptible of a high state of cultivation, and of sustaining a dense population, not one acre in one hundred of the Union grant is susceptible of keeping alive more than one sage hen to the square mile.

"The Northern road will cross and drain from the north of it the country to which the United States must look for all

time to come for its supply of wheat. The country which the hardy emigrant from the north of Europe will occupy in almost countless numbers, when this road is opened. On this route he will find his 'home' climate, and as they are the better class of immigrants will add millions to the wealth of the country through which the route passes. By the time the road reaches the mountains, at least two or three hundred thousand of population would be drawn to its line; while on the Union, except at two or three isolated spots, hardly as many hundreds have an abiding place. The arable portion of the great central plain of the American continent extends twelve hundred miles to the north and northwest of the head of Lake Superior; while it does not reach over half that distance to the west of Chicago. The distance from the former to Lake Winnipeg is less than from Chicago to the Missouri river.

"The Northern route for six months in the year will not have a land carriage to exceed 1,750 miles, and from this point to the seaboard during the season of navigation, freights can be transported for one-third what railroads charge."

The latter advantage will also enable the company to do through business for a considerable portion of the year before the road is completed, by laying sections connecting the navigable waters which, for a large portion of the route, lie almost parallel to its general course.

Although this route lies so much farther north than the Union Pacific, its lower mean elevation compensates for the higher latitude in its climatic effects, and we regard it as established that there is less danger of snow obstruction than on the Union Pacific line. We have always regarded this route with favor, and are glad to see such good prospects for its speedy construction. When it is remembered that vessels coming from China make the North American coast near the straits of San Juan De Fuca, the entrance to Puget Sound, it will be seen that this road is destined to become, on its completion a formidable rival to the Union Pacific for the China trade. So far are we, however, from thinking either will ultimately suffer from competition, that we believe ere another half century shall have passed, the increase of population on the Pacific coast will necessitate the construction of a third trunk line connecting the great West with the Atlantic.

Mercury and Sulphur.

A few interesting facts, in which mercury plays a remarkable part are worth mention. Certain Dutch chemists discovered that plants cannot live in an atmosphere which contains vapor of mercury. Boussingault, of Paris, found that this noxious effect could be neutralized by introducing sulphur into the atmosphere; and further, that sulphur, when exposed to vapor of mercury, takes on a coat which resembles iron, and does not easily rub off, or soil the fingers. This coat is sulphuret of mercury. Here, therefore, is a suggestion which may be turned to account by enterprising artists. Let them melt sulphur, and cast it into statuettes, friezes, moldings, flowers, and so forth, expose them to vapor of mercury, and they will obtain a number of articles, all wearing a metallic appearance, which may be found useful for ornamental purposes. The French chemist, taking a wide view of the subject, asks whether sulphur, which is at times found in the atmosphere, may not play an important part in neutralizing the effects of noxious vapors, or the deleterious miasm which rises from marshes and the banks of rivers in hot countries. And may we not ask, whether it will ever be found possible to stay the progress of an epidemic by flooding the atmosphere with fumes of sulphur?

The Hydroscope.

An instrument called the Hydroscope has recently been invented in England, and is intended to be used for the purpose of measuring the distance of an object from a coast battery, situated at least one hundred feet above the sea level. The construction of this instrument is described as being exceedingly simple, and the apparatus, it is asserted, can be used with great ease. The hydroscope consists of a piece of ordinary gas pipe, about six feet long, to the extremities of which upright tubes are attached. The whole is filled nearly full of water, and in each upright tube is inserted a tin float, carrying a crosspiece, and weighted so that when the long tube is in a horizontal position the cross bars are on an exact level.

An upright tangent scale, graduated for yards of distance, is attached to the sight end of the tube, which moves on its center in both a horizontal and a perpendicular direction. The instrument is placed in any part of the battery which commands an open view, and the observer revolves the tube until it is in a line with the object, and then raises the tangent scale until he can just see the object in a line with the two cross bars. The range is then read off in the tangent scale, and the gun is placed in the direction thus ascertained.

WELL-DIRECTED LIBERALITY.—Mr. Peter Cooper, the founder of the Cooper Union in this city, has furnished the Trustees with the sum of \$20,000, to be applied to purchasing a complete set of mechanical models, illustrating every conceivable form in which power can be applied to machinery. The models will be procured in Darmstadt, in Germany, and will be about 2,000 in number.

PROPOSALS have been published in Berlin for the formation of a company to lay down a new telegraph line between Europe and America, to be called the International People's Cable. One part of the arrangement is, that the subscribers are to receive bonds which will be accepted in payment for the transmission of messages when the line is in working order.

Improved Steam Cooking Apparatus.

It is well known that steam is a valuable agent in the cooking of food, and it is utilized, to a great extent, not only in large establishments, where food is cooked by wholesale, but in private families. The design of the apparatus shown in the accompanying engraving, is not only to afford a means for generating steam for this purpose, but to generate it rapidly and continuously, with the expenditure of but little fuel.

The lower portion, A, is the furnace, or the compartment into which gas is introduced by the flexible pipe. The top of this department consists of a fine wire gauze, through which the gas passes and is rendered combustible by means of the oxygen of the atmosphere, that gains access through the space, B, between the gas chamber and the generator, C. The construction of this portion is peculiar. It is seen plainly near the top of the figure, where the shell is shown as broken away. The water spaces are radial, interspersed with similar radial spaces for the products of combustion, their cross-sectional area being two or three times greater than that of the water spaces. The latter communicate with a central cylindrical chamber.

It will be seen that the heat entirely envelops the water, and, passing up through the interspaces, escapes, as seen, in the direction of the arrows. The relative area of heating surface, compared with the water surface, is very great, insuring a rapid boiling, and a constant and equable heat of the fluid, notwithstanding the influx of water to supply that thrown off as steam. The water tank, or reservoir, is represented at D. This may be connected to the generator, as shown, or may be distinct and apart from it, as desired. The water passes from it to the water spaces of the generator by the pipe, E, by which the height of water in the generator is kept always at the same height as that in the reservoir. The steam is delivered to the food to be cooked through the pipe, F. The principal advantages claimed for this apparatus, are the rapidity and equability of the generation of steam for cooking purposes. The heating surface, compared with the water surface, is enormous. It is evident that gas is not absolutely necessary as a fuel, as any lamp, or even charcoal, may be employed with a slight modification of the furnace portion. The inventor has, also, other arrangements of this device, adapting it on a larger scale to the generation of steam for yielding power. Patents were issued to Job A. Davis, Nov. 3, 1868, and Feb. 2, 1869. Communications and orders should be addressed to the patentee, Watertown, N. Y.

Improved Three Wheeled Velocipede.

An objection strenuously urged by physicians against the velocipedes, now so popular, which are driven by the feet, is that the labor demanded by the lower limbs tends to produce hernia, or rupture. We question the ground for this objection, but if any exists, the vehicle shown in the accompanying engraving obviates it, being impelled wholly by the hands and arms, the feet and legs merely guiding the machine.

The front, or driving wheel, may be made of any size required, within practicable limits, that represented in the engraving being about four feet diameter, with which the inventor says he can make twenty-five miles per hour on a level. This wheel is held in the forks of an arched reach, the rear end of which is pivoted to an arched axle, the ends of which form journals for the two guiding wheels which are about two feet in diameter. The rider sits on a saddle connected to the reach by an upright sliding bar, and is sustained by a spiral spring to give ease of motion. Directly in front of the rider is an upright, through the crosspiece of which runs a shaft, having on each end hand cranks, from which rods run to corresponding cranks on the driving wheel shaft. These cranks are placed at right angles so that the machine may be put in motion from a state of rest, in whatever position the cranks may be.

Stirrups, in which the rider places his feet, are attached to cords that run to the rear axle and serve to guide the machine, as may be plainly seen. When the vehicle is to be run straight forward a spring fixed to the center bolt of the rear axle, that passes through the end of the reach, holds the axle in the proper position. This yields when pressure is brought to bear on the stirrups, but when the pressure on either stirrup is released the spring brings the axle to its normal transverse position.

The inventor states his claims of superiority of his velocipede thus: Greater speed with less labor and fatigue; a more perfect control of the machine than has been obtained by others; in going down hill the speed of the machine is entirely under the control of the rider; capable of ascending steeper inclines than can be done by other machines; cannot be easily overturned and occupies less space and is lighter than others, one that he uses sustaining three hundred

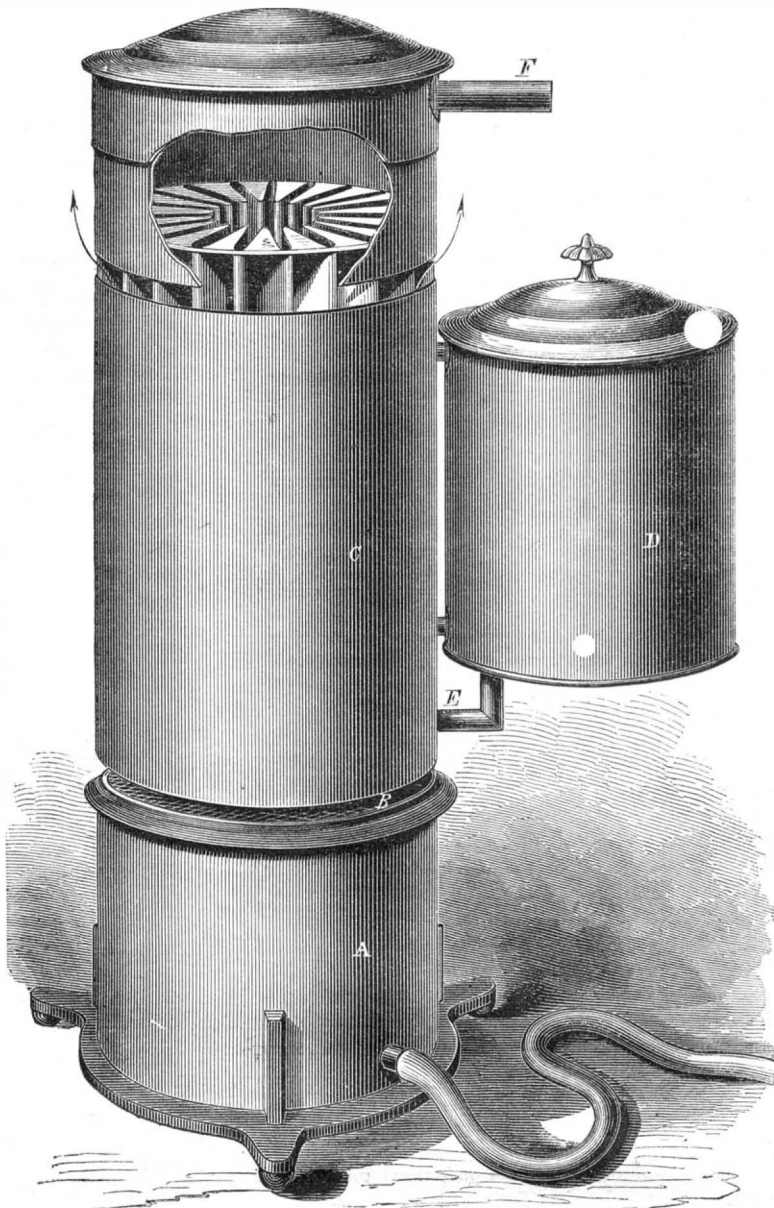
**DAVIS' PATENT CULINARY STEAM GENERATOR.**

pounds and weighing only forty pounds, although clumsily constructed. By substituting a side saddle and shortening one of the stirrups, the vehicle may be adapted for ladies' use without change of the ordinary costume, and is adapted equally well to children or grown people of either sex. The inventor also considers rubber tires preferable to those of unyielding iron. Patented through the Scientific American Pat-

**SAMUELS' PATENT HAND CRANK VELOCIPED.**

ent Agency, Feb. 23, 1869, by Isaac Samuels, of Marysville, Kansas, who may be addressed for rights, etc., as above, or Box 773 New York city.

DOUGLAS' IMPROVED PATENT GLOBE VALVE.

One of the greatest annoyances to which the occupants of buildings fitted with steam and water pipes are subjected, is the leakage of the valves. It is a well-known fact that the best fitted metallic valve will become leaky very quickly, if a particle of scale or dirt from the pipe is caught between the valve and its seat while under pressure; and a leak, however slight, will cut a channel that continually grows larger. Devices have been contrived for re-grinding valves when leaky. This, however, is attended with inconvenience. The accompanying engraving illustrates a valve that seems to obviate these difficulties.

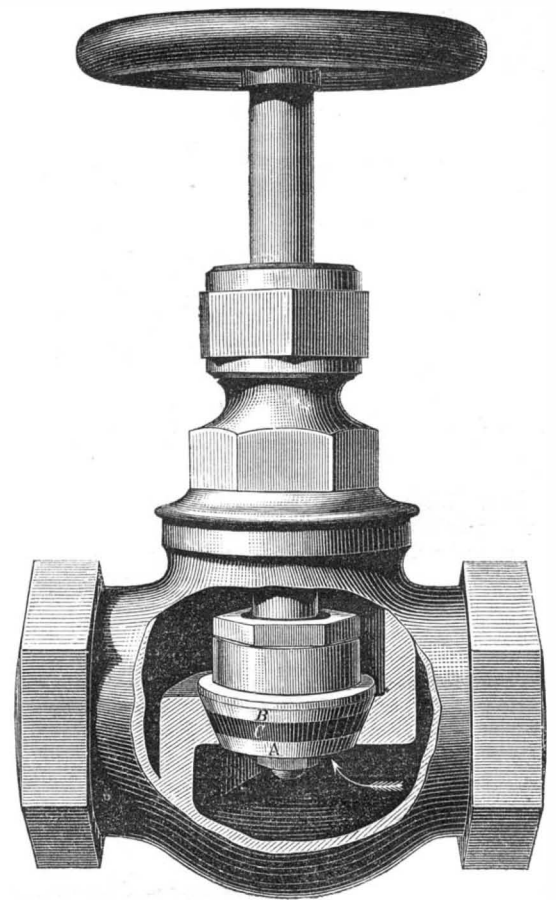

The shell is made in the usual way, but with somewhat greater depth of seat than others, the stem, stuffing-box, etc., being the same as those ordinarily used. The valve is attached loosely to the stem by ball and socket joint allowing slight play. The valve proper is composed of three parts, the lower disk, A, and the upper one, B, embracing between them a vulcanized rubber disk, C, held securely by a screw forming a part of the upper disk, and a nut, as seen. Either A or B, alone or combined, form perfect valve plugs as safe as any used on ordinary valves. In addition the flexible disk renders assurance doubly sure. The steam coming in the direction of the arrow and pressing upon the disk, A, expands this elastic disk, so that the greater the pressure the closer the fit. When worn or injured this disk may be quickly removed and another substituted. These parts are all manufactured in duplicates. This is valve adapted to steam, gas, water, and other liquids.

Patented March 17, 1868, by Frank Douglas, Norwich, Conn., who may be addressed for the right to manufacture or for the valves. They may be obtained also of Belknap & Burnham, who manufacture them at Bridgeport, Conn.

American Antiquities.

At the meeting of the American Association for the Advancement of Science, recently held in the city of Chicago, many of the papers indicated considerable activity in the researches into the antiquity and character of the early races of men who inhabited America. Col. Charles Whittlescy, in a paper on the "Geological Evidences of Man's Antiquity in the United States," maintained that four American races preceded the red man:—First, the mound-builders; second, a race in the territory now called Wisconsin; third, a warlike race in the region south of Lakes Ontario and Erie; and, fourth, a religious people in Mexico. Pottery, arrow-heads, etc., have been found in conjunction with and beneath the mastodon and megatherium. Human remains have also been found during excavations at New Orleans at a depth of sixteen feet. Mr. Foster exhibited a copper knife found in New Orleans, which he believed was a relic of the mound-builders. A water-jug, surmounted by a human head, and a statuette of a captive, with his hands bound behind him, both from Peru, and evidently of extreme antiquity, attracted much attention. It may also be mentioned, that the recent explorations of Mr. E. G. Squier, in Peru, and the curious photographs of ancient temples, dolmens, etc., which he has brought back, have renewed some old theories as to a connection in origin between the earliest inhabitants of America and those of the oriental countries.

Scientific American.

MUNN & COMPANY, Editors and Proprietors.

PUBLISHED WEEKLY AT NO. 37 PARK ROW (PARK BUILDING), NEW YORK.

O. D. MUNN. S. H. WALES. A. E. BEACH.

The American News Company, Agents, 121 Nassau street, New York. The New York News Company, 8 Spruce street. Messrs. Sampson, Low, Son & Marston, Booksellers, Crown Building 188 Fleet street, London, are the Agents to receive European subscriptions or advertisements for the SCIENTIFIC AMERICAN. Orders sent to them will be promptly attended to. A. Asher & Co., 20 Unter den Linden, Berlin, are Agents for the German States. Tubner & Co., 60 Paternoster Row, London, are also Agents to receive subscriptions.

VOL. XX., No. 13... [NEW SERIES.]... Twenty-fourth Year.

NEW YORK, SATURDAY, MARCH 27, 1869.

Contents:

(Illustrated articles are marked with an asterisk.)

Table listing various articles and their page numbers, including Lithographic Fac-simile Copying, The Manufacture of Iron, and The East River Bridge.

THE MECHANICS OF WALKING.

A discussion has commenced in regard to the asserted gain in the application of power by the use of the velocipede. One party states there is a decided gain by its use. The negative argument may be fairly put as follows: Equal bodies moving with different velocities require different powers to maintain their motion, that moving with the greater velocity requiring the greater power.

In walking the heel is first placed on the ground; the weight is next thrown on the ball of the foot, and the body is raised so as to permit the free limb to swing by the one upon which the body rests. As soon as the free limb has passed the center of gravity, the body is allowed to descend, until the heel on that side receives the weight, when the body is again raised.

Now, allowing the rate of speed attained in walking to average three miles per hour, and the length of step to average three feet, we find that the body is raised in walking 5,280 times during a walk of one hour or three miles.

According to Silliman, the power of a man when applied to the best advantage (the treadmill) is equal to 2,000,000 foot-pounds for eight hours or 4,166.6 foot-pounds per minute.

It is not to be inferred on this account, that the apparatus for locomotion provided for us by Nature is defective. On the contrary we shall find when we examine it, that it is a mar-

vel of perfection. Nature's is "nae journey wark" in any of her constructions. Direct forward propulsion is only one of the requirements of the feet and legs. They are adapted to climbing steep ascents, stairs, ladders, etc.; for descending abrupt declivities, for leaping, turning, and a variety of other movements, which wheels are incapable of performing.

It is undoubtedly true that a small portion of the power expended in raising the body while walking is converted into forward motion when it descends, and is thus utilized. It is also true that the elasticity of the limbs, stores up a portion of the power acquired in the descent of the body and applies it to the ascent of the body in each succeeding step.

The advantage possessed by the velocipede on level ground consists in the more economical application of power to direct forward propulsion, than can be obtained in walking or running, and is another illustration that a simple rotary motion is the most economical way in which power can be applied to the production of simple effects.

PRETENDED MECHANICS.

A correspondent, writing from Springfield, Mass., speaks in very harsh terms of a class of men who offer their services as those of competent machinists, yet have never served an apprenticeship and do not understand, either theoretically or practically, the business. He calls them "dead beats," a term perhaps more expressive than elegant.

The above is the "gist" of the communication the language of which we have somewhat changed, as the indignation of the writer seems to have governed his style. The statements he makes are, however, undoubtedly correct; the trade is cursed with a class of hangers-on, who, incapable of doing journeymen's work and too proud to take apprentices' position, force themselves, temporarily, into places they are unfit to fill, by simple audacious pretension.

The evil is not a small one, and the complaints of our correspondent have more foundation than a low jealousy; but it seems to us that the remedy is easily found. First, these pseudo-machinists must inevitably find their level in the shop. It is so everywhere; pretension will not always keep the leaky hulk afloat on the sea of life under the influence of the gale of experience.

Second, the impositions practiced upon foremen and employers can be prevented by themselves. Let them adopt a rule not to engage an applicant unless he can bring recommendations or certificates of competency from his former master or employer; or, in case this is impossible, as when the applicant cannot, on account of distance from his former place of employment, produce, at once, his evidences of capability, let him be taken on trial, after an examination by interrogations, and let his work be his recommendation.

THE EAST RIVER BRIDGE.

The Board of Consulting Engineers of the East River Suspension Bridge, to connect Brooklyn with New York, have lately held several meetings to consult on the plan of the proposed structure in its details, with such results as will serve to remove many of the doubts in the minds of the unprofessional and induce them to share the confidence of the Board.

The problem of a proper foundation for the towers presents the greatest difficulties. On the Brooklyn side it had been found by borings that there was a substratum of boulders which could not be disturbed by the current, and here a firm foundation could be obtained. But on the New York side the borings indicated only sand and decomposed rock, and the question was earnestly discussed whether the current of the estuary might not, in time, wash and scour out this sand, rendering the foundation of the tower insecure.

On this the tower, of heavy stone masonry, is to be erected, 300 feet high. On the Brooklyn side it is believed no timber substructure will be required, the masonry resting directly on the rock. The rigidity, sustaining power, and durability of the bridge were severally considered, and the plans submitted to secure each of these elements were unanimously adopted; the great work will, it is believed, be very soon commenced.

ALEXANDER T. STEWART---A NOBLE CHARITY.

In the last number of the SCIENTIFIC AMERICAN, we congratulated our readers upon the selection, by President Grant, of Alexander T. Stewart, of this city, to take charge of the Treasury Department. The appointment was unanimously confirmed by the Senate, but the discovery of a law made in 1729, which prevents an importer from holding the office of Secretary of the Treasury, operated to compel Mr. Stewart either to retire from business or to resign.

Mr. Stewart is about to carry into effect, in this city, his long contemplated project of erecting a home for the working women of this city, and hundreds of men are now employed in digging for the foundations on Fourth avenue, between Thirty-second and Thirty-third streets, and opposite the Harlem tunnel. The plot of ground contains twenty-two city lots, and cost \$220,000, upon which Mr. Stewart proposes to erect an iron fire-proof building 198 x 205 feet, at a cost of \$2,000,000.

CANADIAN PATENTS---HOW NOT TO GET THEM.

We have received a printed circular, addressed to American inventors, by Alexander Anderson, of Canada, wherein he states "that the Canadian Government provides that its subjects may make discoveries of inventions in any foreign country, where the subjects of that country are prohibited from obtaining patents in the usual way; the British subject making an improvement on it, and combining his improvement with the discovery, may obtain a patent. I feel confident, from my long experience in the patent business, and my inventive powers, that I can make an improvement on almost every invention taken out. I can thus obtain the patent deed and then transfer it to the inventor."

This is a very astute proposition, and is well calculated to mislead inventors who are ignorant of the exact scope of the Canadian patent system, which provides "that any person, a

subject of Her Majesty, and resident in this Province, having discovered or invented any new and useful art, machine, manufacture, or composition of matter, the same not being known or used in this province by others, may petition and obtain a patent." Another section provides that a patent shall be held to be void "on the ground that the patentee, in his specification of claims, has embraced more than that of which he was the first inventor or discoverer." This puts a complete extinguisher upon the proposition made by Anderson in his circular, and we consider it our duty to "American inventors," to warn them that a patent obtained through fraud so transparent as this, would not be worth the parchment. The Canadian patent system is a mockery of justice, and we advise "Mr. Alexander Anderson, Inventor and Patent Agent, Dominion of Canada," to stop sending out such circulars, and to turn his brilliant talents toward securing an amendment to the law of patents, such as will protect the rights of all inventors alike.

THE GAMGEE PROCESS.

Professor Gamgee's process for preserving meat, accounts of which we have heretofore published, has lately been put in operation in this city; and we recently had the pleasure of inspecting the apparatus at the establishment of the Holske Machine Co., 528 Water street. Here we found a large airtight chamber, in which a dozen or more carcasses of sheep were placed for treatment. The process consists, substantially, in submitting the meat to the action of carbonic oxide and sulphurous acid, under pressure which is maintained for several hours.

The carbonic oxide combines with the coloring matter of the blood, forming a more stable compound than when that substance is combined with oxygen—thus preserving the fresh color of the meat and assisting in preventing decomposition. But the real antiseptic agent is the sulphurous acid, which may act in two ways: First, by entering into combination with the bases of the meat to form sulphites; and, secondly, by destroying the living germs, which, according to Pasteur's theory, are the active cause of decomposition in animal and vegetable matter.

Nothing can be more complete or successful than this method of preserving meat. We tried, at home, some joints of mutton which had been treated as above, and the meat after hanging ten days or more in the air appeared to be as fresh as ever; when cooked no difference could be observed between it and the ordinary fresh meat of market. We regard it as a very important and valuable discovery.

GAS MONOPOLIES.

The Legislative Committee at Albany, continue the taking of testimony in regard to alleged abuses on the part of the gas companies. Probably a government does not exist on the face of the earth so ready to grant franchises without guarantees as that of the Empire State.

Mr. Valentine T. Hall, Secretary of the Brooklyn Gas Light Company, testified before the committee that the company is acting under special charter, dated 1826, which has been several times amended. "It contains no regulations as to price of gas, or quality we must furnish, we may charge anything we please."

Having thus obtained the privilege to lay their mains, and having got thoroughly under weigh; having at the outset a capital of \$250,000, which has increased so that it could not in the opinion of Mr. Hall, be replaced for less than \$4,000,000, with market price of stock 240 per cent when "last any was offered for sale," this unrestricted monopoly has everything in its own hands. What chance would a new company have in the attempt to compete with it? The franchise possessed by the Brooklyn Gas Light Company is so valuable that they could well afford to give away gas for two years to swamp an opposing corporation.

"Verily to him that hath, shall be given, and from him that hath not shall be taken away that which he hath:" and when this impoverished company asks for further grants from the generous New York Legislature, it will doubtless get what it wants. We have little faith that the present investigation will result in the revocation or limitation of the charter of any gas company. Such an expectation is not justified by any precedent.

BEEF ROOT SUGAR.

No. I.

In No. 4, current volume of the SCIENTIFIC AMERICAN, we expressed our belief that at some future day the United States would manufacture the whole amount of the sugar needed for home consumption, and we further stated that this sugar would, in all probability, be made from the beet.

We now think the time has come for the country to free itself, at as early a date as possible, from dangerous dependence on the foreign production of this staple, so as to avoid sudden variations in prices, and inconveniences arising therefrom, such as have actually occurred in consequence of the recent revolt in the island of Cuba.

We consider the subject of beet root sugar production in the United States to be of such vital importance to the interests of the whole community, that we have determined on publishing a series of articles, illustrated with the necessary engravings, concisely elucidating the whole question, statistically, economically, agriculturally, and technologically. This is the more necessary, as no really reliable and complete treatise on beet root sugar has ever been, to our knowledge, published in the English language.

We sincerely hope by so doing to be the means of stimulating the monied men and the agriculturists of the country into active measures, which we are fully convinced must result

advantageously, both to the public in general and to themselves in particular. Should we succeed in this object, we shall consider ourselves fully rewarded for our efforts toward its attainment.

The island of Cuba has been making about half a million of tons of sugar annually upon 1,365 estates; this quantity approximates to one-third nearly of the consumption of the world. Our refiners have been in the habit of drawing their principal supplies of raw sugar from this source, but they will soon have to look to some other, as nobody can doubt that the day of the emancipation of the Cuban slaves is fast dawning, and that a repetition here of what took place in the island of Jamaica, under similar circumstances, is to be expected, namely, a sudden falling off in the production of over eighty per cent.

Let us not be unprepared for such an emergency, which would inevitably force us into purchasing European beet root sugars at much more onerous prices than would make their home production a profitable industry.

Below we give a table exhibiting the total consumption of sugar in the United States along with the amount of foreign imports for the last eight years. This conveys to the mind a better idea of the magnitude of the sugar trade than any lengthy dissertation of ours could do. These statements are compiled from the Reports of the Chamber of Commerce of the city of New York.

Years.	Annual consumption of both foreign and native sugars in the U. S.		
	Imports of foreign sugar.	Annual consumption of foreign sugar.	Total annual consumption of both foreign and native sugars in the U. S.
	Tons.	Tons.	Tons.
1860.....	341,532	296,950	415,281
1861.....	242,908	241,420	363,819
1862.....	247,015	241,411	432,411
1863.....	243,137	231,808	284,308
1864.....	214,099	192,660	220,660
1865.....	362,243	345,809	350,809
1866.....	403,497	383,178	391,678
1867.....	555,801	378,068	400,568

From the above figures we compute that, we, as a people, are paying for sugar to foreigners, with whom we have comparatively no exchanges, a sum, which for the year 1867 alone, and at ten cents per lb., amounted to no less than \$84,687,232; a sum which, if paid yearly for ten years, with interest compounded, would be considerably more than the equivalent of one-half of our present national debt.

By manufacturing our own sugar the whole of this large amount of capital would remain in the country.

If the population of the United States, including negroes, in 1867 be estimated at 35,000,000, we find that the consumption per capita (including both races) was 28.97 lbs. per annum, an increase of 2.5 per cent over the preceding year.

The consumption of the Pacific States in 1867 was 18,000 tons. During this period 22,000 tons of maple sugar were also manufactured.

The whole production of the Southern States did not, in 1867, amount to over 5 6-10ths of the whole consumption of the country.

The average yield of Louisiana before and since the war, is interesting:

From 1822 to 1825 it averaged	30,000 hogsheads
" 1842 to 1843	140,316 "
" 1844 to 1845	204,913 "
" 1845 to 1850	211,825 "
" 1850 to 1856	276,640 "
" 1856 to 1859	287,944 "

In 1865, Louisiana made 5,000 tons of sugar; in 1866, 8,500 tons; in 1867-68, 22,500 tons, or only 20,000 hogsheads more than she had produced forty years before.

The average price of Southern sugar, from 1845 to 1850 was \$52.50 per hogshead of 1,000 lbs.; in 1853 it fell as low as \$35, and rose in 1855 to \$110.

If our average imports of cane sugar should continue to be about one billion of pounds, as at present, we have calculated that this amount could be made from the beets grown on less than 555,555 acres of good land, a quantity which we could readily spare from other crops without interfering materially with the prices of ordinary farm produce.

In order to show the extent of the beet root sugar interest in Europe, we indicate the production for the year 1867-68; it is as follows:

France.....	220,000
The Zollverein.....	165,000
Russia.....	97,500
Belgium.....	32,500
Poland and Sweden.....	15,000
Holland.....	7,500
Austria.....	92,500
	630,000

The gradual increase in production has been remarkably illustrated in France, which, in 1827, had 39 factories making 1,218,000 kilogrammes of sugar, and in 1860 had 336 making 126,180,000 kilogrammes.

The German Zollverein averaged from 1840 to 1846 about 129 factories, which made 241,487 cwt. of beet root sugar; in 1865 the production had reached 3,300,000 cwt.

Russia, in 1866-67, in the departments of Kiev, Podolia, and Volhynia manufactured 1,153,880 cwt., where, fifteen years before, not one pound had been grown.

The gradual increase in the consumption of sugar by the working classes of Europe is singularly indicative of the effects of abundance and low prices. In 1822, the consumption of sugar for every inhabitant in Germany amounted to only 1½ lb. per annum; from 1830 to 1840 it rose to 4 2-5ths; in 1848, it had reached 5½; in 1857, it was 6½, and to-day it is a little over 10 lbs.

The improvements in the manufacture of beet root sugar

have followed the increasing demand, and the gradual augmentation of internal revenue levied on it.

In 1845, the average product in raw sugar did not exceed 5 per cent of the weight of the beets; three years later it had reached 6½, and to-day it is about 8 to 8½ per cent.

The objections made by many persons to the establishment of this branch of industry on the continent are generally specious. They are comprehended in the following queries:

"Can American beet root sugar compete in price with the colonial sugars, or even with Louisiana cane sugar, and is not our labor too high to permit of any comparison being made between European manufactures and our own?"

"Are our conditions of soil and climate as suitable to the growth of the beet as they are on the other side of the Atlantic?"

"Does the beet grown in the United States contain as much sugar as it does in Europe, and can it be as readily extracted?"

In answer to the first of these questions (which we shall fully enter into with necessary figures to sustain our assertions in a future issue), we must content ourselves for the present with stating that the protective duty on foreign sugars, combined with the absence of any tax on home made beet root sugars, and the fact that good beet lands can be purchased in fee simple in America for less than one-quarter of the annual rental of such lands in Europe, are in themselves sufficient to allow us to hold our own against all outsiders.

To this may be added a peculiarity of the beet, that of leaving no waste or residue, as is the case with the cane. The beet, after all the juice has been extracted, is not merely valueless bagasse, but constitutes a most excellent material for the fattening of live stock during the winter months. Beet root molasses makes good brandy and alcohol. The residue of distillation furnishes potash. The green leaves at the time of harvesting are used as a manure, being rich in ammonia, and when dried, are largely consumed as an admixture with the lower grades of manufactured tobacco.

The production of beet sugar is well known to be one of the most remunerative investments in Europe, where the number of sugar establishments is constantly on the increase, and yet beyond what has been done by one small, but apparently prosperous German establishment in one of our Western States, not a single field of fifty acres of genuine sugar beet has ever been grown in America.

We have recently heard of a company in California who intend starting an establishment in that State within a short period of time. We wish them success, and hope that their example will be followed on the more eastern portions of the continent by some of our men of enterprise.

The beet in America, wherever it has been analyzed, and this has been done to our knowledge in the States of Illinois, Massachusetts, New Jersey, New York, and others, has never been found to contain less than 11 per cent of sugar, and has generally tested 12 per cent. Of this quantity, we extract, by our modern processes of manufacture at least, eight-tenths.

The results of numerous experiments on a scale of sufficient magnitude to be conclusive, made in the States of New Jersey, Illinois, and elsewhere, have proved that 20 tons of beets is a very ordinary crop in this country. This being the case, we may expect to make, at the rate of 8 per cent of sugar, the large quantity of 3,584 lbs. out of the 44,800 lbs. of the beet produced on one acre.

In Louisiana the average quantity of cane sugar per acre seldom reaches two hogsheads.

With the exception of the extreme North and Northwestern States, and the far South, the whole extent of the territory of the United States, wherever the soil is of the right quality, such as we shall indicate in our next article, may be made to produce the sugar beet.

Our manual labor is said to be too high; but if this be the case, may we be allowed to ask, how our producers manage to ship to European ports our flour, wheat, cotton, tobacco, and many other articles?

The secret rests with the fact that the cheapness and natural fertility of our lands, more than compensate for superior cost of labor.

We do not fear to express the opinion that Yankee beet root sugar will, at no very distant day, be offered in the markets of the world in successful competition with both colonial or European brands.

In our future articles, we shall attempt to show how this result can be attained.

Variation in our Domestic Productions.

It has been boldly maintained by some authors that the amount of variation to which our domestic productions are liable is strictly limited; but this is an assertion resting on little evidence. Whether or not the amount in any particular direction is fixed, the tendency to general variability seems unlimited. Cattle, sheep, and pigs have been domesticated and have varied from the remotest period, as shown by the researches of Rutimeyer and others, yet these animals have, within quite recent times, been improved in an unparalleled degree; and this implies continued variability of structure. Wheat, as we know from the remains found in the Swiss lake habitations, is one of the most anciently cultivated plants, yet at the present day new and better varieties occasionally arise. It may be that an ox will never be produced of larger size or finer proportions than our present animals, or a race horse fleetier than Eclipse, or a gooseberry larger than the London variety; but he would be a bold man who would assert that the extreme limit in these respects has been finally attained. With flowers and fruit it has repeatedly been asserted that perfection has been reached, but the standard has

soon been excelled. A breed of pigeons may never be produced with a beak shorter than that of the present short-faced tumbler, or with one longer than that of the English carrier, for these birds have weak constitutions and are bad breeders; but the shortness and length of the beak are the points which have been steadily improved during at least the last one hundred and fifty years; and some of the best judges deny that the goal has yet been reached. We may also reasonably suspect, from what we see in natural species of the variability of extremely modified parts, that any structure, after remaining constant during a long series of generations, would, under new and changed conditions of life, recommence its course of variability, and might again be acted on by selection. Nevertheless, as Mr. Wallace has recently remarked with much force and truth, there must be both with natural and domestic productions a limit to change in certain directions; for instance, there must be a limit to the fleetness of any terrestrial animal, as this will be determined by the friction to be overcome, the weight to be carried, and the power of contraction in the muscular fibers. The English racehorse may have reached this limit, but it already surpasses in fleetness its own wild progenitor, and all other equine species. It is not surprising, seeing the great difference between many domestic breeds, that some few naturalists have concluded that all are descended from distinct aboriginal stocks, more especially as the principle of selection has been ignored, and the high antiquity of man, as a breeder of animals, has only recently become known. Most naturalists, however, freely admit that various extremely dissimilar breeds are descended from a single stock, although they do not know much about the art of breeding, cannot show the connecting links, nor say where and when the breeds arose. Yet these same naturalists will declare with an air of philosophical caution, that they can never admit that one natural species has given birth to another until they behold all the transitional steps. But fanciers have used exactly the same language with respect to domestic breeds; thus an author of an excellent treatise says he will never allow that carrier and fantail pigeons are the descendants of the wild rock pigeon, until the transitions have "actually been observed, and can be repeated whenever man chooses to set about the task." No doubt it is difficult to realize that slight changes added up during long centuries can produce such results; but he who wishes to understand the origin of domestic breeds or natural species must overcome this difficulty.—*Darwin's Animals and Plants under Domestication.*

The Dighton Rock Inscription Disappearing.

A correspondent of the Taunton (Mass.) Gazette says the inscription on the celebrated Dighton rock, near Taunton, is slowly disappearing, owing to the effect of ice upon its surface during the winter. The solution of this singular inscription, says the writer, has given rise to much speculative inquiry, and a great diversity of opinion. It has challenged the attention of many scholars learned in antiquarian lore. Mr. Harris, the learned orientalist, thought he found the Hebrew word *melek* (king) in the inscription. Colonel Valancy considered it of Scythian origin. The Rhode Island Historical Society caused a carefully prepared drawing of the rock to be sent to the Royal Society of Antiquaries of Copenhagen, by whom it was submitted to Professor Rafn, the eminent Runic scholar, and learned associate, Professor Finn Magnusson. A part of the inscription they declared to be in the Runic character, and to read: "On this spot landed Thornfenn with one hundred and thirty-one men." Various drawings have been made of the rock and its inscription, from that of Cotton Mather to the present day, all of them differing in essential particulars; but last summer a successful attempt was made to photograph the rock with a large plate, as well as stereoscopic size, and the inscription may now be critically examined by the antiquarian.

Insulation of the Atlantic Cable.

The Boston Journal of Chemistry, asserts on the authority of a gentleman intimately connected with the working of the Atlantic Telegraph Cable that the insulation is growing monthly more perfect, and that the first cable, laid four years since, leaks less than the last one. The loss, at the present time, does not reach half of one per cent upon both cables. This is surprising, and very encouraging to the owners of the line. The extreme cold of the deep sea basin, in which the wires repose, is favorable to the retention of the electrical impulses in the channel provided for them. The time consumed in charging and discharging the conductors is a bar to rapid communication; but this is to be overcome by new methods of insulation. A device has recently been brought forward which promises to fully remove this obstacle, and thus enable submarine cables to perform double the work in the same length of time. The success of deep sea cables is now fully assured, and we may look for a large increase in the number during the next quarter of a century.

INTERNATIONAL BRIDGE OVER NIAGARA.—The special committee of the city of Buffalo, appointed to confer with the railroad companies interested in the erection of an international bridge over the Niagara river, have submitted voluminous and favorable reports. They recommend an iron bridge with stone piers and abutments, and that the city of Buffalo guarantee for fifteen years the payment of six per cent interest on \$1,250,000, on certain conditions, to be agreed to by the companies holding the charters from the respective governments. The Grand Trunk Railway obligates to pay \$50,000 annually for the privilege of passing trains over the bridge. The city council are favorably disposed, and it is thought that the terms will be agreed to.

Editorial Summary.

CEMENT FOR LEATHER.—The Coachmakers' Journal says, of the many substances lately brought very conspicuously to notice for fastening pieces of leather together, and in mending harness, joining machinery-belting, and making shoes, one of the best is made by mixing ten parts of sulphide of carbon with one of oil of turpentine, and then adding enough gutta-percha to make a tough thickly flowing liquid. One essential pre-requisite to a thorough union of the parts consists in freedom of the surfaces to be joined from grease. This may be accomplished by laying a cloth upon them and applying a hot iron for a time. The cement is then applied to both pieces, the surfaces brought in contact, and pressure applied until the joint is dry.

MATURITY OF WINES.—Dr. Dupré, lecturer on chemistry at Westminster hospital, states in a paper on wine, recently published, that pure natural wine may be considered to have arrived at maturity at the end of from five to twelve years. In that time, he remarks, the slow chemical changes which bottled wine undergoes will have produced their best effect; and after that, "the wine no longer improves by keeping, except to the taste of a few would-be connoisseurs." But there are exceptions to this rule—namely, wines unusually rich in quality, and those which are "fortified" by alcohol. Such wines continue to improve up to the end of fifteen years.

THE supposed cavities in diamonds, described by Brewster, are shown to be in reality inclosed crystals; and the conclusion arrived at, from the consideration of the whole structure of the diamond, is not opposed to its having been formed at a high temperature. The crystals inclosed in diamonds are frequently seen to be surrounded by a series of fine radiating cracks, which are proved to have been the result of the contraction suffered by the diamond in solidifying over the inclosed crystal. This explanation has been artificially verified by examining crystals formed in fused globules of borax glass, cooled slowly, when the same phenomena are seen.

INTELLIGENCE OF ANTS.—Each ant in an ant-hill knows its companions. Mr. Darwin several times carried ants from one hill to another, inhabited apparently by tens of thousands of ants; but the strangers were invariably detected and killed. Thinking that there might be a family odor by which they were recognized, he put some ants from a very large nest into a bottle strongly perfumed with asatetida, and restored them after twenty-four hours. At first they were threatened by their companions, but soon recognized, and allowed to pass.

VARNISHING PRINTS.—The following method of varnishing photographic prints is recommended by a correspondent: A piece of plate glass is heated, and, while yet warm a little wax is rubbed over it by means of a piece of cotton wool; water is then poured over the plate, and the moistened picture laid thereon and pressed closely down by means of a piece of filtering paper. When dry the picture is removed and will be found to possess a surface of the greatest brilliancy, which is not injured by the process of mounting.

A FRENCH JOURNAL publishes the following cure for hydrophobia. When a person has been bitten by a mad dog let him take seven (?) vapor baths, called Russian baths, ranging in temperature from fifty-seven to sixty-three degrees. This is the preservative treatment. When the disease shows itself let the bath be rapidly brought up to fifty-seven degrees and then slowly increased to sixty-three degrees. In the latter case one bath suffices, but the patient must carefully keep his room until he is thoroughly cured.

COCOANUT FIBER.—At a recent meeting of the Polytechnic Society of Liepsic, one of the members asserted that belting for machinery could be made of cocoanut fiber, possessing for this purpose many advantages in economy, durability, and applicability, over leather, rubber, and other substances most commonly used. How the proposed belting is to be made we have not learned.

CHIEF ENGINEER JAMES W. KING has been nominated to be Chief of the Bureau of Steam Engineering. President Grant states at the bottom of his order "in place of Isherwood whom I desire removed." It is very evident that the President means reform and we are glad to see him striking at the root of the matter.

PATENT CASE—DESULPHURIZING ORES.
BEFORE JUDGE BLATCHFORD.

The Gold and Silver Ore Separating Company vs. The United States Desulfurizing Ore Company and Melchor B. Mason.—The plaintiffs in this case were the owners of a reissued patent, No. 1,938, reissued June 6, 1855, to the Hagan Manufacturing Company and William E. Hagan, as assignees of William E. Hagan, for an improvement in furnaces for washing ores by superheated steam. The defendants were the owners of a patent issued January 3, 1865, to C. V. De Forest, Amos Howes & Co., and Geo. E. Vanderburgh as assignees of Melchor B. Mason, for an improved method of desulphurizing and oxidizing metallic ores. The plaintiffs allege in the bill in this action that Hagan was the inventor of the improvements claimed in the reissue, No. 1,938, and that said invention was identical with that covered by the defendants' patent, and they prayed that the defendants' patent should be adjudged void. The defendants answer set up that the original patent was not for the same invention as that covered by their patent, and that the reissue, No. 1,938, was procured for the purpose of fraudulently covering the inventions made and patented by Mason, and was fraudulent and void; that Hagan was not the first inventor, and that Mason was, and it prayed that the court would decree that the plaintiffs' patent was void, and the defendants' patent valid. On the argument, it was claimed by the defendants that the reissue, No. 1,938, and the defendants' patent did not claim the same thing, and were not, therefore, "interfering patents," in the sense of the thirty-sixth section of the act of July 4, 1836. Held by the Court.—That the answer does not set up that the two patents do not claim the same thing, but does allege in substance that they do cover the same thing. That independent of the admission in the answer, there can be no doubt that the two patents do cover the same invention. That the first claim of one patent is identical with the first claim of the other, and the first claim of the defendants' patent must be held to interfere with the first claim of the plaintiffs' patent. That the second claim of the defendants' patent does not interfere. That on the evidence there can be no doubt that Hagan was the first inventor of the invention claimed by him in this first claim, or that he intended to claim it in the original patent, or that the reissue, No. 1,938, is for the same invention. That the weight of the evidence is very preponderating that Mason borrowed from Hagan all that is embodied in the first claim of the patent, No. 45,803. Decree, therefore, for plaintiffs, adjudging the patent No. 45,803 to be void so far as the process therein described for removing sulphur, arsenic, phosphorus, and anti-

mony from auriferous, argentiferous, and other metallic ores, and for oxidizing the ores by treating them with hydrogen and carbonic acid gases, employs or applies superheated steam, substantially as described in the reissue, No. 1,938, and that the defendants must pay the costs. For plaintiffs, C. M. Keller; for defendants, G. Gifford.

Hagan's patent, as reissued June 6, 1865, claims

First, The employment or application of superheated steam, in the manner set forth, for the purpose of refining or reducing metals, and for the removal of sulphur, arsenic, phosphorus, or other impurities from ores or minerals.
Second, The employment or application of superheated steam, for the purpose of calcining and disintegrating quartz rock containing silver, gold, or other metals.
Third, The employment or application of superheated steam for the refining of iron, and for the converting of iron into semi or pure steel, in the manner set forth.

This invention is said to be a very valuable one, hence the decision is important to the whole mining interest.

MANUFACTURING, MINING, AND RAILROAD ITEMS.

At the Wilder Works, in East Tennessee, good iron is now being made out of raw coal and raw ore. Colonel Wilder recently said: "At the Hollidaysburg mines, in Pennsylvania, they dig 250 feet for a vein of fossiliferous ore only seven to thirteen inches thick, and here we have it above ground from three to fifteen feet thick. It costs in Pittsburgh more for the limestone than it costs us here for all the materials to make the iron."

It is reported that there are at present one hundred and seventy-eight different places in San Francisco where cigars are made, and about one thousand persons are engaged in the business. These establishments turned out 50,000,000 cigars the past year. About fifty factories are exclusively controlled by Americans, and about one hundred are managed by Chinamen. The tobacco plantations in the southern portion of the State promise heavy and fine crops this year.

An old Indian silvermine has been found in Indiana. Over one of the furnaces was found a tree that had attained a diameter of fifteen inches, showing the great antiquity of the mine. A quantity of fine metal was found at the bottom of one of the furnaces.

Since the last "shaking up" in San Francisco, the mechanics of that city have turned their attention to the contrivance of earthquake proof chimneys for the large factories. An immense iron smoke stack, forty feet high, eight feet in diameter, has just been raised upon a sugar refinery, the roof of which is sixty feet from the ground.

The Bank of California, in San Francisco, is said to employ Chinamen in half dozen gangs to count silver coins. They are said to possess marvelous skill in detecting spurious coins or those of light weight.

The land sales of the Hannibal and St. Joseph Railroad Company during the past year amounted to over million seven hundred and fifty thousand dollars.

A Pennsylvania firm have bought the Roup's Valley Iron Works, and propose to invest \$500,000 in them.

Forty whiskey distilleries in the sixth district, Kentucky, each use three hundred bushels of corn per day. The total amount used by the distilleries in the district is estimated at three million bushels per annum.

The tobacco sales at Paducah, Kentucky, during the last week were the heaviest ever known there.

The rubber works at Sandy Hook, Newtown, have received an order for a rubber belt three hundred feet long and four feet broad. If the works can turn it out, it will be the largest rubber belt ever made.

The Hoosac Valley Mills, at Pownal, Vermont, manufactured thirty-five thousand yards of cassimere during the twenty-four working days of February.

The largest single nugget ever found in any part of the world, weighing twenty-eight pounds of pure gold, was found in Cabarras county, North Carolina, in 1803.

The St. Louis Republican says, that the Iron Mountain Railroad brings into that city more car loads of freight than any road terminating there.

The new iron used on the Iron Mountain Railroad is of the T pattern with fish joints and weighs fifty-six pounds to the yard.

A machine shop in Lowell is building a lathe that will weigh seventy tons when completed.

The snow along the line of the Grand Trunk Railway, in Maine, is in many places higher than the tops of the cars.

The boot and shoe manufacture is everywhere progressing with the utmost briskness.

The snow fall in Montreal during the month of February is said to have been seventy-three inches.

Oregon has twenty-one quartz mills in operation.

Nevada has a million and a quarter mulberry trees.

Recent American and Foreign Patents.

Under this heading we shall publish weekly notes of some of the more prominent home and foreign patents.

CAR DOOR.—Thomas R. Leighton, Cameron, Mo.—This invention consists in a lower door, which is attached by hinges to the bed frame of the car, so as to open outward and downward, and thus form a short platform as part of the car.

EXTENSIVE PRUNING SHEARS.—John Stark, Thomasville, Ga.—This improvement relates to lever shears for pruning fruit and other trees, whereby the shears may be extended so as to be used as either hand or pole shears.

COOKING STOVE AND RANGE.—E. C. Little, L. E. Clow, and D. H. Nation, St. Louis, Mo.—This invention relates to improvements made in cooking stoves or cooking ranges, whereby they are made much more useful and economical than stoves or ranges of ordinary construction.

MARBLE SAWING MACHINES.—C. H. G. Pease, Danbury, Conn.—The object of this invention is to accomplish the sawing of marble and other stone in circular blocks, with a simple and effective apparatus. It consists in suspending the block to be sawn in trunnions before a horizontal reciprocating saw.

PEA RAKE.—Sylvester Skinner, Clayton, N. Y.—This invention relates to a new and useful improvement in pea rakes, and which consists in a malleable iron socket or a double ferrule welded, or otherwise joined to a curved brace or extension of the same material, which is connected to the rake head by rivets, or in other suitable manner, thus forming a suitable bend or curve, so that the handle will need no crook or bend to put the head and blade in a proper angle for cutting, and furthermore, will not loose its bend or curve as the ordinary bent wooden handles invariably do after using but a short time.

ROAD SCRAPER.—Wm. W. Rumrill, Roanoke, Ind.—This invention relates to the construction of revolving road scrapers.

MITER BOX.—John Pons, Baltimore, Md.—The object of this invention is to construct a cheap and convenient miter box, of such a nature that it can be gaged at any angle without difficulty and in a moment of time.

MACHINE FOR MAKING MOLDS AND CORES FOR CASTINGS.—William Hainsworth, Sharpville, Pa.—This invention consists in fastening the pattern in the flask in proper position, and then as the sand is filled in, raising both pattern and flask together to a considerable height and dropping them upon a solid bed, so that the concussion produced by the fall may pack the sand closely and evenly in the flask in and around the pattern.

PEA PICKER.—Abner Quinn, Wilmington, N. C.—The object of this invention is to provide for public use a cheap, simple, and effective machine, to be operated by hand or other power, by which pea nuts, or the pods of leguminous plants, can readily be separated from their vines and thoroughly cleaned 10m dirt.

FIRE KINDLER.—M. E. Ezell, Hatchechubbee, Ala.—The object of this invention is to provide for public use a simple, cheap, and convenient instrument by which a fire can be kindled in the stove, or a lamp or gas jet lighted at night without the necessity of any one's rising from bed for the purpose. By means of the same instrument the opening of a door or window may be caused to light the fire, lamp, or gas, the apparatus thereby operating as a burglar alarm.

CHURN.—Manuel Witmer, Cedar Rapids, Iowa.—This invention relates to improvements in churns, whereby it is designed to provide an improved arrangement of vibrating and swinging churns.

HINGE.—Wm. Wells, Ashtabula, Ohio.—This invention relates to improvements in hinges the object of which is to provide a locking device for spring hinges whereby the door may be held open; also an improved construction of loose jointed hinges.

COMPOUND FOR PRESERVING HAIR.—A. L. Baker, Newark, N. J.—This invention relates to an improved compound for the hair, designed to preserve it and restore its growth in cases of baldness, which will be designated "Calla Cream."

CORN CULTIVATOR.—D. C. Stover, Lanark, Ill.—This invention relates to improvements in the construction of cultivators, the object of which is to make them more useful than as at present arranged, and it consists in an improved manner of constructing the sulky or carriage and connecting the plow beams to the same.

FEEDING SHOES FOR GRINDING MILLS.—John C. Andrew, Seventy-six, Ky.—This invention relates to improvements in feeding shoes for grinding mills, the object of which is to arrange them so that they will also serve as sieves for separating chert, dirt, and other foul matter. It also consists in constructing the bottom of the shoe of any suitable reticulated substance through which the fine grains of foul matter may be separated from the good grain, and providing under the said bottom a spout for conveying it away.

STENCIL PLATES.—J. L. and H. L. Tarbox, New York city.—This invention relates to improvements in stencil plates, designed to provide a simple and convenient arrangement whereby the stencil letters may be readily connected together for forming words, and be as readily disconnected for changing their combinations without the employment of frames for holding them when set up, as is now commonly practiced.

MACHINE FOR SCRAPING AND LOADING EARTH INTO WAGONS.—Albert Ward, New Michigan, Ill.—This invention consists in suspending scrapers from the frame of a wagon between the front and hind wheels, by an adjustable apparatus, whereby the front ends of the said scrapers may be let into the earth at any required depth, which scrapers are provided at their rear ends with inclined flaps, up which the earth is forced, and delivered to a carrier operated from the hind wheels of the wagon transversely of the said wagon, and which projects from one side thereof in an elevated position, whereby the earth may be delivered to another wagon moving alongside the scraping apparatus.

BLIND FASTENING.—Wm. J. Decker, Nyack, N. Y.—This invention relates to a new combined apparatus for holding blinds and shutters closed, open, or partly open, for locking them safely to the window frame and sash and or setting the slats. The apparatus is of very simple construction, readily applied to old and new blinds and not liable to get out of order.

FISHING NET.—F. A. Werdmuller, New York city.—This invention relates to a new apparatus for catching fish, crabs, lobsters, and other animals in deep water, and consists of a rigid frame, which forms the upper edge of a shallow bag, and the outer support for a flat ring, both the bag and ring being woven in suitable material. When this net is let into the water, and some bait placed into it, it will form a secure trap for the animals entering it, as the same cannot escape except by direct upward motion, which is scarcely ever attempted, and which is made impossible when the net is being drawn up.

WASHING MACHINE.—H. B. Tibbits, Vineland, N. J.—This invention relates to a new machine for washing clothes; and it consists in the application of a rubber and box bottom of peculiar form and construction, whereby when the requisite motion is imparted to the rubber, a combined rubbing and striking action is produced. The lower face of the rubber is V-shaped and corrugated or roughened. The bottom of the suds box is also V-shaped and roughened or corrugated. The rubber working on it will be drawn from one inclined face of the bottom to the other, and will rub the clothes as it travels on each face, striking or pounding them as it reaches the end of a stroke. The invention also consists in providing a device for supporting the rubber above the box, to allow garments to be put in or removed from the box.

TOY BALL EJECTOR.—E. S. Belton, New Orleans, La.—This invention relates to an improved toy for amusement of children and others, and it consists of a cup or mortar, having a handle for holding the mouth of the cup upward, in which a piston is arranged for suddenly ejecting a ball from the cup into the air.

WATER WHEEL.—D. Holdiman & S. Goodwin, Waterloo, Iowa.—The object of this invention is to provide an improved water wheel of the turbine class. It consists of a horizontal wheel, having the buckets arranged to be acted upon by the direct action of the water, and also by the reaction of the same, having a contracted discharge tube to produce an effect by suction, and a series of adjustable gates arranged to act as expansible sheets to convey the water to the wheel; also an improved arrangement of means for actuating the said gates. The buckets are so constructed as to discharge a portion of the water sidewise toward the center of the same, and another portion downward through the bottom.

TRITURATING AND AMALGAMATING APPARATUS.—Leonard Wray, Ramsgate, England.—This invention of improved methods of, and apparatus for obtaining or separating metals from their ores, matrices, slimes, tailings, or other substances containing them, is applicable to those kinds of minerals, earths, clays, sands, gravels, or conglomerates which contain gold or silver in any form, shape, or combination, and which may or may not require to be pulverized, washed, concentrated, triturated, or amalgamated in order to facilitate the great object of separating and obtaining the precious metals existing in these substances by washing, as in the case of tin, and some other of the refractory minerals, such as auriferous and argentiferous pyrites, sulphides, sulphurets, antimonates, or other combinations containing gold or silver, or by direct amalgamation, as in the case of the precious metals. This improved apparatus for effecting these objects consists of a machine which has for its object to triturate the ore or substance containing the metal until it is reduced to an almost impalpable powder; and secondly, of a machine for washing the mineral matters, and for catching or securing by amalgamation the precious metals, even to those finest particles which, in ordinary processes, float away with the water, and are lost.

BRAD REELS AND GUIDES FOR SEWING MACHINES.—William Carpenter, Fairbury, Ill.—The nature of my improvements relates to the application to sewing machines of a means for supplying braid to be sewed on to the cloth, and for guiding the same in a more perfect and satisfactory manner than can be done by the means now in use; and it consists in attaching to the frame of the machine a braid reel in a position above the work so as not to obstruct or be in the way of the same, and arranging it in combination with guides on a braid foot of peculiar construction, whereby a braid of any width may be easily and truly guided to the needle so as to be sewed to the cloth in the middle, or on either edge, as may be desired, and whereby the angles may be made much more perfect than by the means now in use.

FENCES.—Joseph B. Tedrow, Chillicothe, Ohio.—This invention relates to improvements in fences, the object of which is to render them cheaper of construction, more durable, and to arrange them so that they may be protected from floods when located in river bottoms subject to be overflowed. It consists in providing sectional posts, to be constructed partly or wholly of metal, and joining the sections, either by bringing them together or driving the one into the socketed end of the other. They are also constructed sometimes wholly of metal, and in one piece.

SOLDERING APPARATUS.—Chas. Pratt, New York city, and Conrad Seimel, Greenpoint, N. Y.—This invention relates to an apparatus intended for holding sheet-metal vessels and cans which are to be soldered at their edges; the part of such apparatus holding the same being made adjustable, so that the can or vessel can be immersed in the solder to the requisite depth and be raised out, when soldered, in a straight line, thus preventing the unequal distribution of solder occasioned by careless handling. The invention consists chiefly in retaining the can or box to be soldered, in a proper position by means of a frame or float, which can be depressed and elevated at will, to allow of the can or box being uniformly immersed in and raised out of the solder to the extent required.

CULTIVATOR PLOW.—William Looker, Graham, Mo.—This invention has for its object to furnish an improved cultivator plow, simple in construction, effective in operation, and easily operated, each of the plows operating independently of the others.

CAR AXLE.—E. T. Ligon, Demopolis, Ala.—This invention has for its object to improve the construction of car axles, so as to make them stronger, less liable to break, and less liable to fall or part suddenly when injured, or when there may be a flaw in the metal.

STIRRUP STRAP LOOPS.—A. B. Zellner, Monticello, Ark.—This invention has for its object to furnish an improved stirrup-strap loop, which shall be so constructed and arranged, that, should the rider be thrown or fall from the horse, the stirrup strap may be disengaged from the loop, so as to guard against the person's being dragged by the foot, should it accidentally become caught in the stirrup.

HOEING MACHINE.—Horace C. Briggs, West Auburn, Me.—This invention has for its object to improve the construction of the improved hoeing machine, patented by the same inventor, Nov. 17, 1868, and numbered 84,165, so as to make it more convenient and effective in use.

SKYLIGHT AND VENTILATOR.—George Hayes, New York city.—This invention relates to a new and improved method of constructing and arranging skylights and ventilators on dwelling houses and other buildings; and it consists in securing the glass of the skylight, in a metallic frame without the use of putty or other equivalent material, and arranging it so that all leakage is avoided, and in the method of operating a series of skylights or ventilators, either in a cluster or range.

Answers to Correspondents.

CORRESPONDENTS who expect to receive answers to their letters must, in all cases, sign their names. We have a right to know those who seek information from us; beside, as sometimes happens, we may prefer to address correspondents by mail.

SPECIAL NOTE.—This column is designed for the general interest and instruction of our readers, not for gratuitous replies to questions of a purely business or personal nature. We will publish such inquiries, however, when paid for as advertisements at \$3.00 a line, under the head of "Business and Personal."

All reference to back numbers should be by volume and page.

G. W. K., of D. C.—We have seen tolerably good specimens of American Russia-sheet iron, but nothing equal to the imported.

C. A. S., of —Gasoline is so exceedingly volatile that its evaporation can be prevented only by keeping it in hermetically sealed vessels, of non-porous material. You will find answers to your other inquiries in any elementary text-book on chemistry.

J. T., of N. Y.—No substance known can be positively asserted to be a simple substance or element. The possibility of discovering elements in the base metals, which will unite to form the precious metals, of course implies the recombination of those elements to form the base metals.

E. M. S., of La.—A splendid blue writing fluid can be made as follows: Take pure Prussian blue six parts, and oxalic acid one part, mix with a little water and rub it into a perfectly smooth paste. Then dilute with rain water to the proper consistency, and add a little gum-arabic to prevent the spreading of the ink.

R. R., of Ohio, writes us that in the discussion relative to the floating of solid on melted iron, the fact that white or chilled iron will sink and gray iron will float has not been mentioned. Reference to this statement may serve to throw some light upon the discrepancies in experiments as hitherto recorded. We would inform this correspondent in reply to his inquiry that, red hot iron has as high a temperature as the flame generated in the combustion of many substances.

H. and Co., of W. Va.—The "proper speed of a mule saw to cut the most lumber" depends on the quality of that lumber. It will vary according to this circumstance from 200 to 300 revolutions, or double strokes per minute. The proper speed of a circular saw is 9,000 feet per minute for the edge; thus in case of your 54-inch circular saw it would be: 14 feet, the circumference, 9,000 feet, the speed, product by division 648, the number of revolutions. If the lumber is soft wood and clear 700, or even 720 revolutions may be advantageously used.

J. H., of N. J., can bronze his gun barrel by diluting either nitric or sulphuric acid with its volume of water and applying it to the barrel with a rag. Be sure the barrel is perfectly clean. This cleanliness can be assured by washing the barrel with lye or soap suds and rubbing dry with cocoonut husk. Several applications of the acid may be required, but one is usually enough. When the tint is obtained wipe off with an oily rag.

U. E., of N. J.—We do not approve of leading the exhaust steam into a brick chimney stack, as it tends to disintegrate the mortar. It will, however, increase the draft. Better build the chimney higher.

B. H., of Mich.—We have already given detailed descriptions, generally illustrated, of all the notable improved firearms in this country and Europe. They are to be found in back volumes from XIV. up. The galvanic or electro-magnetic battery is fully described in almost any work on chemistry or natural philosophy.

W. W. T., of R. I., says he has a gear of 100 teeth, pitch 18 to the inch, what thread shall he cut on a worm to drive it? If the gear teeth are 18 to the inch, of course the worm must be the same pitch—18. one revolution of the worm moves the gear the space of one tooth.

J. N. H., of Canada, asks where the best smoke consuming apparatus, the best paint and putty mill, and the fixtures for using liquid fuel may be obtained.

D. W. H., of Iowa.—Your explanation of the inside and outside crank pins in reply to the inquiry on page 151, current volume, SCIENTIFIC AMERICAN, is correct, but altogether unnecessary.

A. B., of Tenn.—We cannot understand how you can use the condensed steam for a blast or draft after heating your feed water with it. Condensed steam is water. The capacity of a boiler is increased by heating the feed water—we mean the capacity for producing a given amount of steam in a given time. A pipe one-and-a-fourth inches diameter is sufficient to supply a steam cylinder six inches unless the pipe is very long, crooked, and unfelted.

J. W. H., of Minn., asks if a belt running at a speed of 2,400 feet per minute will transmit more power than the same belt running 1,600 feet per minute. Of course it must; it requires more power to drive it at the greater velocity and that power is not thrown away. Velocity is one of the manifestations, if not an element, of power.

C. H. P., of Ill.—We have lately published recipes on cements and mullages. The bases of them are starch, gum-arabic, dextrine, or gum tragacanth, dissolved in water and preserved by a small addition of alcohol or acid.

E. E. P., of N. Y.—The occurrence of a partial or complete explosion in a kerosene lamp upon the slight turning down of the wick, may be accounted for by supposing the heat to have generated gas in the lamp,

which could not readily escape, until the turning of the screw opened some small aperture. This view is sustained by the sound you describe as of escaping steam. If the wick was drawn in tight, when saturated with oil it would prevent the escape of the gas, until lowered. The orifices by the side of the burners you describe might easily become stopped by concentered oil. The best kerosene oil will be converted into gas by heat.

J. B., of Pa.—This correspondent asks how many horse powers are required to drive an eight or ten inch circular saw, running entirely in wood. He says he runs an eight inch saw through one inch board, turning with one hand. The question is indefinite. The speed of the saw, its thickness, whether ripping or cross-cut, the sort of wood sawed, etc., should be known before a definite reply could be made.

M. E. H., of Iowa, says he has laid 4,000 feet of two-inch pipe from a spring which is 80 feet higher than the delivery end, but the water rises at that point only 15 feet. The pipe runs in a straight line, having a descent of 18 feet the first 1,000, the remainder level to the upright delivery. In this case there can be no reason why the water will not rise to the level of the head, less the friction, which, however could not retard the water to the amount of 15 feet. The pipe has a leak somewhere in its length.

H. M. S., of Ohio.—We do not remember one instance in which Congress has ever been asked to repeal a patent. It is not likely that any such application would be acted upon, unless very special reasons could be shown.

Business and Personal.

The Charge for Insertion under this head is One Dollar a Line. If the Notices exceed Four Lines, One Dollar and a Half per line will be charged.

Velocipede Wheels—10,000—Superior to all others. Send for an illustrated circular and price list. G. F. Perkins & Co., Holyoke, Mass.

To watchmakers and dealers in watches—Wanted, agents in every City, County, & State in America, and all parts of the globe for Arthur Wadsworth's patents. Apply to Patentee, Watch Factory, Newark, N. J.

Manufacturers of coil and other heaters for steam boilers send circular and price list to Reading Hardware Works, Reading, Pa.

Portable engine, 10-h. p., 2-hand. A bargain. Agents for Hoagland's patent lock valve. Address Handel Moore & Co., 5 Pine st.

Just patented—Cheapest and best water meter. Apply to Hamilton E. Towle, 78 Cedar st., New York

Letter-copying Brush—water in handle, enough to make 100 copies. Liberal terms to the trade and to canvassers. T. Shriver & Co. No. 1 Spruce st., New York.

Lillingston Paint, pure white, mixed ready for use. The best, cheapest, most durable and convenient paint ever made. All you have to do is to pour it out and go to work with your brush. All the colors and varnishes mix with it. Address Lillingston Paint Co., 530 Water st., N. Y.

Velocipedes cheap.—Specifications and elaborate drawings, by the aid of which any mechanic may construct a velociped, together with full instructions for learning to ride, sent for fifty cents. Address M. M. Roberts, Box 3481, Boston Postoffice.

Wanted—Superior spring steel, Solingen preferred, 1-8 of an inch thick, 2 1/2 or 3 feet long. Also, wanted, the address of manufacturers and dealers or horse powers and threshers. John H. Hafner, Commerce, Mo.

Etching on saw blades—A cheap and rapid process wanted, to take the place of stamping name, etc. Must be small and neat throughout, and duplicate of each other. Woodrugh & McParlin, Cincinnati, Ohio.

Inventors' and Manufacturers' Gazette—a journal of new inventions and manufactures. Profusely illustrated. March No. out. \$1 per year. Sample copies sent. Address Sattiel & Co., Postoffice box 448, or 87 Park Row, New York City.

H. C. Sandusky & Co., General Agents for the sale of patents. Rights, territory, and patented articles sold on commission, 12 Mill st. opposite Postoffice, Lexington, Ky.

Peck's patent drop press. For circulars, address the sole manufacturers, Milo Peck & Co., New Haven, Ct.

The manufacture of sheet and cast metal small wares is made a specialty by J. H. White, Newark, N. J.

The Magic Comb will color gray hair a permanent black or brown. Sent by mail for \$1.25. Address Wm. Patton, Treasurer Magic Comb Co., Springfield, Mass.

For coppered iron castings address J. H. White, Newark, N. J.

Patent right agents please address Box 230, New Britain, Conn., for description of valuable patent for sale on commission.

For portable grind mills and mill machinery, address J. T. Phillips, No. 13 Adams st., Brooklyn, N. Y.

For sale at a bargain—a complete barrel factory, nearly new. Address Hartmann, Laist & Co., Cincinnati, Ohio.

Diamonds or Carbon for mill-stone dressing, drilling, and all mechanical purposes. Also, Glaziers' Diamonds. See advertisement on another page.

Brick clay lands for sale. Apply 19 Cliff st., New York, Room 7.

Pickering's Velocipede, 144 Greene st., New York.

Two-set knitting mill for sale—See advertisement back page.

W. J. T.—We think the patent asbestos roofing manufactured by H. W. Johns, of this city, is the best substitute for tin or slate. It is cheap and easily applied.

Tempered steel spiral springs. John Chatillon, 91 and 93 Cliff st., New York.

For solid wrought-iron beams, etc., see advertisement. Address Union Iron Mills, Pittsburgh, Pa., for lithograph, etc.

Punching and shearing machines. Doty Manufacturing Co., Janesville, Wis.

Responsible and practical engineers pronounce the Tupper Grate Bar the best in use. Send for a pamphlet. L. B. Tupper, 120 West st., N. Y.

Iron.—W. D. McGowan, iron broker, 73 Water st., Pittsburgh, Pa.

N. C. Stiles' pat. punching and drop presses, Middletown, Ct.

Machinists, boiler makers, tilters, and workers of sheet metals read advertisement of Parker Brothers' Power Presses.

Winans' boiler powder, N. Y., removes and prevents incrustations without injury or foaming; 12 years in use. Beware of imitations.

The paper that meets the eye of all the leading manufacturers throughout the United States—The Boston Bulletin. \$4 a year

Official List of Patents.

Issued by the United States Patent Office.

FOR THE WEEK ENDING MARCH 9, 1869.

Reported Officially for the Scientific American.

SCHEDULE OF PATENT OFFICE FEES:

Table with 2 columns: Description of fee (e.g., On each caveat, On filing each application for a Patent) and Amount (e.g., \$10, \$15, \$50).

In addition to which there are some small revenue-stamp taxes. Residents of Canada and Nova Scotia pay \$500 on application.

Patents and Patent Claims.—The number of patents issued weekly having become so great, with a probability of a continual increase, has decided us to publish, in future, other and more interesting matter in place of the Claims. The Claims have occupied from three to four pages a week, and are believed to be of interest to only a comparative few of our readers.

Patent Solicitors, No. 37 Park Row, New York

- 87,532.—RAILROAD CAR HEATER.—William H. Beal, Philadelphia, Pa. Antedated Nov. 16, 1868.
87,533.—PLOW.—James F. Benton, Penn Yan, N. Y.
87,534.—FEATHER RENOVATOR.—Lafayette Blair, Painesville, Ohio.
87,535.—COTTON GIN.—John B. Brackett and Wyman Dearborn, Boston, Mass. Antedated March 2, 1869.
87,536.—POTATO DIGGER.—John I. Brinkerhoff, Auburn, N.Y.
87,537.—APPARATUS FOR CONTINUOUS DISTILLATION.—Chas. H. Budd, Philadelphia, assignor to himself, and G. D. Wolf, Norristown, Pa. Antedated Feb. 26, 1869.
87,538.—STEAM-ENGINE ROTARY VALVE.—A. R. Buffington, United States Army.
87,539.—MOWING MACHINE.—George E. Burt, Harvard, Mass.
87,540.—THRESHER AND SEPARATOR.—John W. Cardwell, Richmond, Va., assignor to himself and Samuel Freedley.
87,541.—COTTON BALE TIE.—John S. Carson, Brookhaven, Miss.
87,542.—GRAVEL SPREADER.—John S. Casement, Cleveland, Ohio, and John Elliott, Erie, Pa.
87,543.—PORTABLE HEAD REST.—H. E. Churchill, Portland, Me.
87,544.—FIRE EXTINGUISHER.—George Clark, Jr., Boston, Mass.
87,545.—APPARATUS FOR PASTING AND HANGING WALL PAPER.—A. H. Clay, Pottsgrove township, Pa.
87,546.—MACHINE FOR THREADING SCREWS.—J. A. Cleaveland, Logansport, Ind.
87,547.—WRENCH.—Loring Coes, Worcester, Mass.
87,548.—ANIMAL TRAP.—Henry H. Cottrill, Vinton Station, Ohio.
87,549.—CATCH FOR CARPET-BAGS.—George Crouch, New York city.
87,550.—DIRECT ACTING STEAM-ENGINE.—G. H. Deane, C. P. Deane, and J. B. Gardiner, Springfield, Mass. Antedated Dec. 21, 1868.
87,551.—REVOLVING FRAME FOR SHOWING GOODS.—Thomas Dickinson, Jr. (assignor to himself and Thomas Dickinson), Buffalo, N. Y.
87,552.—MACHINE FOR MARKING CORN GROUND, WITH RAKE ATTACHMENT.—Morris Dickie, and E. P. Cowan, Ottumwa, Iowa.
87,553.—FINGERED SCOOP.—Harrison Doolittle, East Cleveland, Ohio.
87,554.—HOSE COUPLING.—Jacob Edson (assignor to John Clark), Boston, Mass.
87,555.—ROTARY WIRE FEED.—Wm. A. Foskett, Meriden, Conn.
87,556.—GAS APPARATUS.—Wm. Foster, Jr., and G. P. Ganser, New York city.
87,557.—MACHINE FOR MANUFACTURE OF WIRE STRIPS.—T. Fowler, Seymour, Conn.
87,558.—FENCE.—Melvin J. Gaskill, Pleasant Plain, Ohio.
87,559.—SEWING MACHINE FOR MAKING SHIRT BOSOMS.—E. D. Gird, Cedar Lake, N. Y.
87,560.—REGISTER FRAME.—Bartholomew Gommenginger, and Chas. W. Trotter, Rochester, N. Y.
87,561.—HARVESTER.—A. B. Graham, Waukegan, Ill.
87,562.—MODE OF PRESERVING EGGS.—J. H. Hall, New York city. Antedated March 3, 1869.
87,563.—BUCKLE.—Martin Haneline, Huntington, Ind. Antedated Feb. 27, 1869.
87,564.—GRATE BAR.—Michael Helbling (assignor to himself and John F. McKinney), Allegheny City, Pa.
87,565.—HORSESHOE.—John A. Heyl (assignor to himself and J. H. Wiggins), Boston, Mass.
87,566.—BRIDGE FOR PLAYING POOL.—O. A. Hill, Westbrook, Me.
87,567.—APP RATUS FOR HEATING WATER BY STEAM.—H. S. Huidekoper, Meadsville, Pa.
87,568.—FIREPROOF GRAIN BIN.—George H. Johnson, Buffalo, N. Y.
87,569.—BRACING FOR CYLINDRICAL STRUCTURES.—Geo. H. Johnson, Buffalo, N. Y.
87,570.—COFFIN BIER.—Patrick Joyce, Rochester, N. Y.
87,571.—AXLE SET.—H. R. Ladd, Orwell, Ohio.
87,572.—SUBSTITUTE FOR TOBACCO.—J. C. Lange, Pittsburgh, Pa.
87,573.—MACHINE FOR GRATING FODDER.—Jason Lusk, Freonia, Mich.
87,574.—DINNER PAIL.—Alfred McQueen, Philadelphia, Pa.
87,575.—REGULATOR FOR GAS, STEAM, AND OTHER FLUIDS.—E. C. Mardant, Paris, France, assignor to Marius Caune, Crawford, N. J.
87,576.—SEED SOWER.—F. H. Manny, Rockford, Ill.
87,577.—HARROW.—N. B. Marsh (assignor to himself and I. R. Miller), Marengo, Ill.
87,578.—PUDDLING AND OTHER FURNACES.—Hugh McDonald (assignor to himself, and Wm. Stuart), Pittsburgh, Pa.
87,579.—VELOCIPEDE.—Wm. McKeeran, Pittsburgh, Pa.
87,580.—WAGON AXLE.—F. McManus, Ellenburg Center, N. Y. Antedated Feb. 27, 1869.
87,581.—MACHINE FOR FIGURING CARPENTERS' SQUARES, ETC.—Norman Millington (assignor to Eagle Square Company), South Shaftsbury, Vt.
87,582.—CAR COUPLING.—Henry T. Moody, Newburyport, Mass.
87,583.—COMBINED PEN AND PENCIL HOLDER AND KNIFE.—Wm. A. Morse, Philadelphia, Pa.
87,584.—WORK BENCH.—H. W. Neary (assignor to himself and Nathaniel Schenck), Princeton, N. J.
87,585.—TURBINE WATER WHEEL.—Jesse Newlin, Philadelphia, Pa.
87,586.—DOVETAILING MACHINE.—Charles Ohlemacher and Otto Kromer, Sandusky, Ohio.
87,587.—REGISTER POINT FOR PRINTING PRESSES.—Andrew Overend, Philadelphia, Pa. assignor to Richard M. Hoe, New York city.
87,588.—BRANDING IRON.—Frank L. Penney, Boston, Mass.
87,589.—CANOPY, OR MOSQUITO BAR.—Jacob B. Platt, Augusta, Ga.

- 87,590.—LAST.—Micah H. Pool, East Abington, Mass.
87,591.—PORTABLE MAP HOLDER.—George Rice, Framingham, Mass.
87,592.—TUBE WELL.—Reuben Rich, Dorchester, Mass.
87,593.—CARTRIDGE-MAKING MACHINE.—Benjamin S. Roberts, United States Army.
87,594.—PLOW AND SUBSOILER.—Gain Robinson, Plymouth, Ohio.
87,595.—SEWING MACHINE.—Daniel H. Rogan (assignor to himself and Cyrus L. Hall), Hudson, Wis.
87,596.—VELOCIPEDE.—M. B. Stafford, New York city.
87,597.—FARM FENCE.—John K. Staman, Mansfield, Ohio.
87,598.—PAPER FILE.—Anson P. Stephens (assignor to himself and Benjamin F. Stephens), Brooklyn, N. Y.
87,599.—MANUFACTURE OF SPIRITS.—George B. Stone, Chicago, Ill.
87,600.—FARM GATE.—John G. Talbot, Sloansville, N. Y.
87,601.—LAMP BURNER.—Alexis Thirault, Brooklyn, N. Y., assignor to Holmes, Booth, and Haydens, Waterbury, Conn.
87,602.—STRAW CUTTER.—Edward R. Thompson, Lansing, Mich.
87,603.—INHALER AND REMEDY FOR THROAT DISEASE.—Geo. Humphrey Tichenor, Canton, Miss.
87,604.—SOLDERING IRON.—William H. Trissler, Cleveland, Ohio.
87,605.—MEDICAL COMPOUND.—Philip W. Vaughan, Columbia, Ky.
87,606.—HARNESS SADDLE.—John White, Palmer, Mass.
87,607.—STARCH OR GLOSS FOR USE IN LAUNDRIES.—Peter W. Weida, Philadelphia, Pa.
87,608.—PAPER-BAG MACHINERY.—Joseph Wells (assignor to Orlando A. Wilcox), Brooklyn, N. Y.
87,609.—CARRIAGE AXLE.—John T. Wilson (assignor to himself and Coleman, Rahm & Co.), Pittsburgh, Pa.
87,610.—HOT-AIR FURNACE.—Isaac T. Winchester, Boston, Mass.
87,611.—MEAT CUTTER.—O. B. Woodruff, Southington, Conn.
87,612.—EQUALIZER.—G. W. N. Yost, Cory, Pa.
87,613.—GRAIN DRYER.—Edson A. Abbott, Baltimore, Md.
87,614.—BLACKING BRUSH.—Robert Adams, Cincinnati, Ohio. Antedated February 26, 1869.
87,615.—FEEDING SHOE FOR GRINDING MILLS.—John C. Andrew, Seventy-six, Ky.
87,616.—LOOM FOR OPERATING SHUTTLE BOXES.—John Ashworth (assignor to George L. Davis, John A. Wiley, and Joseph M. Stone), North Andover, Mass.
87,617.—WASHING MACHINE.—T. Bailey and Virgil W. Blanchard, Bridport, Vt.
87,618.—COMPOUND FOR RENEWING HAIR.—A. L. Baker, Newark, N. J.
87,619.—PAD AND LINING FOR HORSE COLLARS.—Seth W. Baker, Providence, R. I. Antedated March 4, 1869.
87,620.—MACHINE FOR TWISTING BULLION FRINGE.—Edwin Barton, Paterson, N. J.
87,621.—TOY.—E. S. Belton, New Orleans, La.
87,622.—CAR COUPLING.—Benjamin Bevelander, Boston, Mass.
87,623.—PINION.—V. W. Blanchard, Bridport, Vt.
87,624.—ARTIFICIAL LEG.—Douglas Bly, Macon, Ga.
87,625.—EXTERIOR CASING FOR TURBINE WATER WHEELS.—John W. Bookwater, Springfield, Ohio.
87,626.—GLASS BOARD AND APPARATUS FOR CUTTING GLASS.—Franklin Bowly, Winchester, Va.
87,627.—HOEING MACHING.—Horace C. Briggs, West Auburn, Me.
87,628.—WIND WHEEL.—A. P. Brown, Syracuse, N. Y.
87,629.—GRATE FENDER.—George Buchanan, Washington, Pa.
87,630.—VELOCIPEDE.—Jabez Burns, New York city.
87,631.—FLY-NET FOR HORSES.—Joseph Cantner, Millheim, Pa. Antedated February 27, 1869.
87,632.—CUTTING THREADS ON PIPES, ETC.—J. M. Carpenter, Florence, Mass.
87,633.—EMBROIDERING ATTACHMENT FOR SEWING MACHINES.—William Carpenter, Fairbury, Ill.
87,634.—GRAIN STOREHOUSE.—George Clark, Buffalo, N. Y.
87,635.—COTTON GIN.—Robert J. Clay, Greenpoint, N. Y.
87,636.—CLOTHES-LINE FASTENER.—F. Clymer, Galion, Ohio. Antedated March 5, 1869.
87,637.—HARVESTER.—J. F. Coddington, Newark, N. J.
87,638.—CHURN DASHER.—C. L. Cole, Bushnell, Ill.
87,639.—CHURN.—E. Coleman, Woburn, Mass.
87,640.—MASH TUB AND VAPOR COOLER.—A. W. Cram, St. Louis, Mo.
87,641.—PLOW.—Hiram Culver, Dansville, N. Y.
87,642.—COMBINED HARROW AND CULTIVATOR.—H. Culver, Dansville, N. Y.
87,643.—HORSE HAY FORK.—J. Cummins, Perry, Mich.
87,644.—ELASTIC SEAT AND BACK FOR CHAIRS AND BOTTOM FOR BEDS.—Leo Davt (assignor to himself and John Wood), New York city. Antedated Nov. 20, 1868.
87,645.—PORTABLE KEY-HOLE GUARD.—W. E. Dante, Washington, D. C.
87,646.—WIND-WHEEL WATER ELEVATOR.—G. W. Darby, New Vienna, Ohio.
87,647.—BLIND AND SHUTTER FASTENING.—Wm. J. Decker, Nyack, N. Y.
87,648.—BRACE AND SUSPENDER COMBINED.—E. L. Demorest and W. G. Cook, New York city. Antedated March 5, 1869.
87,649.—RAILWAY CAR COUPLING.—L. M. Doddridge (assignor to himself and J. N. Templar), Portland, Ind.
87,650.—MANUFACTURE OF ARTIFICIAL FUEL.—Chas. du Lin, Mans, France.
87,651.—CORN PLANTER.—J. W. Eardly, Cascade, Mich.
87,652.—THIMBLE SKIN FOR AXLES.—M. Ehr Gott (assignor to himself and James Parker), Pittsburgh, Pa.
87,653.—ARTIFICIAL BONE BLACK.—H. Endemann, New York city.
87,654.—FIRE KINDLER.—M. E. Ezell, Hatchchubbee, assignor to W. S. Gordon, Russel county, Ala.
87,655.—BOOT AND SHOE LACING.—P. S. Foster, Richmond, Me.
87,656.—MILLSTONE BALANCE.—A. Frederick, Toledo, Ohio.
87,657.—CHURN.—A. S. Galliher, Bristol, Tenn.
87,658.—PROCESS OF PREPARING ETROLEUM TO BE USED IN LUBRICATING WOOL.—S. Gibbons, Freedom, Pa., assignor to Excelsior Oil Manufacturing Company of Pennsylvania.
87,659.—CHURN.—John Glatner, Suspension Bridge, N. Y.
87,660.—CHURN.—J. L. Good, Elizabethtown, Pa.
87,661.—PEN.—H. S. Goodspeed, New York city.
87,662.—STAIR ROD.—W. B. Gould, New York city.
87,663.—METHOD OF CONSTRUCTING MOLDS FOR METALLIC CASTINGS.—Wm. Hainsworth, Sharpsville, Pa.
87,664.—WATER METER.—A. W. Hall, New York city.
87,665.—ROTARY MOTOR AND METER.—Wm. Hamilton and Wm. Hamilton, Jr., Toronto, Canada.
87,666.—STEP AND EXTENSION LADDER.—H. J. Hancock, New York city.
87,667.—PORTABLE MILL.—B. Harnish and R. J. King, Lancaster, Pa.
87,668.—SKYLIGHT AND VENTILATOR.—G. Hayes, New York city.
87,669.—BLACKING STAFF FOR FACING MILLSTONES.—Abram Heartill, Louisville, Tenn.
87,670.—PACKING FOR ARTESIAN WELLS.—Peter C. Heinz, Pioneer, Pa.
87,671.—REFLECTOR FOR HEAD LIGHTS.—H. L. Hervey, Philadelphia, Pa.
87,672.—MATERIAL FOR THE MANUFACTURE OF CABINET AND OTHER WORK IN WOOD.—August Herzog, and John G. Roth, (assignors to American Ornamental Wood Manufacturing Company), New York city.
87,673.—WATER WHEEL.—D. Holdman and S. Goodwin, Waterloo, Iowa.
87,674.—BILLIARD GAME REGISTER.—E. Holmes and H. C. Roome, New York city.
87,675.—SPRING SEAT.—C. H. Hudson, New York city.
87,676.—CORN-STALK CUTTER.—H. Jackson, Elmira, Ill.
87,677.—SULKY PLOW.—John R. Jackson, Pelahatchee Depot, Miss.

- 87,678.—BAND TIGHTENER FOR SHOCKS OF CORN.—James C. Jay, Bear Creek township, Ind.
87,679.—FIREPROOF GRANARY.—G. H. Johnson (assignor to himself and G. Milsom), Buffalo, N. Y.
87,680.—VAPOR BURNER.—Joshua Kidd, New York city.
87,681.—CARBURETING GAS, AND OIL FOR THE SAME.—J. Kidd, New York city.
87,682.—APPARATUS FOR CARBURETING GAS.—J. Kidd, New York city.
87,683.—SASH HOLDER.—D. P. Lacey, Orfordville, Wis., assignor to R. R. Ball, West Meriden, Conn.
87,684.—BRUSH HANDLE.—C. L. Larder, Brooklyn, N. Y.
87,685.—RAILWAY CAR DOOR.—T. R. Leighton, Cameron, Mo.
87,686.—HAMES RING.—J. Letchworth (assignor to Pratt and Letchworth), Buffalo, N. Y.
87,687.—RAILWAY CAR AXLE.—E. T. Ligon, Demopolis, Ala.
87,688.—COOKING STOVE.—E. C. Little, L. E. Clow, and D. H. Nation, St. Louis, Mo.
87,689.—PAPER BAG MACHINE.—H. C. Lockwood, Baltimore, Md.
87,690.—CULTIVATOR PLOW.—Wm. Looker, Graham, Mo.
87,691.—CHURN.—J. L. Marsh, Centerville, Ind.
87,692.—SHEET-METAL SEAMING MACHINE.—John Mays and E. W. Bliss, Brooklyn, N. Y., assignors to Devoe and Pratt Manufacturing Company, New York city.
87,693.—MACHINE FOR PAGING BOOKS.—John McAdams, Brooklyn, N. Y.
87,694.—COVERING FOR BLIND DITCHES.—T. M. C. Lutes, New Mount Pleasant, Ind.
87,695.—PRINTING-PRESS FLY FRAME.—T. H. Mead, Boston, Mass., assignor to R. Hoe and Company, New York city.
87,696.—HORSE HAY FORK.—J. A. Miller, Shippensburg, Pa. Antedated Feb. 27, 1868.
87,697.—TRUCK FOR MOVING BUILDINGS.—John S. Millikan, Thornton, Ind.
87,698.—REGISTERING APPARATUS FOR STILLS.—John Minor, Peoria, and M. W. Nesmith and G. W. Nesmith, Metamora, Ill.
87,699.—HARVESTER RAKE.—John B. Morse and Loren L. Carter, Lafayette, Ind.
87,700.—SAWING MACHINE GUARD.—A. W. Pagett, Springfield, Ohio.
87,701.—MARBLE-SAWING MACHINE.—C. H. G. Pease, Danbury, Conn.
87,702.—TWEER.—J. J. Pierce, Emmett, Mich.
87,703.—MITER BOX.—John Pons (assignor to himself, J. S. Russell, and Henry Vogler), Baltimore, Md.
87,704.—SOLDERING MACHINE.—Charles Pratt, New York and Conrad Seimel, Greenpoint, N. Y., assignors to Charles Pratt.
87,705.—PEA PICKER.—Abner Quinn, Wilmington, N. C., assignor to himself and A. E. Wright.
87,706.—FANNING MILL.—B. F. Randell, Des Moines, Iowa.
87,707.—CHRONOMETER ESCAPEMENT.—George P. Reed, Boston, Mass.
87,708.—SASH HOLDER.—A. C. Rodgers (assignor to himself and J. and G. H. Gibson), Philadelphia, Pa.
87,709.—SHINGLING BRACKET.—Abner Rollo, Friendship, Wis.
87,710.—ICE-CREAM RECEPTACLE.—Edward A. G. Roulstone, Boston, Mass.
87,711.—ROAD SCRAPER.—W. W. Rumrill, Roanoke, Ind.
87,712.—GRAIN DRILL AND CORN DROPPER.—J. D. Sater and Turner Barns, Greensburg, Ind.
87,713.—VELOCIPEDE.—L. W. Serrell, Brooklyn, N. Y., assignor to Robert Foulds, Passaic, N. J.
87,714.—KEYHOLE GUARD.—Edmund E. Shepardson, Providence, R. I.
87,715.—BITSTOCK.—W. H. Sible, Harrisburg, Pa.
87,716.—CLAY PULVERIZER AND STONE SEPARATOR.—F. H. Smith, Baltimore, Md.
87,717.—SCREW BOLT AND LOCK NUT.—J. B. Smith, Milwaukee, Wis., assignor to himself and G. R. Chittenden, Chicago, Ill.
87,718.—PEA RAKE.—Silvester Skinner, Clayton, N. Y.
87,719.—EXTENSION PRUNING HOOK.—John Stark, Thomasville, Ga. Antedated Feb. 27, 1869.
87,720.—BRANDING IRON.—Lewis Stark, Chelsea, assignor to himself and F. L. Penney, Boston, Mass.
87,721.—REVOLVING CULTIVATOR.—Abraham J. Stevens, El Dorado, Wis.
87,722.—SHANK.—H. P. Stewart, Bath, Mich.
87,723.—TYPMAN FRAME FOR PRINTING PRESSES.—David U. Stoner, Mount Joy, Pa.
87,724.—CULTIVATOR.—D. C. Stover, Lanark, Ill.
87,725.—FURNACE FOR SMELTING ORES.—C. H. Swain, Brooklyn, N. Y.
87,726.—SEED SOWER.—H. R. Swank, West Jersey, Ill.
87,727.—STENCIL PLATE.—J. L. Tarbox and H. L. Tarbox, New York city.
87,728.—VALVE FOR BLOWING ENGINES.—Lewis Taws, Philadelphia, Pa.
87,729.—FENCE.—J. B. Tedrow, Chillicothe, Ohio.
87,730.—PRESERVE JAR.—Nathan Thompson, Brooklyn, E. D., N. Y.
87,731.—WASHING MACHINE.—H. B. Tibbitts, Vineland, N. J.
87,732.—BOTTLE-CORKING APPARATUS.—Hiram Unger, Logansport, Ind.
87,733.—COMPOSITION FOR RECUTTING FILES AND RASPS.—A. Van Camp, Washington, D. C.
87,734.—COMPOSITION FOR FIRE-KINDLING.—A. Van Camp, Washington, D. C.
87,735.—CARTRIDGE.—J. R. Van Vechten, New York city.
87,736.—MACHINE FOR SCRAPING AND LOADING EARTH.—Albert Ward, New Michigan, Ill.
87,737.—BACKBAND HOOK.—Seth Ward, Princeton, Ind. Antedated March 4, 1869.
87,738.—WHEEL.—J. C. Welch and M. A. Ammeden, Edgerton, Ohio. Antedated March 5, 1869.
87,739.—HINGE PINTLE.—William Wells, Ashtabula, Ohio.
87,740.—FISHING NET.—F. A. Werdmuller, New York city.
87,741.—IRON BRIDGE.—T. B. White, New Brighton, Pa. Antedated Feb. 27, 1869.
87,742.—BEDSTEAD.—H. K. Whitner, Philadelphia, Pa.
87,743.—CHURN.—Manuel Witmer, Cedar Rapids, Iowa.
87,744.—MACHINE FOR PRESSING HATS.—F. Wolfram, New York city.
87,745.—MEASURING FUNNEL.—H. J. Wolters, Salem, Mass.
87,746.—CAR WHEEL AND AXLE.—J. A. Woodbury, Boston, Mass.
87,747.—DEVICE FOR HEADING BOLTS.—J. M. Woods, Washington, Mo.
87,748.—TRITURATING AND AMALGAMATING APP RATUS FOR TREATING ORES OF GOLD OR SILVER.—Leonard Wray, Ramsgate, England.
87,749.—STIRRUP-STRAP LOOP.—A. B. Zellner, Monticello, Ark.

REISSUES.
9,781.—MOP HEAD.—Dated June 14, 1853; extended seven years; reissue 2,957, dated June 2, 1868; reissue 8,188, dated Nov. 10, 1868; reissue 8,322.—Colby Brothers & Co., Waterbury, Vt., assignees, by mesne assignments, of Harvey Murch.
60,657.—CUSHION FOR BILLIARD TABLES.—Dated Dec. 18, 1866; reissue 8,323.—Levi Decker, New York city.
70,668.—EXTENSION TABLE.—Dated Nov. 5, 1867; reissue 8,324.—F. R. Wolfinger, Chicago, Ill.

EXTENSIONS.
METHOD OF WORKING FRANKLINITE ORE.—Thaddeus Selbeck, Greenwich, Conn.—Letters Patent No. 12,829, dated Jan. 20, 1855.
HARVESTER.—Cyrenus Wheeler, Jr., Auburn, N. Y.—Letters Patent No. 12,867, dated Feb. 6, 1855; reissue No. 971, dated June 5, 1860; reissue No. 2,632, dated May 28, 1867.
ELLIPTICAL ROTARY PUMP.—Birdsill Holly, Lockport, N. Y.—Letters Patent No. 12,850, dated Feb. 6, 1855.
BASE-BURNING STOVES.—James Easterly, Albany, N. Y.—Letters Patent No. 12,382, dated February 13, 1855; reissue No. 3,009, dated June 30, 1868.
BASE-BURNING STOVES.—James Easterly, Albany, N. Y.—Letters Patent No. 12,382, dated Feb. 13, 1855; reissue No. 8,610, dated June 30, 1868.
AUGERS.—Russell Jennings, Deep River, Conn.—Letters Patent No. 12,818, dated Jan. 30, 1855; reissue No. 2,081, dated October 8, 1865; reissue No. 2,146, dated Jan. 18, 1866.
SCREW JACK.—Thomas C. Ball, Bellows Falls, Vt.—Letters Patent No. 12,464, dated Feb. 27, 1855.
METHOD OF OPERATING STEAM VALVES.—Norman W. Wheeler, Brooklyn, N. Y.—Letters Patent No. 13,869 dated July 855. Antedated March 1, 1855.

NEW PUBLICATIONS.

ANNUAL OF SCIENTIFIC DISCOVERY; or Year Book of Facts in Science and Art, for 1869. Exhibiting the most Important Discoveries and Improvements in the Arts and Sciences, together with Notes on the Progress of Science during the Year 1868; a List of Recent Scientific Publications, Obituaries of Eminent Scientific Men, etc. Edited by Samuel Kneeland, A. M., M. D., Fellow of the American Academy of Arts and Sciences, etc., etc. Boston: Gould & Lincoln, 59 Washington street; New York: Sheldon & Co.; Cincinnati: George S. Blanchard & Co.

The year of our Lord 1868 has been so crowded with discoveries and improvements, that the volume before us could scarcely be otherwise than one of unusual interest. The able manner in which the editorial work has been performed adds greatly to the intrinsic value of the recorded facts. The index (a matter of vital importance in a work of reference, although some compilers seem to think it otherwise, judging from the careless manner in which indexes are often prepared) is prepared with judgment and accuracy. The work is embellished with a very fine portrait of James D. Dana, Professor of Natural History and Geology in Yale College, which adds to the attractions of the volume.

THE ARCHITECTURAL REVIEW AND AMERICAN BUILDERS' JOURNAL, for March, is published at Philadelphia, and fully sustains the excellent character heretofore noticed in that publication.

Van Nostrand's ECLECTIC ENGINEERING MAGAZINE, New York, for March, is also at hand, with a variety of well-selected articles.

PATENT OFFICES, American and European, OF MUNN & CO., No. 37 Park Row, New York.

For a period of nearly twenty-five years MUNN & Co. have occupied the position of leading Solicitors of American and European Patents, and during this extended experience of nearly a quarter of a century, they have examined not less than fifty thousand alleged new inventions, and have prosecuted upward of thirty thousand applications for patents, and, in addition to this, they have made at the Patent Office over twenty thousand Preliminary Examinations into the novelty of inventions, with a careful report on the same.

This wide experience has not been confined to any single class of inventions but has embraced the whole range of classification, such as Steam and Air Engines, Sewing Machines, Looms and Spinning Machinery, Textile Manufactures, Agriculture and Agricultural Implements, Builders' Hardware, Calorifics, Carriages, Chemical Processes, Civil Engineering, Brick Making, Compositions, Felting and Hat Making, Fine Arts, Fire-arms, Glass Manufacture, Grinding Mills, Harvesters, Household Furniture, Hydraulics and Pneumatics, Illumination, Leather Manufactures, Mechanical Engineering, Metallurgy, Metal Working, Navigation, Paper Making, Philosophical Instruments, Presses, Printing and Stationery, Railroads and Cars, Sports, Games, and Toys, Stone Working, Surgical Apparatus, Wearing Apparel, Wood Working.

MUNN & Co. deem it safe to say that nearly one-third of the whole number of applications made for patents during the past fifteen years has passed through their Agency.

RECEIPTS.—When money is paid at the office for subscriptions, a receipt for it will be given; but when subscribers remit their money by mail, they may consider the arrival of the first paper a bona-fide acknowledgment of their funds.

CITY SUBSCRIBERS.—THE SCIENTIFIC AMERICAN will be delivered in every part of the city at \$3.50 a year. Single copies for sale at all the News Stands in this city, Brooklyn, Jersey City, and Williamsburg, and by most of the News Dealers in the United States.

Advertisements.

The value of the SCIENTIFIC AMERICAN as an advertising medium cannot be over estimated. Its circulation is ten times greater than that of any similar journal now published. It goes into all the States and Territories, and is read in all the principal libraries and reading-rooms of the world. We invite the attention of those who wish to make their business known to the unnumbered readers of a printed newspaper. He wants circulation. If it is worth 25 cents per line to advertise in a paper of three thousand circulation, it is worth \$3.50 per line to advertise in one of thirty thousand.

RATES OF ADVERTISING. Back Page.....\$1.00 a line. Inside Page......75 cents a line. Engravings may head advertisements at the same rate per line, by measurement, as the letter-press.

FOR SALE AT A BARGAIN.—A Part or Whole of a Valuable Patent. Full particulars and sample sent. S. & S. C. CARY, Middle st., South Brooklyn, N. Y.

PLATINUM. H. M. RAYNOR, 748 Broadway, N. Y.

TEN per cent COUPON BONDS OF THE CITY OF LANSING, the Capital of Michigan. For sale by A. WILKINS, Detroit, Mich.

MACHINIST FOREMAN WANTED IN New York.—A middle aged man, of experience, and capable to take charge and facilitate the manufacture of a standard machine. Address, stating reference and salary expected, Presses, New York Herald Office.

APPLICATION OF THE SLIDE VALVE AND LINK MOTION to Stationary, Portable, Locomotive, and Marine Engines, with new and simple methods for proportioning the parts. By William S. Auchincloss, Civil and Mechanical Engineer. Illustrated with 53 Plates, 1 vol. 8vo. In Press. D. VAN NOSTRAND, Publisher, No. 192 Broadway.

100 YARDS OF SHEETING For a Club of 100 in our great

One Dollar Sale

If all returned. A little extra exertion secures it. Send for circulars with new commission rates, before sending your club elsewhere. One trial will convince you that our terms to agents are not excelled, and the quality of our goods unequalled by any other use in our line of business. S. C. THOMPSON & CO., 136 Federal st., Boston, Mass.

CONSULTATIONS AND OPINIONS FREE.

Those who have made inventions and desire to consult with us are cordially invited to do so. We shall be happy to see them in person, at our office, or to advise them by letter. In all cases they may expect from us an honest opinion. For such consultation, opinion, and advice, we make no charge. A pen-and-ink sketch and a description of the invention should be sent. Write plainly, do not use pencil or pale ink.

If a SPECIAL SEARCH at the Patent Office is required, which embraces a personal examination of all patented inventions and a report in writing, a fee of \$5 is charged. This examination is only advised in doubtful cases.

To Apply for a Patent, a model must be furnished, not over a foot in any dimension. Send model to Munn & Co., 37 Park Row, New York, by express, charges paid, also a description of the improvement, and remit \$16 to cover first Government fee, revenue and postage stamps.

The model should be neatly made of any suitable materials, strongly fastened, without glue, and neatly painted. The name of the inventor should be engraved or painted upon it. When the invention consists of an improvement upon some other machine, a full working model of the whole machine will not be necessary. But the model must be sufficiently perfect to show, with clearness, the nature and operation of the improvement.

THE GREAT ADVANTAGES

OF MUNN & CO.'S AGENCY are that their practice has been ten-fold greater than any other Agency in existence, with the additional advantage of having the assistance of the best professional skill in every department, and a Branch Office at Washington, which watches and supervises all their cases as they pass through official examination. If a case is rejected for any cause, or objections made to a claim, the reasons are inquired into and communicated to the applicant, with sketches and explanations of the references; and should it appear that the reasons given are insufficient, the claims are prosecuted immediately and the rejection set aside and usually

WITHOUT EXTRA CHARGE.

MUNN & Co. are determined to place within the reach of those who confide to them their business the highest professional skill and experience.

Caveats are desirable if an inventor is not fully prepared to apply for Patent. A Caveat affords protection for one year against the issue of a patent to another for the same invention. Caveat papers should be carefully prepared.

Reissues.—A patent, when discovered to be defective, may be reissued by the surrender of the original patent and the filing of amended papers. This proceeding should be taken with great care.

Patents can be Extended.—All patents issued prior to 1861, and now in force, may be extended for a period of seven years upon the presentation of proper testimony. The extended term of a patent is frequently of much greater value than the first term, but an application for an extension, to be successful, must be carefully prepared. MUNN & Co. have had a large experience in obtaining extensions, and are prepared to give reliable advice

Interferences between pending applications before the Commissioners are managed and testimony taken; also Assignments, Agreements and Licenses prepared. In fact there is no branch of the Patent Business which MUNN & Co. are not fully prepared to undertake and manage with fidelity and dispatch

Designs, Trade Marks, and Compositions can be patented for a term of years; also new medicines or medical compounds, and useful mixtures of all kinds.

When the invention consists of a medicine or compound, or a new article of manufacture, or a new composition, samples of the article must be furnished, neatly put up. Also, send us a full statement of the ingredients, proportions, mode of preparation, uses, and merits.

EUROPEAN PATENTS.

American inventors should bear in mind that, as a general rule any invention that is valuable to the patentee in this country is worth equally as much in England and some other foreign countries. Five Patents—American, English, French, Belgian and Prussian—will secure an inventor exclusive monopoly to his discovery among ONE HUNDRED AND THIRTY MILLIONS of the most intelligent people in the world. The facilities of business and steam communication are such that patents can be obtained abroad by our citizens almost as easily as at home. MUNN & Co. have prepared and taken a larger number of European patents than any other American Agency. They have Agents of great experience in London, Paris, Berlin, and other cities.

For Instructions concerning Foreign Patents, Reissues, Interferences, Hints on Selling Patents, Rules and Proceedings at the Patent Office, the Patent Laws, etc., see our Instruction Book. Sent free by mail on application. Those who receive more than one copy thereof will oblige by presenting it to their friends.

Address all communications to

MUNN & CO., No. 37 Park Row, New York City

Office in Washington, corner of F and 7th streets.

Schedule of Patent Office Fees:

Table listing patent office fees: On each Caveat \$10, On filing each application for a Patent (seventeen years) \$15, On issuing each original Patent \$50, etc.

In addition to which there are some small revenue stamp taxes. Residents of Canada and Nova Scotia pay \$500 on application.

Inventions Patented in England by Americans.

[Compiled from the "Journal of the Commissioners of Patents."]

PROVISIONAL PROTECTION FOR SIX MONTHS.

- 333.—APPARATUS FOR FILTERING SACCHARINE SOLUTIONS.—R. W. Bender, New York city. Feb. 3, 1869. 337.—KNITTING MACHINE.—F. Gardner, Hamilton, Canada. Feb. 8, 1869. 403.—APPARATUS FOR HEATING AND VENTILATING.—John Johnson, Saco, Maine. Feb. 9, 1869. 431.—HARVESTER.—Elsha Foote, Washington, D. C. Feb. 11, 1869. 443.—ROTARY ENGINE.—William Owen, Toronto, Canada. Feb. 12, 1869. 455.—SAWS.—G. Maulick, T. P. Marshall, and G. W. Rowley, Trenton, N. J. February 15, 1869. 458.—MECHANISM FOR CHANGING SHUTTLES AND SHUTTLE BOXES IN LOOMS.—J. Briery, Worcester, and J. Briery, Millbury, Mass. February 15, 1869. 460.—EXTRACTING COPPER FROM ITS ORES.—T. S. Hunt, Montreal, and J. Douglas, Jr., Quebec, Canada. Feb. 15, 1869. 463.—DEVICES FOR LACING AND BUTTONING BOOTS AND SHOES.—Boston Shoe Stud, and Button Company (Incorporated), Boston, Mass. February 15, 1869. 472.—BRICK-MAKING MACHINERY.—Knight Brothers, Washington, D. C. February 16, 1869. 485.—ADHESIVE STAMPS FOR POSTAL, INTERNAL REVENUE, AND OTHER PURPOSES.—A. C. Fletcher, New York city. Feb. 17, 1869. 486.—PERMANENT WAY OF RAILWAYS.—C. H. Collins, New York city. Feb. 17, 1869.

PARKER'S POWER PRESSES.

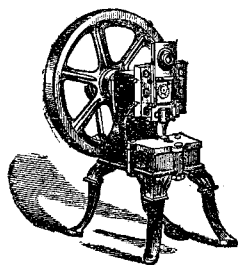

THESE PRESSES are what are universally known as the "Fowler Press," improved, and are without a rival as regards strength and durability, combined with delicacy of adjustment of the Punch. We have just received

A GOLD MEDAL

From the New Hampshire Art and Mechanics' Association, it being the First Premium awarded on Presses, and was given us over

STILES' POWER PRESS. Notice is hereby given that ALL PRESSES having an Eccentric Disk on the Crank Shaft, are direct infringements of our Patent, April 13, 1858, reissued Feb. 9th, 1859, and all parties are hereby cautioned against buying or using said Presses without our permission. PARKER BROTHERS, 11 26 West Meriden, Conn.

Styles' Patent Power Press,

MANUFACTURED AT MIDDLETOWN, Conn., and conceded by all to be the best Punching Press ever devised. We have not yet found it necessary to purchase

A GOLD MEDAL

To make it sell; but we have found it necessary to bring suit for infringement, and we hereby give

NOTICE

That last fall we commenced suit against PARKER BROTHERS, of Meriden, Conn., for infringement of our Patent; that, SINCE SAID SUIT was commenced, said Parker Brothers have hunted up and purchased an old patent, granted in 1838, for rolling paper blanks. This they have procured to be reissued (Feb. 9, 1859,) in the vain hope of defeating our rights. Trial will be had in April, when our Counsel assures us, our patent will be triumphantly sustained. Meantime all parties are hereby cautioned against purchasing or using the Parker Press, having an eccentric disk on the crank shaft for the purpose of adjusting the punch.

N. C. STILES, Middletown, Conn.

18 2

"EVERYBODY"

Should write AT ONCE and ascertain what we want of \$0,000 male and female agents. You can MAKE money by getting our Immense "Exchange List," free to everybody. EASTMAN & KENDALL, 25 Hawley st., Boston.

OLMSTEAD'S IMPROVED OILER, Always Right Side Up.

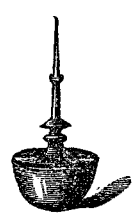

WARRANTED THE most durable Oiler made. The spring cannot be "set" by use, or the Oiler injured by falling. These Oilers are made of heavy Tin, Brass, and Copper, and are sold by the Trade everywhere. Address the Sole Manufacturer, J. H. WHITE,

157 and 159 Chestnut st., Newark, N. J., Manufacturer of SHEET and CAST METAL SMALL WARES, Stationers' and Trunk Makers' Hardware, etc., etc. Dies and Tools, Fancy Hardware, etc., made TO ORDER. 18 8

FOR SUPERIOR CORN SHELLERS address (the maker) C. KRATZ, Agt, for every description of machinery, Evansville, Ind. 13 1*

BAIRD'S CATALOGUE OF PRACTICAL & SCIENTIFIC BOOKS

Sent free of postage to any one who will furnish his address to HENRY CAREY BAIRD, Industrial Publisher, 406 Walnut St., PHILADELPHIA.

13 2

THE SPECIAL ATTENTION OF BUILDERS, ARCHITECTS, AND MECHANICS is called to SLOAN'S Architectural Review and Builder's JOURNAL,

An Illustrated Monthly, the publication of which was commenced in July, 1868. The terms are FIFTY cents for monthly part, or SIX DOLLARS per annum, payable in advance. Specimen numbers furnished on receipt of the subscription price. Send for a Prospectus. Back numbers supplied.

ALSO TO RIDDELL'S CARPENTER AND JOINER AND ELEMENTS OF HAND RAILING.

Second Edition. With thirty-three plates. By Robert Ridgell, author of "Elements of Hand Railing." Contents: Carpenter and Joiner, comprising 16 plates, and Elements of Hand Railing, comprising 17 plates. One vol., folio. Price \$7. Sent by mail on receipt of price. CLAXTON, REMSEN & HAFFELFINGER, Publishers, Booksellers, and Stationers, 819 and 821 Market st., Philadelphia.

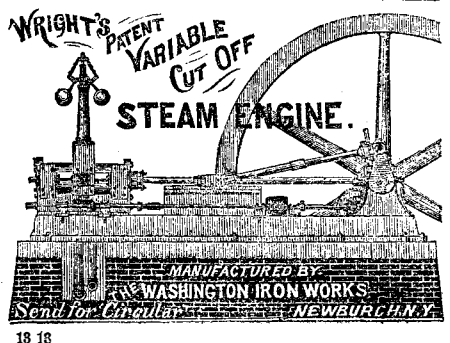

18 13

THE PAT. MOTH-PROOF FUR BOX.—A Splendid Chance for Agents, Male or Female. A Nest of 5 sent by express for \$2.50. Single box for \$1. It is neat, simple, light, and perfectly adapted to the purpose. Large discount to dealers and agents. S. MACFERRAN, No. 1307 Market st., Philadelphia.

THE PRACTICAL DRAFTSMAN'S BOOK OF INDUSTRIAL DESIGN AND MACHINISTS' & ENGINEERS' DRAWING COMPANION.

Forming a Complete Course of Mechanical, Engineering, and Architectural Drawing. From the French of M. Armeuand and the elder, Prof. of Design in Conservatoire of Arts and Industry, Paris, and MM. Armeuand the younger, and Amoroux, Civil Engineers. Rewritten and arranged with additional matter and plates, selections from and examples of the most useful and generally employed mechanism of the day. By WILLIAM JOHNSON, Assoc. Inst., C.E. Illustrated by fifty folio steel plates, and fifty wood cuts. A new edition, 4to,.....\$10

Among the contents are:—Linear Drawing, Definitions, and Problems. Sweeps, Sections, and Moldings. Elementary Gothic Forms and Rosettes. Ovals, Ellipses, Parabolas, and Volutes. Rules and Practical Data. Study of Projections, Elementary Principles. Of Prisms and other Solids. Rules and Practical Data. On Coloring Sections with applications—Conventional Colors, Composition or Mixture of Colors, Continuation of the Study of Projections—Use of Sections—details of machinery. Simple applications—spindles, shafts, couplings, wooden patterns. Method of constructing a wooden model or pattern of a coupling. Elementary applications. Rules and Practical Data.

THE INTERSECTION AND DEVELOPMENT OF SURFACES WITH APPLICATIONS.—The Intersection of Cylinders and Cones. The Delineation and Development of Helices, Screws, and Serpentine. Application of the helix—the construction of a staircase. The Intersection of surfaces—applications to stop-cocks. Rules and Practical Data. THE STUDY AND CONSTRUCTION OF TOOTHED GEAR.—Involute, cycloid, and epicycloid. Involute. Cycloid. External epicycloid, described by a circle rolling about a fixed circle inside it. Internal epicycloid. Delineation of a rack and pinion in gear. Gearing of a worm with a worm wheel. Cylindrical or Spur Gearing. Practical delineation of a couple of spur wheels. The Delineation and Construction of Wooden Patterns for Toothed Wheels. Rules and Practical Data.

CONTINUATION OF THE STUDY OF TOOTHED GEAR.—Design for a pair of bevel wheels in gear. Construction of wooden patterns for a pair of bevel wheels. Involute and Helical Teeth. Contrivances for obtaining differential Movements. Rules and Practical Data.

ELEMENTARY PRINCIPLES OF SHADOWS.—Shadows of Prisms, Pyramids, and Cylinders. Principles of Shading. Continuation of the Study of Shadows. Tuscan Order. Rules and Practical Data.

APPLICATION OF SHADOWS TO TOOTHED GEAR.—Application of Shadows to Screws. Application of Shadows to a Boiler and its Furnace. Shading in Black-Shading in Colors.

THE CUTTING AND SHAPING OF MASONRY.—Rules and Practical Data. Remarks on Machine Tools.

THE STUDY OF MACHINERY AND SKETCHING.—Various applications and combinations: The Sketching of Machinery. Drilling Machines, Motive Machines, Water-wheels. Construction and setting up of water wheels, Delineation of water wheels, Design of a water wheel, Sketch of a water wheel, Overshot Water wheels, Water Pumps, Steam Motors; High-pressure expansive steam engine. Details of Construction; Movements of the Distribution and Expansion Valves; Rules and Practical Data.

OBLIQUE PROJECTIONS. PARALLEL PERSPECTIVE. TRUE PERSPECTIVE.—Elementary principles. Applications—four mill driven by belts. Description of the mill. Representation of one of the mill in perspective. EXAMPLES OF FINISHED DRAWINGS OF MACHINERY.

The above or any of my PRACTICAL AND SCIENTIFIC BOOKS sent by mail, free of postage, at the publication prices, HENRY CAREY BAIRD, Industrial Publisher, 406 Walnut St., PHILADELPHIA.

Machinists' Tools.

BE SURE To call and see the Thomas Pat. Engine Lathes and Drills at the Thomas Iron Works, No. 5 Cypress st., Merrifield's Building, Worcester, Mass.

TO INVENTORS, MODEL MAKERS, MACHINISTS, etc.—The Subscriber offers for Sale, Cheap for Cash, his entire Stock and Fixtures, Machines, Tools, Patterns, and Materials.

THAT "STAR SPANGLED BANNER" Still Waves. See the April Number, just out, 40 Long Columns, overflowing with Wit, Humor, Fun, and Real Common Sense.

PAPER BAG Machines For Sale. Address 4 25* B. S. BINNEY, 64 Kilby st., Boston.

SCHWEITZER PAT. BOLT CO. Greenpoint, L. I. Office 120 Chambers st., New York.

BOILER FELTING SAVES TWENTY-five per cent of Fuel. JOHN ASHCROFT, 8 11* 50 John st., New York.

Combination Grate Bars GUARANTEED Best in Use. Rights for sale. Send for circular. PHILLIP GRIFFITH, Phil'a. Pa.

WOODBURY'S PATENT Planing and Matching and Molding Machines, Gray & Wood's Planers, Self-oiling Saw Arbors, and other wood working machinery.

BRONZE WORK. HAVING FITTED UP OUR FOUNDRY with special reference to the above class of Work.

Excelsior Lubricator. PATENTED AUG. 25th, 1868.—For Cylinders of Engines. A very Superior and Durable article.

\$245 A MONTH. TO AGENTS. 49 6 13* New and Useful Articles. Address JOHN J. HOWARD & CO., Alfred, Me.

FOR LINSEED AND COTTON-SEED OIL Machinery address W. P. CALLAHAN, Dayton, O.

Lucius W. Pond, IRON and Wood-working Machinery, Machinists' Tools and Supplies, Shafting, Mill Gearing, and Jobbing.

CHARLES PRATT'S ASTRAL OIL

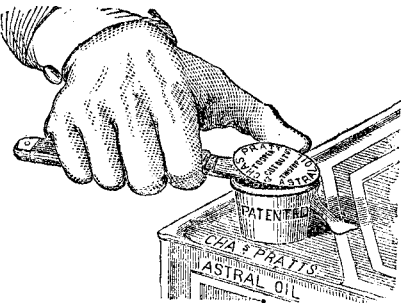

Is intended to supply a great Public Want for a Safe, Reliable Illuminating Oil. It is manufactured by us, and packed only in our Guaranty Patent Cans.

Perfectly Pure, no Mixture nor Chemicals. E. N. Horsford, late Rumford Prof., Harvard Univ., and R. Ogden Doremus, M.D., Prof. Chem., etc.

It is REMARKABLY CLEAR and FREE FROM DISAGREEABLE ODOR, and burns with a BRILLIANT FLAME, without OFFENSIVE SMELL.

Prices of Pratt's Astral Oil: Single Case, containing one Patent Can 5 galls., 60c. \$3 00 Double Case, containing two Patent Cans, 10 galls., 80c. \$6 00

WARD'S PATENT SPOKE MACHINES. The Best in Use. State County and Town Rights for sale.

PORTABLE STEAM ENGINES, COMBINING the maximum of efficiency, durability and economy, with the minimum of weight and price.

Sault's Patent FRICTIONLESS LOCOMOTIVE VALVES, easily applied; require no changes.

BENT, GOODNOW & CO., Boston, Mass. Agents for the sale of Patents. FOR SALE—A variety of very valuable "Rights." Send stamp for Containing descriptions of each.



HOW SHALL WE Paint our Houses? Ready Made Colors for Painting Exteriors of Country Houses.

THESE Paints require only to be thinned with Raw Linseed Oil to make them ready for use. The list includes forty shades and tints, comprising all the colors suitable for exterior painting.

Warranted Perfectly Pure Combination White Lead, which for economy and durability is the best in the market. For sale by all Paint Dealers throughout the country.

Mason's Lever Punch WILL Punch a hole through Iron 1-8 inch thick. See Description and Cut in No. 11, present Vol. Sci. Am. Price \$12, with one year and ditto.

Bridsburg Manfg Co., OFFICE No. 65 NORTH FRONT STREET, PHILADELPHIA, PA. Manufacture all kinds of Cotton and Woolen Machinery.

WROUGHT IRON Beams and Girders. THE Union Iron Mills, Pittsburgh, Pa. The attention of Engineers and Architects is called to our improved Wrought-iron Beams and Girders.

RICHARDSON, MERIAM & CO., Manufacturers of the latest improved Patent Daniel's and Woodworth Planing Machines, Milling, Sash and Molding, Tenoning, Mortising, Boring, Shaping, Milling and Circular Re-sawing Machines, Saw Mills, Saw Arbors, Scroll Saws, Railway, Cut-off, and Rip-saw Machines, Spoke and Wood Turning Lathes, and various other kinds of Wood-working Machinery.

GREAT ECONOMY IN WATER POWER. LEFFEL'S DOUBLE TURBINE WATER WHEEL—Best Wheel in Existence.—Manufactured by JAS. LEFFEL & CO., at Springfield, Ohio, and New Haven, Conn.



ROBERT McCALVEY, Manufacturer of HOISTING MACHINES and DUMB WAITERS.

BUERK'S WATCHMAN'S TIME DETECTOR.—Important for all large Corporations and Manufacturing concerns—capable of controlling with the utmost accuracy the motion of a watchman of patrolman, as the same reaches different stations of his beat.

Leather Belting, Card Clothing, & Hose Factory. J. H. Haskell, Baltimore.

Power Hammers. HOTCHKISS' PAT. Air Spring Hammers; W. H. WATER'S PAT. Drop Hammers.

SHEET and Roll Brass, BRASS AND COPPER WIRE. German Silver, etc., Manufactured by the THOMAS MANUFACTURING CO., Thomaston, Conn.

H. BOARDMAN, Lancaster, Pa.—Superior Patent Cork-cutting Machinery, Hard-laid Twine, Cord, and Rope Machinery, with Pat. Stop & Condenser.

STOCKS, DIES, AND SCREW PLATES, Horton's and other Chucks. JOHN ASHCROFT, 50 John st., New York.

STEAM HAMMERS, TURN-TABLES, and Foundry Cranes. Address GREENLEAF & CO., Indianapolis, Ind.

LATHE CHUCKS—HORTON'S PATENT —from 4 to 36 inches. Also for car wheels. Address E. HORTON & SON, Windsor Locks, Conn.

VELOCIPED WHEELS. MANUFACTURED BY S. N. BROWN & CO., Dayton, Ohio.

They also make a prime article of Spokes and Hubs for Light Carriage and Buggy Wheels. Send for price list.

IRON PLANERS, SHAPERS, LATHES, SCREW MACHINES, etc., Manufactured by TWISS, PRATT & HAYES, New Haven, Ct. Send for circulars.

Ornament Iron Works. CAST, WROUGHT IRON, AND WIRE RAILINGS, Fountains, Vases, Verandas, Settees, Chairs, Iron Stairs, Spiral and Straight WIRE WORK.

MACHINERY.—S. C. HILLS, No. 12 Platt st., New York, dealer in all kinds of Machinery and Machinists' supplies.

MASON'S PAT. FRICTION CLUTCHES are Manufactured by Volney W. Mason & Co., Providence, R. I. Agents, R. BROOKS & CO., 133 Ave. D, New York; TAPLIN, RICE & CO., Akron, Ohio.

Brick Machine. LAFLE'S NEW IRON CLAD HAS MORE advantages combined in one machine than any other ever invented.

AMERICAN TINNED SHEET IRON. Coating uniformly over the entire sheet, by an entirely new and patented process. All sizes and gages on hand and made to order.

P. S. STUBS. ILLUSTRATED PRICE LIST OF P. S. STUBS Tools and Files, Twist Drills and Chucks, Steel Lettors and Figures, Screw Plates and Taps, Machine Screws, Emery Wheels, etc.

MERRICK & SONS, Southwark Foundry, 430 Washington Ave., Philadelphia, Pa.

MANUFACTURE NASMYTH & DAVY STEAM HAMMERS, CORNISH PUMPING, BLAST, HORIZONTAL, VERTICAL, AND OSCILLATING ENGINES.

23261 TOWNS—23261 Agents Wanted. HAND SLITTING SAWS—one man rip 3-in. wide. 12-inch board per minute 600 feet per hour.

CINCINNATI BRASS WORKS.—Engine Builders' and Steam Fitters' Brass Goods.

Union Vise CO., of Boston, Mass. Pipe and Heavy, warranted, Woodworkers and Covered Screw, 50 sizes and styles constantly on hand.

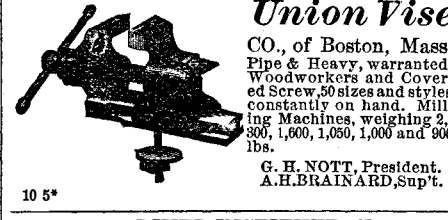

HUDSON RIVER INSTITUTE, Claverack, N. Y. A first-class Boarding School for both sexes.

A WATCH Free—Given gratis to every live man who will act as agent in a new, light and honorable business paying \$30 per day sure. No gift enterprise. No humbug. No money wanted in advance.

VINEGAR FROM CIDER WINE, MOLASSES, or Sorghum, in 10 hours, without using acids or drugs. For terms and other information, address F. I. SAGE.

SOLUBLE GLASS—For Cementing, Painting, Softening Hard Water, Production of Artificial Stone, Rendering Wood and other Organic Matter Proof against Dry Rot and Fire.

CATALOGUES SENT FREE. MATHEMATICAL INSTRUMENTS, 112 pages. OPTICAL INSTRUMENTS, 112 pages. MAGIC LANTERNS and STEREOPTICONS, 100pp. PHILOSOPHICAL INSTRUMENTS, 84 pages.



W. W. TUPPER & CO.'S PAT. GRATES. Make More Steam, with Less Fuel, do not warp, and are Cheaper than other Grates.

WROUGHT-IRON Pipe for Steam, Gas, and Fittings, etc. JOHN ASHCROFT, 50 John st., N. Y.

THE NOVELTY IRON WORKS—No. 24 and 26 Central corner Union street, Worcester, Mass. Manufacture the most approved Turbine Wheel and Water Meter now made.

ASHCROFT'S LOW-WATER DETECTOR will insure your Boiler against explosion. JOHN ASHCROFT, 50 John st., New York.

SHINGLE AND HEADING MACHINE—Law's Patent. The simplest and best in use. Shingle Heading and Stave Jointers, Stave Cutters, Equalizers, Heading Turners, Planers, etc.

OIL, OIL, OIL. PEASE'S IMPROVED OILS! London, 1862. PRIZE MEDALS. Paris, 1867 Railroads, Steamers, and for Machinery and Burning.

F. S. PEASE, Oil Manufacturer, Nos. 61 and 63 Main street, Buffalo, N. Y.

EMPLOYMENT that pays. For particulars, address S. M. SPENCER & CO., Brattleboro, Vt.



THE BEST and CHEAPEST in MARKET. The bolt revolves, is discharged without being run back, and a perfect clean cut is made with one passage.

THE WHITLOCK EXPOSITION. A Perpetual Fair, 35 and 37 Park Place. For full particulars send stamp for sample copy of THE WHITLOCK EXPOSITION REPORTER.

PATENT DIAMOND OR MINERAL Carbon Stone Dressers or Cutters, for Drilling, Sawing, Planing, Turning, Shaping, Carving, Engraving, and Dressing Mill or other Stones.

TO THE WORKING CLASS—I am now prepared to furnish all classes with constant employment at their homes, the whole of the time, for the spare moments.

Blake's Patent Gages, FOR HIGH OR LOW PRESSURE STEAM. Vacuum, Hydraulic, Air Blast, Testing Gas Pipe, and Dentist's use.

FRESH GARDEN and FLOWER SEEDS, prepared by mail. For 10c. per oz., the best sorts Asparagus, Beet, Carrot, Parsnip, Radish, Spinach, and Turnip.

\$3000 SALARY. Address U.S. Piano Co N.Y.

STEAM AND WATER GAGES, STEAM Whistles, Gage Cocks, and Engineers' Supplies. JOHN ASHCROFT, 50 John st., New York.

MODELS, PATTERNS, EXPERIMENTAL, and other machinery, Models for the Patent Office, built to order by HOLSKE MACHINE CO.

FOR STEAM ENGINES, BOILERS, SAW Mills, Cotton Gins, address the ALBERTSON AND DOUGLASS MACHINE CO., New London, Conn.

PAGE'S GREAT WATER FLAME COAL, Patented Lime Kiln will burn No. 1 finishing lime with any coal or wood, mixed or separate, in same kiln.

THE Tanite Emery Wheel Cuts fast, does not glaze, gum, heat, or smell, and is cheap. For circular, address THE TANITE CO., Stroudsburg, Pa.

CAMDEN Tool and Tube Works, Camden, N. J. Manufacturers of Wrought Iron Tube Brass Work and Fittings.

R. BALL & CO., Worcester, Mass. Manufacturers of Woodworth's, Daniel's, and Dimension Planers, Molding, Matching, Tenoning, Mortising, Shaping, and Boring Machines.

GARDNER'S GOVERNOR and AUTOMATIC STOP ACTION insures regularity of speed and safety from accident. Send for Circular.

WOODWORTH PLANERS a SPECIALTY —From new patterns of the most approved style and workmanship. Wood-working Machinery generally.

WITHERBY, RUGG & RICHARDSON.

Advertisements.

Advertisements will be admitted on this page at the rate of \$1.00 per line.

Ball, Black & Co., 565 and 567 BROADWAY, MANUFACTURERS OF ENGLISH STERLING Silver Ware.

THE FACILITIES OF BALL, BLACK & CO. FOR MANUFACTURING, ENABLE THEM TO OFFER A LARGER VARIETY OF PATTERNS, AND AT LOWER PRICES THAN ANY OTHER HOUSE IN THE TRADE.

SAW MILLS, PLANERS, MATCHERS, etc., by S. HEALD & SON, Barre, Mass.

Positive Steam Pump. Send for prices to J. W. COLE, 205 Broadway.

SOLID EMERY WHEELS—Silicate or Vulcanite; the only trustworthy wheels ad.

JUTE FACTORY FOR SALE.—Factory for the manufacture of Jute Carpets, Burlaps, & Twines.

RIGHTS IN ANY FORM FOR SALE.—In a valuable Patent Household Article, and used everywhere.

A Milling Machine for sale, price \$210. Also, 5-ft. Floor Drill Lathe, price \$75.

PATENTS SOLD, and Patent Goods Manufactured on Royalty or Sold on Commission.

"The Franklin Brick Machine," Tempers the Clay, brings out the molds, and makes 2,500 to 3,500 first-class Bricks per hour.

TOOL CHESTS VELOCIPEDES & LATHES. SEND FOR ILLUSTRATED CATALOGUE TO GEO. PARR, BUFFALO.

NEW INVENTION.—NESTER'S COMBINED CARPENTER'S TOOL—Saves one fourth of the Labor at Weather Boarding.

HELIOGRAPHIC STEEL ENGRAVING AND PRINTING CO., F. VON EGLOFFSTEIN, Sup't, 133 and 135 W. 25th st., N.Y.

WATER WHEELS. THE Duplex Turbine, NOT Equaled by any wheel in existence.

MECHANICAL DESIGNERS ENGRAVERS ON WOOD. KNAPP & CO., 8 and 10 John St., N. Y.

Reynolds' Turbine Water Wheels. No Complex, Duplex, or Triplex complications. All such are costly, perishable, easily clogged, inaccessible.

EAGLE ANVILS and PARALLEL CHAIN VISES. MANUFACTURED ONLY BY FISHER & NORRIS, Trenton, N. J.

INCREASE TWIST DRILLS, FLUTED HAND REAMERS, exact to Whitworth's Gage, and Beach's Patent Self-centering Chuck, manufactured by Morse Twist Drill and Machine Co., New Bedford, Mass.

FREE.—Our New Catalogue of Improved STENCIL DIES. More than \$200 A MONTH'S being made with them.

A reliable time-keeper is now an article of necessity to every one, and as such the Genuine Waltham Watches, with the late improvements, are superior to all others.

WIRE ROPE. Manufactured by JOHN A. ROEBLING, Trenton, N. J.

IRON.—W. D. MCGOWAN, IRON BROKER, 78 Water St., Pittsburgh, Pa.

PATENT SOLID EMERY WHEELS, Specially adapted to Grinding Saws, Mills, and Edge Tools.

WM. D. ANDREWS & BROTHER, 414 Water St., New York, Manufacture Patent Smoke-burning & Superheating Boilers.

POOLE & HUNT, Baltimore, Manufacture Leffel's Double Turbine Water Wheels.

PATENT BAND-SAW MACHINES, Manufactured by FIRST & PRYBIL, 176 and 177 Hester St., New York.

CHICOPEE SEWING MACHINE.—1st-Class, and fully licensed. AGENTS WANTED.

\$18,000. FOR SALE.—A Substantial Two-set Knitting Mill, with Machinery, etc., all nearly new.

FOR SALE.—Complete Outfit for Drying 25,000 Bricks per day, comprising the following articles: viz.—Seven tons 30 lb. Railroad Iron.

FOR ALL LIGHT WORK ERICSSON'S Caloric Engine FURNISHES THE MOST ECONOMICAL, DURABLE, RELIABLE POWER.

B.F. STURTEVANT'S NEW PATENT IMPROVED IRON PRESSURE BLOWERS MANUFACTORY & SALES ROOM 72 SUDBURY ST. BOSTON.

IRON PLANERS, ENGINE LATHES, Drills, and other Machinists' Tools, of Superior Quality.

GENUINE OROIDE GOLD WATCH CO. GENEVA, SWITZERLAND.

Agents WANTED.—Unlocated territorial agencies now ready. Energetic men realize from Three to Five Thousand Dollars yearly.

JOHN FOGGAN, Pres't Oroide Gold Watch Co., Only Office in the United States, No. 78 NASSAU STREET, New York.

PATTERN LETTERS to put on Patterns for Castings, etc., KNIGHT BROS., Seneca Falls, N. Y.

Woodward's National ARCHITECT. A Practical Work, Just Published, containing 1,000 Designs, Plans, and Details to Working Scale.

PRICE Twelve Dollars, postpaid. Send stamp for Catalogue of all Books on Architecture. Address GEO. E. WOODWARD, Publisher, 191 Broadway, New York.

ASBESTOS. This wonderful mineral differs from all others in possessing fine, silk-like fibers, which are indestructible by fire.

DESCRIPTIVE CIRCULARS. Prices and any further desired information will be furnished free by mail on application to H. W. JOHNS, Manufacturer of Improved Roofing Materials.

EMERSON'S PATENT PERFORATED CIRCULAR & LONG SAWS. REQUIRE NO GUMMING. FOR DESCRIPTIVE PAMPHLET ADDRESS AMERICAN SAW CO., Factory, Trenton, N. J.

Factory, Trenton, N. J. Office, No. 22 Jacob St., N. Y. Branch Office for Pacific Coast, No. 606 Front St., San Francisco, Cal.

VAN NOSTRAND'S Eclectic Engineering Magazine. Selected from the Home and Foreign ENGINEERING SERIALS.

History of Decarburizing Iron—Power Consumed by Drills—Purifying Iron Ores—Moldau Suspension Bridge at Prague—The Metal Hydrogen—The Strength of Corrugated Iron—The Hercules Iron-clad—Railways for China—The Lake Constance Railway Ferry—Traction Engines in France—The "Universal" Rolling Mill—Stress Diagrams for Straight-rafter Roofs—Railway Station Architecture—Morton's Ejector Condenser—Examination of Civil Engineers—Gas as a Caloric Agent—Bridge Construction—Steep Railway Gradients—Photography—The Bessemer Process—Cheaper Railways and Working—Sewage—The Suez Canal—Railway Accidents—Progress of Electro-metallurgy—Resistance and Transmission of Motion—The Drying Properties of various Paints—Recent Railway Works and Projects—The Construction of Reservoirs—Foster's Rail Joint—Experimental Researches on the Mechanical Properties of Steel—The Pneumatic Despatch—Breaking Iron and Steel Masses—Iron and Steel Notes—Railway Notes—Notices of New Publications—Miscellaneous.

D. VAN NOSTRAND, Publisher, 192 Broadway, New York. Copies of our new Catalogue of American and Foreign Scientific Books, 56 pp. 8vo., sent to any address on receipt of six cents in postage stamps.

THE WOODWARD STEAM PUMP MANUFACTURING COMPANY, Manufacturers of the Woodward Pat. Improved Safety Steam Pump and Fire Engine, Steam, Water, and Gas Fittings of all kinds.

Manufacture, on strictly scientific principles, style, finish, durability, and color (18 carat gold) a fac simile of the most costly description of Gold Watches. They are manufactured with Hunting Cases, Ladies' and Gentlemen's fine Swiss Movements, \$15; Patent Levers, \$20; Gentlemen's fac simile Waltham Patent Levers, \$20; Chronometer Balance, \$25. Elaborately engraved. Railroad Conductors, Engineers, Expressmen—the most exacting of our customers—have thoroughly demonstrated the strength, durability, accuracy, and utility of our celebrated watches, and pronounce them invaluable as reliable time-keepers.

Philadelphia Advertisements.

Philadelphia Advertising Patrons, who prefer it, can have their orders forwarded through T. V. Carpenter, resident Agent, 506 Poplar st.

The Harrison Boiler THIS IS THE ONLY REALLY SAFE BOILER in the market, and can now be furnished at a GREATLY REDUCED COST.

CHESTERMAN'S WIRE-WOVEN TAPE MEASURES, No. 34 L, from 83 feet to 100 feet long.

THE DOLLAR SUN. Chas. A. Dana's Paper. The cheapest, neatest, and most readable of New York Journals.

STEAM ENGINES. FROM 4 TO 200-HORSE POWER—Including COLLIER PATENT CUT-OFF ENGINES, SLIDE VALVE STATIONARY ENGINES, and PORTABLE ENGINES.

PHILOSOPHICAL INSTRUMENTS. Price Lists sent free upon application to Francis & Milligan, 126 South 8th st., Philadelphia.

THE Mercantile Agency's REFERENCE BOOK, for 1869, contains nearly half a million names, MARKETS FROM RECENT REVISIONS.

BODINE'S JONVAL TURBINE WATER Wheel, combining great economy in the use of water, simplicity, durability, and general adaptation to all positions in which water can be used as a motive power.

MECHANICS WILL FIND THE Scientific American

The Best Paper for Them Now Published. It is the most Popular Journal in the world, devoted to Invention, Mechanics, Manufactures, Art, Science, and General Industry.

THE SCIENTIFIC AMERICAN Has been Published for nearly a quarter of a Century and has a larger circulation than all other paper of its class in this country and in Europe.

Superb Illustrations by our own artists, of all the best Inventions of the day and descriptions and illustrations of LEADING MANUFACTURING ESTABLISHMENTS, MACHINES, TOOLS AND PROCESSES.

Inventors and Patentees will find in each number an official List of Patents, together with descriptions of the more important Inventions, with decisions in Patent Cases and points of law affecting the rights and interests of Patentees.

TERMS OF SUBSCRIPTION:—\$3.00 a year, \$1.50 for six months. \$1 for four months. To clubs of ten and upward, the subscription is only \$25.00 per annum each.

MUNN & CO., Publishers, 37 Park Row, New York.

TO INVENTORS. Letters Patent Are referred to an advertisement on another page. An Illustrated Pamphlet containing the Patent Laws, and full particulars concerning the obtaining of Patents, will be mailed free on application relative to Foreign Patents and their cost furnished free.