

# Scientific American

A JOURNAL OF PRACTICAL INFORMATION IN ART, SCIENCE, MECHANICS, AGRICULTURE, CHEMISTRY, AND MANUFACTURES

VOL. 1.—No. 7.

NEW YORK, AUGUST 13, 1859.

NEW SERIES

## IMPROVED GRAIN SEPARATOR.

Farmers, after the harvest, will begin to look about for winter work, and seeing if all their machinery is in order for doing it, so that this is a very proper time for calling their and millers' attention to the grain separator invented by W. R. Cox, of Delhi, Iowa, and which is represented in the accompanying engravings, Fig. 1 being a perspective view, and Fig. 2 a vertical section of its whole length. A is a trunk but slightly inclined from a longitudinal position, connected at one end with a fan-box, B, in which there is a rotary blast from C, that can be rotated by any suitable means. To the bottom of the trunk, A, are three spouts, D E F. The spouts, D and E, are inclined in the same direction, and F is slightly inclined the other way. H is a hopper attached to the elevated end of the trunk, A, the opening, *a*, of which into the spout, F, can be regulated by a slide, *b*. To the lower end of F a spout, I, is attached, and this connects the interior of F with the interior of E. In the inside of F, opposite the opening, *a*, a series of deflectors, *c*, are placed entirely across the spout, and in the lower part of E, opposite the opening of I, a similar series, *d*, are placed, all of them being of semi-cylindrical form. In the upper part of the trunk, A, a regulating valve, J, is placed, which has its end connected by a cord, K, that passes over a pulley with a weight, L, which can be adjusted to give any desired strength to the blast.

The operation is as follows: The fan, C, being set in motion, and the grain to be cleaned being placed in the hopper, H, the grain falls through the opening, *a*, into the spout, F, and strikes against the deflectors, *c*, which spread or scatter it directly over the discharge-end of the spout, so that the blast generated by the fan, C, will pass through the grain and act upon it in the most efficient manner. The light impurities are carried up by the blast into the fan-box, B, and are thrown off at a side spout, while the heavier impurities, light grain, &c., that are able to a certain extent to resist the action of the blast, fall into D. The sound grain falls into trough I, and, so passing into E, it is spread by the deflectors, *d*, and is again exposed to the action of the blast, which separates all the remaining impurities. The weight, L, is so arranged that it will allow the valve, J, to open the moment the blast becomes too strong, and so prevents any sound grain passing into D. The contents of D can be removed by opening the trap, G, or it can be opened partially to give a regular discharge.

This is a very compact and good machine, and it can be used either with or without other machinery, as a smut

machine or winnower. The patent is dated November 2, 1858, and the inventor will be happy to give any further information upon being addressed at Fulton, N. Y., until October, and afterwards at Delhi, Iowa.

## DRAWING WATER FOR IRRIGATION.

In our last issue, we gave our assent to the practicability of the irrigation system proposed by our Canadian correspondent on page 85. With our views, a corres-

pondent—J. B., of Newark, N. J.—disagrees, and his reasons for so doing deserve consideration. He says:—"I beg leave respectfully to differ from you, the first time I have had reason to do so in any opinion expressed

owing, principally, to the difficulty of getting pipes perfectly air-tight. It is my opinion, if any pipe (except lead, which would be very expensive) would answer the purpose, it would be the composite wrought-iron and cement tubing manufactured in Jersey City. That pipe, when in contact with the earth, is perfectly air-tight, as far as I have been able to test it, which I have done to a considerable extent in the distribution of gas. I once endeavored to supply the gas works at Albany, N. Y., with water by drawing it from the river, about one-half a mile, to an elevation of 28 feet, and, although I took great care in joining the pipes before and after laying them, they failed to answer the purpose."

Our correspondent is correct in regard to the necessity of having the suction pipe perfectly air-tight in drawing water a considerable distance. Trusting to our memory, we think we are not mistaken in having seen water, in more than one case, drawn by steam-engines to as great a distance as from the river in Albany to Broad-street, near where the gas works are located, and to an elevation equal to 28 feet. The cast-iron water-pipes laid in Brooklyn, which are coated with hot asphalt, are perfectly air-tight; and our correspondent in Canada must take care and see to this arrangement if he proceeds with the system of irrigation which he has proposed. He must also make allowance for the diminished pressure of the atmosphere according to the altitude of his residence.

## IMPORTANT PATENT EXTENSION.

The patent granted to Hale & Goodman, of North Dana, Mass., for improvements in planing irregular forms in wood, July 22, 1845, has lately been extended by the Commissioner of Patents, through the agency of Munn & Co., for a term of seven years.

The invention is one of much importance and value. By its use, the various ornamental forms employed for the legs of billiard-tables, stools, pianos, and other musical instruments, are produced with astonishing rapidity and precision.

Prior to 1845, all such legs were planed and prepared to receive the veneers by hand-labor exclusively. But, in consequence of the invention above-mentioned, the trade has been wholly revolutionized. Nearly the whole of this class of work is now done upon Hale & Goodman's machines. A single machine is said to be capable of doing the work in one day which formerly required the active labor of 100 men! Truly, this is an age of improvements. From 800 to 1,000 pairs of legs, we are informed, are weekly turned out at the establishment of Messrs. Hale & Goodman, at North Dana, Mass.

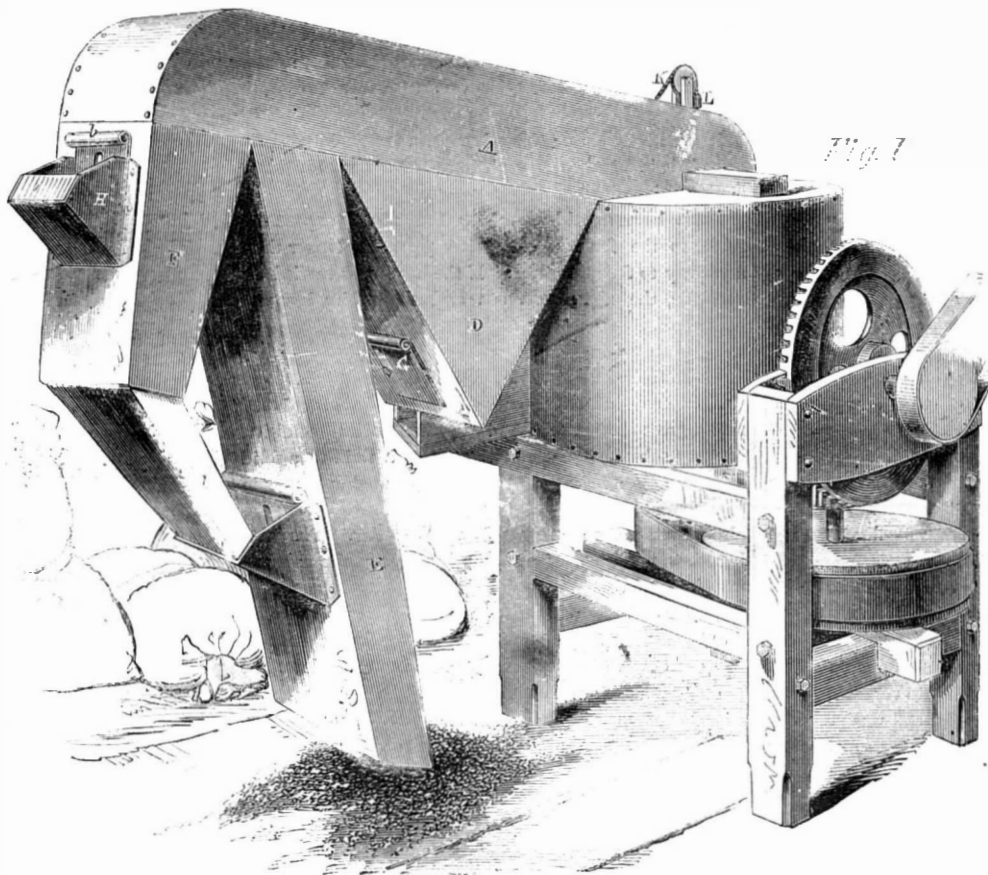

COX'S IMPROVED GRAIN SEPARATOR.

pondent—J. B., of Newark, N. J.—disagrees, and his reasons for so doing deserve consideration. He says:—"I beg leave respectfully to differ from you, the first time I have had reason to do so in any opinion expressed

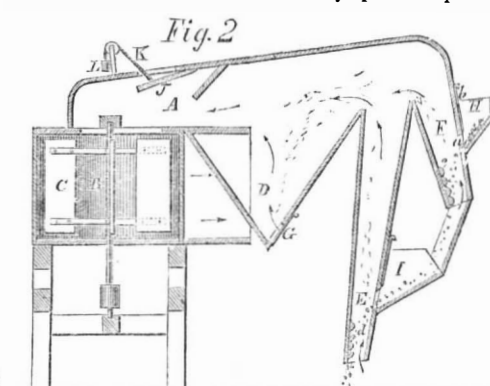

by you in your valuable journal. While it may be theoretically true that water may be drawn by a suction to an elevation of 28 to 30 feet, and a distance of one-half a mile, practically it is very difficult, if not impossible, to get any satisfactory result under such circumstances,

## THE METALS OF MISSOURI.

The State of Missouri appears to be rich in iron ores than any other on our continent, and lead and copper are also very abundant. With her great natural resources of the most useful metals, this State, at some distant day, will no doubt be renowned for its iron manufactures. The famous Pilot Knob, in Missouri, is a hill of iron 500 feet high, and one mile in circumference. The ore crops out on all its sides, and laborers quarry it like free stone. From external indications it appears to be nearly all iron. A correspondent of the *Toledo Blade*, who has lately visited it, says:—"It yields, under very crude management, 50 per cent of iron. The indications of iron at the Iron Mountains are equally marvelous. Calculations have been made of the quantity of iron in those hills (mere approximations of course), which make it amount to 600,000,000 tons; a quantity sufficient to supply one hundred millions of people, with 24 pounds each, for 500 years, if it was accessible to them all. The iron is said to be very malleable, and hence very desirable for all those uses and purposes for which such qualities are required. No large quantities of the pig are now used at St. Louis, though it can be transported cheaply by the Iron Mountain Road, which connects the mines with the city. The difficulty of obtaining an abundance of coal, at cheap enough rates and free from sulphur, is said to be the present difficulty in the way of making St. Louis a great mart of iron manufactures—even greater in this respect than Pittsburgh. The iron, when cast into harness fixtures and ornamental work, receives a polish like burnished silver. Much of the silver plating on harness used in our country is merely polished iron from the Missouri Iron Mountains."

Lead is also very abundant in Missouri. In Jefferson county there are 280 square miles of lead fields. In Madison county there are lead, cobalt and nickel veins. In St. Francis county are Valle's lead mines, from which \$40,000 worth of this metal have been produced annually for twenty years. In several other districts gold, silver, copper and tin are reported to have been discovered.

NEW METHOD OF SOLDERING ALUMINIUM.  
[Translated from the *Wurtemberg Journal of Trades*.]

Since the metal aluminium was first obtained in small quantities by Professor Woehler, in Goettingen, and more particularly since the French chemist, Sainte-Claire Deville, succeeded in producing this metal in larger quantities, it has been employed in various ways, and it is exported from France in considerable quantities in a crude state as well as manufactured into various articles.

A still more extensive use of said metal was prevented by the impossibility of soldering it, but after a great many unsuccessful experiments, Mr. T. Mourey (Rue Fontaine au Roi, nro. 12) has succeeded in discovering a method for soldering it which fulfills all conditions necessary to render it perfectly practicable.

Mr. Mourey's method consists in the employment of two different sorts of solder—one soft and the other hard. The former serves as a dressing for the surfaces which are to be united, and the harder composition is the solder. Five different compositions are used by Mr. Mourey:—

- |                        |                       |
|------------------------|-----------------------|
| 1. 80 parts of zinc.   | 4. 92 parts of zinc.  |
| 20 parts of aluminium. | 5 parts of aluminium. |
| 2. 85 parts of zinc.   | 5. 94 parts of zinc.  |
| 15 parts of aluminium. | 6 parts of aluminium. |
| 3. 88 parts of zinc.   |                       |
| 12 parts of aluminium. |                       |

In order to produce these compositions, the necessary quantity of aluminium divided into small pieces is melted in a good fire-proof crucible, introducing piece after piece, so that the molten mass is always cooled off a little by the fresh supply. After the whole mass has thus been melted it is stirred up by an iron rod and the zinc is introduced, also divided into small pieces. The composition is well stirred with the iron rod, and in order to exclude the atmospheric air, which would have a tendency to oxydize the zinc, a small piece of tallow or lard is added. The mass is now poured out into molds and formed into bars like soft solder. Good care must be taken to keep the zinc from evaporating, whereby the composition would be rendered brittle. It is also necessary to have the zinc as clean and free from iron as possible.

The fusing temperature of these different compositions is different, that of No. 1 being the highest, and each of

the succeeding ones being a few degrees lower. The composition No. 1 can therefore be used as solder if No. 2, or any of the others, has been used as a dressing; or No. 4 may be used as a dressing and No. 2 as a solder, and so on.

If it is now desired to unite two articles, such as the leg and the body of a coffee-pot, the respective surfaces are cleaned off and made rough by means of a file, and the articles are now placed on heated charcoal. At the same time the surfaces to be united are heated by a strong flame of a blow-pipe, produced from a gas-light or by means of an alcohol lamp. The dressing is now placed on these surfaces, and when it begins to fuse it is spread by means of a small soldering iron of aluminium. When cold the surfaces are carefully leveled by means of a file and united by annealed iron wire, and the solder is applied in a finely pulverized state by means of a hair-brush. Thus prepared the article is again placed on heated charcoal, and the flame of a blow-pipe is brought to bear on it until the solder begins to fuse, when it is divided by a slightly heated soldering-iron. A common soldering-iron of copper must not be used as the solder adheres to the same, which is not the case when the soldering-iron is made of aluminium.

To facilitate the fusing of the solder on the aluminium, Mr. Mourey uses a compound of three parts of balsam of copaiba with one part of pure Venetian turpentine, mixed together in a cup. A few drops of lemon juice facilitates the uniting of the two ingredients.

Instead of spreading this mixture on the surfaces to be united, it is found to have a better effect if the solder itself is dipped into it.

Great care should also be taken not to expose the solder to the flame of the blow-pipe any longer than necessary to fuse the same. If the heating is carried on too long, the zinc burns out and the solder becomes brittle.

## CASTING METALS IN INSULATED MOLDS.

MESSRS. EDITORS:—Having entertained the belief that a great change takes place in the electrical condition of every substance when passing from a fluid to a solid state, a mold was insulated from the ground and molten iron poured into it (the person pouring in the metal was also insulated), and the result was peculiar. The casting thus produced of common iron was white as silver and hard as cast steel. The great object of the experiment was not mere curiosity, but to discover, if possible, some improvement of practical advantage in the arrangement of the crystals of the metal, and applicable to the graining of sugar and chemical salts. The result of this experiment may have been accidental. I present the subject to the intelligent readers of the *SCIENTIFIC AMERICAN*, hoping that some of them may still further investigate the matter.

R. T. KNIGHT.

1,018 Spring Gardens, Philadelphia, Aug., 1859.

[The foregoing is part of Mr. Knight's letter. We will also give some extracts from two letters of Mr. Calvin Adams, of Pittsburgh, sent to us by our correspondent, detailing the results of experiments:—

"Yesterday (Aug. 19, 1858) I made a full trial of the insulated mold, and let it get cold before it was opened. There is something singular about it, as it makes the softest iron hard. That which I cast is as white as silver and hard as cast steel, but I don't know that it is harder than any other hard metal. We make all our castings hard for malleable iron, as soft castings will not become malleable. We sometimes have great difficulty in getting iron to run hard."

In another letter to Mr. Knight, dated Oct. 4, 1858, he further says:—

"I have been giving the insulated metal a full course of experiments, and we have annealed twice since I wrote you, and from the result I have come to the conclusion that it is 'no go,' either for soft or common castings or for malleable castings. The common metal cast in insulated molds has the appearance of refined iron—white, and to all appearance hard, just as we want it for annealing; but when it has passed through the annealing furnace it becomes the same thing as if it had been soft when put in, and it is very brittle. In annealing, the heat in the furnace will melt very soft metal. The common pig metal used for making malleable castings seems to come out of the annealing furnace just the same when poured into insulated as common molds, yet the castings in the former molds seem to be much harder."

Mr. Adams is at the head of a large establishment, which has an extensive foundry. There seems to be some peculiarity produced in metal by casting it in insulated molds, and this very fact warrants further investigation to discover the cause; hence we have published the foregoing as a matter of interest to those engaged in molding molten substances, as metals, glass, &c.—Eds.

## PRIZE FOR A DITCHING PLOW.

MESSRS. EDITORS:—A few days since I suggested to the Illinois Central Railroad Company the propriety of offering an award of \$500 for the best machine for open ditches. By the following replies you will see they have coincided in my views and made the offer. As your paper is the proper medium through which inventors know what is needed, and publish their inventions, I send you copies of the reply received from the company, and suggest to inventors that they have but a short time to spur up in.

H. HINKLEY.

Prairie Cottage, Assumption, Chris-  
tiana County, Ill., July 27, 1859. }

H. HINKLEY, M.D.—Dear Sir:—I received a day or two ago your letter of the 20th. I brought the subject before the Executive Committee to-day, and we agreed to offer a premium of \$500 for a good ditching machine. Mr. Biddle will enclose you a copy of the resolution.

GEO. B. MCCLELLAN, Vice-President.  
Illinois Central Railroad Company, }  
Chicago, July 22, 1859. }

H. HINKLEY, M.D.—Dear Sir:—At a meeting of the Executive Committee of the Illinois Central Railroad Company, held this day, the following resolution was adopted:—

"Resolved, That the Illinois Central Railroad Company offer \$500 for the best ditching machine for open drainage. The simplicity and economy of its construction and its applicability to farm uses shall be such that it can successfully compete with manual labor; the award to be made by the Executive Committee of the State Agricultural Society, in connection with three scientific machinists to be selected by that body. Before anybody shall claim payment of said award, he shall exhibit the practical working of the machine at the same places and times with the steam plow which shall receive the award from the same committee, this company agreeing to transport said machine to and from such points free of expense to the owner.

W. F. BIDDLE,

Sec'y of Executive Committee.

Illinois Central Railroad Company, }  
Chicago, July 22, 1859. }

## THE FAMILY OF HENRY CORT AGAIN.

We have on more than one occasion directed attention to the poverty of the remaining descendants of the inventor of iron puddling and drawing rollers, and have pointed out the rank injustice of the British Government in depriving that inventor of the benefits which might have been secured to him by his patents. We had thought that something effectual would have been accomplished before this time for their relief, because their case was pretty warmly espoused by the British press, but we regret to state that, in this expectation, we have been disappointed. In a copy of the *Times*, brought by the *Persia* last week, we find a letter on this subject addressed to the editor by William Fairbairn, the distinguished engineer of Manchester, with a donation of one hundred pounds (about \$500) as the basis of a national subscription, and accompanying this he says:—"It is well known that the discovery of the art of puddling, piling, welding, fagoting, and rolling iron belongs to Henry Cort; and it is also known that these processes have been carried on with great success and with great benefit to the country for the last 70 years. It is perhaps not so generally known that Cort expended a fortune of upward of £20,000 in perfecting his invention, and that he was robbed of the fruits of his discoveries by the villany of a person in a high office of government, and that, cheated and persecuted, he was ultimately allowed to starve by the apathy and selfishness of an ungrateful country. When these facts are borne in mind, and it has been ascertained that his inventions have conferred an amount of wealth equivalent to £600,000,000 and given employment to 600,000 of the working population of our

land during the last three generations, we are surely justified in referring with pride to the results of such vast importance, while we insist upon the duty which devolves upon the nation to rescue from penury and distress the descendants of such a benefactor.

There are still living one son and two daughters of Henry Cort, whose united ages now exceed 200 years, and who are destitute of the most meager comforts of life. Assuredly such a state of things should not be; in a country where charity is no boast, such claims should need no other advocacy than publicity.

The case is one for prompt and generous relief. The government should do something, but, as in many former and noteworthy cases and things, I fear the assistance from that quarter will only be tendered when it is too late."

We hope this appeal to the British public will arouse not only their sympathies, but sense of justice to the claims of these aged persons. The descendants of soldiers and statesmen are oftentimes rewarded with honors and emoluments for the deeds done by their fathers. We claim, for the descendants of inventors who have benefited their country, an equal share of public and government support.

#### A TRIP THROUGH THE COUNTRY

At this time of year every one feels more or less inclined for change of scene, change of air, or simply the excitement of fresh faces, new society and different habits. All want a break in the year—something to convince them that they are not mere business or household animals, but that they are individuals with a large capacity for enjoyment, and capable of being amused and instructed by woodland notes and the sight of farms, the sea, green fields, or wild forests. In consequence, the great question now is: "How shall I spend my vacation?" Friend, let us give you the advice which Dr. Hufeland, of Jena, gives on the subject of traveling, in his great work, "The Art of Prolonging Life," adding to his advice the determination to be amused and keep in good temper the whole holiday through. What if hotel keepers over-charge thee, friend? be not vexed, but make a joke of it, and the laugh will do you more good than the extra charge could do if spent in physic. Look on all things pleasantly, determined to be pleased, and the moral effect will be of more value than the physical; and above all, locomotive swain, take with thee at least one-third more money than you expect to spend. You can economize on the way, but it is well to have something to meet contingencies. The learned doctor tells us:—

1. Traveling on foot, or rather on horseback, is the most healthful; but when one is weakly, or undertakes long excursions, it is more advisable to travel in a carriage or by railroad.

2. When one travels in a car, it is very beneficial always to change the posture; that is, to sit sometimes and sometimes to recline. By these means one can best prevent the evils attending continued riding in this manner, which are occasioned principally by the jolting being in one direction.

3. Nature will not suffer any sudden transitions. It is therefore improper for people accustomed to a sedentary life to undertake suddenly a journey during which they will be exposed to violent jolting. The case here is the same as if one accustomed to drink water should all at once begin to drink wine.

4. Excursions, the object of which is health, must not be fatiguing; but this can be determined only by difference of temperament and constitution. One ought, above all things, to avoid traveling in the night-time; which, by interrupting the necessary refreshment, checking perspiration, and exposing the body to unhealthy air, is always prejudicial.

5. People must not imagine that they may indulge a little more in intemperance when on a journey. One, however, needs not to be too nice in the choice of food and drink; and it is always best to use the common fare of each locality. But at any rate the stomach ought not to be overloaded. By the motion of traveling, the power of the body is too much divided for the stomach to admit of a large quantity of food; and the motion itself, by these means, will become more fatiguing. People, in particular, should not indulge too much in heating food and liquors, as is often the case on journeys; for traveling alone acts as a stimulus, and less stimulating nour-

ishment is then required than in a state of rest. A want of attention to this rule may occasion too violent irritation, inflammation, accumulations of the blood, &c. It is most proper, on journeys, to eat rather little at a time, but often; to drink more than one eats; and to choose food easy of digestion, yet strongly nutritive, not of a heating nature, and such as cannot be readily adulterated. It is safest, therefore, in the country and in small hotels, to use milk, eggs, well-baked bread, boiled or roasted meat, and fruit. Drink water, with the addition of a little lemon-juice. If the water be impure, it may be rendered sweet by charcoal powder.

6. Avoid immoderate exertion and wasting of the powers. It is, however, as difficult in general to lay down a proper standard of motion, as of eating and drinking. But nature, in this, has given us a very excellent guide, a sense of lassitude, which is here of as much importance as the sense of satiety in eating or drinking. Weariness is nothing else than the voice of nature, which tells us that our stock of powers is exhausted, and that he who is tired should enjoy repose. But nature may, indeed, become lost in habit; and we may be as insensible of lassitude as the continual glutton is of fullness, especially when the nerves are overstrained by stimulating and heating food and drink. There are then, however, other signs to tell us that we have exceeded the proper measure; and I request that to these the strictest attention may be paid. When one begins to be low-spirited or dejected; to yawn often, and be drowsy, yet at the same time to be incapable of sleeping though one enjoys rest; when the appetite is lost; when the smallest movement occasions a fluttering of the pulse, heat, and even trembling; when the mouth becomes dry, and is sensible of a bitter taste, it is high time to seek refreshment and repose, if one wishes to prevent illness already beginning to take place.

7. While one is traveling, insensible perspiration may easily be checked; and cold is the principal source of those diseases which thence arise. It is advisable, therefore, to guard against all sudden transitions from heat to cold, or the contrary; and those who have great sensibility in the skin, will do well, when they go on a journey, to carry a thin flannel shirt along with them.

8. Cleanliness, when on travels, is doubly necessary; and, therefore, to wash the body frequently with cold water is much to be recommended. This will contribute also, in a great degree, to remove lassitude.

9. During winter, or in a cold climate, one may always submit to greater exercise than during summer, or in warm climates, where perspiration exhausts one-half of the strength. One, also, can undergo more fatigue early in the morning than in the afternoon.

10. Full-blooded persons, or those who are subject to a spitting of blood, or other serious disease, must consult their physician before they undertake a journey.

AMERICAN ENTERPRISE IN JAPAN.—We have received two interesting letters from our naval correspondent on board the United States steam frigate *Mississippi*, one dated from Nagasaki, Japan, April 15th, and the other Woosung, China, 18th, which we shall print as early as possible. Among many interesting items furnished by our correspondent, is information that Mr. Daniel Coombs, formerly of Charlestown, Mass., who has been engaged in the sail-making business at Shanghai for the last five years, is about to close up his business and in company with another gentleman will proceed to Nagasaki, Japan, with the intention of opening a first-class American hotel for the accommodation of our countrymen and others who may visit that beautiful port. Several other American gentlemen residing at Shanghai were on the eve of removal to the newly-opened country, to try their luck at money-making among the Japanese. *Boston Herald.*

LARGE IRON GIRDERS.—The largest iron girders that have ever been made on this continent, we believe, are about to be placed in position in the Peabody Institute, now in the course of erection in Baltimore. Their length is 69 feet, clear span 66. The roof of the Institute is to be iron and similar to those on the Custom House and Post-office of that city, the latter of which contains 15,000 square feet of surface. The iron work of the institute is superintended by Mr. Benj. Severson, an old subscriber and correspondent of the SCIENTIFIC AMERICAN.

#### THE WONDERS OF INVENTIONS.

Among the thousand marvelous inventions which American genius has produced, within the last few years, are the following, compiled in an abstract from the Patent Office Report. Read them over, and then say if you can, that there is nothing new under the sun.

The report explains the principle of the celebrated Hobb lock. Its "unpickability" depends upon a secondary or false set of tumblers, which prevent instruments used in picking from reaching the real ones. Moreover the lock is powder-proof, and may be loaded through the key-hole and fired off till the burglar is tired of his fruitless work, or fears that the explosions will bring to view his experiments more witnesses than he desires.

Doors and shutters have been patented that cannot be broken through with either pick or sledge-hammer. The burglar's occupation's gone.

A harpoon is described which makes the whale kill himself. The more he pulls the line, the deeper goes the harpoon.

An ice-making machine has been patented, which is worked by a steam-engine. In an experimental trial, it froze several bottles of sherry, and produced blocks of ice the size of a cubic foot when the thermometer was up to eighty degrees. It is calculated that for every ton of coal put into the furnace, it will make a ton of ice.

From one examiner's report, we gather some idea of the value of patents. A man who had made a slight improvement in straw-cutters, took a model of his machine through the western States, and after a tour of eight months, returned with \$40,000. Another man had a machine to thrash and clean grain, which in 15 months, he sold for \$60,000. These are ordinary cases, while such inventions as the telegraph, the planing machine, and india-rubber patents, are worth millions each.

Another examiner's report describes new electrical inventions. Among these is an electrical whaling apparatus, by which the whale is literally "shocked to death." Another is an electro-magnetic alarm, which rings bells and displays signals in case of fire and burglars. Another is an electric clock, which wakes you up, tells you what time it is, and lights a lamp for you at any hour you please.

There is a "sound gatherer," a sort of huge ear-trumpet, to be placed in front of a locomotive, bringing to the engineer's ears all the noise ahead perfectly distinct, notwithstanding the noise of the train.

There is an invention that picks up pins from a confused heap, turns them around with their heads up, and sticks them in papers in regular rows.

Another goes through the whole process of cigar making, taking in leaves and turning out finished cigars.

One machine cuts cheese; another scours knives and forks; another rocks the cradle; and seven or eight take in washing and ironing.

There is a parlor chair patented that can be tipped back on two legs, and a railway chair that can be tipped back in any position without any legs at all.

There is also a patent hen's nest, so completely arranged that the hen is constantly cheated into the belief that it has a real egg to sit upon; although the genuine deposit is carefully stowed away out of her sight.

Another patent is for a machine that counts passengers in an omnibus and takes their fares. When a very fat gentleman get in, it counts two and charges double.

There are a variety of patented guns that load themselves; a fishing line that adjusts its own bait, and a rat trap that throws away the rat, and then baits itself and stands in the corner for another.

There is a machine also, by which a man prints, instead of writes, his thoughts. It is played like a piano-forte. And speaking of pianos, it is estimated that 9,000 are made every year in the United States, giving constant employment to 1,900 persons, and costing over \$2,000,000.

[We copy the above from an exchange. It is convincing proof that romance and reality are charmingly combined in the development of inventive genius.

CLUBS.—We hope our readers will not forget the very liberal discount which we make to clubs. *No other journal of the kind in the world is afforded upon terms equally favorable.* We are much obliged to all those friends who have interested themselves in the formation of clubs, and we earnestly hope that more will enlist in this work.

### SUGGESTIONS RESPECTING RAILWAY SUPERSTRUCTURE.

The following excellent remarks on railroad construction, by John C. Trautwine, C. E. of Philadelphia, are from the *Journal of the Franklin Institute*:—

"I would suggest to superintendents of railroads now in operation, the trial of a few rods in length of superstructure with string-pieces, and two sets of cross-ties. First place in the ballast ties, 6 by 8 inches, two and a half feet apart from center to center; upon these place longitudinal sills, also 6 by 8 inches; lastly, upon the latter place the smaller cross-ties supporting the rail, about 3 by 6 inches, and two or two and a half feet apart from center to center; the bottom of the longitudinal being about an inch above the ballast. The bottom of the string-piece is supposed to be elevated about an inch above the ballast. It appears to me that the elasticity insured to the rail, *throughout its entire length*, by this arrangement, will be found to diminish to a very great extent, the destructive *pounding* action which the engines exert upon the rails of all the superstructures now in use. Experience would soon point out the proper dimensions and distances apart of the timbers to be employed for engines of any given weight, in order to insure the requisite degree of elasticity, which evidently admits of being varied to any extent which may be found desirable. The increased quantity of timber involved in this proposed plan is an evident objection to it; but experience only can indicate whether the attendant advantages which it possesses may not more than counterbalance this objection, together with any others to which it may be liable. Besides the greater presumed durability of the rail, *from the fact that no portion of it rests on a rigid support*, we should secure a much more efficient rail-joint, inasmuch as the joints would rest upon the upper cross-ties, instead of *between* the ties, as in the present preferred practice; thus combining increased strength of joint with greater uniformity of elasticity. We also should elevate the rail more beyond the influence of snow. Moreover, should this expedient enable us to obtain that certain (uncertain?) amount of elasticity of rail which all engineers concede to be so important a desideratum, it will doubtless lead to the adoption of more efficient supports for the lower cross-ties themselves—supports which may extend below the influence of rain and frost, and thus effect a very important reduction of expense for rectification of the track, besides dispensing with the use of ballast. The greatest objection in the employment of such supports, hitherto, has been the increased *rigidity of track* attendant on them, and by which the destruction of the rail is greatly accelerated. But if we can devise a means of modifying or entirely annulling this rigidity in the rail by a process *entirely independent of the foundation on which the rail rests*, then this objection vanishes; and the way seems to open for arriving at a much more perfect superstructure than has hitherto been used.

I hope that the subject may be regarded by some of our intelligent superintendents as being of sufficient interest to induce them to make a trial of it, if only for a few lengths of rail."

### SOMETHING LIKE EATING

At the late Handel Festival at the Crystal Palace, Sydenham, England, which was attended by 80,000 persons, eating and drinking would seem to have been one of the principal enjoyments, if we may form an opinion from the amount consumed, which some industrious reporter has been at the trouble to discover and give to the world as a specimen of British capacity for nutriment.

"We find," says the item, "that during the festival the consumption of creature comforts was something as follows:—1,600 dozen sandwiches, 1,200 dozen pork pies, 400 dozen Sydenham pastries, 800 veal and ham pies, 650 pigeon pies, 480 hams, 3,509 chickens, 120 galantines of lamb, 240 fore-quarters of lamb, 150 galantines of chicken, 60 raised game pies, 3,022 lobster salads, 2,325 dishes of salmon mayonnaise, 300 score of lettuce, 41,000 buns, at two cents each; 52,000 do., at four cents; 32,249 ices, 2,419 dozen 'beverages,' 1,150 do. ale and stout, 403 Crystal Palace puddings, 400 jellies, nine tuns of roast and boiled beef, 400 creams, 350 fruit tarts, 3,500 quarts of tea, coffee and chocolate, and 485 tongues. The consumption of wines, which was enormous, had not been ascertained when our account was made up."

### DIRECT-ACTING STEAM CRANES.

We copy from the *Practical Mechanics' Journal*, of London, an engraving of the invention of R. Morrison of Newcastle-upon-Tyne, England, which is a direct-acting steam crane. The wire rope is attached to the piston in a steam cylinder A, placed underneath the ground and the pressure of steam in the cylinder against the piston elevates the bucket. The crane can turn freely in any direction, and is as suitable for lowering as raising. The dotted lines in the engraving show another position in which the cylinder may be placed; in fact for convenience this crane seems to be vastly superior to the majority of steam cranes in use, which employ a steam engine and working apparatus, and compared with the hydraulic crane, from experiments made with both, it seems that the water pressure being fifty pounds and costing four-

doses, and sweet oil *ad libitum*. If the patient does not lose his presence of mind, these can be administered in a saucer, from which he can sup without coming in contact with the edge. Should the contrary be the case, other means must be resorted to.

The above remedies should be followed by prompt and active emetics till the stomach is entirely emptied of its contents. To illustrate the danger of allowing anything to touch the teeth, I will state that after having so far recovered from the effects of an accidental dose, as to be able to sit up and chat and laugh (I could not stand,) I put my finger down my throat to assist vomiting by titillation, when my teeth instantly closed upon it, cutting it severely. Two desert spoonfuls of mustard mixed in warm water, in the absence of a more efficient emetic, is a harmless one in all cases ready at hand. In conclusion,

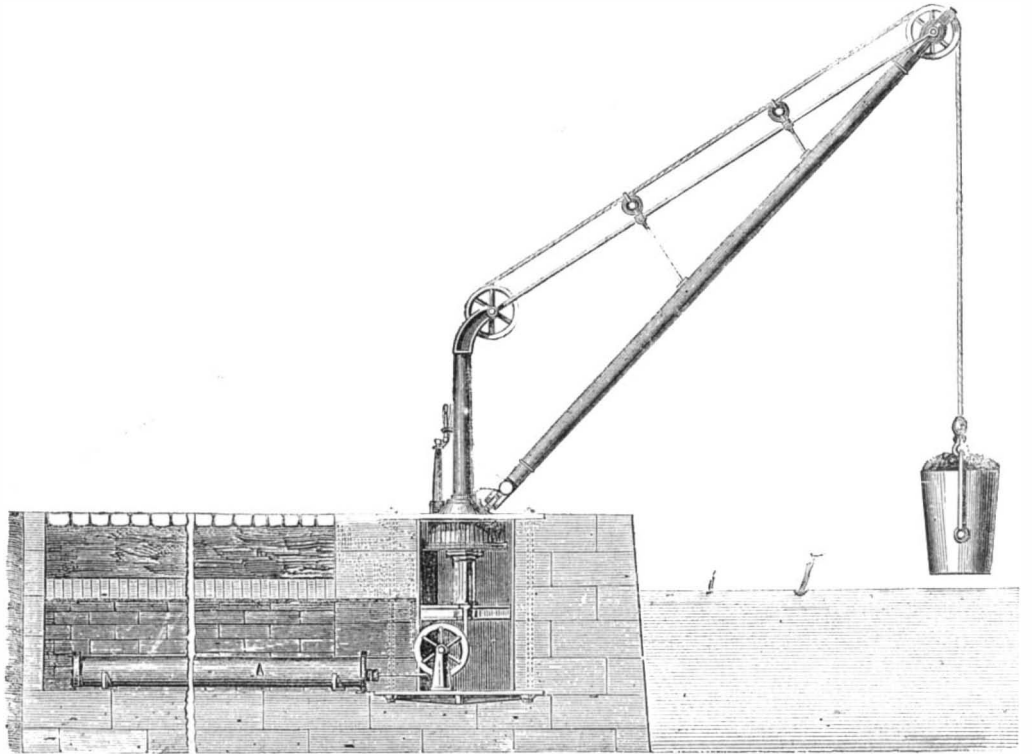

NEW STEAM CRANE.

teen cents per 1,000 gallons, the cost of such a crane was two dollars per hour; while this steam crane, using steam at a pressure of thirty-five pounds and coal at five dollars a ton would not cost more than twenty cents an hour.

### POISONING WITH STRYCHNINE.

A correspondent of the *Dispatch* (this city) gives the following very useful information in regard to the above very terrible poison:—"The action of this poison commences with a tingling sensation in the feet, gradually rising to the knees, thighs, trunk, arms, jaw and head, the muscles becoming rigid, and the effects increasing in strength, till all the organs are perfectly paralyzed, the eye-sight and brain being the last affected. In my own case, although I had a narrow escape, my reasoning powers and eye-sight were under my complete control. Between the spasms I was seeing, thinking, breathing statue. In cases of poisoning with this drug, care should be taken that the patient does not throw his head backward. The best position is to have the patient seated in a chair, with his head resting on a table, the arms dropping by his side.

In administering any remedy great pains should be taken that the article containing it should not be allowed to touch the teeth, as if it be a spoon or other similar hard substance, they will immediately close upon it, and tetanus (or lock-jaw) ensue, or if glass, a piece will be instantaneously bitten out of it, to the great danger of the patient.

Neither should any one be allowed to touch the patient if it can be possibly avoided, the effect being similar to that of a galvanic battery, and if the contact be long continued, would bring on renewed spasms, even after relief had been partially afforded.

The most available if not the surest remedies are a strong solution of camphor dissolved in alcohol, in liberal

waste not one second in securing the services of an able physician."

### BOLTING-CLOTH BUGS.

A correspondent, writing to us from Cumberland, Md., desires us to call the attention of our readers to a remedy for preserving the bolting-cloths of grist-mills from the attacks of the small black bug which is so destructive to them. He inquires if any of our millers have ever made their bolting-reels of cedar or other odoriferous wood; and if so, with what results?

Some kinds of wood, by their odor, repel the attacks of insects; but whether any of this kind of timber has been used for repelling the bug referred to or not, we do not know. Perhaps some of our readers engaged in the milling business can furnish useful information on this subject.

### ARTIFICIAL LIGHT IN PHOTOGRAPHY.

A correspondent (F. H. Baker) of the *London Mechanics' Magazine* recommends the employment of violet-colored artificial light, to be used in taking photographic pictures. He says:—"The blue rays, and especially the violet, possess the greatest proportion of the photographic principle. Why, then, is not this light made use of? Such a light would be extremely powerful as a photographic agent, while its low illuminating and heating power would admit of its being used in a very high degree of intensity, without causing discomfort to the sitter or operator."

THE electrotyping of each number of the SCIENTIFIC AMERICAN will ensure to our readers a complete volume, as we shall be enabled to supply all orders, not only for back numbers, but also those that miss their destination through the carelessness of the mail. It should be borne in mind by all that we make no charge for extra numbers supplied in the place of missing ones.

A COLUMN OF INTERESTING VARIETIES

The books in the library belonging to the British Museum occupy 12 miles of shelf.....The painting and sculpture galleries of the palace of Versailles extend over six miles.....In the course of three and a half years 270,000 trees were felled in order to get at the gutta-percha.....The eyes of needles are punctured by a machine which, superintended by one boy, can punch 20,000 in a day.....A ray of artificial light travels at the rate of 70,000 leagues in a second of time.....Astronomers have given the rate of solar light at 192,500 miles a second.....In the formation of a single locomotive engine there are over 5,000 pieces to be put together, and these require to be as accurately adjusted as the works of a watch.....Every watch consists of at least 202 pieces, employing probably over 200 persons, distributed among 40 trades—to say nothing of the tool-makers for all these.....Gas-lighting was unknown in 1800; it was not until two years after this that Murdock made his first public exhibition of it in London. Since that time his discovery has encircled the globe. In Europe and this country all the principal cities and many large towns are lighted with it; and even New Zealand villages, where no white man had built his residence in 1800, are now illuminated by the same subtle and beautiful agent of human comfort and happiness.....Every pound of cochineal contains 70,000 insects, boiled to death; 700,000 pounds are annually used for scarlet and crimson dyes.....The odorous matter of flowers is inflammable, and arises from an essential oil. When growing in the dark their odor is diminished, but restored in the light, and it is strongest in sunny climates. The plant known as the *fraxmella* takes fire in hot evenings by bringing a flame near its roots.....At present there is no really successful ventilating and dust-excluding apparatus combined for railroad cars. Much ingenuity has been displayed, and many patents have been issued for devices for these purposes, but as yet the system needs to be perfected.....The national road over the Cumberland mountains is more extensive and durable than the celebrated Appian Way at Rome.....To find the contents of a cask in imperial gallons, gage the bung diameter and multiply its square by 2. To the product add the square of the head diameter, and multiply these by the inside length. Then divide the last product by 1,089 for imperial gallons.....The Julian aqueduct of Rome is two miles longer than the Croton aqueduct of New York, but the Croton carries more water than all the seven aqueducts of Rome put together, and more than any other aqueduct in the world, and is longer than any other, excepting the Julian.....The Illinois Central Railroad is the longest line ever constructed by one company, and in point of workmanship is equal to any European road.....The stone arch over Cabin John's Creek, on the Washington aqueduct, is about 50 feet greater than any other stone arch in the world, and is more beautiful in proportion than the arch over the Oca, in Italy, so long celebrated for its magnificence.....The tunnel on the summit of the Pennsylvania Railroad was a more difficult work than the tunnel under the Thames.....The structures on the Baltimore and Ohio Railroad, at Harper's Ferry, and the Starrucca viaduct on the New York and Erie Railroad, are equal in magnificence to anything Brunel ever did in England, or Moran in France.....The suspension bridge over the Niagara river, at Lewistown, is 1,042 feet 10 inches in one span, and 43 feet greater than any other single span in the world, being nearly twice as great as the celebrated bridge over the Menai Straits in England.....The United States Dry Dock, in Brooklyn, is the largest dry dock in the world, by many feet. The plates of iron used in the gates of this dock are the largest that had been made up to the time they were rolled.....The estimate originally made by the Belgian engineers for the wear of rails upon their lines, was 120 years. At present ten years is not under the average life of rails, whilst many are actually so much worn in 12 months as to be no longer fit for use.....Boiler explosions are always reported, but simple ruptures, which often occur from over-pressure, and with no further consequences than the loss of steam and local injury to the boiler, are seldom publicly reported, and there are many who are not aware that such casualties ever happen.....The bark of trees is generally thickest on their northern sides.

IMPROVED MILLSTONE BALANCE.

This millstone balance was patented by the inventor, John Fairclough, of Louisville, Ky., Dec. 21, 1858, and has been re-issued this week, and the invention allows a stone to be balanced both as regards its gravity or weight, and the centrifugal force generated by its rotation. Our engravings illustrate this invention, Fig. 1 being a section through a millstone so balanced, and Fig. 2 a view of the top of one of the balance boxes. A, represents an upper millstone in which there is an eye, *a*, for the bail, B, and C is the driver, placed on a spindle. The lower end of the spindle is stepped in a box, E, that rests on a bridge-tree, F, which can be adjusted by a screw, G. In the upper surface of the stone A, recesses, *b*, are made to receive round metal boxes, H. These boxes are fitted in the stone near the periphery, and four may be used at equal distances apart. The boxes each have a cap or cover, *c*, which is secured to them by screws, *d*. The boxes H, have each a metal cylinder, I, within them considerably shorter than the boxes, in order to allow them to have a proper degree of adjustability. The

by the plates *h*, which will prevent them slipping.

The inventor has patented his invention in England, and he will be happy to furnish any further information upon being addressed as above.

THE BANK OF ENGLAND.

"The buildings cover about three acres of ground. Many of its rooms are copied from the classic models of Greece and Rome. The employes number about one thousand. Several of the officers reside in the bank. The notes redeemed each day are checked, canceled and put away in boxes. After keeping them ten years they are burned. The accumulation of the last ten years, now in the vaults of the bank, amount to three thousand millions of pounds; and yet any one of these notes can be referred to in a minute, and the history of its issue and its return given. The bank does all its own printing; and several presses are kept busy. Everything is done by machinery—the note is not touched by the pen before it goes out. I held in my hand, yesterday, one note for a million of sovereigns!

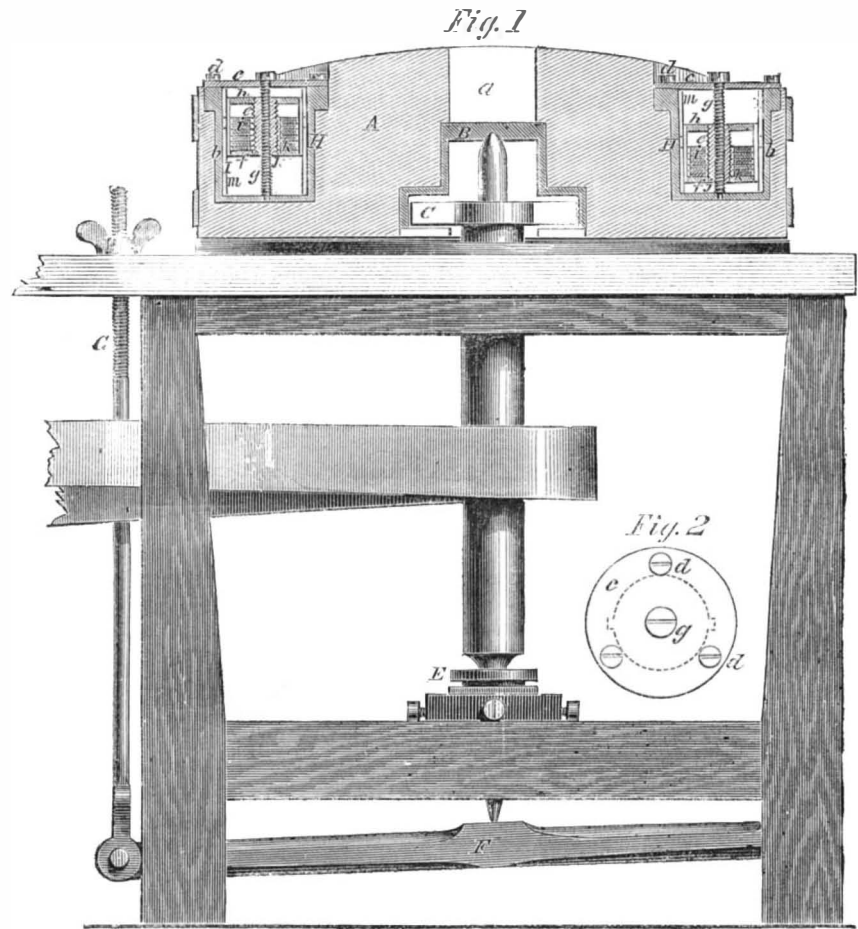

FAIRCLOUGH'S MILLSTONE BALANCE.

cylinders I, have each a tube, *e*, running through them, connected with a cross-bar, *f*, at the bottoms of the cylinders. The tubes, *e*, have screw threads cut on them, both inside and out, and a screw, *g*, passes through each tube and the cap, *c*. In the upper part of I, a plate, *h*, is fitted, and these are screwed on the tubes, *e*, and in each cylinder is a series of weights, *i*. The bottom, *j*, of each cylinder rests on nuts, *k*, fitted on tubes *e*. The cylinders I are provided with two projections which fit in grooves or slots, *m*, in H, and which serve as guides to I. From this description it will be seen that the stone A, may, so far as its gravity is concerned, be readily balanced on the spindle by the weights *i*, more or less being placed in each cylinder, but by doing this it will be observed that when the stone is rotated, lateral pressure and an undue degree of friction will be caused on the collar of the spindle by centrifugal force, and to remedy this difficulty the cylinders I are made adjustable and raised or lowered by the screws *g*, and the center of gravity of the weights may be adjusted relatively with the point of the spindle, so as to neutralize this unequal centrifugal force. If but few weights are in a cylinder it requires to be elevated so as to increase the distance between the point of the spindle and the center of gravity of the weights, and *vice versa*. The weights may always be retained in their proper place

In the bullion-room ingots of gold were piled up like cords of wood, and silver bars in vast mountains. The machines for detecting light coin, and for cutting them, are exceedingly curious and yet simple. Every banker's deposit is weighed, and all the light pieces cut nearly in two and returned next day. The system of the bank is as perfect and as exact as clock-work. And yet in spite of all precaution, some small forgery is almost daily detected. But since the great forgery committed by Axtell for £360,000, the bank has not lost any very heavy sums; although in 1822 capital punishment for the crime was abolished, when the 'old fogies' predicted that everybody 'hard up' would turn forger.

In the specie department of the bank there are bags and boxes of sovereigns and half-sovereigns enough to make a miser mad; there are mountains of Mint drops, for which millions are sighing and lying, and perpetrating all conceivable crimes! I was asked to lift a big bag of sovereigns, and for once, I must confess, I felt a sovereign disgust for money."—Col. Fuller.

PORTFOLIO PAPER FILES.—We are indebted to Mr. J. N. Jacobs, of Worcester, Mass., for a very convenient portfolio for holding the numbers of the SCIENTIFIC AMERICAN. It is a good article for the purpose.

### A VISIT TO THE PATENT OFFICE AT WASHINGTON.

[Correspondence of the New York Herald.]

A visit to the Patent Office at Washington is well worth a trip to that city if there was nothing else to attract attention. The building is one of the most beautiful in the world, occupying two entire squares, the noble front being a *fac-simile* of the Pantheon.

The grand entrance is by a flight of granite steps leading into the vestibule, which contains a splendid and unique double flight of marble steps, which astonish the visitor unacquainted with architecture, being suspended in air and supported and held up because they form a horizontal arch. Upon entering the second floor we perceive an immense hall, 264 feet long by 64 feet in width, and high 30 feet, ornamented with a quadruple row of massive stone Doric columns rising with their entablature twenty feet, above which spang a series of vaulted ceilings ten feet higher, covering the whole area and forming a highly ornamented plafond. In the center of this gallery a grand cylindrical arch of forty feet span towers above the rest. This was not the first design of the architect, but circumstances arose which compelled him to change the plan, which produced a blemish that may hereafter be remedied. This hall contains the collections of the National Institute and rejected models. The curiosities that have been collected during the past forty years, and also many of the early reminiscences of the government are deposited here—the press of Franklin, the coat of Jackson worn at the battle of New Orleans, a model of the Bastille, presented by the son of Lafayette, and fragments of the Peacemaker, which deprived the country of the services of two members of the Cabinet and other distinguished individuals.

At the lower end we come to the machinists' room, to the right of the entrance to the great model room. This contains about 25,000 patented models, all arranged in ninety-six cases. These are divided into twenty-two classes, and are readily found with the assistance of a catalogue just published by Mr. Hunter, and sold in the vestibule. Visitors from all parts of the States and Europe are found examining these models. The cases are kept in admirable order, under the charge of Mr. Bell, the machinist. The property invested in patents is enormous, and the profits of a successful invention are very great.

The new Commissioner, Mr. Bishop, of Connecticut, has taken his seat, and with the aid of the twelve examiners and assistants, the operations of the office work smoothly and efficiently. Nearly one hundred patents are granted weekly. It is supposed that upon an average every patent nets to its owner \$50,000. This is the opinion of one of the examiners who long had a desk in the Office, but who gave place to another gentleman upon the change of administration. This room also contains curiosities collected and belonging to government—the Declaration of Independence, the commission of Washington, the sword he wore in his campaigns, the uniform worn at Annapolis when he surrendered his commission, his old camp chest (it looks war-worn and hardly worthy of the leader of our armies, even of the Revolution)—the old tin plates—he says in his invitation to Mrs. Livingston to dine with him—"once tin, but now iron;" they have the same appearance now they had then. There are also the treaties with the foreign governments deposited here; here are the treaties with Louis XVI., the Directory, Napoleon, Louis Philippe, the Georges, and others of equal note.

The new hall in the west wing is just completed and for architectural beauty surpasses anything of the kind either in the Old or in the New World. It is intended to contain the rejected models, of which there are about 70,000, each of which costs the inventor not less than \$50, and so on up to \$800—an enormous amount of money—which, taken in connection with the anxiety of mind, caused by delay and hope deferred, would lead one to suppose some remedy could be devised to prevent such a waste of time and money. Congress last session thought something was wrong, as a bill was brought in by Mr. Seward for a publication of all rejected cases, with the reason of their rejections; it is supposed that this was preliminary to further legislation upon the subject. The copyright works are also being removed to this room and are now being arranged systematically and in order.

I would call the attention of publishers of engra-

vings who have copies deposited here, to the fact that they are now placed in a roll entirely out of sight. If they were handsomely framed, I have no doubt the Secretary would allow them to be placed upon the walls, as is done in London and Paris. Here these fine engravings would be an additional attraction, as well as profitable to the owners, who would find purchasers in some of the thousand visitors who here lounge away their idle hours during the Congressional season. The east wing contains the office of the Hon. Jacob Thompson, Secretary of the Interior, with the numerous clerks attached to that department; also the amiable Chief Clerk of the Patent Office, with the Pay Clerk, withdrawal and numerous officials in the various departments of the Office.

Below, in the basement, are copying clerks of the Patent Office, depositories for the models, where they are arranged and labeled prior to being placed in the examiners' hands. The Indian Bureau here has its offices and archives, employing a numerous force under the able superintendence of its chief clerk, Mr. Mix. There are few changes made in this department, and some of its members have been attached to it for years. Mr. Dowling, born and brought up a printer in Washington—one of its most efficient attachés—is much respected by the community.

On the floor leading to the west wing are situated the library and draughtsman's room. The library contains perhaps the most valuable collection of scientific works in the world. There is no work upon any subject of science or mechanics but may be found here, even to the advertising card of a New York stove manufacturer, which has been found here to be in the way of some unfortunate inventor, to the ponderous and valuable publications of the English Patent Office. The librarian, Mr. Turner, speaks several languages and is an author himself, having assisted in the compilation of some of the most profound works issued by the Smithsonian Institution.

The draughtsman's room, under the able superintendence of Mr. McIntyre, is a model of order. Here are arranged the drawings of upwards of 75,000 inventions, all arranged and classified so that any one wanted can be furnished in a moment. Here also all the specifications of applications yet pending are deposited.

The record room, in charge of Mr. Dorsey, claims attention. Copies of specifications of patents, assignments, &c., carefully copied off in large folios for convenience of reference, also original specifications of cases that have been withdrawn, are found in this room. Large tables are here seen, surrounded by keen patent agents and anxious inventors, searching to me after to me, fearfully but carefully investigating cases that have been patented. Sometimes years of hope are blasted in a twinkling; at others patient toil and thought receive new vigor with the prospect of coming independence, on finding the field of invention still open to them, and not closed by a previous invention. Farther on, on this floor, is the Land Office. This is a very important bureau, and many clerks and agents are employed from Maine to California, all centering here. There are eighty registers and receivers, some of whom receive a commission on moneys entered at their offices; others a stated salary of \$3,000.

A Commissioner, Chief Clerk, Recorder, Draughtsman, &c., receive from \$1,600 to \$3,000. In the Patent Office, examiners-in-chief, \$2,500; assistants, \$1,800; watchmen, clerks, &c., same as the others; copying clerks who make copies of specifications, patents, assignments, &c., for the use of courts and for the information of inventors, ten cents a hundred words. Of these there are about twenty. Here is also the Agricultural Department, under the superintendence of Mr. Brown, who is in daily receipt of letters from all parts of the country in regard to agricultural interests.

The report for the year is nearly completed, and will be soon ready for distribution, of which there are 212,000 copies printed, at a cost of about 60 cents each. Each member of the House receives 800 copies for his constituents. Some of them do not take the trouble to mail them, while others purchase them and distribute them also with their own. The Agricultural Bureau employs about six or eight clerks, and at times 100 boys and girls in putting up seeds, of which there are millions of bags put up and distributed. The basement of the west wing is occupied by the clerks of the Land Office; and there remains the north wing, now slowly being con-

structed. It is said the interior of the square will be paved with glass. The whole number of officials about the building is 283, to which may be added as many more attached to the department elsewhere.

### MAKING BUTTER.

As this is the season when most butter is made, some useful directions for making and treating it will not be out of place. In the transactions of the Ohio State Agricultural Society, we find some remarks on the subject, which are worthy of wide spread circulation.

*Churning.*—The cream should be brought to the temperature of from 62° to 65° Fahr. and churned. Experience has proved that such a stroke of the churn dash as will bring the butter in about thirty minutes, makes the best. At a temperature of about 62° Fahr., from fifty to sixty strokes of the dash per minute will accomplish this result, if care is taken to strike the top of the cream and the bottom of the churn at every stroke. If the churn be filled so that the dash cannot strike the top of the cream, the operation can scarcely be accomplished at all. Rapid churning should be avoided at the commencement, though the motion may be accelerated after the cream curdles. The butter, when sufficiently gathered by churning, should be transferred with a wooden ladle to a wooden bowl.

*Making the Butter.*—After the butter is taken from the churn, it should be skillfully worked until nearly all the milk is out of it. And here arises the mooted question, whether cold water should be used in the process; whether the butter may be washed? Experience has proved that if the milk can be expelled without water, the taste of the butter will be superior; but the buttermilk must be expelled at all events; and a free use of cold water will more certainly and speedily accomplish this object than any other means; and all other things being right, water-washed butter will be very good. The keeping quality of butter without washing is thought by many to be the best.

When the buttermilk is pretty well worked out, such a quantity of salt should be added as suits the tastes of those who are to be its consumers. Some give seven-eighths of an ounce of salt to a pound of butter as a rule; it should be thoroughly incorporated with the butter at its first working. The butter must be subjected on the ensuing day to a second working; these two may suffice for present consumption, but for butter, intended to be kept, a third working on the third day will be necessary. A machine butter-worker will very much aid in the second and third workings. The great cause of butter becoming rancid is milk left in it, therefore unless it is entirely removed, the butter will soon become miserable in quality.

*Packing.*—For keeping butter, for family use, no vessel is preferable to earthenware crocks. In these pack the butter in layers of such thickness as will be convenient for use; sprinkling a little salt between each layer, for convenience in extracting the butter for use. Continue until the crock is nearly full; then cover with a fine muslin cloth, on which place a layer of salt half an inch thick; then fill with strong brine, and cover with a lid, and the work is done.

### NEW VENTILATING HATS

A few weeks since we directed attention to the above subject, and in our list of claims this week it will be perceived that a patent has been granted to William F. Warburton, 430 Chesnut-street, Philadelphia, for a hat embracing the improvement which we had stated was necessary to render a hat perfectly ventilating. The hat is porous, having its sides perforated with numerous small holes by a machine containing heated points, and it also has a few minute openings in the crown, so that a current of air is permitted to circulate through it. The perforations are so small that they cannot be seen with the naked eye, except upon close inspection, and they do not weaken the sides of the hat, because none of the material is removed in making them. We have examined one of these hats, and consider the invention exceedingly useful and original; and the principle should be applied to every hat which is stiffened with varnish.

An American company from Minnesota have started a steamboat on Red river, in the British settlements, and they will undoubtedly reap the advantages of a large summer business.

**THE AMERICAN ASSOCIATION FOR THE ADVANCEMENT OF SCIENCE.**

That respectable body of scientific persons who meet annually for the purpose of ventilating their opinions on various highly interesting subjects, assembled on the 3d inst., at Springfield, Mass. The first business would seem to have been a convention among those savans who are anxious for distinction by having a string of capital letters after their name; and as the present name is too long, and A. A. S. would not look particularly well as a tail to "Professor," it is proposed to change the name of the association to the "American Scientific Society." Shade of Dr. Pangloss, where art thou? A. S. S. The greatest acme of a learned man, "to write him down an ass."

The last paper read before this eminently practical body was by Professor Pierce, on "The Theory of the Tail of the late Comet." Poor comet; why not let him wander away in peace? In the evening, the usual festivity. The second day, some very abstruse papers by professors of renowned fame, which are reported in the daily press nearly at full length, and two or three by small gentlemen whose names the world has never heard on subjects of practical importance, and of which only the titles are given. Such was a paper on the "Pot-holes of Wisconsin," by Charles Whitlesey, who seems to be frozen up by the amount of glaciers that preceded him and the ice well that followed. And so it will go on, a nice, quiet, mutual-admiration society, and nothing more, without some scientific Luther dashes in among them, and frightens them into practical activity and useful life. Would that we had a Faraday, an Arago, or a Murchison among us; some one who believes that the value of knowledge depends entirely on the benefit it confers on the world at large, and not on the prestige it gives the possessor amid his limited circle of acquaintance.

We are glad that Uriah Boyden, Esq., the improver of the turbine wheel, is at the meeting, as he is an eminently practical man, and we shall expect to have something of real importance from him.

The subjects which have been discussed up to the second day thoroughly prove our position, and we cannot do better than give the titles of a few of them. After the comet's tail had wagged through the meeting, Prof. Alexander read a paper on the mass of the moon. Prof. Bache offered a discussion of some observations of magnetic declination and variation, made by him at the Girard College Observatory, from 1840 to 1845. A paper on ocean currents, by Captain Wilkes. Observations on ozone, by Prof. Brocklesly; on the earth's measure and the French meter; the mathematical theory of music; a new method of investigating short curves; on the platinum metals; observations for temperature at Van Rensselaer harbor; atmospheric pressure at the same place; direction and force of the wind at the same place. And this was two day's work of the mathematical section!

The natural history section opened with a paper by Prof. Hitchcock, on the ancient glaciers in the Green Mountain range, followed by a discussion. The paper we have previously alluded to followed. Then Prof. Hitchcock, on the frozen well, in Brandon, Vt. The same gentleman was next felicitous on pebbles; Prof. Whitney was learned on the bones and teeth found in the lead-bearing crevices of the northwest; and Prof. Dawson read a paper on the coal-plants found in the lower domain of Canada.

In the evening, a *soiree* at which Governors Banks and Morgan were present. In short, the whole is very learned in the day-time, and very jolly at night; and we think that their night's play is better than their daily work.

The third day was more interesting, in a practical point of view, than either of the preceding; and next week we shall be able to give our readers some information culled therefrom.

**BOSTON MECHANICS' TRADES' SALE.**—A great sale is announced to take place in Boston, on the 16th of this month, of articles furnished by inventors and mechanics, and which are to be on exhibition at the rooms Nos. 41 and 43 Summer-street, for several days previous to the sale. This will afford an opportunity long desired by the mechanics and inventors of New England to bring their productions prominently before the public.

**FRICITION MATCHES WITHOUT PHOSPHORUS.**

Phosphorus in friction matches is very hurtful to the health of the manufacturers, owing to its poisonous character, and a substitute has been frequently sought. According to *Dingler's Polytechnic Journal*, a discovery has been made which obviates its use, and by this process matches are now made in Paris by M. Canouil, which are, it is stated, ignited by being rubbed on a hard body, whether it be rough or smooth. Neither a blow, nor a shock, nor a temperature of 356° Fah., are capable of igniting these matches; their combustion is only caused by friction.

The following are three recipes for making these matches, which are said to be very safe:—

Dextrine .....	10 parts.
Chlorate of potash.....	75 "
Brown oxide of lead.....	35 "
Iron pyrites.....	35 "

Water—the quantity necessary to form a uniform paste.

The chlorate of potash, the oxide of lead and iron pyrites are separately powdered, and then made into a paste by means of the solution of dextrine; into this the ends of the sulphured matches are dipped in the usual way. The dextrine might be replaced by gum or glue, and the iron pyrites by other metallic sulphurets, to some of which, however, it is preferable as not being poisonous.

A second patent of Canouil's, dated October 7, 1857, relates to safety-matches of wood, wax, paper, German tinder, &c., which ignite only at a particular surface, containing no phosphorus. The latter consists of a slip of wood, card or metal, covered with a layer of the preparation, which causes the ignition of the chemical match by mere friction. Such matches may be sent anywhere without the least danger, as the matches and the friction-surfaces may be packed in separate boxes. The mass for the matches consists of—

Chlorate of potash.....	7 parts.
Acetate of lead.....	2 "
Bi-chromate of potash.....	2 "
Flowers of sulphur.....	1 "
Gum or dextrine.....	6 "
Water.....	18 "

The covering for the friction-surface consists of—

Iron scales.....	1 part.
Emery.....	1 "
Chlorate of potash.....	6 "
Minium.....	1 "

Size—a sufficient quantity to form a paste, which is applied to a slip of card, wood or metal.

The substances are made into paste, as described for the first matches.

In order to avoid the slight explosions which occur on the friction of the first matches, the metallic sulphurets are left out, and are replaced by powdered glass or flint, which is mixed in various proportions with the chlorate of potash, according as it is desired to produce combustion with more or less ease by friction. Bi-chromate of potash is also added as an oxydizing body.

The new mass for sulphurated matches consists of—

Chlorate of potash.....	5 parts.
Powdered glass or flint.....	3 "
Bi-chromate of potash.....	2 "
Gum or dextrine.....	2 "
Water.....	8 "

**INTERESTING EXPERIMENT IN ELECTRICITY.**

**MESSRS. EDITORS:**—There are few experiments in that interesting subject, electricity, that can be successfully practiced by the young, on account of the expense attending them and the apparatus required to perform the experiment; but I give below a very interesting one, which, I believe, originated with myself, and which can be performed by any trio having in their possession the simple articles named. Procure four glass tumblers or common glazed teacups, and having wiped them dry as possible, hold them over the fire to evaporate any moisture which may still adhere to their surface; for if there is the least moisture it makes a connection, and spoils the experiment. Place them upon the floor in a square, about one foot apart, place a piece of board upon the tumblers, and have a person standing upon the board. This person is now completely insulated, the glass being a non-conductor of electricity. Now take a common rubber comb, and having wound a piece of silk around one end of it, rub it briskly through your hair, and draw

the teeth parallel to the insulated person's knuckles, leaving a little space between the comb and the person's hand. The result will be a sharp, crackling noise, and, if dark, there will be seen a succession of sparks. Repeat the process until the phenomena ceases. The person is now "charged" with electricity, the same as a Leyden jar. To draw off the electricity, approach your knuckles to the person's hands or his nose (being careful not to allow any portion of your body to come in contact with his), and there will be a loud snap and the sparks will be very brilliant. If a cat be held so that the charged person can place his knuckles in proximity with the animal's nose, it will suddenly appear as if it were in contact with an electric-battery. A glass bottle may be used in lieu of the comb, but is not so well adapted for the purpose. Much amusement may be derived from this extremely simple experiment, and I hope some of your numerous young readers will hasten to try it for themselves.

S. H. GREENLEAF.

Newark, N. J., August 1, 1859.

**NEW YORK AND ERIE RAILROAD.**

As a commercial enterprise, this railroad has turned out a great failure. It has become bankrupt, and its shares have fallen to five per cent. A judgment was recently obtained against it for \$55,000 on sinking-fund bonds, and an execution was issued. As the interest on its mortgages have not been paid for some time, steps have been taken to foreclose them. A motion was made by some of the holders of mortgages on the 2d inst., before Judge Mason, at Norwich, N. Y., to appoint a Receiver for all the property of the company, with power to run the road and pay all the operatives and the interest on mortgages and other debts. The motion was not resisted, so this railroad must now go down in the valuation of its property. The total cost of it, for equipment, &c., was \$33,742,000. In all probability it will come into the possession of a small number of wealthy men for one-half this amount, and they will be able to run it afterwards at an immense profit.

During the last few years, it is asserted by those who seem to know something about its affairs, this road has been most miserably managed; that its expenses have increased, while its income has diminished. It is well-known, we believe, to many persons, that very able superintendents and engineers have, at various times, been connected with this railroad, but they have always been trammelled with the nepotism of directors who were incapable of appreciating true merit and ability, when it crossed the path of their family interests.

**KANSAS GOLD.**—The latest news from the Kansas gold region are encouraging. The mines are said to be yielding very well, but great difficulty was experienced in washing the deposits, for want of water. What a territory of contradictions Kansas has been! First, we had news of gold from Pike's Peak; then the second news was that the first was a humbug; now the humbug turns out to be a genuine *gold-bug*. Verily, wonders will never cease.

**MOWING MACHINES.**—Notwithstanding the immense number of these machines which have been manufactured, and the large fortunes which have been realized by their inventors, still the demand is regularly increasing. They are to be seen at every railroad depot throughout the country, and yet probably at this time there is not one farmer in fifty throughout the Union who has ever seen a mowing machine in use.—*Working Farmer*.

**MESSRS. MUNN & Co.** have, for a long series of years, been engaged in the transaction of patent business, and, during their extended experience, have had thousands of models forwarded to them by express and other modes of conveyance; and it is a fact worthy of note that they cannot call to mind a solitary case where a model has been lost beyond recovery. Inventors are thus insured beyond a reasonable doubt of the safe arrival of their business to our hands.

**BACK NUMBERS.**—We are now engaged in reprinting the Nos. 1, 2, 3 and 4, and shall send them, without delay, to all such subscribers as have not received them.

IMPROVED SAWING MACHINE.

Much time is lost with circular saws in "gigging back" the stuff after one slab has been cut from the lumber, and the machine which is the subject of our engraving saves this time by cutting the lumber in whatever direction it is moving. It has also a trimming saw, so that edging or slitting and trimming may be performed at one operation.

In our illustration, which is a perspective view, A is the flooring of a mill in which the machine is placed, and B is an elevated frame-work on which rollers, *a*, are placed and allowed to move freely. These rollers may be grooved around to receive a projecting ledge on the under side of the feed table, C, which is formed of two pieces secured at one end by a yoke, *d*. D is a circular saw which is fitted on a mandrel, placed in a suitable frame in the center of the frame, B.

On the floor, A, a frame-work, F, is raised to some distance above the saw, and a pendant frame, G, is attached to it by a joint carrying a spout, H, that is placed obliquely, the largest end facing the saw and the smallest end projecting some little distance over the side of the feed table. The spout, H, is a little above the saw, and at one side.

In the upper part of the frame a drum, I, is placed parallel to the mandrel of D, and depending from F is a frame, *g g*, which form guide-bars for a carriage, J, from which two hangers, *e e*, fall and form bearings for the mandrel, *f*, and saw, K, which is at right angles to the saw, D, which is driven by a belt, *h*, from mechanism below the flooring. The saw, K, is driven from I by a belt, *i*, the drum, I, receiving its motion from the saw-mandrel by a belt, *j*.

The operation of the machine is as follows:—In edging and trimming the attendants place the piece of lumber to be operated upon one part of the feed table, C, the feed table being at the end of its movement at one side of the saw, and the attendants adjust the stick on the table in a proper relative position with the saw, so that the latter will cut one edge of the piece of lumber. The feed table, C, is then moved by hand towards the saw, D, the latter entering the lumber, and when the end of the stick reaches a point opposite the saw, K, the feed table, C, is stopped and the carriage, J, is drawn along by hand between the guides, *g g*, and the saw, K, trims off the end of the piece of lumber at right angles with its sides. The saw, K, is then allowed to return back, by a weight or other means, to its original position, and the table, C, is again moved forward, the edging saw, D, operating as usual, and when the feed table has passed to the opposite side of the saw and one side of the lumber edged, it is turned on the other part of the table, so that its opposite side will be adjusted to the edging saw, D. The piece of lumber is then again moved toward the saw in the opposite direction, and when its untrimmed end reaches a point in line with the saw, K, the movement of the feed table, C, is stopped and the carriage, J, moved as before, so that the saw, K, will cut or trim off the other end of the piece of lumber. The feed table is then again moved, and the saw edges the opposite side of the piece of lumber. During this latter movement of the feed table the saw, D, cuts in an upward direction, and the spout, H, receives the dust and conveys it to one side of the feed table so that it cannot drop thereon, but will fall on the

floor at one side of it. This spout, therefore, by keeping the feed table free from dust, permits the lumber to rest steady on the feed table, so that it can be cut or edged, while fed to the saw, in either direction. This result could not otherwise be obtained. In slitting lumber the operation, of course, is substantially similar.

The inventor is Benjamin Barker, of Ellsworth, Maine, and he will be happy to furnish any further information. The patent is dated Feb. 8, 1859.

BARKER'S SAWING MACHINE

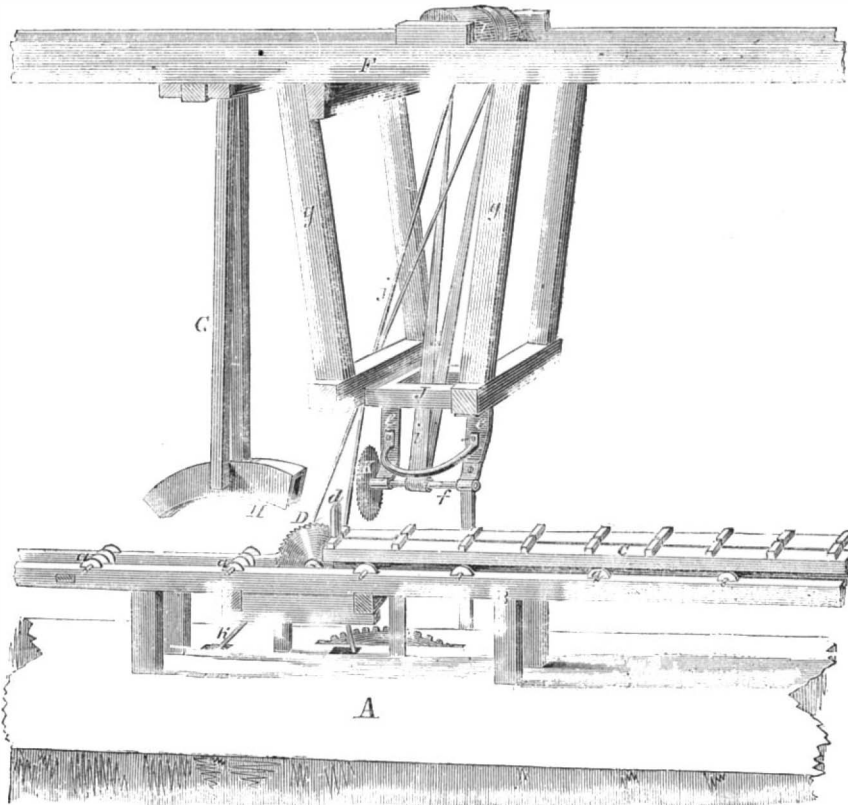

IMPROVED TOOL-HOLDER.

By the use of this invention the cutting edge or point of the tool can be turned to any angle horizontally, and at the same time the point can be elevated or depressed to suit the size of the material to be operated upon, thus giving to the gib lathe the same facility of directing the cutting tool which is now only attained by the weighted lathe.

In our illustrations Fig. 1 is a perspective view and

the pitch of the screw, and looking to the consumption of fuel, which was tried on Saturday; the vessel proceeded to Annapolis, and lay for a short time off the Naval School. The results were in every respect eminently satisfactory. A uniform speed of fifteen miles an hour, carefully timed by the buoys, was attained with 36 revolutions per minute, the boilers working to about one-third of their capacity; and it being, even to the inexpert in these matters, apparent that they were playing with their work. As the experiment was mainly directed to the question of fuel, under certain circumstances, no effort was made looking to speed alone, but quite enough was done to remove all doubt as to the ultimate and triumphant success of the principles involved in the propeller, and the power required to attain the maximum speed in this new form of naval architecture. The results in a sea way are yet, of course, to be tested."

[From all that has been published by our Baltimore cotemporaries about the steamer since its first trial trip, we have not been able to learn the real causes of its want of success, nor does the above give us a tangible idea of the changes which have lately been made to remedy previous defects. We hope Messrs. Winans will yet give a full public account of their entire experience with the cigar-

steamer. Their enterprise commands our admiration, and we wish them success. If they have made miscalculations, that is no disgrace to them; the ablest inventors that ever lived have done the same. Their experience given to the public would be a beacon to inventors and engineers generally.—Eds.

The greater a man is, the less he necessarily thinks of himself for his knowledge enlarges with his attainments.

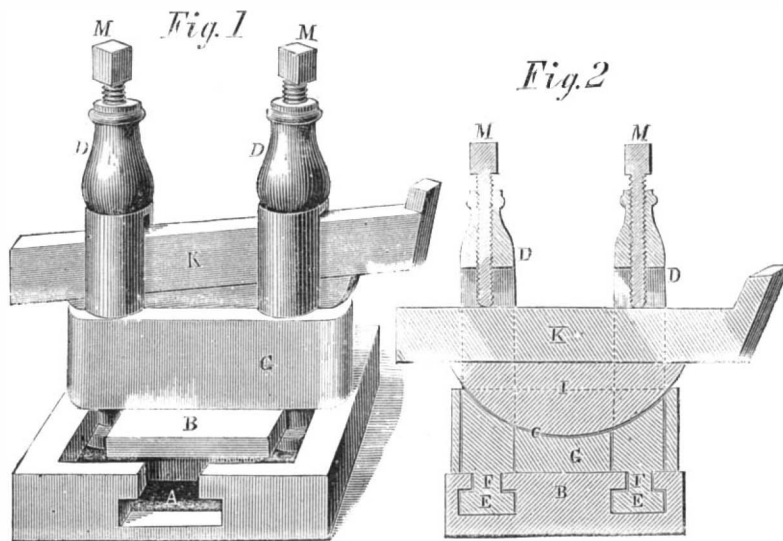

PECK'S TOOL-HOLDER.

Fig. 2 is a vertical section. The bed-plate, B, is made with a T-slot, A, the sides being equal distances apart. The tool-post, D, are of the ordinary form, with a button head, E, and thinned shaft, F, to fit in the slot, A. The tool-rest, G, is made with a semi-circular slot, C, in it, and the base of the slot in the tool-posts, D, is cut to correspond. In this slot the segment, I, rests, carrying on its level top the tool, K, both segment and tool, passing through vertical slots in the tool-posts. The tool has the usual back and forth motion, or in other words, it can



# Scientific American.

MUNN & COMPANY Editors and Proprietors.

PUBLISHED WEEKLY

At No. 37 Park-row (Park Building), New York.

O. D. MUNN, S. H. WALES, A. E. BEACIL

TERMS—Two Dollars per annum.—One Dollar in advance, and the remainder in six months.

Single copies of the paper are on sale at the office of publication, and at all the periodical stores in the United States and Canada. Sampson Low, Son & Co., the American Booksellers, No. 47 Ludgate Hill, London, England, are the British Agents to receive subscriptions for the SCIENTIFIC AMERICAN.

See Prospectus on last page. No Traveling Agents employed.

VOL. I., NO. 7.....[NEW SERIES.].....Fifteenth Year.

NEW YORK, SATURDAY, AUGUST 13, 1859.

## SCIENTIFIC EXPERIMENTS.

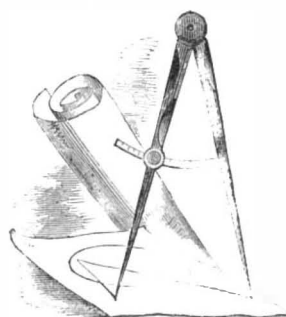

AMERICANS, as individuals, have done and are doing much to advance and improve the industrial arts, and they have acquired a reputation in this respect which commands universal admiration; but this is not the case with us as a nation. Indeed, so far is this from being so in a

national sense, America has rather great reason to feel ashamed of herself in comparison with France, England, and some other countries. We have no institutions for affording assistance and solid encouragement in prosecuting experiments in practical science. "Ah," says one, "you have forgotten the Smithsonian Institute, at Washington." No, sir. That was the gift of a foreigner; and, besides, although it diffuses much knowledge regarding abstract science, it furnishes no assistance for advancing the practical arts. Another says, "We have the American Association for the Advancement of Science." Ah! true; but we did not forget it, either; and as it has just held its Annual Convention at Springfield, Mass., the allusion to it is seasonable. Since the organization of this institution, it has held a convention once, and sometimes twice, per annum, and numerous have been the papers which its members have read to one another; but no ray of light has ever flickered from their scientific lamps to illumine the path of a single explorer in the useful arts. Whatever improvements—and they are many—which our people have made of recent years in manufactures, mining, engineering and invention, and in testing alleged new discoveries by experiments, no assistance or instruction has been derived from that source.

Our government has made appropriations in a few instances, such as for testing the applicability of electro-magnetism as a motive power, &c., &c.; but these really deserve no consideration in a general sense. The only institutions which deserve any credit for encouraging useful improvements among us are our Mechanical and Agricultural Societies, which offer prizes at their annual exhibitions. They have done much, and are still doing much good, and will no doubt do much more. They do all that can be expected from them, according to the nature of their organization; but, nationally, we want some institutions of a different and higher class. When we turn our eyes to England, we find that in London there are several associations of the useful and practical character which we want, and which afford us a good example. The Society of Arts, and the Institutions of Civil and Mechanical Engineers, not only meet frequently to read and discuss papers on useful subjects, and to award prizes for essays, discoveries and inventions, but also have committees appointed for making experiments, the members of which are provided with the necessary funds to prosecute their undertakings. We can scarcely take up a single foreign periodical in which we do not find an account of mechanical experiments conducted by some committee, either appointed by the government or one of the institutions we have named. In the annual report of the Society of Arts for the past year, we find that several committees have carried out a regular system of experiments. Thus, a committee

appointed to investigate a new gum, called "pauchon-tee," obtained from a tree similar to gutta-percha, in the East Indies, report that they have analyzed it and experimented with it to discover its properties, and decide (against previously expressed opinions) that it cannot be used for the same purposes as gutta-percha. Other committees reported similar operations, all tending to the establishment of new and important results. The Institution of Mechanical Engineers furnished Mr. Fairbairn with funds, last year, to make experiments in testing the strength of boilers, and the result was the remarkable discovery that boiler-flues were, in general, made far too weak, and that the common opinion, which inferred that they could stand as much pressure on the outside as the inside, was erroneous. The British Association for the Advancement of Science appointed a committee for making experiments on water falling through notches, and it was also furnished with means to defray the necessary expenses. The reports of these committees, and the discussions which result therefrom, are of unusual interest, and tend greatly to advance practical science; and for this reason we really wish we had some such thoroughly useful national institutions among ourselves. When we reflect upon the practical genius of our people, and what they have done by individual effort, we are confident that science and art in our country would progress still more rapidly than it ever has done, were more facilities and assistance furnished to make experiments for the public benefit.

We would make an exception to the Franklin Institute, of Philadelphia, as it has undertaken a number of valuable experiments, such as on boilers and water-wheels, and the reports on these are held to be standard authority by reliable writers on scientific subjects. Yet, even this institution is not half so efficient as it ought to be, and as it would be, were more funds furnished by the friendly people of that city for conducting systematic and continuous efforts of this character by the able members of the association.

As public monitors and watchmen on the tower of science and industrial art, we have presented the foregoing conclusions to stimulate our people not only to higher aims and objects, but higher and more effectual practice in a national sense. The large prize which has been offered this year by the Illinois Agricultural Society, and several respectable premiums which are annually offered by other associations, afford evidences of the right spirit among our people for the encouragement of inventors and the development of new improvements. Were this spirit properly directed, and continually exercised by systematic experiments, we would have such an institution as one of those to which we have referred by way of example. We hope these remarks will lead to such a result.

### WATER-GLASS OR SOLUBLE SILICATES.

A pamphlet on this subject has been translated into English from the German of Dr. I. N. Von Fuchs, by direction of Prince Albert, for private circulation, and it has become quite public by large extracts being copied into the London periodicals. Its leading features deserve a wide-spread circulation, and we will therefore present them through our columns. Four kinds of silicates are described, namely, *potash*, *soda*, *double* and *clear*. The first is composed of 15 parts pulverized quartz (a pure sand), 10 of purified potash, and 1 of powdered charcoal. These substances are first well mixed and exposed to a strong heat in a glass melting-pot for five hours, until the whole fuses uniformly; the heat required being about the same as that which melts glass. It is now lifted out, and when cool, it is broken in pieces and dissolved in about five times its bulk of boiling water. It is kept boiling for about three hours before it is all dissolved, and water is added as evaporation proceeds, so as to keep up the original quantity. It now becomes slimy, and in that state, or more diluted, is fit for use in many operations. It should be placed in well-stoppered bottles for use.

The second silicate is composed of 45 lbs. of pure quartz, 23 of anhydrous carbonate of soda, and 3 of powdered charcoal. This is fused in the same manner as the other. By substituting anhydrous sulphate of soda for the carbonate of soda, and using about eight times more charcoal, a cheaper silicate is formed, and both are soluble by boiling in water. Rectified alcohol precipitates the potash silicate from its water, and converts it into a solid silicate, which is dissolvable in

water. The potash and the soda silicates mix freely with one another.

The double-soluble silicate is composed of 100 parts quartz, 28 purified potash, 22 neutral anhydrous carbonate of soda, and 6 of powdered charcoal. This mixture fuses much easier than the other two, but three measures of the potash silicate and two of the soda silicate described, when mixed together, will answer for all practical applications.

The fourth silicate, which is applied to fixing the colors of pictures, is made by fusing 3 parts pure anhydrous carbonate of soda with 2 parts of powdered quartz, which is boiled as described for the other silicates. This is kept in a concentrated solution, and one measure added to four parts of concentrated potash silicate completely saturated with quartz. By this means, silica and an excess of alkali are obtained, which, although more soluble, is clear, and not rapidly decomposed. This soluble silicate should only be employed in stereochromy-painting.

The first two soluble silicates, when mixed together, form an excellent cement with sand, and convert it into a stone-like mass. It is also excellent for filling up cracks in walls, as it acts very much like mineral glue.

When marble dust or chalk is made into a paste with water, then dried, and afterwards saturated with the silicate, it forms a compact mass, and acquires a hardness little inferior to solid marble, and it is capable of taking a fine polish, and water will not soften it. A mixture of marble-dust and the silicate of soda forms a cement which adheres either to wood or stone.

The oxyd of zinc and soluble glass combine with great energy, and form a paste capable of being rolled out and made into sheets to cover substances, such as wood, with a coat resembling polished slate. A patent has been taken out by a Mr. Hoard, of Providence, R. I., for writing-slates made of this composition.

One of the most important applications of water-glass is to painting. It enables the colors to adhere, renders them almost indestructible, and is therefore calculated to supersede fresco-painting. Some splendid mural paintings in the museum at Berlin have been treated with the soluble silicate; they are stated to be splendid works of art, and far in advance of fresco-painting for durability. Artificial sulphate of baryta, applied to glass by means of silicate of potash, imparts to it a milk-white color of great beauty; in a few days the silica is found intimately combined with it, and the color resists washing with warm water. By the action of strong heat, this silicious varnish is transformed into a fine white enamel. Blue ultramarine, oxyd of chromium and pulverized colored enamels may be applied. Silicious-painting upon glass is destined to find advantageous employment in the construction of church windows; while silicious-painting upon stone will serve for mural decoration.

The oxyds and metallic salts which enter into the composition of silicious colors or of cements have the property not only of combining with the silica of the silicates, but also of fixing, in an insoluble state, variable quantities of potash. The colors which act most energetically in this respect are the ochres; oxyd of manganese, oxyd of zinc, oxyd of lead, and artificial sulphate of baryta.

From the information contained in the above pamphlet, we conclude that the soluble silicates are applicable to a great number of purposes, and that they will yet come into extensive use.

THE Hon. Commissioner of Patents is now absent from his official duties, and will sojourn for several weeks at his residence in Connecticut. We hope, on his return to Washington, that he will give his earnest attention to some needed reforms in the proper examination and disposal of applications. The Office is sadly behind in some of its departments, and we feel assured that the Commissioner will use his best endeavors to rectify the existing difficulties.

THE editors of the SCIENTIFIC AMERICAN, aided by a corps of experienced examiners, still continue to examine and give written opinions of the novelty of supposed new inventions. All they want to enable them to understand an invention is either a pen or pencil sketch and description or a model and description. Inventors can always freely consult us, either by letter or at our offices, at No. 37 Park-row, this city.

## THE FATHERS OF PHILOSOPHY.—VII

PLATO.

The philosophy of Plato was full of so many maxims and ideas similar, in a great measure, to those enunciated in the Bible by the Divine Founder of our faith, that many of the Christian fathers not only thought very highly of them, but further recommended them to their pupils and quoted them in their works, and many said that the study of Plato's doctrine the better enabled them to understand their own enlightened religion. He taught in physical science that the heavens were not solid, but liquid (as air) and ethereal. He was a learned mathematician and astronomer, and believed in the influence of music on the human mind. He was born in the city of Athens, in the year 430 B. C. In his earliest years he gave evidences of distinguished genius, and whilst he was very young had tutors in mental and physical exercises, so that his mind and body were equally exercised and ensured him perfect health, and enabled him to live and learn, as well as teach, to a good old age, as he did not die until his 81st year, in 348 B. C. It would be well if such a system was adopted in this country, and then men of genius would no longer have to bear up against a broken-down constitution, and live on the by-laws, as Rufus Choate said *he* did. In Plato's early days, he wrote an epic poem; but, on comparing it with Homer, so disgusted was he at his own inferiority that he burnt the manuscript; and at 20 he wrote a dramatic piece, which was being rehearsed by the actors for production at the time he made the acquaintance of Socrates, and he became so ardent a devotee of philosophy that he withdrew it the night before it was to have been performed.

For eight years he was a disciple of Socrates, and he sometimes drew upon himself the displeasure of his fellows, and even his master, by trying to introduce new ideas; yet so fond were they of each other, that when the old man was summoned before the Senate, Plato undertook his defense, but when he commenced his speech the judges would not allow him to proceed. Still he remained devoted to his master, and, when he was condemned, offered him money enough to redeem his life, which Socrates refused. Upon the death of the man of wisdom, Plato and his friends moved to Megara, where Euclid hospitably entertained them until it was safe for them to return to Athens. While with the great geometrician, he studied the art of reasoning, and acquired a greater love and talent for disputation. It was at this period of his life that he started on his travels; and under the disguise of a merchant and oil-seller he went into Egypt, and traveled the whole kingdom of Artaxerxes Memnon, learning from the priests astronomy and mathematics.

On his return, so famous had he become, that nations petitioned him to assist them in remodeling their governments, but he rejected all applications, because no one was prepared to adopt his idea of a republic with an equal distribution of money. At last he consented to go to Sicily, to endeavor to subdue the temper of its tyrant, Dionysius, and to study the phenomena of Mount Etna; and, while there, rescued the King's brother-in-law from a course of depravity and dissipation. The tyrant, however, when Plato began to point out his cruelties and vices, made a plot against his life; but the philosopher escaped (as he thought) well, when he was surprised to find himself sold for a slave on his mother's native island, Ægina, the inhabitants of which were at war with the Athenians.

Here he met a brother philosopher, who purchased his freedom and sent him home to his friends. When the Athenian friends of Plato wished to repay the Æginian philosopher, he refused the money, alleging that he saw no reason why Plato's relations should engross to themselves the honor of serving him. Again he went to Sicily, and was again dismissed; and a third time he went on his mission of goodness, and, after much maltreatment on the part of Dionysius, his friends at Tarentum interfered, and the tyrant gave him a magnificent entertainment, loaded him with presents, and sent him away. This philosopher was never married, and was buried in the grove and garden which had been the scene of his philosophical labors and reflections. The day of his death was long kept as a festival, statues and altars erected to his memory, and his portrait is still engraved on cameras and gems.

## RAILWAY BRIDGES AND ACCIDENTS.

Our railway bridges are a disgrace to American engineering management. We are confident that we come within the mark, in asserting that two-thirds of all the great railroad accidents which have occurred in this country have been caused by defective bridges. The terrible disaster at the Norwalk Bridge, on the New Haven Railroad, which took place a few years ago, is still fresh in our memory; and still more fresh is the awful calamity which took place on the 11th of May last year, on the New York Central Railroad, at Whitestone, by the breaking down of a defective bridge. Later still, we have had the sad accident on the Michigan and North Indiana Railroad, by the destruction of the culvert near South Bend, in the early part of last month; and lastly (perhaps the most heartrending and disgraceful of all), is the accident at Schaghticoke, on the Northern Railroad, near Albany, which took place on the 3d inst. by the fall of a rotten bridge under a passing train. It is not necessary for us to go back and comment upon the great destruction of life and property caused by all the accidents to which we have alluded, but we cannot pass over the last one named, as it is so recent, without some amplification of details.

By this distressing event nine persons were killed, and 17 wounded—some dangerously. The bridge that broke down was of wood, with a span of 60 feet crossing the Tomhannock creek. It had been reported dangerous to the company, and a new bridge to replace it was in the course of construction. The locomotive engineers were ordered to be careful in crossing it, and the evidence is, that much caution was used by the engineer of the train—C. H. Jones—on the occasion. The hour was 6 $\frac{3}{4}$  P. M., the train consisted of the locomotive, "Ten Eyck," a tender, two baggage and two passenger cars—the latter well filled. The engine passed over in safety, but just as it had reached the south side, while the tender was upon the bridge, and the rear wheels of the locomotive had not yet left it, the engineer felt that he was sinking. His hand was upon the valve, and in falling backward, his whole weight rested upon it. The valve was thrown wide open, its whole volume of steam rushed into the cylinders, and with a mighty strain, the huge machine bounded forward, off the falling bridge, breaking its connections, clearing the track, running along the side of the road for about fifteen feet, and stopping just as it had begun to turn over upon its side.

When the engine cleared the bridge, it had probably sunk about two feet below its usual level. The tender did not follow the locomotive, but dashed against the abutment, and then sank, with a great crash, into the stream. The baggage cars came thundering upon it, and were broken to pieces, lying in a heap in the water. The first passenger car plunged headlong down the chasm, striking upon its forward end at a short distance from the abutment, upon which the rear end rested. The second passenger car passed directly over the first, and remained resting upon it. The first passenger car was sustained by the wrecks both of the bridge and baggage cars, while the second passenger car rested entirely upon it. The passengers in both cars were hurled violently from their seats, and cast together in dead and mangled heaps at those ends which went into the water. The shock of the concussion was terrific—as a survivor describes it, "it seemed as if we had fallen a mile and struck upon solid rock." After the descent shrieks and groans filled the air, and the vain attempts of those who were under the water to escape, coupled with the cries of the living for help, made up a scene of the most fearful terror. As soon as possible, those who were unhurt or only slightly injured, got out from the wreck, and by every means in their power, devoted themselves to the rescue of their less fortunate companions.

The citizens of Schaghticoke were early on the spot and afforded every possible assistance. It seems they had frequently talked about the condition of this bridge, and were continually expecting such a disaster. Mr. W. Dexter, publisher of the *Shoe and Leather Reporter*, of this city, was on the train, and fortunately escaped with a slight bruise. He states that the injured passengers were crushed into every shape, and the dying agonies which he heard beggar all powers of description.

In the morning he visited the place and made a thorough inspection of the ruins. The height of the abutments from the bed of the stream was 42 feet. All the fragments of the bridge lay at the bottom of the chasm—not

a piece leaning against the stone-work, and every timber and brace was rotten. He was informed that the farmers in the neighborhood had repeatedly warned the railroad people of the bad condition of the bridge, and some of those employed on the road told the managers it would break down, the bridge having sagged out of place from actual weakness.

Such are some of the statements which have been made public regarding the cause and the scenes connected with this heart-rending accident. It is self-apparent that the most reckless want of forethought in keeping this section of the railroad in proper repair was displayed. To whom this duty was intrusted we do not know; but as this is not a singular case, we must conclude that, as it regards the care of our railway bridges generally, the charge of *incapacity* must be shared by most of our railroad companies. Talk as we may of ability and skill on the part of railroad superintendents and directors, it requires but little penetration to perceive that many of them lack the first qualities for filling such responsible situations, namely, industrial care in keeping bridges in proper order.

A decided reform appears to be demanded in the construction of such bridges. Instead of the sustaining structure being made of fragile perishable materials, like timber, it should be composed of enduring and imperishable materials, like stone or iron—the latter well protected from rusting.

This accident will entail a heavy loss upon the company, from the damages which must be paid to the injured passengers and the surviving relations of the deceased. If a new bridge had been put up last year, in place of the late broken-down rotten one, it would have saved, perhaps, \$50,000 to the company, and many valuable lives to the community. Our railroads have been managed with a cent-wise and dollar-foolish economy; it is time that a vast radical reform was instituted among them.

The coroner's jury at Schaghticoke, in this case, have returned a verdict that the timbers of the bridge were rotten and unsafe, and known to be so; and that the superintendent and directors should be held responsible. This verdict should cause the District Attorney to bring the matter before the Grand Jury, with a view to the criminal indictment of the parties.

**GEOLOGY AT FAULT.**—It has hitherto been taught as a geological fact, that the granite rocks were formed before any of the organisms existed on our globe, and that wherever granite was found *in situ*, it might be taken for granted that it was a primitive formation, below which none of the limestone or fossiliferous rocks could be found. This theory seems to be wrong, according to a paper read before the Association of Science by Prof. Hitchcock. In it he describes what is called "a geological phenomenon," near Lake Memphremagog, which consists of a mass of granite overlying fossiliferous rock and injecting dikes downward into the limestone. Sir William Logan, of Canada, confirmed the statements of Prof. H., and gave reasons for supposing the granite of Maine to be younger than the limestone, but older than the coal formations.

The western Canadians have at length imitated the Americans, and sent a vessel from one of their ports to Europe direct. The *Union*, laden with staves, sailed lately from Hamilton, a city at the head of Lake Ontario. She was chartered by Messrs. Lang & Delano, of Boston, and consigned to their agent in Liverpool. She had 100 mille of staves on board: 1,200 to the mille, and the freight given is \$3,500. The direct lake trade is assuming important proportions. If the canals on the St. Lawrence were enlarged, some of the inland cities would soon rival those on the seaboard.

The Seventh Exhibition of the Kentucky Mechanics' Institute will be held in Louisville, Ky., commencing on September the 6th. The hall will be ready for the reception of goods on the 20th of this month. The rules and regulations are very liberal, giving every facility for apprentices and minors to show their skill and compete for suitable premiums.

We have to thank Lieut. M. F. Maury for a copy of the astronomical observations made during the years 1849 and 1850, at the United States Naval Observatory, Washington.

FOREIGN SUMMARY—METALS AND MARKETS.

One of Bishop's American floating derricks having been put up on the Thames, in London, it has furnished a theme of admiration to several of our cotemporaries of that city.

A new fossil has been discovered in lignite, near Banbury. It is found in fragments of the size of a man's fist, of a light yellow or greenish hue, translucent, somewhat ductile and elastic, and with a density of 0.968.

A merchant of Russia announces the sale, in his warehouses at Odessa, Nicolaieff and Sevastopol, of 7,351 tons of iron and cast-iron, coming from projectiles picked up in the Crimea after the war, which gives some idea of the prodigious consumption of shot and shells in the siege of Sevastopol.

The South Australian Gazette states that the total quantity of gold brought from the mines by escort up to the 15th of April, 1859, was 623,300 ounces, against 629,918 ounces during the same period in 1858.

The Great Eastern (formerly Leviathan) steamship is rapidly approaching completion. A whole army of workmen are now busily engaged in getting forward her internal fittings. Half of her six masts are up and rigged. The two paddle-boxes weigh about 600 tons.

An alarming illustration of the dangers attending the absence of communication between railway passengers in the cars and the engineer recently took place on a train running between Manchester and Chester. The passengers' luggage in the first-class car took fire and spread rapidly, while the engine sped on with tremendous velocity.

tuns, exclusive of engine room, which amounts to 441,878 tuns; total, 1,122,331 tuns.

There has been a great decline in the pig-iron trade of Great Britain during the past year, and a rapid increase of that in Prussia and Belgium.

By the report of the Board of Trade, just published, for the month of May, there was a great increase in the exports of hardware to the United States and other countries. The total value of exports was £354,489 against £280,974 for the same month last year.

Last week the cotton market at Manchester and Liverpool appeared to be on the rise; this week it is rather fluctuating, although there has been no great downward tendency. 50,340 bales are reported to have been sold at Liverpool, at a fall of about 1/8 per lb.

Table of American securities and their prices, listing various bonds and shares with their respective values and percentages.

Our usual table of the price of metals is omitted this week. We will state, however, that rails have advanced 5s. per tun and Scotch pig-iron 6s. The market was firm. Considerable was done in spelter at £21 per tun.

If those who are not acquainted with British currency will value £1 at \$4.84 and 1s. at 24 1-5 cents, they will obtain a comparative idea of the prices in sterling and United States currency.

New York Markets.

COAL.—Foreign canal, \$9; Anthracite, from \$4.50, \$4.75, to \$5.50. CORDAGE.—Manilla, 3/4c. a 3/4c. per lb. COTTON.—The sales were not so favorable this week, and the prices have somewhat fluctuated.

\$1 35; lard oil, No. 1 winter, 85c, a 90c; extra refined rosin, 80c. a 40c; machinery, 59c a 100c; camphene, 45c. a 47c.; coal, refined, \$1.13 a \$1.50.

RESIN.—Common, \$1.77 1/2 per 310 lbs. bbl.; No. 2, &c., \$1.50 a \$2.12 1/2; No. 1, per 280 lbs. bbl., \$2.25 a \$3; white, \$3.25 a \$4.50; pale, \$4.50 a \$6.25.

STEEL.—English cast, 14c. a 16c. per lb.; German, 7c. a 10c.; American spring, 5c. a 5 1/2c.; American blister, 4 1/2c. a 5 1/2c.

TALLOW.—American prime, 10 1/2c. to 11c., per lb. TIN.—Banca, 34c. a 34 1/2c.; Straits, 32c. a 32 1/2c.; plates, \$7.50 a \$9.87 1/2 a \$10.08 per box.

TURPENTINE.—Crude, \$3.62 1/2 per 280 lbs.; spirits, turpentine, 44 1/2c. a 45 1/2c. per gallon.

ZINC.—Sheets, 7 1/2 a 7 3/4 per lb. The foregoing rates indicate the state of the New York markets up to Aug. 4.

HORSESHOE NAILS.—Mr. J. Coggeshall, agent of the American Horseshoe Nail Co., Providence, R. I., informs us that the price of their nails per pound, delivered at Boston, New York, Philadelphia and Baltimore, is 14 1/2 cents.

ALBANY LUMBER MARKET, AUG. 3.

We learn from the Albany "Journal" that there was some improvement in the lumber trade during the week preceding the 3d inst. The demand is not confined to any single locality, but is scattered throughout the northern States.

There is very little alteration to notice in our prices current. Two-inch spruce plank have slightly improved in value, and white wood chair plank has depreciated.

Table listing various lumber products such as Pine, Spruce, Hemlock, and their prices per M or per 1000.

NEW YORK ASSAY OFFICE.

Statement of business at the United States Assay Office at New York for the month ending July 30, 1859:

Table showing deposits and purchases of Gold and Silver, and total deposits payable in bars and coins.

Although so much coal, lard and resin oils are now manufactured, the whaling business is better at present than ever it was before, and New Bedford (Mass.), the great whaling port, is at present exceedingly lively with shipping.

California wool has become quite an article of commerce in our marts. 30,000 lbs. of it were sold last week for 24c. a 32c. per lb., according to quality.

Many persons have inquired of us "What is spelter?" It is the commercial name for unmanufactured zinc.

Horns are subjects of a considerable commerce among us. 15,000 of them, once the property of oxen that grazed on the Rio Grande, in South America, were sold in this city last week.

## NEW INVENTIONS.

**SEWING-MACHINES.**—As the sewing-machine becomes more generally used, and finds its way into more homes and houses, so sure is it of being continually improved, either in shape, form or mechanical arrangement, or else some new invention will be added to it which will change the character of the machine, giving it greater capabilities and simplifying its construction. Such we find to be the case, as in this week's list of claims we discover no less than three useful improvements in the machine alluded to.

The first is the invention of G. L. Jenks, of Providence, R. I., and it relates to that description of machine in which the hooked or barbed needle is employed to produce the chain-stitch. The invention consists in the arrangement of the needle to work in such a manner obliquely to the plane of motion of the cloth or other material to be sewed, that on that side of the machine on which the enchaining of the loops is performed the needle shall form the greatest angle with the said plane on the side towards which the material moves, by which means the loops, as they are severally drawn up through the material and through their predecessors, allow the latter to be drawn up shorter, and hence enable a tighter stitch to be made with a less degree of strain on the thread than is necessary in the chain-stitch machines in common use, thus permitting a commoner quality of thread to be used, and bringing the chain side of the stitch closer into the material. The invention also consists in a certain arrangement of a thread-guide and a pair of nippers, in combination with each other, for conducting the thread into the hook of the needle and assisting in drawing the stitches tight.

The second is the invention of H. W. Hayden, of Waterbury, Conn., and relates to the formation of what is known as the lock-stitch, by means of a revolving and a vibrating arm and hook for extending the loops of the needle-thread, and a peculiarly arranged bobbin for supplying the locking-thread, operating in combination with each other and with the needle. It also relates to the method of means for producing the operation of the revolving and vibrating arm and hook; also, to an improved device for taking up the slack of the loop between the bobbin and the revolving and vibrating hook; and, further, to a new contrivance for feeding the material to be sewed.

The third is the invention of David Kelsey, of Harper's Ferry, Va., and relates to what is known in the sewing-machine as a top-feed; and it consists in so applying a separate feeding-dog, in combination with the pressure-pad, that when the dog is pressed upon the cloth or other material under operation in the machine, it is made to lift the pad and leave the material free of the pressure of the pad, and the latter is prevented interfering with the dog during the feeding operation. The invention also consists in certain mechanism for combining the pressure-pad and feeding-dog with the needle-bar for effecting the above-mentioned operation.

**KNITTING-MACHINE.**—That well-known inventor of knitting-machinery, J. Bradley Aiken, of Manchester, N. H., has invented and patented another improvement in such machines, which principally consists in a stop-motion, regulated by the work instead of the yarn, as formerly, and the whole end of the invention is to simplify these machines and render them less liable to accident, and to enable them to be more extensively used even than at present. He has obtained a patent in England for the invention.

**REVOLVER.**—S. C. Lewis and F. P. Pflieggar, of Whitneyville, Conn., have invented and patented an improvement in revolvers, which consists in a certain improved construction of and mode of applying the central pin upon which the many-chambered cylinder rotates, whereby greater facility is afforded for the removal of the cylinder when desired. It also consists in an improved mode of applying the dog and ratchet, through which the cylinder derives its rotary motion from the hammer. It also consists in an improved mode of applying and operating the stops by which the cylinder is locked while the hammer is cocked and during the discharges of its chambers. There is an improved construction of the recoil-shield, and of the catch for securing the end of the lever of the ball-rammer against the barrel when the rammer is not in use.

**MAKING HOLLOW-WARE.**—L. P. Rood, of Deposit,

N. Y., has invented and patented an improved lathe for making wooden hollow-ware. It consists in the employment of a rotating mandrel, in connection with a tool-rest and cutter, these parts being attached to a suitable bed, and the whole being so arranged that the bodies of wooden vessels may be very expeditiously cut from the solid.



ISSUED FROM THE UNITED STATES PATENT OFFICE  
FOR THE WEEK ENDING AUGUST 2, 1859.

[Reported Officially for the SCIENTIFIC AMERICAN.]

\* \* Pamphlets giving full particulars of the mode of applying for patents, size of model required, and much other information useful to inventors, may be had gratis by addressing MUNN & CO., Publishers of the SCIENTIFIC AMERICAN, New York.

24,914.—Paul Francis Aerts, of London, England, for an Improvement in Axle Boxes for Lubricating Rolling Stock, &c. Patented in England March 19, 1858:

I claim the wheel, a, fixed on the end of the journal in railway rolling stock raising water by centrifugal force, and the divergent, c, for conducting the water over the greased surface of the journal or moving parts of machinery working in fixed bearings, when constructed and arranged substantially as set forth.

24,915.—Frederic Adams, of Somerville, Mass., for an Improvement in Casting Copper Cylinders:

I claim, as a new article of manufacture, a tube or cylinder cast out of copper, and free from blow-holes and other similar defects when stated.

24,916.—Jonas Bradley Aiken, of Manchester, N. H., for an Improvement in Knitting Machines:

I claim, first, The lever, Q, grooved eccentrically to its fulcrum, applied in combination with the sliding loop regulator to adjust the same for different lengths of loop, substantially as specified.

Second, The stop-motion, consisting of the lever, Y, and its self-adjusting dog, I, the ring X, with its pins 13 13, or their equivalents, and the sliding bolt, W, or its equivalent, carrying the slipper, W', the whole combined, applied and operating substantially as described.

24,917.—Wm. Baker, of East Templeton, Mass., for an Improved Tool for Riving Hoops:

I claim a hoop-riving tool, formed of a stock, A, provided with suitable guiding surfaces, a, a', and differently arranged or set stock faces, b b', and knives, D D', for operation, essentially as set forth.

24,918.—T. C. Ball, of Keene, N. H., for an Improvement in the Mode of Hanging Brake Rubbers:

I claim the combination of the brake-head and spring, as above described, also the arrangement of the brake-beam, F, Fig. 1, so as to allow its independent action upon brake-head and spring A and D, as described.

24,919.—Thos. L. Ball, of New York City, for an Improved Show-case:

I claim the construction of a case or box divided into compartments, each box having a sliding cover, arranged as set forth, in combination with the spring covers, G, and compartments, F, constituting a new article of manufacture.

[This invention relates to all varieties of boxes or cases for containing fancy articles, particularly for needles, gloves, &c., where there are various sizes and descriptions numbered accordingly, and assorted in separate compartments in one box or case for exhibition or sale. The object of the invention is to construct a box of any desired size or shape containing any number of compartments for holding the articles according to their assortment, each box having a separate and independent cover which can only be removed by the salesman, and he being only able to remove one at a time, thus saving much trouble and expense by exposing to the air and handling more goods than are required for immediate examination.]

24,920.—Wm. T. Barnes, of Buffalo, N. Y., for an Improvement in Apparatus for Condensing Coal Oils:

I claim, first, The employment of tube, K, the lower extremity of which is provided with tubular arms, L L, the same being made to revolve, and being used in connection with a tank partially filled with water, and a conducting pipe, F, substantially in the manner and for the purpose set forth.

Second, The arrangement and employment of the tanks, A B C, constructed and used substantially in the manner specified and for the purpose set forth.

24,921.—Wm. T. Barnes, of Buffalo, N. Y., for an Improved Apparatus for Generating Coal Oils:

I claim, first, The arrangement of the levers, L K, and J, and rod, I, whether operated by a cam or otherwise, for the purpose of forming an automatic dust clearer to coal oil retorts, as is substantially set forth.

Second, The employment of the spiral or screw flanges on the head of the retort for pushing the material away from the hole in the journal, as fully described.

24,922.—Daniel Bassett, of White Water, Wis., for an Improvement in Mills for Crushing Sugar Cane:

I claim, first, The arrangement and combination of the tongue and groove rollers, A B, wiper, F, and "stripper," as and for the purpose shown and described.

Second, The "stripper," when composed of spring caps and a movable cam, G, and when arranged and combined with rollers, A B, substantially as and for the purpose shown and described.

24,923.—Albert Betterley, of Boston, Mass., for an Improvement in Elevators in Warehouses, Factories, Mines, &c.

I claim, first, The combination of an automatic safety shipper and brake apparatus with an elevator, substantially as described, arranged to operate only to prevent an elevation of the car beyond a fixed limit.

Second, The combination of the weight, G, flexible rope or chain, e, with the shipping and brake-controlling mechanism, substantially in the manner and for the purpose set forth.

24,924.—C. C. Bisbee, of Rochester, N. Y., for an Improved Spring Bed Bottom:

I claim the arrangement described of the slats, D, belts, Y, rollers,

J, cords, R and R', and springs, P P', in the construction of spring-bed bottoms.

I also claim the unequal cams, B and B', for the more perfect automatic adjustment of spring beds.

24,925.—Abraham Bower, of Pekin, Ill., for an Improvement in Machine for Raising Water, &c.:

I claim the combination of the lazy tongs, G, the slide trough, J, and valvular bucket, H, arranged for joint operation, substantially as and for the purpose set forth.

[This invention consists in attaching a bucket to a system of levers generally known as the lazy tongs, and connecting them to a windlass so that a very simple and efficient elevating device is obtained. The invention also consists in the employment or use of a valvular bucket in connection with a slide trough for the purpose of facilitating the discharge of the material raised. The invention is more especially designed for elevating water from wells, but it may be advantageously employed for raising grain in mills, or from mines and other purposes.]

24,926.—Samuel Boyd, of Brooklyn, N. Y., for an Improvement in Manufacturing Hoes:

I claim the employment of an anvil, having an inclined face, a, groove or recess, c, and socket, D, in combination with a mandrel, F, as shown and described, whereby the bevel or set of the blade and eye, and the form, thickness and bevel of the interior of the socket or eye will be uniformly and simultaneously produced as set forth.

[By this invention the manufacture of that class of hoes which are provided with eyes to attach them to the handle is facilitated and perfected, and it relates chiefly to heavy hoes, such as those used in the cultivation of southern crops and called "planter's hoes."]

24,927.—J. R. Brown, of Boston, Mass., for Improved Pipe Tongues:

I claim the arrangement and application of the serrated surface or rack, h, the spring, F, and toothed stopper, D, with respect to the two jaw levers, A B, the clamp nut, E, and the screw-pin, C, applied to the toothed jaw lever, A, substantially as described.

24,928.—Moses Bucklin, of Grafton, N. H., for an Improved Draining Machine:

I claim, first, The arrangement of the platform, E, with the cutter blade, F, and plowshare, G, for the purpose of cutting underground drains, substantially in the manner specified.

Second, Arranging the blade, F, with a sloping cutting edge, d, so that the same may readily pass over obstructions which may come in its way, substantially as described.

Third, The arrangement and combination of the platform, E, the cutter-blade F, and the plow-share, G, with the adjustable bars, D, and wheels, B, to operate substantially in the manner and for the purpose described.

[The object of this invention is to make drains sufficiently deep under ground that they will be protected as much as possible from external influences, and the invention consists in arranging a wedge-shaped share at the lower end of a cutter, the cutting edge of which slopes up from the share towards the board or platform to which it is fastened by means of screws, so that they can be drawn through the ground, and an underground drain made. All the parts are capable of adjustment.]

24,929.—John F. Galley, of New York City, for an Improved Ironing Table:

I claim, first, The treadle, C, the fulcrum arm, D, the upright shaft, E, the side jaws, 6 and 7, the spiral spring, 8, and the thumb-screw, 9, when arranged and combined substantially as described and for the purpose set forth.

Second, The hollow screw collar, F, on the shaft, E, constructed and applied substantially as described and for the purposes set forth.

24,930.—T. B. Garside, of Danville, Iowa, for an Improved Portable Field-Fence:

I claim the combination of the long main posts, d, short auxiliary posts, e, and triangular pivoted brace, a b, or its equivalent, when arranged in the relation to one another, and to operate substantially as and for the purpose set forth.

[This invention avoids the necessity of having the main posts of the fence enter the ground, so as to soon decay. It also saves the labor and expense of making a new structure when the stays or supports give out. The improvement consists in arranging short auxiliary posts at right angles to the inside of the panel, and keep the main posts elevated above the ground by means of an intermediate triangular brace which is so arranged and pivoted to the auxiliary posts that the force of the wind in any direction tends to keep it more firmly in its place. While these advantages are secured, the fence is capable of being turned over so as to throw its braces outside of the enclosure and thus afford facilities for plowing close up to the panels. We regard this as being a capital fence, and shall shortly publish an engraving of it.]

24,931.—Frederick Augustus Genth, of Philadelphia, Pa., for an Improvement in the Manufacture of Phosphoric Acid and Phosphates:

I claim the process of manufacturing phosphoric acid or phosphates by treating the phosphates of iron, alumina, or lead, substantially as above described by means of sulphuric acid or its equivalent.

24,932.—James Gilfillan, of Hartford, Conn., for an Improvement in Gas-burners:

I claim the improvement in gas-burners described, consisting of a central exit tube supplied with apertures, surrounded by the gas-chamber, having its discharge regulated by the mercury cap, the upper end of said pipe being furnished with a nozzle, or jet-burner, the whole constructed and operating substantially as set forth.

24,933.—C. F. Greely, of East Kingston, N. H., for an Improved Cloth-Holder for Washing Crockery, &c.

I claim the described washing vise, constructed as and for the purpose set forth.

24,934.—W. S. Hall, of Quincy, Mass., for an Improved Churn:

I claim the combination of the frame of stationary transverse bars with the rotary hollow shaft, and hollow arms thereto attached for the introduction of air and the solid arms attached to the shaft, as substantially described.

24,935.—P. J. Hardy, of Boston, Mass., for an Improved Recumbent Chair:

I claim the peculiar construction and arrangement of mechanism described for actuating the back and leg rest, whereby they cannot only be brought from a vertical into horizontal, or nearly horizontal position, so as to constitute a couch, but be maintained in such or any intermediate positions that may be desirable, such mechanism consisting of the levers, e, c, and d, connected with each other, the back and leg rest, or leg rest frame, f, respectively in manner as set forth. And, in combination with the said construction and arrangement of mechanism for actuating the said back and leg rest, I claim the arrangement of the locking contrivance (constructed and applied as described), whereby the back and leg rest, when placed in any desirable position, may be firmly secured in such positions or be released therefrom as circumstances may require.

24,936.—A. V. Hill, of Hinsdale, N. Y., for an Improvement in Breech-loading Fire-arms:

I claim the combination of the bed piece, breech-pin, and connecting rod, which in connection forms the sliding process, and operating as described.

**24,937.**—Hiram W. Hayden, of Waterbury, Conn., for an Improvement in Sewing-Machines:

I claim, first, The attachment of the looping hook, *I*, to an arm, *I*, or its equivalent, which has a revolving motion, and also a vibrating motion, in a direction transverse to its revolution, and operates substantially as described, in combination with a bobbin, *K*, arranged relatively to it, substantially in the manner set forth.

Second, The stationary cam, *J*, applied in combination with the revolving arm, *I*, which carries the looping hook, and with a spring, *R*, and sleeve, *Q*, or their equivalent, for holding the said arm in contact with the said cam, to produce the vibrating motion of the said hook, substantially as described.

Third, The combination of the stationary cam, *J*, and the fixed portion, *L*, of the bobbin-holder, substantially as described.

Fourth, The looping-hook, made and fitted to turn in the revolving and vibrating arm, *I*, as described, and provided with a pin or projection, *h*, operating in combination with a fixed stop, *m*, substantially as and for the purpose set forth.

The extension of the mandrel, *E*, forward of the rotating hook, as described, for the purpose of carrying the spring, *R*, and sleeve, *Q*, or its equivalent, by which the revolving and vibrating arm, *I*, which carries the hook is kept in contact with the cam from which it derives its vibrating motion.

Sixth, The adjustable pin, *r*, applied and operating substantially as described, in combination with the revolving and vibrating looping hook and the bobbin for the purpose set forth.

Seventh, Finding the cloth or material to be sewed by means of one or more smooth-faced angular projections, 14 14, on the feed bar, or its equivalent, and one or more ratchet-like wheels, *y*, attached to the presser, said wheels being arranged with the lowest portions of their peripheries, above the bottom of the presser foot, and the said projections pressing the material into one notch at a time of each wheel, and operating in combination therewith, substantially as described.

**24,938.**—E. L. Keeler, of Pittsburg, Pa., for an Improvement in Car Couplings:

I claim the combination of a beveled coupling-head, *c*, shaped substantially as described, with a spring, *e*, as a coupling for railroad cars, constructed and arranged in the manner described.

**24,939.**—David Kelsey, of Harper's Ferry, Va., for an Improvement in Sewing Machines:

I claim the horned eccentric, or cam, *L*, applied substantially as described, in combination with the vibrating pressure pad, *E*, and the feeding dog, sliding on the stem of said pad, and operated for the purpose specified, by means of a stud, *l*, or its equivalent attached to the needle-bar.

**24,940.**—B. F. Killam, of Braintree, Vt., for an Improvement in Tooth Keys:

I claim the hollow fulcrum, as described.

**24,941.**—O. H. King, of Salem, Iowa, for an Improvement in Harvesters:

I claim the arrangement and combination of the circular platform, *A*, rake, *B*, rod, *C*, guide-way, *E*, *E*, endless chain or belt, *G*, wheels, *F*, *F*, and pin, *H*, all constructed, arranged and operating together substantially as and for the purposes set forth.

[This invention consists in making the rake sweep a circular platform of the grain harvester by means of an endless belt. The belt carries the rake over the platform, so as to sweep off the grain at a point out of the track of the team, and then elevates the rake so as to clear the platform, and carrying it back and down ready for a new operation. This is certainly a very neat contrivance, and it seems to be well adapted for the purpose.]

**24,942.**—S. C. Lewis and F. P. Pfeleghar, of Whitneyville, Conn., for an Improvement in Revolving Fire-arms:

We claim, first, The center-pin, *EF*, made in two pieces, one of which is fitted to the rotating cylinder, and to a rotating recoil shield with fins, *b*, and has applied to it within the cylinder, a spring, *a*, and the other of which is fitted to slide and turn in the front part of the frame, and is capable of being locked to the frame, substantially as described.

Second, The dog, *n*, constructed and applied as described to constitute its own spring, and operating transversely to the hammer, in combination with a peripheral ratchet, *l*, *l*, substantially as and for the purpose set forth.

Third, The stop, *p*, constructed with a tooth, *p'*, in its front, and a projection, *u*, on its back, and applied and operating in combination with a spring, *v*, a ring of notches *m*, on the rear of the recoil shield, or cylinder, and a tooth, *u'*, on the tumbler, substantially as described.

Fourth, The recoil shield, constructed with a peripheral ratchet, *l*, a ring of notches, *m*, a central bore, *j*, and slots, *k*, *k*, substantially as and for the purpose specified.

**24,943.**—H. A. Lincoln and H. T. Douglass, of New Haven, Iowa, for an Improvement in Brakes for Railroad Cars:

We claim the combined arrangement described of brake shoes, truck wheels, equalizing beams and springs, the former being outside of the wheels, and so supported as to rise and fall practically with the wheels, while the equalizing beams support the springs, and the springs are arranged between the wheels, and transfer the weight to be carried to the equalizing beams, the several parts acting in combination, substantially in the manner and for the purposes specified.

**24,944.**—S. A. Lindsay, of Unionville, Md., for an Improvement in Harvesters:

I claim the combination of the hinged guide-piece, *S*, with the hinged platform, *T*, for the purpose of retaining the rake and the reels in their proper relative positions towards the platform, when the latter is raised or lowered, substantially in the manner described.

I also claim the combination of the bar, *3*, shaft, *5*, and the hinged bar, *f*, with the movable frame of the machine, and the finger-bar, *U*, for the purpose of raising and lowering the latter, without interfering with the free movements of the platform on its hinges, substantially in the manner described.

**24,945.**—Frederick Meyer, of Naperville, Ill., for an Improvement in Machines for Cutting and Binding Grain:

I claim, first, The combination of the movable gates, the sliding divider, and the movable platform, as described.

Second, The construction of the tongs, and the mode of operating them, as described.

Third, The tucker, *II*, for the purpose of fastening the free end of the band, substantially as described.

**24,946.**—Warren P. Miller, of Marysville, Cal., for an Improved Machine for Excavating and Grading:

I claim the use of the cylinders or wheels, *k*, *k*, for the purpose of depressing the chains, *h*, *h*, so as to give to the excavators, *i*, *i*, a proper inclination, and thereby facilitate the feeding and working of the same.

I claim the construction and arranging of the excavators attached to endless chains, worked in the manner above described, to wit, to fill and discharge, while traversing from one tumbler to the other, on the lower plane (from *A* to *B*), for the use and purpose of excavating and grading rail and turnpike roads, substantially as set forth.

**24,947.**—John A. Montgomery, of Williamsport, Pa., for an Improvement in Journal Boxes:

I claim a journal box, formed of a sphere or segment of a sphere, fitting into a cup or concave, and prevented from revolving with the shaft or journal by a pin and slot, as described, or their equivalent.

**24,948.**—J. T. Mudge, of Dayton, Ohio, for an Improved Washing Machine:

I claim arming the side of the tub, and the plunger, *F*, with round-headed knobs, or pins, to act on the clothes, substantially as described, and allow the water to escape freely as it is pressed out of the clothes being washed.

**24,949.**—E. T. D. Myers and C. F. Thomas, of Washington, D. C., for an Improved Apparatus for Tapping Water or Gas Mains:

We claim the method of drilling, tapping and inserting stop, or other cocks into cast-iron water or gas mains, gas-supply pipes, in the manner as set forth, or other manner substantially the same.

**24,950.**—J. R. Palmenbery, of New York City, for an Improved Branch-holder for Bonnet Stands:

I claim, as a new article of manufacture, a branch-holder, made and constructed in the manner substantially as described.

**24,951.**—Henry Pemberton, of East Tarentum, Pa., for an Improvement in Manufacture of common Salt:

I claim the combination of processes described for the purification of common salt, to wit: washing common salt procured by the evaporation of salt water containing chloride of calcium and other impurities, with a saturated solution of chloride of sodium, or brine rendered pure by the use of chemical re-agents, substantially in the manner described, and the repeated use, for that purpose, of the same brine, for an indefinite number of operations, by treating it, after each process of washing the salt, with suitable chemical agents, whereby it is restored to its original purity.

**24,952.**—Henry Pemberton, of East Tarentum, Pa., for an Improvement in Refining Coal Oils:

I claim recovering the sulphuric acid used from the residuum resulting from the process of the purification of coal oils, with sulphuric acid, by treating the residuum with water heated or caused to boil by steam or otherwise, substantially in the manner described.

**24,953.**—John G. Perry, of Kingston, R. I., for an Improved Meat Cutter:

I claim combining the revolving knives with a cylinder or block having studs on its surface, substantially as set forth.

**24,954.**—Phineas Pomeroy and J. G. Allen, of Middletown, Ohio, for an Improvement in Machinery for making Roofing Cement:

We claim the employment of the double-walled tank, *c*, in combination with the hollow metallic cylinders, *l*, and valves, *p*, all being constructed and arranged to operate substantially as and for the purpose set forth.

**24,955.**—Jesse Pruette, of Aurora, Ill., for an Improvement in Carriage Hubs:

I claim the enlargement, *G*, upon box, *B*, having an annular flange, *a*, for the purposes specified, in combination with the nut, *F*, and its flange, *b*, when the same are both arranged substantially as and for the purposes set forth.

[An annular flange, with a concave recess formed on its inner surface, is cast upon the but-end of the box, and this is driven into the hub. On the opposite end of the box a metallic nut is screwed, having a flange upon its inner surface which projects into a corresponding cavity in the hub.]

**24,956.**—Lyman P. Rood, of Deposit, N. Y., for an Improved Machine for Turning Hollow-ware:

I claim the combination of the rotating mandrel, *B*, with the adjustable slide, *F*, provided with the tool-rest, *G*, and cutter, *II*, arranged as and for the purpose set forth.

**24,957.**—Andrew Shogren, of Chicago, Ill., for an Improvement in Sickle-guards for Harvesters:

I claim the cutter-guard, *C*, constructed in the manner described, in combination with the guard-socket, *B*, and wedge-shaped bolt, *D*, substantially as described.

**24,958.**—Daniel C. Smith, of Tecumseh, Mich., for an Improvement in Corn-huskers:

I claim, first, The combination of forceps, *A*, lever, *B*, stop, *C*, spring, *F*, and post, *G*, in the manner and for the purposes specified. Second, I claim the combination with the forceps, *A*, of the slotted post, *M*, nut, *N*, and fork, *O*, in the manner and for the purposes specified.

**24,959.**—John S. Snider, of Lancaster, Ohio, for an Improvement in Seeding Plows:

I claim the arrangement of the swinging frame, *F*, wheel, *W*, crank-shaft, *A*, with the hopper, *H*, and mold-board, *M*, together with the devices connecting said parts, so as to operate as set forth.

**24,960.**—Geo. A. Stanley, of Cleveland, Ohio, for an Improvement in Machinery for Molding Candles:

I claim, first, The moving of the molds any distance lengthwise of the candles, to detach the molds from the candles formed in them, and to withdraw the molds from the candles and place the jaws of the clutches around them.

Second, Moving the molds by the weight of the molds, and boxes containing the molds, to adjust the jaws of the clutches to the candles, and attach the clutches firmly to the candles, so that they may be raised at the same time at which the molds are returned empty to their first position.

**24,961.**—Richard A. Stewart, of St. Bernard Parish, La., for an Improvement in Apparatus for Defecating Sugar:

I claim the combination of the retort, the vacuum cylinder and the receiver, substantially in the manner and for the purpose set forth, and these I also claim in combination with the steam boiler, substantially operating as described and for the purpose set forth.

**24,962.**—H. W. Stillman, of Port Washington, Wis., for an Improvement in Brick Machines:

I claim the combination of the revolving molds, *D*, feeder, *G*, and plate, *I*, when arranged and operated in the manner described for the purpose specified.

[This invention consists in the employment of a series of rotating molds, provided with movable bottoms operated by eccentrics, in connection with a feeder and a resisting plate, whereby a very compact and efficient machine is obtained.]

**24,963.**—Samuel Taggart, of Indianapolis, Ind., for an Improvement in Flour-packers:

I claim, first, The cap, *G*, with cap, *G*, *G*, when operated in connection with the clutch-wheel, *G*, and shaft, *D*.

Second, The cam, *V*, in combination with the barrel-lifter, *T*, when constructed and operated as and for the purposes set forth.

Third, The combination and arrangement of the friction-brake, *Q*, rod, *K*, walking-beam, *C*, packing-shaft, *D*, and barrel-lifter, *T*, when the whole is combined and operated as and for the purposes set forth.

**24,964.**—N. G. Thom, of Cincinnati, Ohio, for an Improved Machine for Pointing and Threading Wood-Screws:

I claim, first, As a part of my invention, the combination of a rotating head containing two or more spindles or blank-holders, revolving round a central point with an intermittent motion, with an apparatus for pointing and threading screw-blanks, so arranged and operated that while one blank is being pointed, and undergoing the other operations necessary thereto, another blank is being threaded by another part of the same machine.

Second, I claim, in combination with an apparatus for pointing and threading screw-blanks, simultaneously, or nearly so, by the same machine, the apparatus so constructed and operated that while the spindles are rotated, or changing positions, the threading cam or other device for operating the threading tool and its connections remains stationary, and when the motion of the spindles around the central point is arrested, the other part, and all necessary parts of the machine, recommence motion.

Third, I claim the spring-brake, *C'*, so constructed and operated

that when the spring is being depressed to withdraw it from the notch in the plate, *S*, it acts as a brake upon the periphery of the plate, *T*, to arrest its motion, and the parts connected with it, at the same time relieving the plate, *S*, and allowing it to revolve with the spindles.

Fourth, I claim the quadrant-shaped, grooved arm, on the pointing tool stock, which, in connection with the spring, *F*, or its equivalent, receives the blank from the hopper, and conveys it to the grippers, and supports it while being pointed, substantially as described.

Fifth, In combination with the quadrant, I claim the reciprocating motion of the hopper for the purpose of depositing the blanks in the quadrant, to be conveyed to the grippers.

Sixth, I claim the triangular grooved cam, *J*, in combination with the hopper, *L*, so constructed that when moved in one direction by the action of the tool stock or otherwise, the hopper is depressed, and when moved in a contrary direction the hopper is elevated, for the purpose of depositing the blanks in the quadrant, or other mechanical device for receiving them.

Seventh, In combination with an apparatus for threading and pointing screw-blanks by the same machine, I claim the worm, *F*, when combined with the gears, *b*, *c* and *e*, or equivalent arrangement, by which the revolution of the worm causes the spindles to rotate round a central point, substantially as described.

Eighth, I claim the rocking feed-levers, *o*, *o'*, constructed substantially as described, for the purpose of regulating the depth of cut of the threading tool.

Ninth, I claim the ratchet, *S*, and revolving cam, *r*, when combined with the feed-lever, *E*, substantially as described, for the purpose of raising the cutting tool out of the thread, in its backward motion, and increasing the depth of cut of the threading tool.

Tenth, In combination with the rod for opening the grippers, I claim the movable nut, *u'*, which acts upon the thread in the edge of the rod, *Z*, to withdraw the cone and release the screw.

Eleventh, I claim the traversing arm, *e'*, in combination with the spring lever, *f'*, or its equivalent, for the purpose of removing the screw from the grippers when released.

Twelfth, I claim the sliding cam, *w'*, in combination with the threading cam, for the purpose of removing the screw from the grippers and releasing it, substantially as described.

Thirteenth, I claim the arm, *m'*, on the threading tool stock, in combination with the threading tool and rod, *n'*, or its equivalent, for the purpose of giving the proper form to the thread, and curving the shape of the screw.

Fourteenth, In combination with the spindles or blank-holders, I claim the gears, *f''*, *g''*, *h''*, on the spindles, for the purpose of equalizing their motion and causing them to revolve round the shaft, *c*, while changing their position, whether the driving belt rests or acts on one or both the spindles.

**24,965.**—Horace Vaughn, of Providence, R. I., and Wm. Hutton, of Baltimore, Md., assignors to H. Vaughn aforesaid, for an Improvement in Lubricating Compounds:

We claim "the cooling compound solution," as fully described.

**24,966.**—Allen Wilson and George C. Fletcher, of St. Thomas, Mo., for an Improvement in Hemp Brakes:

We claim the arrangement and combination of the plates, *M*, *M'*, *N*, *O*, each pair of plates, *M*, *M'*, *N*, *O*, moving in opposite directions through the medium of double cranks, upon shafts, *I*, *L*, as and for the purposes shown and described.

[In this invention toothed rollers and reciprocating and stationary plates are used, either with or without an endless apron, these parts being all so arranged that they will operate together, and first break the woody portion of the hemp and then separate it from the fiber, the work being performed at one operation.]

**24,967.**—D. J. Wilcoxson, of Milan, Ohio, for an Improved Ship's Hoisting Apparatus:

I claim, first, Arranging the pawl and ratchet substantially as described, so as to allow the hoisting shaft to turn backward in lowering without disconnecting the pawl from the ratchet.

Second, Forming the connection between a friction pulley and hoisting shaft, by means of a pawl and ratchet, substantially so that the friction pulley is only in connection with the shaft while lowering.

Third, The combination of the friction pulley, friction brake and friction lever, arranged substantially as described, so that by the movement of the brake the friction pulley is released to revolve with the shaft, and power of the brake simultaneously applied to the pulley to regulate the rotation of the shaft in lowering.

Fourth, Combination of the vibrating pawl plates, *G*, cam levers, *H*, and the eccentrics, arranged as described, to give motion to the hoisting shaft.

**24,968.**—Wm. F. Warburton, of Philadelphia, Pa., for an Improvement in the Manufacture of Hats:

I claim the process described of perforating the bodies of hats, by means of heated metal points, for the purpose specified.

**24,969.**—Augustus Watson, of Walnut Run, Ohio, for an Improvement in Mole Plows:

I claim suspending the coupler, *C*, to the lever, *D*, and guiding it between rollers, so that it may be raised or lowered independently of the beam or frame of the plow, substantially in the manner and for the purpose described.

I also claim making one or both of the beam plates, *G*, *H*, adjustable, for the purpose of adjusting the position of the coupler so as to give it the proper tip or inclination, substantially in the manner and for the purpose described.

I also claim, in combination with the beam plates, and the coupler, *C*, the groove guide rollers, *f*, *g*, for the purpose of guiding the coupler in its vertical motion, and preventing any side or twisting motion of the same, substantially as described.

I also claim, in connection with the coupler and mole, the pivoted tongue, *p*, substantially in the manner and for the purpose described.

I also claim, in combination with the coupler and the mole, the link, *P*, whose ends are secured by a screw sleeve, for the purpose described.

**24,970.**—Robert D. Dwyer (assignor to A. B. Sands and Daniel Sands), of New York City, for an Improvement in Manufacture of Lint:

I claim the new article of manufacture described, being surgeon's lint, produced directly from new flax, in the manner substantially as set forth.

**24,971.**—John G. Ernst (assignor to himself and S. R. Slaymaker), of York, Pa., for an Improved Machine for Bending Plow-handles:

I claim, first, The employment or use of the form block, *H*, fitted in the frame, *A*, with the chain, *R*, attached with or without the weight, *c'*, in connection with the roller, *P*, and the toothed segments, *o*, *o*, and stop, *N*, the latter being attached to the bed, *K*, in carriage, *B*, the whole being arranged to operate as and for the purpose set forth.

Second, The arrangement of the lever, *h*, connected with clutch, *g*, the connecting bar, *j*, and the lever, *k*, attached to shaft, *G*, in connection with the rod, *l*, and lever or button, *f'*, substantially as shown, whereby the operation of the machine, so far as the gigning back motion is concerned, is rendered automatic throughout.

Third, The movable rack, *C*, when adjusted and arranged substantially as shown, with the wheel, *F*, for the purpose of stopping the feed or forward movement of the carriage, *B*.

[This invention consists in a peculiar mechanism, whereby the timber, as it is bent, is "upset," and so acted upon that its strength will not be impaired or injured by the process of bending. The invention is designed to be self-acting or automatic in its operation, so that the timber will be subjected to the proper action without any care or attention on the part of the operator except the placing of timber in the machine, and the removal of finished work therefrom.]

**24,972.**—James A. Hamer, of Reading, Pa., assignor to himself and Norris Maris, of Kimberton, Pa., for an Improvement in Brick Molds:

I claim, first, The construction, combination and arrangement of

the operating parts of the brick mold, substantially as set forth, for the purpose described.

Second, The combination of the sides and partitions of the mold, operating substantially as and for the purpose described.

Third, The combination of the levers, D D, with the arms, F F, and pins, J J, for operating the sides and partitions of the mold, as and for the purpose set forth.

**24,973.**—George L. Jencks (assignor to himself, George Kendall and John Hendrick), of Providence, R. I., for an Improvement in Sewing Machines:

I claim, first, The combination in a single thread sewing machine of a perforated barbed needle, which is arranged obliquely to the feed movement of the cloth or material being sewed, with a pair of nippers or other equivalent device, which will, as the inclined needle is operating to assist in forming the stitch, retain and present the thread to the needle, in a manner to allow the necessary loop to be formed, shortened, and drawn into or tight on the cloth, substantially as and for the purpose set forth.

Second, The combination with a barbed needle of the spring nippers thread-guide, and adjusting nipper-closing bracket, when constructed, arranged and operating substantially as and for the purposes set forth.

**24,974.**—Danforth Johnson (assignor to B. B. Worden and Wm. Cadwell), of Chicago, Ill., for an Improved Clothes-dryer:

I claim the employment of flexible braces, H H, in combination with the freely-sliding collar, E, on the spindles, A, for the purpose specified.

**24,975.**—Wm. Johnson (assignor to himself and Eibert Schumacher), of Milwaukee, Wis., for an Improvement in Bank Locks:

I claim, first, Operating the regulator wheels or guard plates by the screw pins, which are susceptible of being changed in the holes of the plates, and in relation to each other, as set forth.

Second, I claim the tapered indicators, stem and beveled plate of the stem, fitting into the tapered recesses, as and for the purposes set forth.

Third, In combination with a series of regulator wheels or guard plates, operated as described, I claim the means for indicating the position of such plates, constructed and arranged as set forth.

Fourth, I claim the cock-wheel, or toothed disk, in combination with the tumbler and the regulator wheels or guard plates, as described.

**24,976.**—Robert Poole (assignor to himself and G. H. Hunt), of Baltimore, Md., for an Improvement in Casting Chilled Plates:

I claim making the chill for casting plates in sections, when said sections are secured to a bed plate in such a manner as to leave spaces between them, which are filled with sand or other yielding material, substantially in the manner and for the purpose described.

**24,977.**—John B. Powell (assignor to himself and Geo. B. Frick), of Philadelphia, Pa., for an Improved Machine for Winding-up Clocks:

Without confining myself to any specific arrangement of parts, I claim the spring lever, D, spring pawl or catch, C, and ratchet wheel, B, with the supplementary lever, H, and permanent pin, e, or their equivalents, when applied substantially in the manner set forth, to the winding-up of clocks or other machines, in which a spring or weight is used as a prime mover.

#### RE-ISSUES.

**John Fairclough, of Louisville, Ky., for an Improvement in Balancing Millstones.** Patented Dec. 21, 1858:

I claim the employment or use of weights, i, placed within boxes or recesses in the back of the stone, and arranged substantially as described, so that they may be adjusted vertically, and more or less be used in each box or recess to admit of the balancing of the stone or runner, both while in motion and at rest.

[An engraving of this will be found in another portion of the paper.]

**Jahaziah S. King, of Raynham, Mass., for an Improved Nail Machine.** Patented Oct. 20, 1857:

I claim making cut nails in such a manner that each nail will be seized the instant after it is cut from the nail plate, and be compressively operated upon at the point thereof, in the manner as specified, to bring the flat point of said nail to an equal-sided sharp point, or to substantially the same character of point that is ordinarily given to wrought nails.

**Henry E. Pierce, of Charlemont, Mass., for an Improved Machine for Matting the Ends of Match Blocks.** Patented Jan. 10, 1854:

I claim matting the ends of match blocks by pressure of a roller or rollers, for the purpose set forth, and in this claim I wish to be understood that I do not confine myself to the precise arrangement of the parts described, but shall vary them at pleasure, while I attain the same ends by means substantially the same.

**Stephen H. Tift, of Morrisville, Vt., for an Improved Clothes-dryer.** Patented July 20, 1858:

I claim the combination of the slotted perforated hub, B, and slotted, bored cap-hub, C, with the arms, D, and braces, E, connected with the hubs by wires as described, and the arrangement the same with the shaft, A, collar, F, and ratchet catch, G, as specified.

**George Watt, of Richmond, Va., for an Improvement in Plows.** Patented Feb. 9, 1858:

I claim constructing mold-board and land-side of cylindrical surfaces of equal diameters, intersecting along the cutting edge of the plow, in combination with the standard, S, curving landward from the top of the mold-board to a position nearly over the base of the land-side, as set forth.

#### ADDITIONAL IMPROVEMENTS.

**George Watt, of Richmond, Va., for an Improvement in Plows.** Patented Feb. 9, 1858:

I claim the combination of the eccentric roller, r, beam, B, notches, i, and cuff, f, substantially as set forth.

#### History of the Scientific American and Important Information to Patentees.

We have printed a supplementary edition of the SCIENTIFIC AMERICAN, in which there is a history of its rise and progress, with illustrations of the building, externally and internally, showing the spacious rooms in which our immense patent business is conducted, and with life-like representations of the artists, engineers and specification writers at their daily labors. The same paper contains information on the many intricate points arising in patent law and practice, and comprises the best popular treatise on the subject ever published; it should be in the hands of all who are interested either in procuring, managing or using patented inventions. The legal information contained in this paper is the result of FOURTEEN YEARS' experience as patent solicitors, and it cannot be found in any other treatise on patent law. It also contains information in regard to Foreign Patents and Extensions. It is published in octavo form, sixteen pages, and mailed upon receipt of two three-cent stamps. Address MUNN & Co., publishers of the SCIENTIFIC AMERICAN, New York City.



**J. G. O. B., of N. Y.**—Several patents have been granted for machines for making horseshoe nails. We cannot refer you to any one who is now using such machines.

**H. J. G., of N. Y.**—No work has ever been published, so far as we know, upon the subject of lubricating oils.

**G. F. & W. J. P., of N. Y.**—A cannon can be discharged just as often as it is loaded. Some artillerymen have loaded by the muzzle and fired five times in one minute.

**M. K., of Ind.**—A piece of platinum or a piece of brass, such as a pin, placed in the center of a flame, increases the light when it becomes white, by the increased surface of reflection which is presented.

**W. T. G., of Conn.**—Blocks of oak wood, placed in a boiler, are liable to act chemically upon the iron and injure it; but we do not believe they can be so detrimental to the metal as the scale which they prevent forming, or which they assist to remove when once formed.

**S. W. E., of Ohio.**—Prussian blue can be dissolved and held in solution. Its components can also be held in solution without combining, but not for the purposes of making writing fluid.

**B. H. M., of N. H.**—We are not skilled in peculiarities of the banjo, and are therefore not able to answer your inquiry. About all we know respecting it is that there is such an instrument, and when well thumbed, it gives out tolerable music.

**J. H. B., of —.**—A series of magnets may be so arranged as to give motion to a slender bar of iron suspended on a pivot, but no useful motor can be constructed by such an arrangement.

**S. G., of N. Y.**—The New York State Agricultural Fair will be held this year at Albany, in the first week of October.

**W. J. McC., of Tenn.**—If you can obtain glazed earthenware water pipes at a moderate cost, use them in preference to lead or iron for conducting your spring water. We are not practically acquainted with the pump to which you refer.

**J. P. H., of Va.**—Self-operating fans appear to be what you inquire after in your letter, to keep off the mosquitoes and ventilate your rooms. You can get such fans made in this city; they are moved by springs like clockwork.

**G. W. L., of Mass.**—The prices named in our review of the markets are the wholesale prices.

**A. G., of Ohio.**—A ball of lead and one of wood, each six inches in diameter, will fall in vacuo with the same velocity, but not in the atmosphere; because the resistance of the atmosphere is equal on both, while their momentum varies with their relative gravities.

**J. P. H., of Vt.**—American locomotives are better adapted for our railroads than English engines, but the latter are better for the roads in England. Some (we cannot say how many) of Norris' locomotives were imported into England. The British Parliament never passed an act prohibiting the importation of American locomotives.

**J. E. S., of N. Y.**—To make the auro-cyanide of potassium for electro-gilding, place a piece of pure gold, as the positive pole, in a solution of cyanuret of potassium, using at the same time a small negative pole. By boiling the oxyd of gold (obtained by precipitation from an aqua regia solution) in a solution of cyanuret of potassium, you can also make the gilding fluid. Alloys of gold cannot be uniformly precipitated in electro-gilding. Use platinum tips for the wires of your battery.

**N. C., of N. Y.**—The united steam power of Great Britain alone, employed in different ways (every engine having been constructed since the improvements of Watt were first made known), is estimated as equivalent to the manual labor of upwards of four hundred millions of men, or more than double the number of males supposed to inhabit the globe. It is very much less in this country. The facts and the results are astonishing, when we consider the wide application of this mighty motor.

**G. S. K., of N. Y.**—Steam in condensing engines is condensed by a jet of water flowing in a shower into the condenser. The work entitled "The Vestiges of the Natural History of Creation" is regarded by scientific men as very unscientific, and unreliable in its conclusions.

**W. D. F., of Pa.**—We are glad you find the article on cone pulleys so useful, practically. There is no practical treatise on the subject with which we are familiar. The information we gave was original with us. We will send you the formula you mention. We do not think it can be found in any mathematical work extant.

**E. S. R., of La.**—In our next issue we shall publish such an apparatus as you refer to.

**D. B. W., of N. H.**—To re-galvanize an old zinc-dipped chain for a pump, steep it in dilute sulphuric acid until all the old zinc is removed, then scour off the rust with hot water and sand. It is now ready for dipping in a solution of sal-ammoniac, after which it is to be dipped into molten zinc, kept in a vessel with a stratum of ground glass floating on its surface, to prevent the zinc from evaporating in fumes.

**T. T., of N. C.**—If an individual obtains a patent for a distinct thing or feature, the grant protects him in the use thereof, irrespective of other devices. For example: If his patent is for an improvement in plow-handles, he has the right to apply them to every description of plows. But if his patent only covered the use of the handles in combination with a beam and clevis of peculiar form, then the grant would not protect him in the application of the handles to any other beam or clevis.

**L. & C., of N. Y.**—Parties who expect to receive replies to their letters should have the courtesy to sign their names to them.

**S. S., of Ind.**—If you dip a cotton cord in a solution of chlorate of potash, and dry it, then moisten it with a paste of common gunpowder and dry it, you will obtain a fuse which will ignite rapidly, to fire a distant train. This fuse must be kept quite dry. Common gunpowder paste will also make a fuse (but somewhat slower) of itself.

**RECEIPTS.**—When money is paid at the office for subscriptions, a receipt for it will always be given; but when subscribers remit their money by mail, they may consider the arrival of the first paper a *bona fide* acknowledgment of our reception of their funds.

**PATENT CLAIMS.**—Persons desiring the claim of any invention which has been patented within the last fifteen years, can obtain a copy by addressing a letter to this office, stating the name of the patentee, and date of patent when known, and enclosing \$1 as fee for copying.

**BINDING.**—We would suggest to those of our patrons who have the last volume of the SCIENTIFIC AMERICAN complete, and desire to have it bound, that they had better send their numbers to this office, and have them bound in a uniform style with their previous volumes. Price of binding, 75 cents.

#### Money Received

At the Scientific American Office on account of Patent Office business, for the week ending Saturday, Aug. 6, 1859:—

A. G. J., of La., \$30; W. R. A., of Wis., \$30; K. & C., of Pa., \$35; F. M. R., of Pa., \$20; R. F. H., of Ill., \$25; J. W., of N. Y., \$25; S. & J. H. B., of Ill., \$30; M. B. H., of Miss., \$30; M. D. D., of N. Y., \$30; J. D., of Ga., \$30; D. B., of Ind., \$30; J. H. F., of Ohio, \$30; E. D., of La., \$30; G. W. B., of N. Y., \$37.50; J. M., of Ill., \$25; J. B. F. P., of Mo., \$12; G. W. C., of Ill., \$25; H. H. B., of N. J., \$30; J. L. B., of Ohio, \$25; S. B., of N. Y., \$25; K. V., of Mass., \$145; J. T. T., of Texas, \$10; H. P. J., of Conn., \$30; W. M. H., of Vt., \$30; G. & M., of Ill., \$10; W. P., of N. Y., \$30; F. S. P., of N. Y., \$30; W. T., of N. Y., \$25; G. & P., of Ky., \$25; W. H. G., of Ill., \$25; C. E. R., of N. Y., \$30; J. F. H., of N. Y., \$30; J. R., of Ohio, \$30; N. C., of Ohio, \$25; H. & T., of N. Y., \$55; A. K., of Ill., \$55; A. H. P., of Mass., \$30; S. L. O., of Conn., \$25; J. L. G. W., of Mich., \$30; S. & L. R., of Ind., \$30; R. H., of Vt., \$16; H. O. A., of La., \$30; H. M., of Va., \$30; L. H., of N. Y., \$27.67; E. B., of Conn., \$35.

Specifications, drawings and models belonging to parties with the following initials have been forwarded to the Patent Office during the week ending Saturday, Aug. 6, 1859:—

R. H., of Vt.; F. McD., of N. Y.; W. A. McD., of N. J.; J. D., of Ga.; S. & J. H. B., of Ill.; F. H., of Ill.; J. W., of N. Y.; K. & C., of Va.; F. M. R., of Pa.; W. T., of N. Y.; W. H. G., of Ill.; J. R., of Ohio; G. W. C., of Ill.; G. C., of Ill.; S. B., of N. Y.; J. L. B., of Ohio; E. D., of La.; N. C., of Ohio; B. A., of Maine; G. R. C., of Pa.; H. H., of Mo.

#### Rates of Advertising.

Thirty cents per line for each and every insertion, payable in advance. To enable all to understand how to calculate the amount they must send when they wish advertisements published, we will explain that ten words average one line. Engravings will not be admitted into our advertising columns; and, as heretofore, the publishers reserve to themselves the right to reject any advertisement sent for publication.

**KNITTING MACHINES, CIRCULAR AND** straight, and machine-knitting needles, of all sizes and gauges, on hand and made to order. Address WALTER AIKEN, Franklin, N. H. 722\*

**WANTED—VOLUMES I, II AND III OF THE** "SCIENTIFIC AMERICAN," either bound or in numbers. Persons having either volume complete (bound or in numbers), will please address the subscriber, stating terms. JOHN P. NESSER, Albany, N. Y. 1\*

**J. B. SHERMAN, AGENT, GREENVILLE, S. C.**—Dealer in stoves, pumps, agricultural implements, housekeeping wares, cabinet furniture, tin and iron goods, lamps, &c., requests manufacturers and wholesale dealers to send him catalogues and priced lists of their wares. 1\*

**THE HERALD OF HEALTH—THE AUGUST** number of the "Water Cure Journal," now ready, contains:—Theory and Practice of Hydrophobia; Reports of Cases; Water Cure in Ohio; Letter from Harriet N. Austin; Medicinal Fertilizers; Dysentery, or Bloody Flux; Water Cure in Paris; Water Cure in Oregon; Putrid Sore Throat; The Prevailing Malady; Summer Complaints; Interesting Experience; Fellow-travelers, &c. Only \$1 a year, or 10 cents a number. A good time to subscribe. Address FOWLER & WELLS, 308 Broadway, New York. 72

**PHOTOGRAPHY AND THE FINE ARTS.—C.** J. FOX, 681 Broadway, New York, invites the attention of manufacturers, engineers and others, to his varied stock of photographic apparatuses, invaluable for rapid and accurate copying of machinery, models, drawings, &c. Complete outfits from \$25. Catalogues sent for one stamp. 72\*

**MILLER & BENTON'S PATENT BELT COUPLINGS.**—The best and cheapest article in use for uniting machinery belting, requires no bending or alterations of any kind, and will last for any number of belts. See SCIENTIFIC AMERICAN of July 3, 1858. Send for a circular containing cuts, certificates, &c. Agents wanted. MILLER & BENTON, No. 11 Platt-street. 1\*

**MATHEMATICAL INSTRUMENTS FOR** SCHOOLS, ARCHITECTS AND CIVIL ENGINEERS.—Microscopes and Microscopic Objects; Magic Lanterns and slides in great variety, Scriptural, Astronomical and Humorous; Stereoscopes and Stereoscopic Pictures, on glass or paper; Landscape or Claude Lorraine Mirrors for viewing clouds, scenery, &c.; Surveying Compasses, Thermometers, Rain Gages, Barometers, Electrical Machines, Galvanic Batteries, Surveying Chains, &c. McALLISTER & BROTHER (established in 1790), No. 728 Chestnut-street, Philadelphia. A priced and descriptive catalogue—108 pages, 200 illustrations—furnished gratis on application and mailed free of charge to all parts of the United States. 1

**EXHIBITION OF A CIGAR-MAKING MACHINE.** The inventor of this valuable addition to modern industry, Louis Beauche, of Paris, wishes all persons who are interested in this branch of manufacture, and capitalists, to communicate their wish to examine it to him, by letter, and he will be most happy to afford them an opportunity. Address No. 79 Cedar-street. Patents for the United States, Cuba, Porto Rico, Spain and Portugal are for sale. 1\*

## PATENT EXTENSIONS.—ALL PATENTS FOR

Inventions, granted by the United States during the year 1859, will expire by their own limitations during the current year (1860) UNLESS EXTENDED ACCORDING TO LAW. The statute provides for the extension of Patents for an additional term of SEVEN YEARS, the grant being made to the inventor himself, or if deceased, to his heirs and administrators. The extension may be granted solely to the benefit of the inventor or his heirs. Assignees or owners of rights under the first term of the Patent have no rights whatever in the extended term. The inventor or his heirs may, however, sell their interests in the Extension prior to the grant thereof, in which case the Extended Patent, when granted, becomes the exclusive property of such purchaser. Applications for Extensions must be made at the Patent Office at least 60 days prior to the expiration of the Patent. The undersigned, having had great experience in Patent business, will promptly prepare the various documents and prosecute Extension cases on moderate terms. For further information address  
MUNN & CO., Solicitors of Patents,  
No. 37 Park-row (Scientific American Office), New York.

**PECK'S PATENT DROP PRESS.—THE MOST** perfect machine in use for the manufacture of silver, copper or tin ware, spoons, jewelry, &c. Manufactured by the patentee.  
MILLO PECK & CO., New Haven, Conn.

**A PRACTICAL COMPANION FOR THE TIN,** SHEET IRON, COPPER AND BOILER-PLATE WORKERS. With Plates and Illustrations. Sent to any part of the United States free of postage, on the receipt of One Dollar. Circulars of contents sent free on application. BLINN & BATTLE, Detroit, Mich. 5 4\*

**APPEALS BEFORE THE JUDGES OF THE** U. S. District Court, from the final decisions of the Patent Office, in Rejected Cases, Interferences, &c., are prosecuted by the undersigned on moderate terms.  
MUNN & CO., Solicitors of Patents,  
No. 37 Park-row (Scientific American Office), New York.

**BALL'S OHIO MOWER AND REAPER, AS IM-** proved for 1859, is the best and most saleable one made in the United States. For shop rights, Territory or Franchises, apply to  
E. BALL, Canton, Ohio.

**LEAVITT & CO., COMMISSION AGENTS FOR** the Purchase and Sale of Machinery, Implements and Tools of all kinds. Orders by mail faithfully attended to. No. 37 Park-row (over the Scientific American Office), New York. 6 1t\*  
[From the Scientific American, July 2, 1859.]  
Messrs. Leavitt & Co. are gentlemen characterized for honest dealing.

**SPALDING'S PREPARED GLUE.—SAVE THE** pieces—Economy—Dispatch! "A stitch in time saves nine." As accidents will happen even in well regulated families, it is very desirable to have some cheap and convenient way for repairing furniture, toys, crockery, &c. Spalding's Prepared Glue meets all such emergencies, and is always ready and up to the sticking point. It is just the article for a cone, shell and other ornamental work. It is used cold, being chemically held in solution, and possesses all the valuable qualities of the best cabinet-maker's glue. Useful in every house.  
N. B.—A brush accompanies each bottle. Price, 25 cents. Wholesale depot, No. 30 Platt-street, New York. Address H. C. SPALDING, box No. 3,600 New York. Put up for dealers in cases containing four, eight and twelve dozen, a beautiful lithograph show-card accompanying each package. Sold by all prominent stationers, druggists, hardware and furniture dealers, grocers and fancy stores. Country merchants should make a note of Spalding's Prepared Glue, when making up their Fall list.

**GREAT CURIOSITY.—WE HAVE ONE OF THE** greatest curiosities and most valuable inventions in the known world, for which we want agents everywhere. Full particulars sent free.  
SHAW & CLARK, Biddeford, Maine.

**BANCA TIN, INGOT COPPER, SPELTER, LEAD,** Antimony, Babbitt Metal, &c. Mount Hope Cut Nails, Ames' Shovels and Spades, for sale by JOHN W. QUINCY & CO., No. 99 William-street, New York. 14 13c5w\*

**HARRISON'S GRIST MILLS.—20, 30, 36 AND** 48 inches diameter, at \$100, \$300, \$500 and \$1000, with all the modern improvements. Also, Portable and Stationary Steam-engines of all sizes, suitable for said Mills. Also, Bolters, Elevators, Belting, &c. Apply to S. C. HILLS, No. 12 Platt-street, New York. 1 c3w\*

**INSTRUMENTS.—CATALOGUE CONTAINING** 250 illustrations of Mathematical, Optical and Philosophical Instruments, with attachment of a large sheet representing the Swiss instruments in their actual size and shape, will be delivered, on application, to all parts of the United States, by sending 12 cents in postage stamps.  
C. E. AMSLER,  
No. 635 Chestnut-street, Philadelphia.  
Catalogue of Stereoscopic Pictures is furnished gratis on application. 1 4c0w\*

**MEN OF MEANS DISPOSED TO ENGAGE IN** business or to invest in profitable mechanical enterprises, may generally learn of good opportunities, with reliable information concerning them, on application to  
LEAVITT & CO.,  
No. 37 Park-row (over Scientific American Office), New York.

**YOUR NAME IN GILT LETTERS (ADHESIVE).** Size 1 inch, one cent each; 2 inches, two cents; 3 inches, three cents, &c., with red stamp to pay return postage. Grand Chance for Agents!—12 Alphabets, one inch, for \$1; two inch, for \$1; three inch, for \$1—assorted colors. Address  
GEORGE K. SNOW, Boston, Mass.

**WARTH'S SELF-ACTING WOOD-TURNING** LATHES.—The best and most practical now in use; one boy will accomplish the work of four men. State and County rights for sale. Address A. WARTH, care of W. H. Bertling, No. 23 Chambers-street, New York, or the manufacturers, who have machines of all sizes on hand. Also a general assortment of machinists' tools. Circulars sent. Address CARPENTER & PLASS, No. 479 First-avenue, New York. 6 3\*

**STEAM BOILERS FOR SALE.—NEW AND** Second-hand Boilers, from One to Twenty-horse Power. Enquire or address  
WM. FINNEY & CO.,  
No. 167 Water-street, Brooklyn, L. I.

**PATENT SUBMARINE ELECTRIC SAFETY-** FUSE TRAIN.—For Military and Civil purposes. It travels a mile in four seconds under water or ground; leaves no fire or smoke behind. For sale at No. 165 Broadway, New York. Inquire of  
E. GOMEZ.

**FOR SALE—FOUR VOLUMES OF THE "SCI-** ENTIFIC AMERICAN"—XI, XII, XIII, XIV. Address  
L. H. STRENG, Grand Rapids, Mich.

**FOR SALE—THE RECIPES, TRADE MARK,** stock and good-will of "Durno's Catarrh Snuff" business. Address  
JAMES DURNO, Albany, N. Y.

**500 AGENTS WANTED.—TO ENGAGE IN** an honorable business which pays from \$3 to \$6 per day. For particulars address M. M. SANBORN, Brasher Falls, N. Y. 7 2\*

## BUTCHER'S IMPERIAL CAST-STEEL FILES—

The subscribers keep constantly on hand a very large assortment of the above celebrated files, which are acknowledged to be unequalled in quality, and to which the attention of railroad companies, engineers and machinists is invited.  
BARTON & SCOTT,  
No. 18 Cliff-street, New York.

## RARE CHEMICALS, METALS, SOLUBLE

Glass, Oxyds, Uranium, Cobalt, Manganese, Platina, Aluminium, Bismuth, Zafre, Fluor-spar, Asbestos, French Chalk, Insect Powder, Nitrates of Strontia and Baryta, Chlorate of Potash, Bi-sulphide of Lime, Plumbago, Best Oil, Cochine, Rye, Gin and Rum, for sale by Dr. LEWIS FRECHTENGANGER, No. 143 Maiden-lane, New York. N. B.—Treatise on fermented liquors and 1,000 directions. 2 10\*

**LUCIUS W. POND, MANUFACTURER OF SU-** perior Planing-machines for Iron, Engine Lathes and Machinists Tools generally. Address L. W. POND, Worcester, Mass. 2 16t\*

## IRON PLANERS, ENGINE LATHES, AND OTHER

Machinists Tools, of superior quality, on hand and finishing, and for sale low; also Harrison's Grain Mills. For descriptive circular, address New Haven Manufacturing Co., New Haven, Conn. 2 13

## STEAM COTTON FACTORY FOR SALE.—THE

subscriber offers, low for cash or approved paper, his large and well-appointed cotton factory at Herberville, Hardon county, Tennessee; also a large tract of woodland surrounding the factory. It is situated near the best cotton and provision markets of the South, and within two miles of Tennessee river, which is always navigable. Refer to James Gillespie, of the Machinist Association, Paterson, N. J.; J. T. Dawdall & Co., St. Louis, Mo.; or the subscriber at Herberville, Tenn. [4 7\*] C. L. HERBERT.

## CHRONOMETERS, FINE WATCHES, NAUTI-

CAL AND ASTRONOMICAL INSTRUMENTS, &c.—D. EGGERT & SON, No. 293 Pearl-street, New York, offer on favorable terms first-class Marine, Siderial and Pocket Chronometers; also, plain and finer quality of Watches, with new series train, so thoroughly adjusted as to be unaffected by any change of temperature, exercise or position in the pocket; Astronomical Clocks, Transit Instruments, Standard and Self-Registering Thermometers, Barometers, &c. 1 13c0w\*

## THE UNDERSIGNED, WHO HAS A STORE

for the sale of machinery and a machine shop in the best part of London, is prepared to undertake agencies for the sale (by wholesale or retail) of novel American Agricultural, Domestic, and other machines and apparatus, and to let room and steam power to proprietors of patent machinery who wish to set up machines in London to show them in action previous to disposing of their patent rights in Europe. Business transacted in the French and German languages. Reference—L. P. FOWLER, Esq., New York Rubber Co., No. 45 Liberty-street, New York. WELBURN WILLIAMSON, No. 133 High Holborn, London England. 2 7\*

## WOODWORTH'S PATENT PLANING MA-

CHINES, of ever description and kind, at reduced prices, very low for cash, at the old stand, No. 57 Pearl-street, Brooklyn, N. Y. Send for a Circular of styles and prices. Address  
J. H. LESTER, Brooklyn, N. Y.

I am also manufacturing and selling as good Shuttle Sewing Machines, under legal rights, as was ever offered to the public, and for less money. For samples of Sewing and Circular of Prices, address  
J. H. LESTER, No. 483 Broadway, New York.

## PAGE'S LIME KILN (PATENTED 1854-57-58)

Will burn 100 lbs. lime with 2½ cords of wood or 1½ tons of coal in 24 hours. Coal not mixed with stone. It will burn all lime rock, marl or shell. Rights for sale by C. D. PAGE, Paten ee, Rochester, N. Y. 2 10t\*

## GRINDSTONES FOR MACHINISTS AND MAN-

UFACTURERS, of every size and grit, for wet or dry grinding. 6 5t\* J. E. MITCHELL, No. 310 York-avenue, Philadelphia.

## C. L. GODDARD, AGENT, No. 3 BOWLING

Green, New York. Only Manufacturer of the Steel Ring and Solid Packing, Burring Machines and Feed Rolls for Wood Cards, &c. 7 4t\*

## SUGAR-MAKING IMPLEMENTS.—PARTIES

intending to make, or desirous of making, Cane Mills or Sugar Apparatus of any kind, can get Rights to use Hedges' Improvements, with valuable information in reference to patterns, different modes of construction in order to make the work profitable at the established prices, and at the same time to secure to purchasers the very best Machinery, &c., together with an advertisement in our "Treatise on Sugar Cane," which will at once secure to them a share of our custom. All for a great deal less than experience, without such hints as we can give, will cost them. Hedges' Mills are very superior. Territory and Shop Rights for Cook's Evaporator for sale.  
HEDGES, FREE & CO., Cincinnati, Ohio. 6 4\*

## THE GREATEST POWER KNOWN FOR THE

Cost and Weight of Instrument.—Heavy Presses, adapted to all purposes, of any capacity; the power applied up, down, or horizontal. Hand Presses, light and heavy; Lifting Jacks, all sizes; one of two pounds weight with a two-inch lever warranted to lift one ton; also, Punches for Boiler-makers, on an entirely new principle. Address  
DAVID L. MILLEN, Madison, Morris Co., N. J. 6 6t\*

## CROSSETT'S PATENT STAVE CUTTER.—PAT-

ented July 1, 1844; re-issued March 2, 1853; renewed and extended June 26, 1858.—The above mentioned machine is warranted to cut more and better staves than any other machine in the United States, and is the most simple, cheap and durable. I hereby caution all persons against using and vending said machine (the main features of which consist in the stationary knife and vibrator bed-piece) without the legal right to do so. Offenders will be dealt with according to law. All persons wishing an interest in the extended term of said patent can obtain it by addressing the undersigned at Joliet, Ill. 5 10 GEO. I. CROSSETT, Assignee.

## THE AUBIN VILLAGE GAS WORKS WERE

erected last year by gas companies in several States and in Canada. The success attending these works has already led to the erection of one city and one village work this season, and secured three village works for immediate erection, and so nearly secured five more that they may be relied on before August next. For reference apply to the Aubin Company, No. 44 State-street, Albany, N. Y. 1 13\*

## CALIFORNIA AGENCY FOR PATENTS.—

WETHERED & TIFFANY, San Francisco, will attend to the sale of patent rights for the Pacific coast. References.—Messrs. Tiffany & Co., New York; Wethered, Brothers, Baltimore; George W. Bond & Co., Boston. 4 13

## D. DE FORREST DOUGLASS, SPRINGFIELD,

Mass., Inventor and Manufacturer of the New Artificial Leg. 3 5\*

## MESSEURS LES INVENTEURS—AVIS IM-

portant.—Les inventeurs non familiers avec la langue Anglaise, et qui ne peuvent nous communiquer leurs inventions en Français, peuvent nous adresser dans leur langue natale. Envoyez nous un dessin et une description concise pour notre examen. Toutes communications seront reçues en confiance.  
MUNN & CO., Scientific American Office, No. 37 Park-row, New York.

## OIL! OIL! OIL!—FOR RAILROADS, STEAM-

ers, and for Machinery and Burning. Pease's Improved Machinery and Burning Oil will save fifty per cent., and will not gum. This Oil possesses qualities vitally essential for lubricating and burning, and found in no other oil. It is offered to the public upon the most reliable, thorough and practical test. Our most skillful engineers and machinists pronounce it superior to and cheaper than any other, and the only oil that is in all cases reliable and will not gum. The SCIENTIFIC AMERICAN, after several tests, pronounces it "superior to any other they have ever used for machinery." For sale only by the Inventor and Manufacturer,  
F. S. PEASE,  
No. 61 Main-street, Buffalo, N. Y.

N. B.—Reliable orders filled for any part of the United States and Europe. 1 13

## STEAM ENGINES, STEAM BOILERS, STEAM

Pumps, Saw and Grist Mills, Marble Mills, Rice Mills, Quartz Mills for gold quartz, Sugar Mills, Water Wheels, Shafting and Pulleys. The largest assortment of the above in the country kept constantly on hand by  
WM. BURDON,  
No. 102 Front-street, Brooklyn, N. Y. 1 13

## BLANCHARD'S INVENTION FOR GENERAT-

ING STEAM.—This improvement can be connected with boilers of every class and description at a very small expense, and with this improvement their power will be more than doubled with the same amount of fuel, as has been clearly demonstrated. It will also produce the same equally great results, and is applicable in all cases where steam is required for heating, boiling, dyeing and manufacturing purposes generally; and it will produce any desired temperature of steam without a corresponding pressure. Address  
5 30\* F. B. BLANCHARD, No. 1 Spruce-st., New York.

## MACHINE BELTING, STEAM PACKING, EN-

GINE HOSE.—The superiority of these articles, manufactured of vulcanized rubber, is established. Every belt will be warranted superior to leather, at one-third less price. The Steam Packing is made in every variety, and warranted to stand 300 degs. of heat. The Hose never needs oiling, and is warranted to stand any required pressure; together with all varieties of rubber adapted to mechanical purposes. Directions, prices, &c., can be obtained by mail or otherwise at our warehouse. NEW YORK BELTING AND PACKING COMPANY. JOHN H. CHEEVER, Treasurer, No. 37 and 38 Park-row, New York. 1 13

## ALCOTT'S CONCENTRIC LATHES.—FOR

Broom, Hoe and Rake Handles, Chair Rounds, &c.—price \$25 ~and all other kinds of wood-working machinery, for sale by  
1 Unitf S. C. HILLS, No. 12 Platt-street New York.

## PORTABLE COAL GAS APPARATUS.—IT IS A

Fixed Fact!—The Gas Generating Co. is a great success, and their apparatus works beyond their most sanguine expectations. It is to be seen in operation at the St. Denis Hotel, 801 Broadway, German Clubhouse, 106 Fourth-avenue, and at the office of the Company No. 512 Broadway, opposite the St. Nicholas Hotel. Judge for yourselves, and recollect. HENDRICKX BROTHERS, Patentees. 1 1t

## WOODWORTH PLANERS—IRON FRAMES TO

plane 18 to 24 inches wide, at \$90 to \$110. For sale by S. C. HILLS, No. 12 Platt-street, New York. 1 1t

## HOYT BROTHERS, MANUFACTURERS OF

Patent-Stretched, Patent-Riveted, Patent-Jointed, Oak-Leather BELTING. Store, Nos. 23 and 30 Spruce-street; Manufacturing, Nos. 210, 212, 214 and 216 Eldridge-street, New York. A "Treatise on Machinery Belting" is furnished on application, by mail or otherwise, gratis. 1 12\*

## LARD OIL MANUFACTURERS.—MESSRS. WM.

SKENE & CO., manufacture purified Lard Oil of the best quality, for machinery or burning, in Bullet-street, four doors below Main, Louisville, Ky. 1 1t

## CARY'S CELEBRATED DIRECT-ACTING SELF-

Adjusting Rotary Force Pump, unequalled in the world for the purpose of raising and forcing water, or any other fluid. Manufactured and sold by CARY & BRAINARD, Brookport, N. Y. Also for sale by J. C. CARY, No. 240 Broadway, New York. 1 13

## FELT FOR STEAM BOILERS, PIPES, SHIP

Sheathing, Marble Polishers, Jewelers and Calico Printers' use, manufactured by JOHN H. BAGON, Winchester, Mass. 1 15\*

## BOILER FLUES FROM 1 1/4 INCH TO 7 INCH-

es outside diameter, cut to any length desired, promptly furnished by  
JAMES O. MORSE & CO.,  
No. 76 John-street, New York.

## GUILD &amp; GARRISON'S STEAM PUMPS FOR

all kinds of independent Steam Pumping, for sale at 53 and 57 First-street, Williamsburgh, L. I., and 74 Beekman-street, New York. 1 13 GUILD, GARRISON & CO.

## MARINE RAILWAYS.—THE SUBSCRIBER,

Marine and Naval Architect, is prepared to build Marine Railways and Dry Docks, and to furnish Steam and Horse-power Engines, Chains, Castings, &c., on short notice and on reasonable terms. Satisfactory reference given. Address  
H. I. CRANDALL,  
New Bedford, Mass. 1 9\*

## WROUGHT IRON PIPE, FROM ONE-EIGHTH

of an inch to six inches bore; Galvanized Iron Pipe, (a substitute for lead,) Steam Whistles, Stop Valves and Cocks, and a great variety of Fittings and Fixtures for Steam, Gas, and Water, sold at wholesale and retail. Store and Manufacturing, No. 76 John-street, and Nos. 29, 31 and 33 Platt-street, New York. 7tf JAMES O. MORSE & CO.

## 1,000 AGENTS WANTED.—FOR PARTICU-

lars send a stamp. C. P. WHITTEN, Lowell, Mass. 1 10\*

## 5,000 AGENTS WANTED.—TO SELL FOUR

New Inventions. Agents have made over \$25,000 on one—better than all other similar agencies. Send four stamps and get 80 pages particulars, gratis. EPHRAIM BROWN, Lowell, Mass. 1 10\*

## RIVETS—EVERY DESCRIPTION OF RIVETS:

Boiler, Tank, Safe, Belt, Hose, Shoe, and Timman's, black and tinued, constantly on hand. Socket bolts of any size furnished on short notice. TABER & GRINNELL, New Bedford, Mass. 1 9\*

## TO INVENTORS AND PATENTEEES.—A. B. ELY,

Counselor-at-Law, Traveler Building, Boston, Mass., will give his personal attention and experience of fifteen years to consultations and trials in all matters relating to the law of patents, interferences, infringements, &c. 1 9\*

## Zur Beachtung für Erfinder.

Erfinder, welche nicht mit der englischen Sprache bekannt sind, können ihre Mittheilungen in der deutschen Sprache machen. Etzigen von Erfindungen mit kurzen, deutlich geführten Beschreibungen beliebe man zu beschreiben an  
Munn & Co.,  
37 Park Row, New-York.

Auf der Office wird deutsch gesprochen.

IMPROVED SKATE.

Although this is not exactly the weather in which the skate is in general demand, and notwithstanding that we hope for many pleasant sunny days before Winter's icy grasp, yet it is well to be prepared for the season beforehand in order that dealers may know what the fashion will be, next winter, in skates, and should the thermometer even be at 95° or 100°, perhaps a picture of a skate may induce a sense of gratifying coolness on the persons of all our readers. Our illustration shows the improved skate which is the invention of J. H. Coe, and W. B. Sniffen, of Stratford, Conn., and who obtained a patent

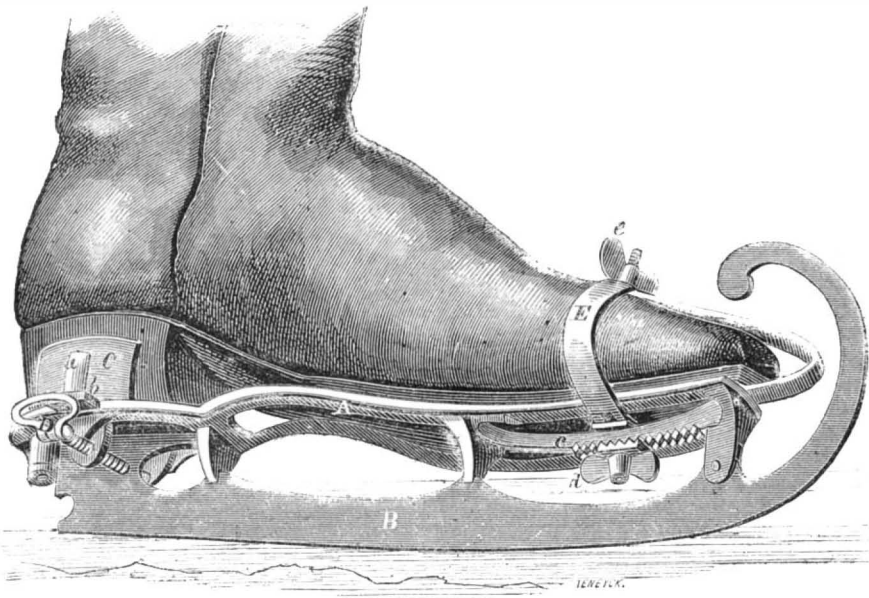

COE & SNIFFEN'S IMPROVED SKATE.

May 31, 1859. The skeleton base or foot-plate, A, is secured to the runner, B, in the most approved manner, and the front portion is perforated with a slot, the under edges, c, of which are serrated. A screw passing through this slot has slotted bands, E, connected with it, and which can be secured by a nut, d, and a small serrated piece between the nut d, and c, which fits into the serrations of c, and so prevents any forward or backward movements of E, when once fixed. A small nut, e, fastens the bands on the top. The use of these is to admit of toes of different widths, as they expand and can be contracted, and the longitudinal slot admits of a foot of any length being placed in the skate so that the same skate will fit feet of very different sizes.

On the heel, small plates, b, are capable of sliding, and the inside of these plates are turned down and are provided with threaded holes through which two screws, one a left and the other a right-handed screw, can pass; these screws being cut on the same piece of metal and operating simultaneously so as to throw both the plates, b, out equally or draw them in together, when turned by the handle D. From the exterior part of these plates a pin rises vertically on which clamps, C, having bearings, a, are allowed to move to adjust themselves to any shaped heel. These clamps are roughened on their inner surfaces, so that they bite and retain their hold when once clamped to the heel, without slipping. Separate clamping screws have been used before on the heels of skates, but their shafts were generally separate, rendering it difficult to adjust the clamps so as to bring the heel of the foot to the exact center of the skate, and also rendering it inconvenient to attach to the skate, owing to the fact that two screws, one upon the inside and one upon the outside, must be employed. Another plan is to have one clamp at the back of the heel, but this is objectionable because it does not give that lateral support to the foot so necessary in skating. The method of putting on the subject of this description is to loosen all the screws and placing the toe of the foot in the toe-piece-H, push it along until the proper length is obtained, then screw up the bottom screw and fasten that, and then press the bands round the foot until they fit tightly, and screw up the top nut, e, then draw up the clamps C, by their screws by the handle D, and when tight on the heel the handle D, can be folded under the heel where it

is out of the way of all obstructions, and not likely to inconvenience the skater. Any further information concerning this excellent invention will be given by the inventors upon being addressed as above.

CAMP'S BOILER FOR DOMESTIC PURPOSES.

This boiler, which is the invention of O. S. Camp, of Fairfield, Iowa, is fully represented by our engravings, Fig. 1 being a perspective view and Fig. 2 a section through it. The boiler is made with double sides or walls, A and B, one within and equidistant from the other; the bottom, C as well as the cover, D, is common

outer side which will not convey off its heat as rapidly as the air would do, when used without the outer wall. It is thus a great saver of heat as it loses little or none by conduction through the metal, there being a non-conducting medium between the inner and the outer wall. D is the cover, common to both boilers, the latter being provided with two concentric flanges, c and d, which fit against their respective sides, A and B, when the boiler is covered. h, represents two hinged clamps for the purpose of holding down the cover, D, and E represents the handles of the boiler. The entire is made of the metal known as galvanized iron, as it is more economical, durable and also less affected by alkali, acid, or by fire, than tin or copper.

In using this boiler the articles to be boiled, together with the requisite amount of water, are put into the inner boiler, B, the space between the outer and inner boiler being an air space, or partially or entirely filled with water; the water in the inner boiler is heated by the common process of boiling while the air or water in the outer space is heated by steam arising from the boiling water in the inner boiler, which passes through the holes a, and down the flue, b, and through e, into the water of the outer boiler. The inner boiler is thus surrounded by an outer boiler of the same temperature, which is a non-conductor of heat and prevents the inner boiler from cooling by conduction through its wall, and thus said boiler if once heated, will require but a small quantity of fuel to keep it at the same temperature; the cover D, must be fitted well to the inner boiler to prevent the easy escape of the steam, and should the pressure of the steam become too high it will escape through the pipe F, which opens inwards into the outer boiler. Thus it will be seen that there will be economy in fuel in using this double boiler as compared with a boiler of the common construction, and a further saving will be effected by making the same of galvanized iron as above described, as it is cheaper and more durable than the other sheet metals used for this purpose.

It was patented June 21st, 1859, and the inventor will be happy to give any further information upon being addressed as above.

to both. The space between the two boilers may be dead air space or be partially filled with water or steam for a purpose to be hereafter described. The inner boiler B, is furnished near to its upper edge with openings, a, a, from which the closed spaces, b, lead down in the space between the two boilers, so that if the space between the

Fig. 1

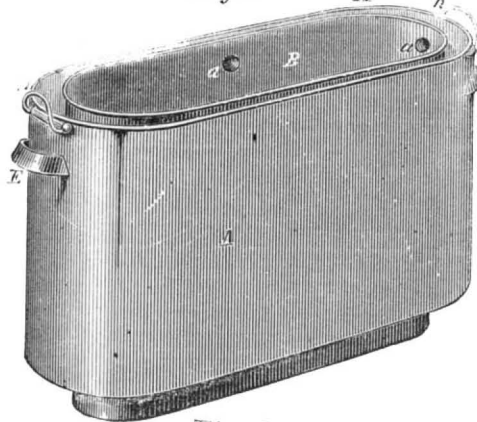
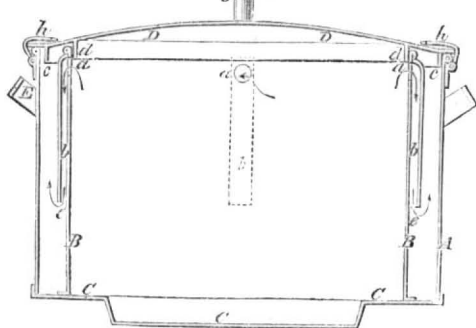

Fig. 2



double walls of the boiler be used as air space, and steam be passing through it, the steam shall enter low down, and then rise and pass through said space, or if the space be filled with water, so that the steam shall enter low down and thus more uniformly heat it up, as it comes in contact with a greater body of water. In either case the inner wall of the boiler has a heated medium on its

There are on earth 1,000,000,000 of inhabitants. Of these 33,333,333 die every year; 7,780 every hour, and 60 every minute—or one in every second. But there are always more births than deaths, and so population increases.

MECHANICS, INVENTORS, MILLWRIGHTS, AND MANUFACTURERS.

The SCIENTIFIC AMERICAN is a paper peculiarly adapted to all persons engaged in these pursuits, while to the Farmer, Housekeeper, and Man-of-Science, it will be found of equal interest and use.

The SCIENTIFIC AMERICAN has been published FOURTEEN YEARS, and has the largest circulation of any journal of its class in the world. It is indispensable to the Inventor and Patentee: each number containing a complete official list of the claims of all the patents issued each week at the United States Patent Office, besides elaborate notices of the most important inventions, many of which are accompanied with engravings executed in the highest degree of perfection.

To the Mechanic and Manufacturer the SCIENTIFIC AMERICAN is important, as every number treats of matters pertaining to their business, and as often as may be deemed necessary a column or two on the metal and lumber markets will be given; thus comprising, in a useful, practical, scientific paper, a Price Current which can be relied upon.

The SCIENTIFIC AMERICAN is published weekly, in a form suitable for binding, each number containing sixteen pages of letter-press, with numerous illustrations, making a yearly volume of 832 pages of useful matter not contained in any other paper.

Terms.

Two volumes will be issued each year; but there will be no CHANGE IN THE TERMS OF SUBSCRIPTION, as the two yearly volumes together will be Two Dollars a Year, or One Dollar for Six Months.

Club Rates.

Five Copies, for Six Months.....	\$4
Ten Copies, for Six Months.....	\$8
Ten Copies, for Twelve Months.....	\$15
Fifteen Copies, for Twelve Months.....	\$22
Twenty Copies, for Twelve Months.....	\$28

Southern, Western, and Canadian money or Post-office stamps taken a par for subscriptions. Canadian subscribers will please to remit twenty-six cents extra on each year's subscription to pre-pay postage.

For all clubs of Twenty and over, the yearly subscription is only \$1 40. Names can be sent in at different times and from different Post-offices. Specimen copies will be sent gratis to any part of the country.

When persons order the SCIENTIFIC AMERICAN they should be careful to give the name of the Post-office, County, and State to which they wish the paper sent. And when they change their residence, and wish their paper changed accordingly, they should state the name of the Post-office where they have been receiving it, and that where they wish it sent in future.

MUNN & CO.,  
Publishers, No. 37 Park-row, New York.