

THE
Scientific American,

PUBLISHED WEEKLY

At 123 Fulton Street, N. Y. (Sun Buildings.)

BY MUNN & COMPANY.

O. D. MUNN, S. H. WALKER, A. E. BEACH.

Agents.

Federhen & Co., Boston. Dexter & Bro., New York
A. Winch, Philadelphia. B. E. Fuller, Halifax, N. S.
A. G. Courtney, Charleston. S. W. Pease, Cincinnati, O.
Avery, Bellford & Co., London. M. M. Gardissal & Co., Paris

Responsible Agents may also be found in all the principal cities and towns in the United States.

Single copies of the paper are on sale at all the periodical stores in this city, Brooklyn, and Jersey City.

TERMS.—\$2 a year.—\$1 in advance and the remainder in six months.

Improvement in Fire Safes.

The annexed engravings represent the fire-proof metallic safe for which a patent was granted to Holmes & Butler, of the firm of Messrs. Holmes, Valentine & Butler, Nos. 90 and 92 Maiden Lane, this city, (N. Y.,) on the 28th of March last.

Fig. 1 is a perspective view of one of their safes, showing its interior, with the upper corner of the door, and a top corner broken, to show the lining and the inside of the thick double casing. Fig. 2 is a vertical section of a corner of the casing of the safe, and fig. 3 is plan view of the angle iron strapping, A, which binds the edges of the safe and renders it of great strength to prevent breakage, even if the safe were precipitated from a high upper floor into the cellar of a building, during a conflagration. Similar letters on all the figures refer to like parts.

D represents the outside and inside strong iron castings or walls of the safe—the door, in this respect, being made like the other parts of it. B is a flange on the door which slips into a recess in the walls of the safe; there are also small projecting pieces in the top and bottom of the door which fit into recesses in the walls of the safe when the door is shut, so as to render all the parts nearly as snug and firm as if the whole were one casting. A is the angle wrought-iron strapping piece of the edges of the safe; it is shown in fig. 3 as the binding of one corner, E, of the safe. Other safes, without such angle iron strapping, are liable to burst to pieces on falling from upper floors during fires, thus rendering nugatory all their fire-proof qualities. The space between the outer and inner casing or walls of the safe is filled with an incombustible substance which prevents the casing, and especially the interior from becoming highly heated when exposed to an intense fire, thus preserving books, valuable papers, &c., contained in it, from being burned and injured. The best fire-proof substance or substances for safe-filling is a desideratum, because this is the very thing on which their chief value depends. The older safes made some years since, were lined with incombustible anhydrous substances, such as fire-brick, pumice stone, &c. They were almost worthless, because when exposed for a long time to a fire they became heated throughout, and everything within them was burned. An improvement in such filling was the substitution of a hydrous substance like gypsum. An improvement on the use of gypsum simply was made, by the use of alum as part of a compound with clay and other incombustible substances. Common alum contains 24 H. O. water while gypsum contains only 2 H. O. Safes filled with alum or gypsum compounds, when exposed to a high heat, evaporate some of their water of crystallization and convert it into vapor, which contains a great deal of latent heat, and but a low specific heat, which tends to preserve the casing from becoming highly heated, even when exposed to an intense fire. The defect connected with this particular filling is stated to have been a liberation of some of the sulphuric acid of the alum and the gypsum with the vapor, which was liable to find its

PATENT PORTABLE FIRE-PROOF SAFES.

Fig. 1

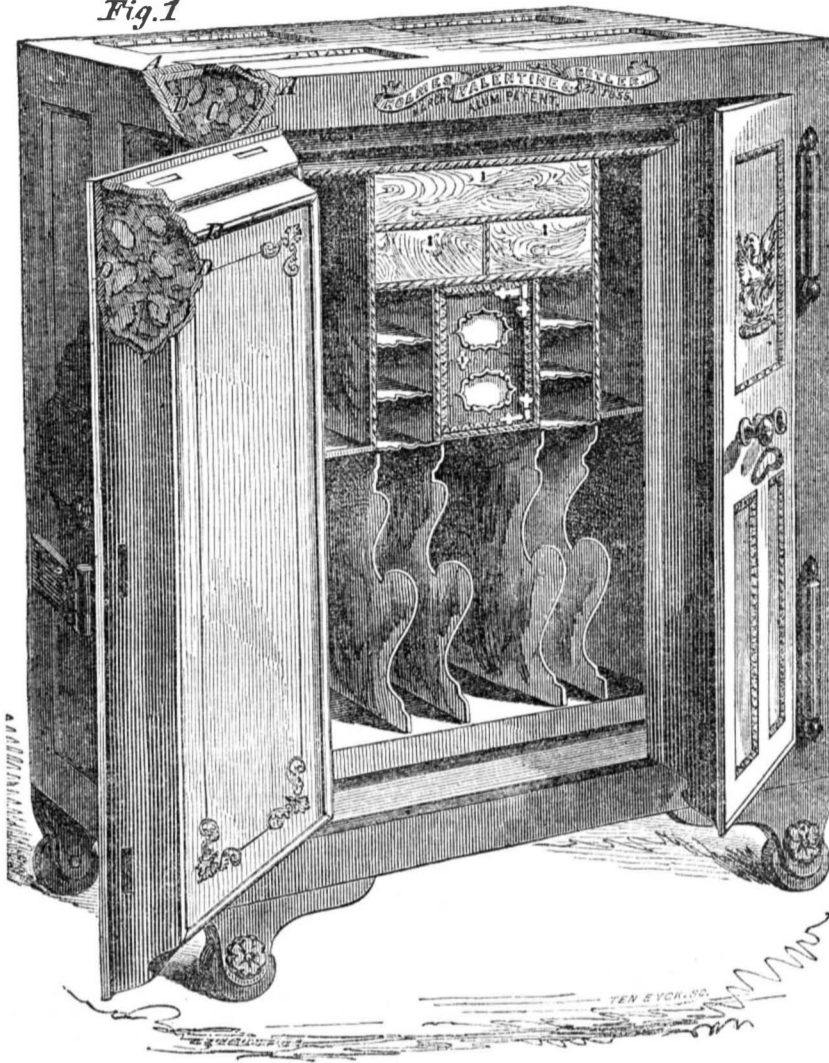

way through the expanded seams of the casing among the papers, acting chemically on the writing, obliterating it more or less, and also injuring fine articles of jewelry, &c. Another defect was, that when the water of the filling was thus partly expelled, in the state of vapor, the lining, especially the sulphate of alumina, contracted its bulk, leaving a free space or spaces between the under and upper casings of the top and sides, thus allowing the fire to act powerfully on the outer casing, and at last transmit the intense heat through the mass.—The aluminous filling, containing so much water, was also liable to become fluid, sink down into the lowest part of the safe, and ooze through the seams, finding its way outward, also into the interior, destroying the contents, with which it came in contact, and leaving the upper part of the safe empty and exposed to the action of the fire.

To remedy these defects in the filling of safes, was the object of the patentees of this safe, and it was for this improvement the patent was granted. They employ a compound of clay, or any other earthy incombustible substance, such as soapstone, pumice stone, &c., and the alum of commerce and an alkali. The latter substance—the alkali—is used to neutralize the free acid that may be generated when the safe is exposed to fire, and thus to prevent any injury to the contents of the safe from such a cause. In order to prevent the filling of the safe settling down when it shrinks or becomes fluid—whereby the outer casing would be exposed to the dangerous action of the fire—they pack their filling interspersing it with irregular-shaped pieces of porous unshrinking brick, as shown, the pieces touching one another at points, and also resting against the sides of the plates. This method of filling the fire-proof space converts it into a series of cells, preventing the incombustible filling from settling and from running down, keeps it

close to the casing and forms a cellular fire-proof tissue which most effectually resists the action of the heat. All the interior seams are also lined with strips of thick felt boiled in a strong solution of alum, so as to prevent the outlet of vapor or fluid matter, and the utmost care is exercised to render the safe as perfectly fire-proof as possible.

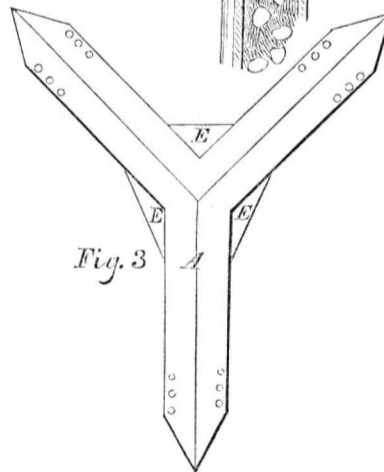
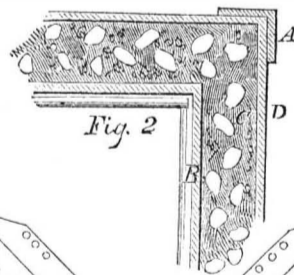

The use of safes has become wonderfully extended during the past few years, and many large companies are now engaged in their manufacture in nearly all the principal cities of the Union. Their value is now much better appreciated, still, they are far from being as extensively used as they should be.—Every warehouse, store, and gentleman's

dwelling should be provided with one.—Various sizes of them are made—large ones for banks, stores, offices, &c., and small ones for private dwellings. There are few persons who have not valuable papers and other things which they desire to have protected from fire and burglars, and these safes are the very means of doing this.

The inferior construction of safes a few years ago, and the huge keys required for their locks, were serious obstacles to their general use. The above illustrated safe has a fire and burglar-proof lock on it, with a key so neat and small that it might be carried in a lady's thimble, and still it answers just as good a purpose as one of the old keys, which was large enough to fell an ox. These safes are tastefully executed, and resemble an ornamental piece of furniture, and being placed on wheels can easily be moved.

Although pieces of porous brick are employed, as described, in the safe, by Messrs. Holmes, Valentine & Butler, still, these are not positively necessary, as they can pack their safes with their fire-proof composition in such a manner as to prevent any contraction, or falling down of the filling, under the most severe tests. Common safes, owing to the kind of filling used in them, are liable to become damp, and for this reason they are not suitable, especially for containing fine jewelry, &c., as dampness injures such articles. The filling used for these safes generates no dampness, and they are warranted to keep perfectly dry in every case, which is a very important feature in their construction. Those who have tested various kinds of safes, know the value of having a perfectly dry one.

Messrs. Holmes, Valentine, & Butler constructed the safe which stood 24 hours roasting in the furnace at the great trial which took place in the Crystal Palace in Dec. 1853—the contents of the other safe being wholly destroyed, while all the books in theirs (except the backs of two, which were slightly scorched) were taken out in good condition. The patentees conduct an extensive business, and their safes have obtained a wide-spread celebrity.

More information may be obtained respecting them by letter (or otherwise) addressed to the manufacturing warehouse, Nos. 90 and 92 Maiden Lane, and W. G. Holmes is now in Chicago, Ill., where the company has an office.

Using the Power of Distant Waterfalls.

MESSRS. EDITORS—I was gratified to see you notice the suggestion of a correspondent in regard to the storming of Sevastopol, as possibly people may be benefitted by suggestions, and in view of this I wish to say that the time is not far distant when the power that can and will be obtained from the falls of Niagara will be transmitted to Black Rock and Buffalo by coupling shafts, giving power enough to accommodate the wants of all. The power from the falls below Rochester will be used in the same manner. I had rather have stock in either of such enterprises than many of the railroads under contemplation. S. AVERY.

Weedsport, N. Y., Nov. 2, 1855.

[The last time we were at Niagara, (1846,) we came to the conclusion that there was a vast mechanical power running to waste. We think the project of our correspondent will not soon be carried out, still the thing is not impossible. But large manufacturing villages near the falls, for the purpose of employing the water power, by short lines of shafting, would be a far better plan of using that power than long shafting running to Black Rock or Buffalo.

Caution to Mechanics.

A merchant in Mobile, Ala., has brought suit against a shoemaker, for failing to comply with a promise to have a pair of boots made at a specified time.



[Reported Officially for the Scientific American.]

LIST OF PATENT CLAIMS

Issued from the United States Patent Office
FOR THE WEEK ENDING NOV. 6, 1855.

MARBLE SAWING MACHINES—R. G. Pine, of Newark, N. J. : I claim the frame, B, connected by jointed rods, f, to rods d, working in sockets, b, which are fitted loosely on rods, a, when the above parts are all constructed and arranged in the manner and for the purpose set forth.

[The nature of this improvement consists in attaching the saws to rods which operate through adjustable guide pieces. The latter are movable by means of set screws, so that the angle at which the saws cut may be regulated at pleasure and very quickly.]

This invention is the type of a large number of others, all intended for the same purpose. It will apparently work in practice, and cut two tapering sides of a block at once. How good it will operate, however, or whether better than some of the other machines, remains to be ascertained by actual trial.

A very large number of applications for patents on marble saws have been made, and many of them have come up for examination at the Patent Office. They conflict with each other pretty generally, as we predicted would be the case. There are few of the applications but are adjudged by the Commissioner of Patents to interfere with others, and from fifteen to twenty different cases are frequently given in reference. Amid such a scramble for the prize it is doubtful whether any one gets it. Like the leg of mutton among the dogs, scarce a mouthful will be left for any of them. Great business, this marble sawing!]

CHAIN LOCKER PIPES—Charles Perley, of New York City : I claim the locking piece, f, constructed substantially as specified, and applied to the chain locker pipe, in the manner and for the purposes set forth; and in combination with said locking piece, f, and flanges, c and d, I claim the cover, g, for the purposes and as specified.

STEAM BOILERS—H. N. Pettengill, of Rockford, Ill. : I do not claim any one of the several parts described; but I claim the arrangement of the flues, C and E, the water chambers, H H, and projections, I and I', with the feed water pipes, J and J', combined in the manner and for the purpose set forth.

ROTARY STEAM ENGINES—Elias Matteson, of Dayton, N. Y., W. M. Parris, of Dorset, Vt., and Hervey Parris of Pawlet, Vt. : We do not wish to confine ourselves to any particular number of steam chambers, nor to any particular number of pistons in a steam chamber; nor do we wish to confine ourselves to slotted abutments, for we do not consider it will alter the nature of our invention, whether the pistons pass the abutments by slots in the same, or by slots in the steam wheel.

But we claim, first, the cut-off crank, Z, and anti-friction rollers, X, in combination with the ellipse, D, and balance beam, N, when so constructed as to alternately open and close the cut-off valves, substantially as described, and for the purpose of effecting an adjustable cut-off.

Second, we claim the air spring to steam wheels, when so constructed as to have direct influence on the steam piston, and by its reciprocal action, to maintain a steady, even motion of the engine, when in unison with the cut-off, in the manner and for the purpose substantially as described.

MACHINES FOR SAWING MARBLE—Henry Burt, of Newark, N. J. : I am aware that different adjustable apparatus have been used for sawing wood, and that horizontal saw frames have been used for sawing stone into square blocks, parallelograms, thin slabs, &c. Also connections of various kinds have been used. I do not, therefore, claim the above devices separately.

But I claim the combination of the saw frame, B B', pivoted, swinging, adjustable guide frames, A A', and connection rods, d d', arranged and operated in the manner and for the purpose set forth.

HEATING AIR FOR BLAST FURNACES—Thos. W. Bakewell, of Cincinnati, O. : I do not claim the introduction to furnaces of heated air or steam by itself, either separately or combined.

But I claim the heating of air to supply furnaces by bringing the escape steam of an engine into direct and intimate contact therewith in a suitable vessel, separate from the furnace and previously to its admission thereto, substantially in the manner set forth.

[By this improvement the furnace fire is supplied with heated instead of cold air, the object being to save fuel. The invention consists in heating the air by bringing it in direct contact and mixing it with, the escape steam from an engine, in a vessel common to both. The air is driven into the said vessel by a fan, and the resulting water of condensation is carried off to the force pump by a pipe provided for the purpose. The inventor claims to effect a considerable saving in fuel. There is no difficulty about the introduction and use of his method; nor is the expense of its adaptation very much. It appears to be a useful invention.]

WHIFFLETREES—George C. Barney, of Brookline, Mass. : I claim making the whiffletree in two parts, in the manner essentially as described, and connecting them together and to the cross bar of the shafts by devices or means, substantially as specified, whereby results as explained may be attained.

BENCH PLANE IRON—I. Henry A. Bleckmann, of Ronsdorf, Prussia : I claim the placing of a piece or a plate of steel between plates of iron forming a plane iron for the purpose and in the manner above described.

LATH MACHINE—Andrew Blaikie & Walter Clark, of St. Clair, Mich. : We do not claim, separately, the feed rollers, for they are in common use.

But we claim the arrangement of the saw, D, separating plate, J, deflecting or guide plates, J, and feed rollers, E E', for the purpose specified.

[The lath stuff is fed up to the circular saw by means of feed rollers, in the usual manner. Behind the saw there is an upright stationary knife edge or wedge, which opens the kerf and causes the lath to fall off one side into a box, while the stuff falls off on the other side upon an inclined plane, down which it slides by its own gravity, back to the feet of the operator, ready to go through the machine again. This self-acting return movement of the stuff is a great convenience, and saves considerable labor. The improvement is a good one, and so simple that it will no doubt be extensively introduced.]

AUTOMATIC LUBRICATORS FOR RAILROAD AXLES—Michael Egan, of Ogdensburg, N. Y. : I do not claim, in general terms, feeding oil to the axle by intermittent motion of the feeder or feeders, produced by the revolution of the axle or otherwise. Neither do I claim the employment of a feeder, which, by either constant or intermittent motion, receives oil from a reservoir below and deposits it on the axle.

I claim the arm, B, placed under the bearing, and made to descend into the grease and rise to the journal at each revolution of the axle, by being connected to the eccentric, D, or its equivalent, substantially as set forth.

COMPOSITION FOR KINDLING FIRES—Bernard O'Reilly, of New York City : I claim the fire-lighting compound formed by the admixture of the several ingredients specified, in the manner, and in about the proportions set forth.

[This compound is intended for use in cities, and wherever a blaze is wanted for lighting fires in stoves, &c. Paper is very frequently used, at present, for the purpose. The mixture is made up of turpentine, powdered charcoal, gum olibanum and camphor, combined in certain proportions. It is kneaded into small lozenges, one of which is sufficient to light a fire, as it will burn for quite a little while, and produce an intense flame. This is a very excellent fire-lighting material.]

KNITTING MACHINES—Arasmus French, of Waterbury, Conn. : I claim the combination of the eye-pointed needle, D, with the hoop, a, when constructed, arranged, and made to operate substantially as described.

Second, I claim the method of opening and closing the clamps, d d', for holding the hoops, a, by the use of the cams or wedges on the circle, B, when worked by the same eccentric which works the needle when the whole is constructed and made to operate, substantially as described.

Third, I also claim the method of narrowing by giving a longitudinal motion to the arch bar, F, when constructed, arranged, and made to operate substantially as described.

WASHING MACHINES—Daniel Haldeman, of Morgantown, Va. : I claim the combination of the hinged arms, crank shaft, restraining hooks and rubbing board, for the purpose of holding and operating said rubbing board in its proper position whilst washing, and to enable the operator to raise it out of the water, to replace the clothes by simply throwing back the restraining hooks and drawing the shaft, still pivoted to the arms, towards the end of the machine, as set forth.

SELF-ACTING MULES—John Harris, of Lawrence, Mass. : I do not claim combining with mechanism for producing a regular backing-off movement of the carriage machinery, not only for giving a slow motion to it during the first part of its running-in movement, or while the "fuller" is descending on the yarn, a quicker movement afterwards, or while the carriage is running in, but finally a slower movement, decreasing to completion, of the extent of inward movement of the carriage.

But I claim the peculiar combination before described and applied to the endless chain, and for effecting such variable movement or running in of the carriage, the same consisting of the driving shaft, G, the clutch apparatus thereof, the barrel gear, I, the eccentric gear, M, and mechanism connecting the latter with the shaft, E, of the endless chain, the whole being arranged and applied, substantially as specified, to the mechanism for producing regular movement of the chain in a reverse direction.

BRICK MACHINES—Alex. H. Brown, of Washington, D. C. : I claim, first, the combination of the outside plungers with the skeleton wheel, inside plunger, and molds, when arranged and operated as set forth, and not otherwise.

Second, I claim discharging the bricks by means of the ratchet stock, K, vertical bars, P P, and inside plungers, E, when arranged and operated as described, and not otherwise.

Third, I claim the mode of regulating the amount of feed through the action of the quadrants upon the inside plungers, when arranged as described.

Fourth, I also claim regulating the movement of the skeleton wheel, C, fig. 1, upon the lower plunger when arranged as described.

ARRANGEMENT OF TWO BEAM ENGINES WITH PARALLEL SHAFTS—Thomas Doyle, of New York City : I claim the arrangement of two beam engines in line with their cylinders contiguous to each other, and the connection of the piston ends of the beams by an intermediate beam, C, substantially as, and for the purpose set forth.

[The walking-beam engine is doubtless well known to all our readers, for it is in common use on board of American steam vessels of every kind. If the reader will imagine three of these engines placed one after the other, in "Indian file," as the boys say, he will have an accurate idea of Mr. Doyle's improvement. The invention consists in connecting all the three engines together, in such a way that their movements are regulated, and the power properly equalized. The object is to drive two pairs of paddle wheels simultaneously. Two steam cylinders are employed; the central engine is connected at one of its beam ends to the piston of one of the cylinders, and at the other end to the other piston. The remaining engines connect respectively with the central engine from which they receive motion.]

LOCKS—D. W. G. Humphrey, of Gray, Me. : I claim the indicator, A, movable ward plate, B, and lever, E, arranged and operating in the manner set forth.

GAS HOLDERS—Stephen Hill & Wm. J. Wood, of Rochester, N. Y. : We claim the combination of the pipes, T T, with the diaphragm, d, within the gas holder, for the purpose of applying a suitable pressure to fill the gas holder or with gas, and to expel the gas therefrom.

SAW HORSE—Horace Lane, of Windsor, Vt. : I claim the use of the spur, I, to hold the wood or timber in its place on the saw horse while the sawyer is sawing the wood or timber into fire wood or into short pieces. Also the use of the roller, the ratchet wheel, the lever, the dog and spring, the cord, the pulley wheel, the slide, the arbor, and the groove and spiral spring, combined with the common saw horse, substantially as set forth and for the purposes stated.

I do not make any claim on the common saw horse, but for the improvements on the same as set forth.

SPLITTING LEATHER—Jeremiah A. Marden, of Newburyport, Mass., and Henry A. Butters, of Haverhill, Mass. : We claim combining with the feeding apparatus or mechanism, substantially as described, by which the leather may be restrained in its delivery, so as to effect the reduction of "cockles," as specified.

CUTTER HEAD FOR ROTARY PLANES—Wm. Nixon, of Adrian, Mich. : I claim the double bevel of the cutter, in combination with the bevel on that part of the stock or cylinder which is in front of the cutter, so that the stock may act as a cap-iron to the cutter, and to clear the shavings, as set forth.

CLOTHES CLAMPS—James Sadgebury, of Philadelphia, Pa. : I do not claim the mechanical principle involved in the operation of this clothes clamp, as it is well known; nor do I claim a clothes clamp, that is made to string upon the line, there being a hole made in the clamp through which the line is passed; nor do I claim a clamp, made to clasp the line by means of springs.

But I claim the grooved button, D, in connection with the grooved protuberances, A B, substantially as set forth.

DRILLING AND BORING MACHINES—Samuel M. Shryock, of Hopkinsville, Ky. : I claim supporting the rests, n, by rack, F, and pinion, p, of shaft, E, and combining the same with movable and fixed pulleys, G and H, as set forth, as that the rests may be moved upward with any required velocity, or be dropped from the drill, at the will of the operator, during the revolution of the boring shaft, as, and for the purposes specified.

ARRANGING AND FEEDING SCREW BLANES—Elliot Savage, of East Berlin, Conn. : I claim the combination of the reciprocating slider, the receiver or hopper, and the inclined conductor, the same being arranged and made to operate together, substantially as specified.

I also claim combining the spring presser with the slider and hopper, and so as to cause the slider to operate laterally, with respect to the screw blank, as explained.

SEWING MACHINES—Isaac M. Singer, of New York City : I claim the employment of two eye-pointed needles, carrying its appropriate thread, and the two working in unison, substantially as specified, in combination with a shuttle, or equivalent therefor, to effect the concatenation of the two sets of stitches substantially as specified, and for the purposes set forth.

SOFA LIVE BOATS—Peter Van Zile, S. M. Griffin, and J. W. S. Dey, of New York City : We do not claim, broadly, making a life preserver in such a manner that it may, when out of use for this special purpose, be applied to other useful purposes, either with or without change of modification.

But we claim the structure set forth, the same consisting of two buoyant parts, so constructed that, when separate they shall each form a settee or sofa, and when united, a life boat, as set forth.

SELF-FEEDING ATMOSPHERIC LUBRICATOR—John Sutton, of New York City : I claim an arrangement of means, constructed on or within the cap or cover, B, (of the reservoir containing the oil, or other lubricating material,) sufficiently distant from the oil to never be in contact with the same, by the adjusting of which the passage or passages leading from the reservoir to the atmosphere, may be entirely or partially opened or closed, at will, thus causing an increase or decrease of the feeding of the oil to the part receiving lubrication. When properly adjusted, the dome, C, may be firmly secured down, when nothing can interfere with the regulating part.

I do not confine myself to the use of the plug, D, and the substance in the space, E, as a hollow or other plug, or equivalents, may be used to produce the same effect; either of which may be used as the part, when placed, may permit, and without altering the principle or mode of feeding described.

DOOR SPRINGS—Amos Westcott, of Syracuse, N. Y. : I claim, in this class of door springs, adjusting the jointed levers substantially as set forth, and also adjusting the pulley, and for the purpose described.

HANGING WINDOW SASHES—J. W. Ross, of Zanesville, O. : I claim attaching the straps, C F, to the sashes B B', said straps passing in reverse direction around pulleys, b, E, on a shaft, B'', in the stile, a, of the casing, A, the pulley, E, being attached permanently to the shaft, B'', and the pulley, b, placed loosely upon it, and the pulleys, b E, being connected and disconnected when desired, as shown, the pulley, b, having a pulley, b', attached to it, to which pulley an elastic band, D, is attached, said band being also attached to the sash, B, the above parts being otherwise arranged, substantially as shown and for the purpose set forth.

[This is an improvement in the mode of hanging window sashes without weights, where one sash is made to counterbalance the other. The common method is to have simple pulleys in the upper part of the window frame, with connecting cords, so that when one sash goes up the other comes down. The present invention consists in having double pulleys, which may be connected or disconnected, at pleasure, by means of a clutch, so that when it is desirable, one sash may be raised or lowered independent of the other. The pulleys are placed on the sides of the frames, and the clutches are operated by a thumb button.]

MORTISING MACHINE—Loomis E. Payne & Orris Pier, of Stowe, Vt. : We claim a double semi-circular mortise bit or gouge, arranged so as to clear itself thoroughly in its action, and this in combination with the double eccentric plate, to regulate the motion to and fro of said mortise bit, the whole being combined and operating substantially as set forth.

CHIMNEY CAP—Jno. W. Davies, of Richmond, Va. : I do not claim the cone, or the other parts, separately considered.

But I claim the combination of the cap, E, and the cone, D, with the tubes, A, arranged substantially as described, and for the purposes specified.

RE-ISSUE.

HARVESTING MACHINES—Jonathan Haines, of Pekin, Ill. : I claim, in combination with a frame nearly balanced on its supporting wheels, and a tongue, hinged to said frame, a lever connected to one, and projecting towards the driver's stand or seat on the other, so that the driver, who is the sole conductor of the machine, may, from said stand or seat, raise or depress the cutters at pleasure, during the operation of the machine, for cutting the grain or grass at any suitable height above the ground, or for passing over any intervening obstacles, substantially as described.

I also claim, in combination with the operative parts of a harvesting machine a conveyor, which first carries the cut grain horizontally across the machine, and then elevates it, so as to discharge the grain into the bed of a wagon driven along side of the machine, when the conveyor or frame is connected to the bed by a flexible joint, in the manner and for the purpose described.

ADDITIONAL IMPROVEMENT.

VENTILATING AND WARMING HOUSES—Henry Rutan, of Coburg, Canada : I claim to have added to my original patent the foul air receptacle, added to, and connected with the system of ventilation patented to me Dec. 5th, 1848, said receptacle being connected with the vertical passages and ventilating chimneys, substantially in the manner set forth.

DESIGN.

COAL STOVES—Garretson Smith & Henry Brown, (assignors to Leibbrandt, McDowell, & Co.,) of Philadelphia, Pa.

[Our Foreign Correspondence.]

Interesting Particulars in regard to the Mammoth Steamship "Great Eastern."

LONDON, Nov. 1, 1855.

MESSRS. EDITORS—On my visit to the mammoth steamer now building at Blackwall, on the Thames, I was fortunate enough to procure from the engineers and others the following information. Much has been said, although little is known respecting her, especially in the United States.

The vessel is not yet named, though it is rumored she is to be called the *Great Eastern*. She is being built by J. K. Brunel, Esq., the well-known engineer for the Eastern Steam Navigation Company—who have a capital of six million of dollars; their vessels are all designed for the India and Australia trade, and will be four in number, the first being the *Great Eastern*. She will be the largest and most powerful steamship in the world, as will be seen by the following statement of her dimensions:—

Length, 680 feet; breadth, 83 feet; depth from deck to keel, 58 feet; number of decks, 4; length of saloons, 400 feet; height of saloon between decks, 15 feet; capacity, 27,000 tons; will carry 18,000 tons of coals and cargo. She is to have both screw and paddle engines, whose nominal horse power will be: screw, 1,600, paddles, 1,000. Total, 2,600 horse power. Cylinder of screw engine, 4 feet; diameter of cylinder, 84 inches; stroke, 4 feet; cylinders of paddle engines, 4 feet; diameter of paddle engine cylinders, 74 inches; length of stroke, 14 feet 6 inches. Each engine-room will be forty feet long. The screw propeller will be 23 feet in diameter. The paddle wheels have been fixed at sixty feet diameter. Draft of water, loaded, 8 feet; draft of water in ballast, 18 feet. She is to carry six hundred first class passengers and eighteen hundred second class. If used as a transport, she will carry

J. P. B.

an army of 10,000 men, with all their field equipments. Weight of iron used in construction 7,000 tons. She is to be built double, having an inner and outer shell of iron plates. The masts are five in number—ship rigged. The steering apparatus consists of two rudders, which, from their power, ought to bring her round. The after rudder is to be placed like an ordinary ship's rudder; the screw will work forward of this rudder; ahead of the screw is to be a second rudder, in form something like a common rudder. The engines will be larger than any hitherto made. They will be placed in different parts of the ship, entirely independent of each other. The vessel will have ten boilers and five smoke pipes. Every boiler can be cut off from its neighbor and used or not, as desired; they will be placed longitudinally along each side of the ship. Some idea of their generative power may be formed when I say that every boiler will have ten furnaces, thus giving to the whole no less than one hundred large fires. An experimental boiler was made previous to deciding upon the one to be adopted. The coal to be used will be anthracite. The vessel will have two paddle wheels in the usual manner, but the paddle engines are to be on the disconnecting principle, that they may be used jointly or separately, so that one or both of the paddle wheels may, if desired, be put in independent motion. Her deck is to be flush; and a promenade deck, twice the length of the famous *Great Britain*, will be available for her passengers. In her external appearance—drawing inference from the working model—I should think the *Great Eastern* would be a splendid ship. She is molded with very fine lines forward and aft, with an elliptical stern. Her speed should average fourteen miles an hour, while her great size ought at all times to prevent her from shipping water. One of the reasons for building her so large is to give her capacity enough for carrying coals for a continuous voyage of twenty-five thousand miles, thereby saving the expense of establishing coal depots, and the time lost by coaling in foreign ports. These items alone are estimated at 40 per cent. of the outlay for the vessel.

In case of accidents she will have many unusual chances. The floor of this ship is to be perfectly flat. The outer and inner plates will be joined to each other by longitudinal webs or girders formed of plates and angle iron. There will be seventeen of these webs on each side of the ship, thus joining the outer and inner skins by means of a number of water tight cells, of such extraordinary strength that they give a rigidity never before communicated to any vessel. Besides these small cells forming the wall, as it were, of the ship, she is being built in seventeen sections—the midship section being first built up to its full altitude, and the iron decks laid—the other sections, fore and aft, being successively built in like manner and jointed to the preceding section. It may, therefore, be said that the ship will consist of a great number of water-tight apartments between the outer and inner skins, and of thirty-two large square compartments in the body of the vessel, not merely nominal divisions, but complete, substantial, water-tight bulkheads, of sufficient strength to bear the pressure of being filled with water. In case of accidentally being broken in two, the separate portions would float, without damage to the cargo contained in the uninjured sections. The outer plates are of inch iron—the inner three-quarter inch iron securely bolted and riveted together. The first plate was laid in May last. A number of the sections are now built; the stern-post is erected, and the ribband or outline of the after-part of the ship is already put up. The work is rapidly progressing; at the present time over five hundred men are at work upon the ship in all departments. Should no unforeseen obstacles arise, she will be launched within a year. Owing to her great size she is being built broadside to the river. It is intended to launch her by means of two immense cradles, which will gradually lower her down to low water mark, whence, on the ensuing tide she will be floated off.

California will yet become a silk, as well as a gold-producing State. Dr. Behr, of San Francisco, has discovered a native silk worm of rare qualities, for spinning fine cocoons.

Scientific Notes.

THE CAUSE OF THE OPEN POLAR SEA—A correspondent of the *New York Times* presents the following theory of the open polar sea:—

"When the facts become more fully understood, I think that it will appear that this singular result will be found to proceed from very simple natural causes, namely, the centrifugal force and the internal heating power of the earth. The centrifugal force has a tendency to heap up the waters under the equator, thereby producing a continual surface current toward the South, and a consequent absence of water from the polar regions, which must be supplied, and is undoubtedly by a submarine current. The waters descend in the temperate regions of the earth, where they are much above the freezing point; their heat is retained, and probably increased at the vast depths in which they move, and when they emerge at and about the pole, they produce a warm and open sea, and a warm atmosphere about it. But in their flow to the South, the superabundant calorific of the water is continually being given off, until the waters are finally reduced to the freezing point, and ultimately become vast fields of ice."

[We conceive that the above is not a good explanation of the cause of the open polar sea. It is well known that there is a cold surface current in the Atlantic flowing to the tropics from the Northern Sea, but if the centrifugal force theory here set up were correct, there would be a surface current from the south and an under current from the north, which would prevent fields of ice forming in the Northern Ocean. An open arctic sea is not a new discovery; it is described in Lieut. Maury's work, and he believes that, like the Gulf Stream, it often changes its position somewhat. There is a warm under current flowing from the tropics to the Arctic ocean, and were it not for this, the northern seas would freeze to the very bottom, and what then would we do for herring, mackerel, cod, and other fine fish, whose natural feeding waters appear to be in the Arctic Ocean.

A STRATUM OF SALT UNDER NIAGARA FALLS—E. Merriam, of Brooklyn, who has examined the rocks underlying the limestone bed of the Niagara river, states that he found a saline stratum under them. This stratum is the foundation of the great limestone walls which form the great cataract of Niagara, a frail structure it is, and it is in this stratum that the Niagara has the whole of its bed below the Falls, and being soft, the water which falls over the Horse Shoe and over the American, North of Goat Island, has had no difficulty in sinking chasms of vast depth, into which the broken rock of the limestone walls which compose the cataract falls. This stratum extends over a large tract of country, watered by the great lakes, which seem to have a subterranean communication with the volcanoes of Hecla, in Iceland, and those of the southern part of the European continent, as the disturbance caused by the earthquake at Lisbon, in 1775, caused the agitation of the waters of Lake Ontario. He says that an immense volume of gas arises from the chasm into which Niagara plunges from the lofty precipices which form the Horse Shoe on the American fall, and might with proper apparatus be ignited—and when on fire would greatly exceed in beauty the flames of the gas ascending from the deep ravines of the salines of Kanawha, which give a column of flame of seventy feet in height. His conclusion, from all his observations is, that the great falls do not date beyond the universal deluge.

A PETRIFICATION, AND NATURAL DAGUERRETYPE ON STONE—The editor of the *Oquaca Spectator*, Illinois, it is stated, has two remarkable curiosities in his cabinet. One of them, he says, appears to be a petrified ham, so perfect in form that even the skin preserves its distinctness where the knife of the trimmer has rounded the edges. The other specimen is a stone containing a photographic impress of a beautiful landscape. It is about four inches long by two inches in width; the picture represents, in their true colors, a bluff or bank of yellow clay, the meandering line of a creek lined with willows and cotton woods, and a spring crowned with a large tree. This landscape is the correct representation of a view in Warren County, Ill. Mr. Patterson, the ed-

itor, attributes the picture to the action of electricity during a thunder storm, while the image had been reflected on the surface of the stone.

THE EFFECTS OF CANNONADING ON THE BAROMETER—M. Le Maout, the chemist, who has acquired some celebrity at St. Brieuc, his residence in France, for his observations of the barometer, as affected by a distant cannonade, states in the *Publicateur* of St. Brieuc, that he announced the cannonade and the assault of Sevastopol from the changes affected in the mercury. He adds, that it takes an hour and forty minutes to receive the impression of the guns of Sevastopol on barometers in France.

REAPING MACHINES IN ENGLAND—The report of the trial of Reaping Machines, which took place in England on the 29th of August last, before the Royal Agricultural Society, has recently been published. The Judges awarded two prizes, the first to Burgess & Key's improvement of McCormick's reaper; the second to Palmer's improvement of Forbush's reaper. Hussey's reaper, as improved by Wm. Dray & Co., of London, was highly commended, but did not have any prize awarded. This trial is stated to have been a severe and impartial one. One of the most remarkable circumstances about such trials is, that during the five years in which the English Royal Agricultural Society has offered premiums for the best machines, in each year a different machine has been pronounced the one superior to all others. In the first year McCormick's was classed first; in the second year Hussey's; in the third year Bells, manufactured by Crosskill; in the fourth year Hussey's, manufactured by Dray & Co.; in the fifth, the present year, McCormick's, manufactured by Burgess & Key. These yearly changes may probably be attributed mainly to new improvements introduced into machines which failed on previous trials.

PHLEGER'S COAL BURNING LOCOMOTIVE—The *North American Gazette*, (Phila.) states that an experiment has recently been tried on the West Chester Railroad, (Pa.) with a new coal burning locomotive constructed by L. Phleger, named *Anthracite*, which performed satisfactorily with half the quantity of coal usually consumed. No sparks nor smoke were emitted from the chimney, and the steam was maintained at 100 lbs. pressure on the inch without any trouble, during the whole trip. How this locomotive economizes, the *Gazette* does not tell.

American Inventions in France.

A correspondent of one of our daily papers gives utterance to the following interesting remarks:

"Some time ago a separate department was made in the Paris Exhibition Palace in which were collected all the useful, cheap articles of household furniture, wearing apparel, and utensils for the poor. A jury, consisting of seventeen members, has just been appointed to examine this class, and make awards. This idea has been much applauded by the French economists; but to those who have seen similar collections in the United States, or in England, the result is far from satisfactory. The French are too fond of detail to be simple and practical, too fond of effect to be cheap. It is much to be regretted that the United States could not enter fairly in competition with France in a field where she is so eminently in advance of all other nations.

While on this subject it will be proper to mention that, although nothing new has transpired in regard to the awards of the juries since my last, it is becoming more and more evident that the owners of important inventions in the United States have made a grand mistake in a pecuniary point of view in neglecting a representation at the Paris Exhibition. Every important invention brought here will be manufactured in France on a large scale by French companies before the lapse of six months, and will afford a highly remunerative income to the inventors. The avidity with which these few inventions have been seized by French capitalists, shows the appreciation which is placed upon American inventive genius, and demonstrates sufficiently that if our people will cease to bore the French government with infernal machines for war purposes, and turn their attention to bringing over the hundreds of really great inventions for agricultural and other useful purposes which abound

in the United States, they will not only increase their fortunes, but add largely to the national reputation. There is no proposition more self-evident than that the greatest military nation of the world would certainly never think of looking to an eminently agricultural and commercial people, without army and without wars, for the arms which it is to use in military service; while it is equally evident that the reputation which our people have already established for the invention of practical and useful articles will always gain for them a ready appreciation and a good market. The number and extent of the experiments which are constantly being made in the arsenals and military depots of France would, we think, if known to that class of individuals in the United States who have their attention turned to improved methods of human slaughter, forever deter them from presenting themselves and their machines to be laughed at by the military commissions of France."

Resistance of the Atmosphere to Moving Bodies.

MESSRS. EDITORS—Near the close of the last volume of the *SCIENTIFIC AMERICAN* there were some speculations concerning cars moving on railroads at high velocities. Your statement that there were other forces to encounter more serious than the resistance of the air, was perfectly correct; yet, it is easily demonstrated that the resistance of the air alone is sufficient to prevent the attainment of two or three hundred miles per hour. From investigation, agreeably to the known laws of mechanics, corroborated by experiments, the force of a current of air against a fixed obstacle is found to be nearly 50 lbs. to the square foot, when moving at the rate of 100 miles per hour, which pressure increases as the squares of the velocity. 100 miles per hour is 8,800 feet per minute. And supposing a car to present a front of 100 square feet, we have a resistance of 5,000 lbs., moving 8,800 feet per minute = $5,000 \times 8,800 = 44,000,000$ lbs., 1 foot per minute, or $44,000,000 \div 33,000 = 1,333$ h. p. The amount of power necessary, to overcome the resistance of the air alone, when moving at the rate of 100 miles per hour. If the car should move 200 miles per hour, the resistance will be quadrupled, and the velocity doubled; that is, 20,000 lbs. moving 17,600 ft. per min. = $352,000,000$ lbs. 1 foot per min., or $352,000,000 \div 33,000 = 10,666$ horse power. And when moving at 300 miles per hour, it would require a steam engine of 36,000 horse power to overcome the resistance of the air. Hence we may also deduce the futility of attempting to navigate the air by steam. No balloon can be constructed to carry a steam engine sufficiently powerful to impel it against a current of air.

J. B. CONGER.

Jackson, Tenn.

[In the articles referred to by our correspondent, we stated the exact amount of atmospheric resistance as he does, viz.: 50 lbs. on the square foot, when the car moves at the rate of 100 miles per hour. We only presented 50 square feet of car frontage, which is nearly correct. We also stated that the atmospheric resistance increased according to the square with the increased velocity of the moving body. He has carried out his calculations of atmospheric resistance at considerable length, but these in no manner contravene any statement made by us. The assertion was made in the *New York Tribune* that if the resistance of the atmosphere was removed, railroad trains could be very economically run at the rate of several hundred miles per hour. We endeavored to correct such an error, and while we candidly gave the precise amount of atmospheric resistance quoted above, we said it was but a small amount of the total resistance which railroad trains had to overcome, and that there were other and greater resistances which also increased according to the square, with an increase of speed in the moving body. Our correspondent agrees with us and he is one whose knowledge of the laws of mechanics is profound. The position we assumed has never been controverted, but attempts were made to correct us by those who ought to know better, by asserting that the atmospheric resistance alone increased according to the square on railroad trains, while all the other resistances increased only with the speed. We then quoted that eminent authority on rail-

road engineering—D. K. Clark—to sustain us, and, while his opinion never was contradicted, his conclusions were evaded. There is not a competent railroad authority in our country, or any other—one acquainted with mechanical philosophy—who will disagree with us. Why should the atmospheric resistance alone increase according to the square, and all the other resistances—concussions, oscillations, &c.—simply increase with the speed of the moving body? Nature's laws are uniform, not capricious.

Our correspondent has long known the *SCIENTIFIC AMERICAN*, and he knows we never could have asserted that the velocity of a moving body could be increased without an increase of propelling force. The golden rule of mechanics is, "The power multiplied by the space through which a body moves in any given direction, must be equal to the total resistance multiplied by the space through which it moves in a corresponding direction." According to this law, the removal of any resistance to a moving body—like a railroad car—enables it to increase its speed in the same ratio, without requiring an increase of propelling force. This is the position on which we have stood, and it cannot be moved, for it is founded on an immutable law. We have therefore directed the attention of our railroad companies to improvements in the "permanent way," thus to remove the most prominent sources of the greatest resistances to railroad trains, and thereby decrease their running expenses, or obtain higher speeds for the same expenditure. Our correspondent presents a formidable array of horse power to move a car at the rate of 100 miles per hour against the atmosphere, viz.: 666 horse for 50 square feet of frontage. It does not look quite so large when we call it one ton two hundred and sixty pounds, moved at the rate of 1 mile 2520 feet per minute, which is the exact amount also. The power of an engine is just in proportion to the amount of steam the boiler can generate in a given time, and if it requires four times the fuel—according to the square—for a double velocity, the distance is passed over in one-half the time, which just makes the quantity of fuel double for a double speed. If the resistance is according to the cube, as is provided for in steamships, then the fuel required for a double speed—with eight times the increase of engine power—will be four times the amount. It has surprised us to hear some engineers making a wonderful ado about the difficulty of increasing the speed of a locomotive when running at a high speed. There is a point of velocity beyond which no engine can run; that point is its maximum capacity to generate steam. An engine requiring 100 gallons of steam per minute to run at a certain speed, will require the boiler to generate 400 gallons of steam, in the same time, to double its speed—that is according to the square. We trust we have always advocated sensible improvements; and it is surely self-evident that every resistance that can be removed on railways is a clear gain. It is, therefore the duty of every engineer to study well all the resistances to moving bodies, so as to know the exact amount of each, in order to remove them. This is the only way to economize, progress, and improve. What we have said has not been in answer to Mr. Conger, but suggestions relating to the laws of mechanics, that have naturally arisen from reading his letter, which will repay the careful consideration of our railroad engineers.

Australian Gold Statistics.

The colony of Victoria, in 1852, with about 60,000 diggers, produced, from two of the principal fields, gold equal in value to £14,000,000; in 1853, with about 80,000 diggers, and about six gold fields, £11,000,000; in 1854, with 100,000 diggers and sixteen gold fields, £8,300,000; and this year, with upwards of 100,000 diggers, and more than twenty gold fields, the estimated product is about £7,000,000, and this is obtained by applying machinery to the re-working the refuse of the old gold fields.—[London Mining Journal.

[This shows that the gold products of Victoria are decreasing.

A live lizard, measuring 19 inches in length, was posted in Somersetshire, directed to Dr. Pettigrew, in London, and actually arrived safe and lively.

New Inventions.

Recent Foreign Inventions.

FRESH WATER FOR MARINE STEAM BOILERS.
—James Biden, of Gosport, Eng., has obtained a patent for feeding fresh water to marine steam boilers, which water he obtains by the condensation of the steam after it has been employed in the cylinders of the engines. This he carries into effect as follows: He leads a pipe from the cylinders into the water outside of the ship at one side, and after carrying it round the stem of the vessel, he causes it to enter the vessel at the other side, and open into a reservoir in the hold of the ship. A pipe opens from the reservoir to the atmosphere, to allow any uncondensed steam to pass off. As the steam from the cylinders passes through the water of the ocean outside of the ship, it becomes condensed, and the fresh water thus produced flows into the reservoir, from which it is pumped into the boilers. This invention is really an outside condenser—the ocean being made the grand cooler. The condenser pipe must be set on an incline to allow the condensed water to flow into the reservoir. An engineer in this city proposed to us some years since, a method of obtaining the same result in an iron steamer, making the lower part of the hull a huge surface condenser. The plan of Mr. Biden, we think, is preferable, as he can use any number of pipes to accomplish the perfect condensation of the steam. Each pipe should be provided with a cock, so as to be shut off, if damaged, from communication with the cylinders.

CUTTING PILED GOODS.—G. Whyatt, of Okenshaw, Eng., has obtained a patent for causing the bed plate, with its straight edge, to be raised and depressed alternately, in order to present the pile of the cloth closer to the cutting shears at such places and at such intervals as may be desirable, to produce the effect of strips in the pile or velvet by cutting the pile shorter in places so presented to the shears. This is a very simple improvement to effect the object specified.

Improvement in Cutting Wood Moldings.

The accompanying figures represent the improved machine of H. & R. S. Schevenell, of Athens, Ga., to whom a patent was granted on the 25th of Sept. last. Fig. 1 is a longitudinal vertical section, and fig. 2 is a transverse vertical section of the machine taken at *y y*, fig. 1. Similar letters refer to like parts.

The nature of the invention consists in the combination of rotary patterns, a reciprocating gate with cutters attached, and inclined planes underneath it, all arranged to effect the cutting out of the moldings in a peculiar manner.

A represents the base of the machine, to the sides of which metallic plates, *a a*, are attached the upper parts of the plates have projections on them at right angles with the plates, in order to form guides, *b b*, which fit in grooves, *c c*, in a carriage, B. The plates, *a a*, and guides *b b*, may be cast in one piece. Underneath the carriage, B, there is attached a longitudinal rack, C, in which a pinion, D, on a transverse shaft, E, gears, said shaft having its bearings in the plates, *a a*. To each plate, *a*, there is attached an upright, *d*, between the two uprights, *d d*, a gate or slide, F, is fitted, the uprights having guides, *e*, on their inner edges, which fit in grooves in the ends of the gate or slide. The upper ends of the uprights are connected by a cross piece, *f*. To the upper end of the gate or slide, F, there is attached a rod, G, which passes through the center of the cross piece, *f*. The upper end of this rod has a screw thread cut upon it, on which a nut, H, is fitted, the nut being above the cross piece. Around the rod, G, and between the under surface of the cross piece and the gate, F, there is placed a spiral spring, I. To the front side of the gate there is attached a plate, J, the ends of which project a short distance beyond the uprights, *d d*. To this plate the cutters, K K, are attached; two are represented, but more or less may be used. The cutting edges of the cutters are made of a form corresponding to that intended to be given to the moldings, fig. 2. To each end of the shaft, E, there is hung a pattern, L. These patterns are constructed by cutting indentations of proper

length into the peripheries of circular plates, so as to form a series of curved projections on the peripheries of the plates. The form of the peripheries of the plates may be varied, however, so as to form different styles of moldings. On the upper surfaces of the guides, *b b*, there are placed inclined planes or wedges, M M. These are directly underneath the plate, J, at

each side of the carriage, B. Each end of the carriage, B, has a projection, *g*.

OPERATION.—The strips designated by N, to be operated upon are clamped upon the carriage, B, directly underneath the cutters, K K; the spring, I, presses the edges of the cutters, K, upon the strips, N, and the ends of the plate, J, upon the peripheries of the patterns, L L. Motion being given the shaft, E, the carriage is fed along by the rack, C, and pinion, D, in the direction indicated by the arrow, and the patterns, L L, as they rotate in connection with the spring, I, give the gate or slide an up-and-down motion, and the strips, N, will be cut in a waved manner thereby, as shown in fig. 1. When the ends of the strips have passed the

cutters, K K, the projection, *g*, on the carriage back of the gate or slide, F, will strike the inclined wedges or planes, M M, and the gate or slide, F, will be forced upward beyond the reach of the patterns, L L. The finished strips are then removed and others secured to the

PATENT MACHINE FOR CUTTING ORNAMENTAL WOOD MOLDINGS.

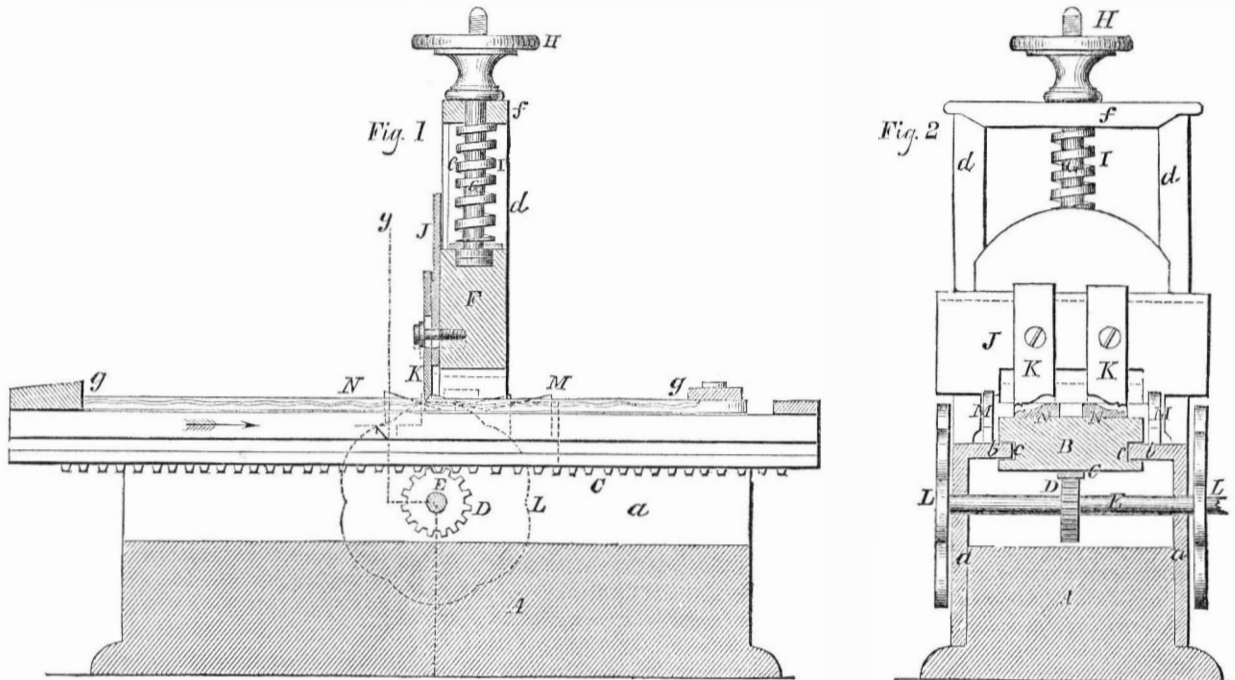

carriage which is moved back to its original position by turning the shaft, E, in the reverse direction, and the stop, *g*, on the opposite end of the carriage will strike the inclined planes or wedges and throw them out from underneath the plate, J, thereby allowing the spring,

I, to force the cutters, K K, down upon the strips, and the ends of the plate, J, upon the patterns, L L. The operation as described is then repeated. See advertisement on another page. More information may be obtained by letter addressed to the patentee.

vertical rods, *j*, are attached to the lower surfaces of the cross bars. The upper ends of the two levers, D' D', are connected by a cross rod, *k*, which passes through a slot, *l*, in the handle or rod, D, of the follower, C. The upper part of the slot, *l*, is straight, and the lower part of zig-zag form, as shown in fig. 2. The top or cover of the case, A, has an aperture, *m*, made through it, as shown in fig. 1.

The implement is operated as follows: The case, A, is filled with corn, and the rod or handle, D, is drawn upward, as shown in the full lines. The tubes, *g*, are then forced into the ground, and the handle or rod, D, pressed downward. As the follower, C, descends, the springs, *b b*, are contracted, and the plates or distributing slides, *d*, are drawn within the smaller case, B. The apertures in the slides are then brought directly underneath the rods, *f*, attached to the follower, and the zig-zag portion of the slot, *l*, operates the levers, D' D', while the rods, *j*, attached to the cross bars, *i*, of the levers are vibrated, and cause the corn to enter the apertures in the plates or slides, *d*, previously to their being drawn within the case, B. As the follower, C, descends, the rods, *f*, force the corn from the apertures in the plates, *d*, down within the tubes, *g*, and leaves each kernel the requisite distance in the ground, (represented by dotted lines.) As the follower is drawn upward, the springs, *b b*, are allowed to expand, and the plates or slides, *d*, return to their original position.

STODDARD'S PATENT HAND PLANTER.

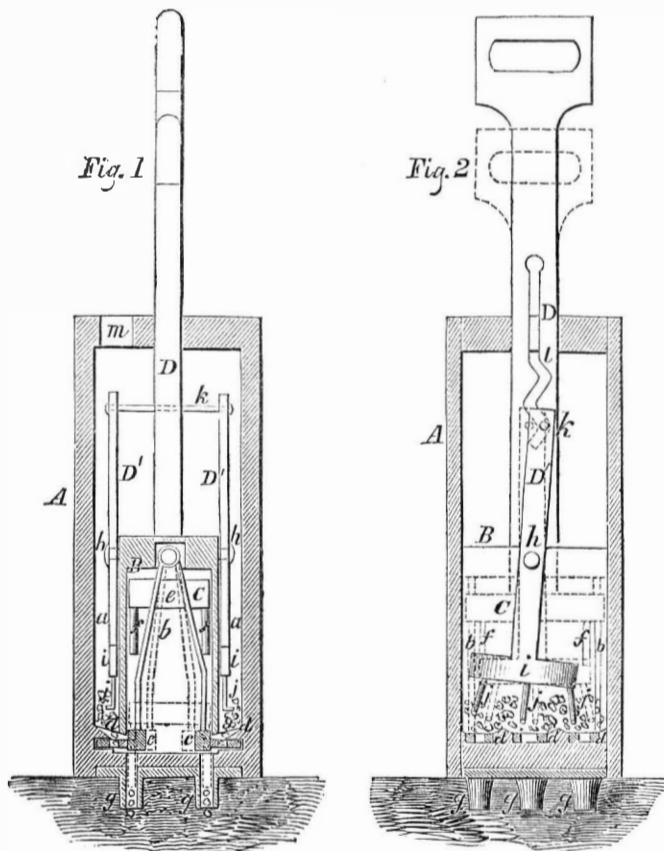

The accompanying engravings represent the improvements in hand Corn Planters, for which a patent was granted to Oren Stoddard, of Busti, Chataque Co., N. Y., on the 26th of June last.

The two figures are vertical sections (taken at right angles to one another) of the implement, and the same letters refer to like parts on both.

A represents a rectangular case of a suitable size, having within it a smaller case, B. Within the smaller case, B, there is fitted a follower, C, to which a handle or rod, D, is attached, and passing up through the top or cover of the case, A. The smaller case B, in one direction is equal to the breadth of the case, A, as shown in fig. 2; but it is narrower in the other direction, as shown in fig. 1, so as to leave a space, *a*, at each side between them. To the upper

part of the smaller case, B, there are attached two springs, *b b*, at opposite sides. The lower ends of these springs are attached to bars, *c c*, to which bars perforated plates or dropping slides are attached, and working through apertures in the lower sides of the case, B, and over the bottoms of the spaces, *a*. The ends of the follower, C, has recesses or notches, *e*, made in it, in which the springs, *b b*, fit. To the under surface of the follower, C, there are attached a series of rods, *f*; any proper number may be used, (probably six would be sufficient—three at each side of the follower,) and through the bottom of the case, A, there are made a corresponding number of holes, over which short tubes, *g*, are secured. To each side of the smaller case, B, there is attached by a pivot, *h*, a lever, D'. The lower ends of each of these levers has a cross bar, *i*, attached to it, and

Some correspondent at Cannelton has sent us a communication containing \$32, without signing his name to it. Will he oblige us with his address immediately?

More information respecting it may be obtained by addressing Mr. Stoddard, at Busti.

Some correspondent at Cannelton has sent us a communication containing \$32, without signing his name to it. Will he oblige us with his address immediately?

More information respecting it may be obtained by addressing Mr. Stoddard, at Busti.

Some correspondent at Cannelton has sent us a communication containing \$32, without signing his name to it. Will he oblige us with his address immediately?

Scientific American.

NEW-YORK, NOVEMBER 17, 1855.

Gross Injustice in the Navy.

It is well known to most of our readers that in pursuance of an act of Congress passed at its last session, a Board of naval officers assembled at Washington, during the past summer, for the purpose of forming a *Retired List*, to be composed of those officers who, in the opinion of the Board, were incompetent for the discharge of their duties. This Board met in secret, kept no record of proceedings, called no witnesses, and heard no arguments. They commenced their session on the 20th of June, and adjourned on the 26th of July. They lost several days by absence of members, and five days on account of Sundays. Their sessions commenced at 10 o'clock A. M., and lasted until 3 P. M. The Board were required by the act of Congress to make a careful examination into the efficiency of every officer. Their whole working time was less than 140 hours, during which period they adjudicated upon the claims of 712 officers—so that the "careful examination" amounted to an average of about ten minutes for each, the result of which was to seal the fate of many a good fellow who had served his country long and faithfully.

We have thus particularly called attention to this secret "Star Chamber" tribunal, because its action has been to declare incompetent, unworthy of promotion, and an incumbrance upon the Navy, the very men who for many years past and up to the present time, have done, and are doing, so much for the interests and reputation of our country. We refer particularly to those officers who have especially distinguished themselves by their high scientific attainments, Lieut. Maury, of the National Observatory, and Lieut. Maffit, who is, probably, the most eminent hydrographer in the service, and has distinguished himself by his services in connection with the coast survey.

Notwithstanding the Executive, by its approval of the decision of the Board, has declared these officers incompetent (and incompetency, in naval language without specification, means drunkenness, mental incapacity, cowardice, &c.) and as unworthy of further promotion, it has yet ordered them both to continue their respective important and responsible duties, thus recognizing them as better fitted for their respective posts than any other officers on the list. To use the language of the Philadelphia *Inquirer*, we regard the action of the Board "as an insult upon the virtue and general intelligence of the country."

There seems to have been, on the part of the Board, a feeling which induced its members to take advantage of their irresponsible power—to strike down almost every officer who had in any way distinguished himself by his scientific attainments; and in doing this they all took very good care to look out for No. 1, as will be evident from the following statement, which any one may verify for himself by examining the naval register. Of the officers whom the Board was called to scrutinize there were 362 on the naval list ranking above the youngest lieutenant on the Board, while below on the list were 332. Every one of the 360 of the higher rank who was removed or retired, promoted or advanced one or more members of the Board, and we accordingly find that they black-balled 138, but on the lower list—the retirement of any member of which would not affect the Board—we find they only retired 46 out of 332.

Among the officers promoted by the action of this Board, in displacing men of whom the country is justly proud, we know of those who, for the past few years back, so far from rendering any service to the country, have been engaged in other pursuits, in no way allied to the Navy.

In regard to Lieut. Maury—and the case is equally true of other distinguished officers—there is but one sentiment throughout the country, and that is, that gross injustice and partiality has been displayed. His eminent services have been acknowledged by almost every Government in Europe. Prussia and

Sweden have struck gold medals to his honor. The Russian Ambassador, during the last summer, has publicly thanked him by the direction of his Government. England has not been sparing of her tribute of admiration in Parliament, and has adopted his plans in her own Navy, while the great French Industrial Exhibition awards to his charts her highest premiums. His own country, on the contrary, declares him a clog and an incumbrance on its Navy, and unworthy of promotion. We trust Congress will set this matter right. Better dispense with the services of the entire Board of "ten minutes inquisitors" than of this eminent man.

We understand that it had been proposed in Philadelphia that in case Lieut. Maury retired from the Observatory, to present him with a testimonial of \$50,000, as an acknowledgment of his services, and as a mark of the disapprobation of the action of the Board. We doubt not that this sum might easily be raised in our great commercial cities. Yes, twice that if necessary.

Cast Iron Shot Tower—Shot Making.

A tall cast-iron shot tower has just been erected in Center street, this city, and is the only one of the kind in the world. It is under the superintendence of J. McCullough, who for thirty years has been celebrated for the manufacture of shot. We paid it a visit a few days since, examined its construction, and witnessed the various processes connected with shot making. The designer and builder of the tower is James Bogardus, the original inventor of cast iron houses—his factory on the corner of Duane and Center sts. being the first entire cast-iron house—story upon story—ever erected. The plan of the tower is novel. Its base is 25 feet in diameter, and 18 feet deep below the surface of the ground—resting upon a hardpan of sand. The walls of the underground foundation are of solid masonry, four and a half feet thick. The cast iron tower above is anchored to huge stones in the wall, each having two holes bored through it near the center, and eighteen inches apart. These are twenty in number, and extend eighteen feet down through the wall. A wrought-iron shaft, two inches in diameter and 18 feet long, is secured in each hole. These shafts terminate above the stone foundation in holes at the base of the lower tier of cast-iron columns, which are firmly keyed to them. There are ten cast iron columns on each tier; each of the lower columns is anchored to two of the wrought-iron shafts. The lower tier of cast-iron columns support the entire superstructure, and they are of sufficient strength to sustain a weight of 28,000 tons. Upon the tops of the first ten of the columns there rests a cornice made in ten sections—every pair of sections meeting over the center of a column. Upon the lines of juncture stand the succeeding tier of columns, in the same line with the lower tier. All the cornice pieces are bolted together, making them—as it were—one piece, and each upper column is bolted to both the cornice sections on which it stands, and also to the column underneath. Upon the second row of columns rests another cornice, and upon it a third row, and so on to the height required, each ascending tier of columns standing and bolted on a cornice, and supporting a cornice above. The columns are 15 feet 3 inches long each, making, with a cornice, 18 feet as the height of each story of the tower. There are 11 stories composing the entire structure, which, with the extra top cornice, makes the whole height of it above ground 174 feet—with the 18 feet depth of well 192 feet; this allows of a sufficient altitude for casting the largest sized shot.

For the first two stories of the tower the spaces are left open; the remaining nine are filled in with brick, four inches thick, in which are inserted five windows in each story. This brickwork is only a paneling, not intended to add to the strength of the building, but merely to shelter the workmen from the weather. The columns have flanges on them, with corresponding sections of cornice, so that each panel of brickwork is neatly and firmly inserted and cemented into the cast iron work. Each panel has therefore great strength in itself, and does not depend for security upon another part of the building.

The outside diameter of the tower is 21 feet

at the ground. It tapers at the rate of six inches to the story. The outside diameter at top is 15 1-2 feet—the inside diameters are two feet less.

The total weight of the iron employed in its construction is 208,300 pounds. Its entire weight is less than the 170th part of what the first story columns can sustain. Indeed, such is their strength, that the tower might be continued with safety until, with the same taper, it would terminate in a point—over six hundred feet high. We really would like to see such a tall tower or steeple erected.

The columns and cornices—it will be noticed from the description given of their method of fastening and combination—are so united as to render the tower equal in strength to what it would be were it a single casting of metal. This is the principle on which all Mr. Bogardus' buildings are erected. Every alternate column may be broken, and the stability of the remainder not endangered.

MAKING THE SHOT—The casting of the columns for this tower was commenced on the 15th of August last, and shot was cast in it on the 22nd of last month. On entering the tower from Center street, the first thing which arrests the visitors' attention is a large circular wooden tank on the middle of the floor, filled with water, and boiling as violently as if it were heated with a steam pipe at its bottom. On a little closer inspection it will be observed that the ebullition is caused by a constant shower of shot falling into the water from an elevated story of the tower. The larger the shot to be cast, the greater is the distance required for its fall. At the top of the fall a quantity of lead is kept in a molten state in a large iron pot heated by a furnace. This is poured with a ladle into a hollow colander of sheet iron, the colander having holes in it corresponding to the size of shot to be made. The surface of the lead becomes covered with a spongy crust called cream, which is used to coat over the bottom of the colander, to prevent the lead from running through too rapidly, whereby it would form oblong spheroids, instead of round drops. The lead passes through the holes of the colander in fine threads, but forming in globules at the under surface of the colander, and dropping down in a spherical shower into the large tub of water described, cooling in its descent.—This method of making shot is said to have originated with a plumber named Watts, in Bristol, England, who, about the year 1782, dreamed he was out in a shower, and the clouds rained lead instead of water. This incited him to try a successful experiment from the tower of a church with some molten lead. This story may be true, and it may not. The process, however, requires both care and skill in the management of the colander into which the molten lead is poured.

The shot is lifted with a copper ladle from the tub into which it falls, and placed on an inclined board to drip; from this it slides into an open iron box, heated with steam, where it is dried. The color of the shot is now a dull gray, and although it might answer perfectly for use, it must be polished for market—like a piece of furniture. This is done by placing it in an angular iron barrel on a rotating shaft, with some fine plumbago. The action of the shot upon one another, in this rotating *rumble*, polishes them finely, and gives them a dark clear surface. Three of such polishing barrels are used in this tower.

The process of separating the perfect from the imperfect shot is the next in order. The shot, after coming from the polishing barrels, is placed in small quantities on very smooth inclined ways, having sides, but open at the upper and lower ends. Two of such ways are at present used in this manufactory, each requiring one attendant. When placed on these inclined ways, the perfect shot run rapidly in straight lines to the bottom into a bin, while the misshapen shot move with a zig-zag motion, or do not move at all. The attendant, who uses a brush of the width of the incline, knows about the time required for the perfect shot to run into the bin, and he then sweeps back those that are defective into a receptacle at the head of the incline. The shot which we saw separated, contained a very small amount of defective ones in proportion to the quantity separated. After the perfect shot are thus se-

parated from the imperfect, the next process is the separating of the different sizes—they not being uniform in one casting. This is done in vibrating metal sieves, or bolts of different sizes. Two of these were in operation; they resemble a chest of drawers hung upon rockers. The sieves are set one above the other the largest size uppermost, and the shot is fed in by funnel (two on each separator) on the top. When it is poured into the funnel, the attendant rocks the sieve chest by a handle, when the largest shot are retained in the top drawer, and the smaller pass through their separate sieves or bolts into their respective drawers. From these they are taken and placed in small canvas bags, according to their number, from one, upwards, and are ready for market. These are the whole processes of shot making.

Mr. McCullough calculates that the capacity of his tower is equal to the making of five thousand tons of shot per annum. The business of shooting shot must be great and very active in our country, as a large number of persons are now employed in this establishment, and the building is not yet quite finished. We saw more than \$20,000 worth of lead in bars, on the floor, waiting to be made into leaden rain drops, to carry death to thousands of pigeons, partridges, plovers, prairie-hens, turkeys, snipe, wood-cock, duck, and other fowl. Three hands were also employed in this establishment molding bullets of different sizes—each mold piece contained 132 molds of varying size. The molten lead was poured in like tallow into common tallow molds; the molds opened horizontally, and dropped the formed bullets into receivers below: this work was carried on with great rapidity. There are now three shot towers in this city, one of brick, one of wood, (gaunt ungainly structures,) and this cast-iron one, which, from its fluted columns and beautiful cornices, is an object of ornament to the city.

GREAT FAIR OF THE AMERICAN INSTITUTE Last Week.

The American Institute Fair for 1855 closed on the 13th inst., after one of the most successful seasons that the Institution has ever enjoyed. The exhibition has been open for a little more than a month. The number of admissions, free and paid, have been about two hundred thousand. Nothing definite has been done by the managers in reference to the lease of the Palace for next year, but it is understood that, if possible, it will be secured. If such should be the case, it is probable that great efforts will be made to render the exposition of 1856 one of greater magnitude and thoroughly national in its character. If our inventors and manufacturers would take hold with good will, they might produce an exhibition purely American in its character, that would astonish the world. We hope they will do so, and if they do, we predict that the admissions next year will reach the number of, at least, one million of people.

There is talk of the purchase of the Crystal Palace, for exhibition purposes, by the American Institute. The latter is in a very flourishing condition, and fully able to do so.

One of the stirring events at the Palace last week was the parade and drill of the New York State Militia, Col. Lyon. The troops manœuvred in the north and south naves of the Palace. Their movements were witnessed by a very large assembly of ladies and gentlemen, who crowded the galleries, and all other available points. The loading and firing by soldiers called out much applause; of course no powder was used in their rifles, but the capping and snapping was so finely done that it evinced their skill with powder and ball.

Mr. Henry Randall, inventor of a plan for an elevated city railroad, obtained permission to erect a track within the Palace, above the heads of visitors, for the purpose of showing his invention. The track sweeps the entire circumference of the building, and is in length perhaps one-third of a mile. After spending several thousand dollars, the construction was brought to a stop, and the railway remains unfinished. It is too bad. It would have formed quite a feature of the exhibition.

The gas engine, we are again sorry to report, has failed to operate successfully. Beyond an occasional start of 20 or 30 revolutions, or a run of 5 or 10 minutes, having great

difficulty to carry its own weight, it has done nothing. We sympathize with the inventor, Dr. Drake, and trust that he may hereafter have better luck. We have no faith whatever in his ability to make an economical gas engine; still, we are ready to believe when we see it actually realized. Unlike Ericsson and his hot air coadjutors, Dr. Drake has put forth no brag-gadocio statements in regard to his invention, but works on quietly and hopefully, and whether ultimately successful or not, deserves much credit for his untiring perseverance. Dr. Drake is confident that he can make a successful gas motor. He has been quietly working at his project for many years. He asks no favors, he expects no converts until he succeeds in practically demonstrating the correctness of his theories. His invention is certainly ingenious, and he has our best wishes for its success.

The Cloud Engine folks having taken steam from the main boiler at the Palace, and found the supply insufficient, went to work and put up a portable boiler of their own, and then used the steam from both. But somehow luck has been against them, and the engine went no better. Take the performances of the machine altogether, it has done but little better than the Gas Engine. Notices are stuck up that cloud engines will be built to order, and guaranteed to make a saving of fifty per cent. We think it doubtful whether any one has been sufficiently convinced of its advantages by the movements of the specimen at the Palace, to make extensive purchases. No test has been made of its power; it has not even been connected with the main shaft. It has run as a mere toy. Perhaps there is some explanation for the ridiculous show thus far made, with which we are not acquainted. If the owners can apologize for it, we shall be happy to acquaint our readers, for we have no wish to do any one the least injustice. We were much pleased with the first performances of the Cloud Engine; we hope yet to become acquainted with its good qualities, if it has any.

Knitting Machines.

Mr. Geo. Whipple, No. 23 William street, N. Y., exhibits some of Ellis' patent machines for knitting stockings. They are curious little automatons, and their operations attract a great deal of attention, from the fair sex particularly. The old ladies seem rather suspicious in their examination. They turn over the work, pull it, stretch it, and subject it to a variety of tests, in order to make sure that they can really believe their eyes. But all who examine seem to become satisfied that the stockings are knit firmly, the same as by hand, only better. These machines make stockings at the rate of two complete pairs per hour, taking one thousand stitches a minute. All that the operator does is to move a small treddle with the foot. Different kinds of material can be used with facility, such as woolen yarn, silk, cotton, &c. Price of machines \$100; an extra charge is made for the right to use it, but just how much the attendant could not inform us.

Pipe and Tube Making Machinery.

Webster's Patent is a new invention now exhibited for the first time. The rolling is done by means of a large open cylinder, within which, and geared to the cylinder, a couple of small rollers are placed. The inventor states that 10,000 feet of tin tubing may be formed in one day by a single man. 250 feet is an ordinary day's work. This improvement is applicable to the making of locomotive tubes, stove pipes, &c. It does the work well, and is very simple in construction. Webster & Miller, exhibitors, 67 Nassau street, New York.

Mann & Weeks, of Morrisania, Westchester County, N. Y., exhibit one of Ostrander & Webster's tube machines—an excellent invention, but not very recent. It makes all kinds of pipes and tubes with great facility, is compact, simple, and cheap.

Windmills.

The only one shown in the Fair is the Self-Regulating Windmill invented by Dr. T. G. Johnson, No. 196 Bridge st., Brooklyn, N. Y., illustrated in No. 3, present Volume Sci. Am. It is a very ingenious invention, and presents a handsome appearance.

The principle upon which the regulator operates is centrifugal force of weights acting against the tension of spiral springs, the tension of the springs taking the place of the force

of gravitation in ordinary regulators, such as are used on steam engines. The tension of the springs keeps the sails turned or set to receive the wind, and the centrifugal force of the weights, whenever the velocity becomes too great, turns the sails out or edgewise to the wind.

The regulator, in its construction and operation is exceedingly simple, and acts upon precisely the same principle of the one so thoroughly tested and universally used upon all kinds of machinery. This improvement is one of the latest and best of its class. Now first exhibited. Patented 1855.

Improved Vise.

No screw is employed in this vise, but the movable jaw is attached to a sliding beam which is furnished with a rack and pawl. In order to close the vise, you push the movable jaw up towards the other with the hand, and the pawl holds the same; the grip is tightened by turning the beam, the head part of which is cam-shaped for that purpose. Raise the pawl with the finger and the movable jaw opens, being self-acting; the two jaws are connected by cross levers. This vise is opened, closed, and adjusted, much quicker than the screw kind; its cost is also less. It is a good improvement. R. W. & D. Davis, inventors.—Exhibited for the first time by Wm. H. Schofield, agent, Yellow Springs, Green Co., Ohio. Price \$4.50 to \$17.50, according to size. Patented 1855.

Grate Bars.

The Salamander Grate Bar Co., exhibit samples of Van Syckel's patent bars for steam boiler furnaces and other fires. The improvement consists in locking the bars together by means of mortices and dowels cast on their sides, in such a way that if one bar gets heated more than another it cannot warp or spring out of place, and so burn. Bars thus made last longer than those of the ordinary construction. This improvement is in use on nearly all of our ocean steamships. Patented in Europe through the Scientific American Patent Agency. Office of the Company No. 30 Pearl street, N. Y.

Hand Corn Planter.

This implement is a little dry looking thing externally, but internally presents an exceedingly simple arrangement for forming the hole in the soil, dropping the desired number of grains of corn into the same, and then covering them up. In operating, an up-and-down movement of the tube is only necessary. The end of the tube is thrust down into the soil, and makes the hole, it also takes up dirt enough to cover the corn; by the act of raising the planter out of the soil, the corn is discharged and covered. This machine, in its construction and operation, is said by the inventors to be better than those in use from the fact of its employing a swinging or turning seed distributing plate instead of a horizontal sliding one. The covering device is also more simple, and the whole contrivance much cheaper of construction than any others in use. Coleman & Williamson, 6 Wall st., N. Y., agents. First exhibition. Patented 1855.

Barlow's Patent Circular Saw.

This improvement consists in grooving the faces of the saw teeth from their points inwardly, forming thereby acute cutting edges or double fleams at their sides. Thus constructed the teeth act upon the wood like so many gauges, cutting their way through, not tearing it, as do the common saws. The result is that the stuff comes from the saw with its surface planed off about as smooth as can be done with a smoothing plane. Saws thus made are adapted for all kinds of work, splitting, cross-cutting, &c., no change at all in the set being required. We saw it cut some veneers of hard wood thin as paper, and many other specimens, with perfect success. It is one of the best improvements in circular saws that we have ever seen. The inventor has a convenient little tool with which the grooves are cut and sharpened. Price of shop rights for the saw and the tool, \$25. Patented 1855. First exhibition. A Conger, agent, 345 Broadway, N. Y.

New Mode of Hanging Mill Saws.

The improvement consists in placing behind the saw a thin plate of metal, called a guide plate, against the edge of which the saw moves up and down. This guide plate looks like a second saw, only it has no teeth. It is of the same width, thickness, and length as

he saw, but remains stationary. The inventor states that his method has all the advantages of the mulley rig, besides other features which the latter does not possess. The fender posts and other appurtenances are dispensed with, and the expense of the mill cheapened by some \$200 or \$300. A substantial 4-horse power mill is furnished for \$750; larger sizes higher cost. Charles B. Hutchinson, Inventor. Exhibited for the first time by Hutchinson & Co., Auburn, N. Y. Illustrated recently in the SCIENTIFIC AMERICAN. Patented 1855.

Improved Mill Stone Dress.

Mr. W. P. Coleman, of New Orleans, La., exhibits a small operating grist mill, the peculiarity of which consists in the dress of the stones. The grooves have a curve which is contrary to the direction in which the stone rotates; the inventor claims that in this manner the grain is longer detained upon the stones, and that the grinding surfaces are always kept well supplied; the result is a great increase in the quantity of grain that can be ground. The mill at the Palace certainly works well.

The awards of prizes we shall probably publish next week.

Railroad Bridges—Terrible Accident.

On the 1st inst. a large excursion train containing about 600 persons left the city of St. Louis, Mo., to celebrate the opening of the Pacific Railroad on a trip to Jefferson City. They all departed "merry as a marriage bell," but alas! the scene of joy was soon changed to one of sadness and mourning. When the train was crossing the bridge over the Gasconade river—about 35 miles from Jefferson City—its timbers gave way, crash upon crash, precipitating the engine and the cars into the river, instantly killing about 24 persons, and terribly wounding twice that number, among whom were some of the most distinguished citizens of St. Louis. The bridge was about 30 feet high, and was a substructure of scaffolding put up as a temporary affair. The timbers of it do not seem to have been tested; it was a fatal oversight. The directors of this railroad were in too great haste to have it opened, and they ought to be held responsible for their conduct. The chief engineer, T. O. Sullivan, was among the killed, and he it was who should best have known the danger. Two other bridges on this road have since been carried away with freshets, and from the accounts published of their construction, we judge that this road has been most unscientifically engineered. It is a most dangerous, cruel, and short-sighted policy to build cheap, frail, railroad bridges.

Patent Telegraph Case.

In the U. S. Circuit Court, Boston, on the 31st ult., Judge Curtis gave a decision in the case of Wm. B. Clum, vs. Chas. H. Brewer & Baldwin, F. O. J. Smith and John T. Smith, et als. This was a case of a bill of equity brought by the complainants, as assignees from Prof. Morse, of a right to use said Morse's telegraphic inventions on a line from Boston to Provincetown, and asking to enjoin the respondents, who were erecting and using a telegraph between the same places, under a license to use the same inventions, from F. O. J. Smith, Esq. The ground taken by the complainants was that said Smith had no interest in said inventions, and could give no licenses. After a full hearing of both parties and an investigation of Smith's title, the Court,—Justice Curtis, decided that Smith was and is the legal and equitable owner of an undivided one-fourth part of all said Morse's telegraphic inventions, and as such, entitled to grant valid licenses to defendants to use the same, and refused to enjoin the respondents.

This decision is an important one, and will be received with much interest by all who are interested in the telegraph business of the country.

A Light Metal.

Dr. Roscoe, of Heidelberg, read before the British Association a paper on the "Formation of the new metals, strontium, calcium, lithium, aluminum, &c., from the chlorides of those substances." The metal lithium, he said, was the subject of much interest, from the fact of its being lighter than water or rock oil, in which it is preserved. One great quality of aluminum was its sonorousness; exceeded in

sharpness of sound, when struck by a metal instrument, the finest bell-metal.

Curious Facts about a Book.

Subscriptions are now being received in London for the two forthcoming additional volumes of Macaulay's History of England, which were announced to issue December 4th. The Liverpool *Albion*, in noticing the fact, says that the subscription will undoubtedly reach 40,000, and that the day of publication will be postponed, and that the cost to the public of these 80,000 volumes (40,000 copies,) the price of the work being £1 16s., would be £70,100; and, if placed in a line, side by side, the thickness of each being two inches, they would extend more than two miles and a half, the exact length being 13,333 feet four inches. Piled one upon another, they would tower to an altitude which would be to the highest pyramid at Giza as "Ossa to a wart," and more than three times the height attained by the aeronaut Gairner when he made his parachute descent. It is difficult to convey an easily realized notion of what the height of such a pile would be, as if St. Paul's Cathedral, the Monument, Pompey's pillar, and the great Pyramid were all placed one upon another, their height would not amount to more than a tenth of that of the books. Their weight, estimating each at two pounds, would be 71 tons, 8 cwt., 64 lbs., about eight times that of the great bell of St. Paul's and Tom of Lincoln together, and considerably more than that of the great bell of St. Ivan's at Moscow, the largest in the world except that of the Kremlin, which has never been suspended, though many engaged in the attempted operation have been hung!

History of Wood Paper.

MESSRS. EDITORS—There has been much said and published during the past year on the subject of "wood paper," and I believe it has been treated by you, and in many other journals, as a novelty in the United States.

I readily admit that improvements of machinery, and a close study of chemistry, have aided in producing a better quality of wood paper, and those who have thus pursued the subject of a triumph are worthy of thanks, for every improvement which cheapens so important an article as paper confers a public benefit. In 1830, in company with Lewis Wooster, Esq., now of Wisconsin, I commenced the manufacture of wood paper, and we succeeded so far as to make a very decent printing paper, on which an edition of the *Crawford Messenger* was printed. We also made a beautiful and strong article of wrapping paper, and many tons of book board of superior quality. We used mainly the lime and aspen woods, and by a process exceedingly simple, I was enabled to make tons of shavings in a very few hours. We obtained a patent for our process, but Col. Magaw, the inventor of straw paper, contended that our use of alkalies was an infringement of his patent, as his specifications read, "straw, and other vegetable substances." He, therefore, threatened us with an injunction and suit, and as he was rich, and we without the staple means of contention, we concluded to seek other modes of a livelihood. I am glad other minds and hands have taken up the subject, and have no doubt that for many purposes it will afford a cheap and valuable material, whether it shall ever take a place among the finer papers or not.

JOSEPH. E. HOLMES.

Newark, Ohio, November, 1855.

Another Medal to Prof. Morse.

The Emperor of Austria has sent a massive gold medal to Prof. Morse, as a testimony of esteem for his genius as displayed by the invention of the "electro-magnet telegraph." This is the fourth token of acknowledgment from European sovereigns accorded to and received by Prof. Morse.

Wheat Cultivation.

Prof. Mapes, in a recent address at the Indiana State Fair, stated that the wheat crops of Ohio had fallen from 35 to 15 bushels per acre. This statement is denied to be true by the editor of the *Ohio Farmer*. He asserts that the average amount of wheat raised per acre in Ohio is now greater than ever it was, and he gives statistics to prove his assertion.

Science and Art.

Glycerine; Its Uses.

In a paper read at the Glasgow meeting of the British Association, Mr. G. F. Wilson stated that this very remarkable substance might, by distillation, be obtained pure, in very large quantities, and showed it to be applicable to a variety of very dissimilar purposes, such as a solvent of quinine, as a substitute for honey in Shadbolt's process in photography, as a substitute for cod liver oil, as a cheapener of the alcohol used in spirit lamps, as a remedy for chapped hands, sunburnt faces, and for the irritation experienced by many after shaving, as a preservative of the colors of some objects of natural history, especially of the brilliant colors of the scales of fishes, &c.

Mr. Wilson's paper thus concludes:—

"Though a variety of uses for pure glycerine have thus been mentioned, yet when we consider its power as a solvent, its blandness, and freedom from all irritant, acid, and fermenting properties, we must feel that not a tithe of its uses have yet been developed.—Pure glycerine will hereafter be considered among the most valued of modern products; and produced, as it will be, in great quantities, it will be recognised in the arts, as well as in medicine, as a new real blessing to mankind."

Glycerine exists in fixed oil, lard, &c., and is obtained during the process of saponification. It is the fluid which is left behind in the mother liquid in making soap. It has a sweet taste, and is soluble in water, and on this account is used in perfumery for the hair. Its use is exceedingly limited, consequently it is sold by druggists at a pretty high price. According to Mr. Wilson, its virtues are numerous.

Saltpeter and Lead.

The materials of warfare—saltpeter, charcoal, and lead—having advanced since the commencement of the war, in the former instance to upwards of £10 per ton, and in the latter from £3 to £4, this progressive rise has produced a somewhat corresponding effect on the opposite side of the Atlantic, and has already begun to tell upon prices. Since the arrival of the *Baltic*, lead at New York advanced from 3d. to 3 1-2 per lb. The stock of saltpeter in America is small, consequently the upward tendency of price continues, although Congress, admonished by the deficiency of material during the revolution, as well as in the war of 1812, has for some 20 or 30 years past appropriated \$20,000, about £4000, per annum for the purchase and storage of saltpeter.—This precaution is alleged to be expedient, as the most prolific mines on the tributaries of the Ganges are under the control of England.—[London Mining Journal.]

Improvement in Power Presses.

Figure 1 is a perspective view, and fig. 2 a section of the operating levers of an improved Press, for which a patent was granted to Elias Davis, of Montpelier, Vt., on the 23d of May, last year.

The nature of the invention consists in arranging a series of horizontal and vertical knuckle joint levers below the screw and the bed plate, and so combining them that as they operate, a powerful progressive upward pressure is exerted, and the article to be pressed is made to assist in pressing itself by its gravity.

A is the frame of the press; C C, are the two main knuckle joint levers placed diagonally across the press, *a a*; the outer ends of these levers are so formed as to fit snugly in, and are secured to sockets formed in top of levers D, fig. 2, *d*, fig. 1, and thus form knuckle joints. The lower ends of levers D, have semi-circular projections, *b*, fig. 2, on them, which fit into semi-circular sockets in the bottom of standards, *c*, forming knuckle joints also. The inner ends, *b b*, fig. 1, *d d*, fig. 2, of the main levers, C, play up and down in the central pedestal open box, E. F is a sliding frame of the press, and the box, E, is secured in the center of the lower sliding cross piece, *e*. The ends, *d d*, fig. 2, of levers, C, have each two sockets formed in them—one at the top, the other at the bottom. The bottom sockets fit on semi-spherical projections in the bottom of

box, E, and form ball and socket joints. The top sockets of the ends, *d d*, receive the spherical lower ends of two small knuckle joint levers, C C, also fig. 2. The upper ends of these short levers fit into corresponding sockets in the vertical hollow standard, H. All the levers are thus formed to work in knuckle joints. The standard, H, has two flanges, *f*, which fit in slots, *g*, in the sides of box, E; they

DAVIS' PATENT ACCUMULATING POWER PRESS.

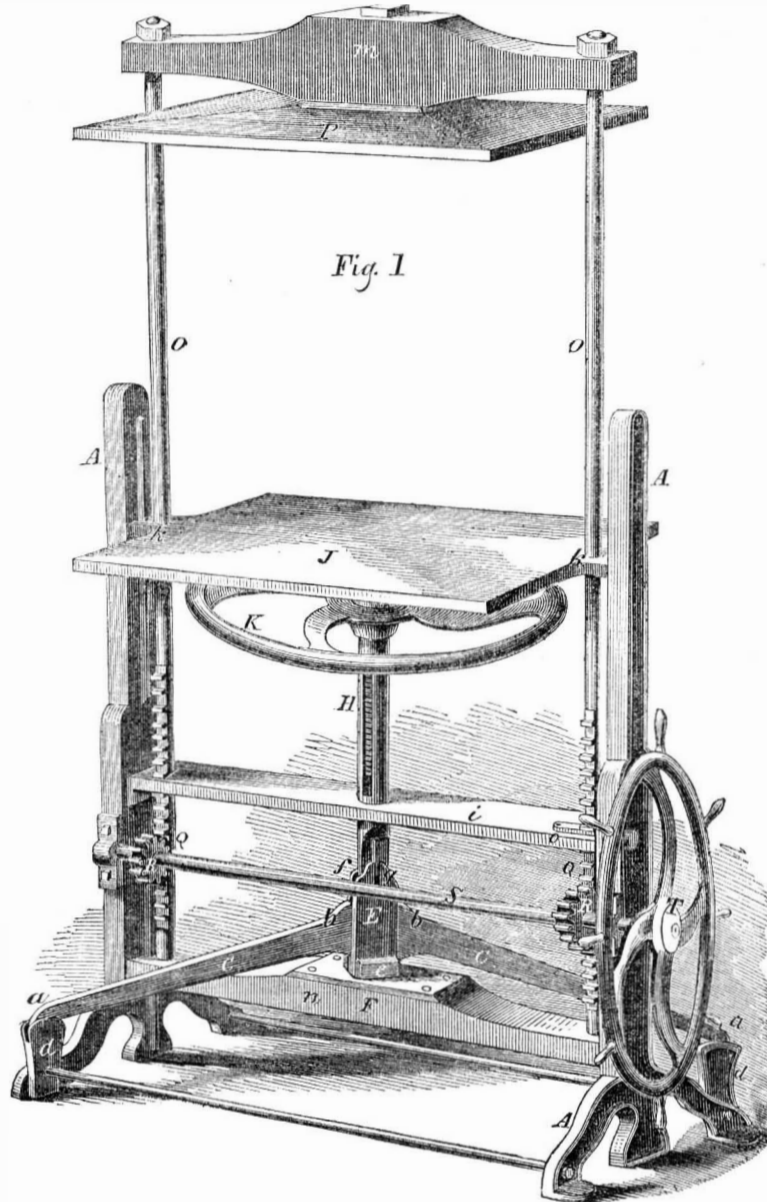

work the screw of the standard to raise and lower plate J. The upper part of standard H, fits snugly into a recess in the hub of wheel K. By thus connecting the hollow standard, H, with the wheel, K, the power of the levers is transferred to the plate, J, to be exerted on the article to be pressed. O O are united rods of the sliding frame, F. They are united together at the top and bottom by the cross piece, *e*, fig. 2, *m*, fig. 1, and by a middle piece, *i*, through which the hollow standard, H, moves freely.

The top cross piece carries the pressing follower, P, which is secured to it by a ball and socket joint, not shown. The platform plate, J, has guide lugs, *k k*, that serve as guides for the rods, O O, of the follower. Q Q are racks on those rods, and R R are small pinions on the shaft, S, of the lever wheel, T.

OPERATION.—The article to be pressed is placed on the platform plate, J, and the space between it and the follower, P, is blocked up, and the movable frame is then raised by turn-

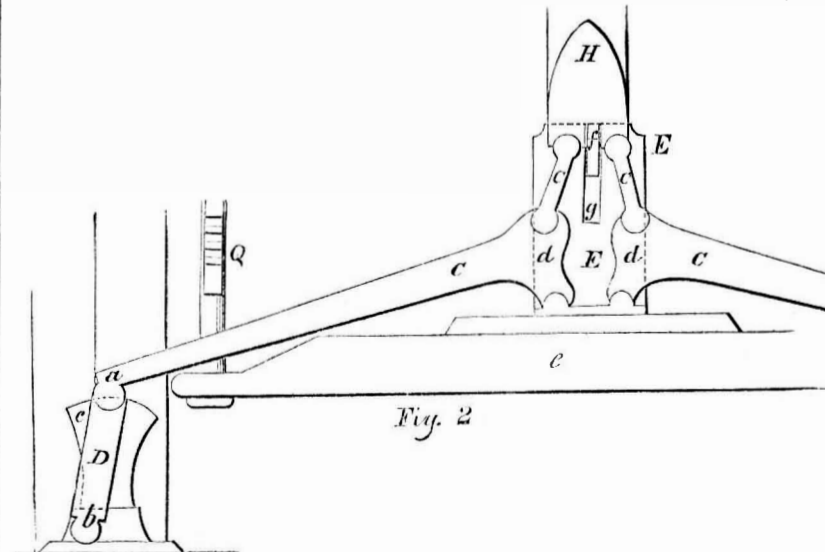

ing wheel T. The small catch, *o*, fig. 1, on the center brace, *i*, is now inserted under a tooth of rack Q, and the sliding frame, composed of the rack bars and the follower, P, is held in position. The plate, J, is now raised by turning the nut wheel, K, when the small levers, C C, assume the angular position shown in fig. 2. The press being thus arranged with the article

to be pressed placed snugly between the plate, J, and the follower, P, the catch, *o*, is withdrawn from under the tooth of the rack, when the follower, P, gradually descends with its entire frame by its own gravity, pressing the article between it and the plate, J. The effect of the pressure upon the plate, J, is to thrust the large levers, C, into a horizontal position;

this tends to make the small levers, C, assume a vertical position, which makes them thrust upward, and exert a counter pressure to the descending follower, thus pressing the article between two forces exerted in opposite directions. If the press should settle completely down, by the compression of the article without completely pressing it, the follower is raised again, more blocks put in, and the article, as before described, re-submitted to a severer pressure. The pressed article is taken out of the press by giving the wheel, T, a few turns, to elevate the pressure block.

One of these presses is on exhibition at the Crystal Palace, and more information respecting it may be obtained by letter addressed to Mr. Davis.

Iron Region of Lake Superior.

A correspondent of the *Detroit Free Press* writes as follows in regard to this section of country:—

"This is, emphatically, an iron country. In every direction where the steps of the explorer penetrate, iron ore of more or less purity is found. Its veins ramify through rocks and stones. The whole soil is impregnated, and frequently the sands of the shore are tinged with its oxyd. Boulders of iron are scattered at random. On the highest part of the 'Jackson mountain' I remarked them, bare and glistening in the sun. An Englishman, but just arrived in America, who has had long experience as a manufacturer, and has possessed facilities for extensive observation of iron mines in England and on the Continent, was directed by E. K. Collins to the iron region of Lake Superior. He came unbelieving, thinking the story of these iron hills was a 'Yankee humbug.' The utmost stretch of his expectations could not reach the reality which he found. He says that the truth, told in England, would be scouted as arrant imposture—that the 'iron men' of the Old World could not conceive of deposits of iron on such a stupendous scale."



Inventors, and Manufacturers

ELEVENTH YEAR!

PROSPECTUS OF THE

SCIENTIFIC AMERICAN.

This work differs materially from other publications being an ILLUSTRATED PERIODICAL, devoted chiefly to the promulgation of information relating to the various Mechanic and Chemic Arts, Industrial Manufactures, Agriculture, Patents, Inventions, Engineering, Millwork, and all interests which the light of PRACTICAL SCIENCE is calculated to advance.

Every number of the SCIENTIFIC AMERICAN contains Eight Large Pages, of reading, abundantly illustrated with ENGRAVINGS,—all of them engraved expressly for this publication.

All the most valuable patented discoveries are delineated and described in its issues, so that, as respects inventions, it may be justly regarded as an ILLUSTRATED REPERTORY, where the inventor may learn what has been done before him in the same field which he is exploring, and where he may bring to the world a knowledge of his own achievements.

REPORTS OF U. S. PATENTS granted are also published every week, including Official Copies of all the PATENT CLAIMS. These Claims are published in the SCIENTIFIC AMERICAN in advance of all other papers.

Mechanics, Inventors, Engineers, Chemists, Manufacturers, Agriculturists, and People in every profession of life, will find the SCIENTIFIC AMERICAN to be of great value in their respective callings. Its counsels and suggestions will save them Hundreds of Dollars annually, besides affording them a continual source of knowledge, the experience of which is beyond pecuniary estimate. Much might be added in this Prospectus, to prove that the SCIENTIFIC AMERICAN is a publication which every Inventor, Mechanic, Artisan, and Engineer in the United States should patronize; but the publication is so thoroughly known throughout the country, that we refrain from occupying further space.

TERMS:—\$2 a year; \$1 for half a year, Southern, Western, Canada Money, or Post Office Stamps taken at their par value for subscriptions. Letters should be directed (invariably post-paid) to

MUNN & CO.,

128 Fulton street, New York

CLUB RATES.

Five Copies for Six Months, - - -	\$4
Ten Copies for Six Months, - - -	\$8
Ten Copies for Twelve Months, - - -	\$15
Fifteen Copies for Twelve Months, - - -	\$22
Twenty Copies for Twelve Months, - - -	\$28

For List of splendid CASH PRIZES, payable January 1st, 1856, see Advertisement page.