

# Scientific American.

THE ADVOCATE OF INDUSTRY, AND JOURNAL OF SCIENTIFIC, MECHANICAL AND OTHER IMPROVEMENTS.

Vol. 3.

New York, October 16, 1847.

No. 4.

## THE SCIENTIFIC AMERICAN:

PUBLISHED WEEKLY  
At 128 Fulton Street, New York (Sun Building,) and  
13 Court Street, Boston, Mass.

By Munn & Company.

The Principal Office being at New York.

TERMS:—\$2 a year—\$1 in advance, and  
the remainder in 6 months.

See Advertisement on last page.

## Poetry.

### MOVE ON.

BY GOODWIN BARMBY.

All the stars in heaven are moving,  
Ever round the bright spheres roving;  
Twinkling, beaming, raying, shining,  
Blackest night with darkest lining;  
Aye revolving thro' the years,  
Playing music of the spheres,  
Like the the Eastern star of old  
Moving toward the shepherd's fold;  
Where the wise men (grace to meet them!)  
Found the babe of Bethlehem.  
God is in each moving star:  
God drives on the Pleiad car;  
Let his will on earth be done  
As in heaven the stars move on—  
Move on!—Keep moving!  
Progress is the law of loving.

All the waves of sea are flowing,  
As the winds of heaven are blowing;  
With a gentle, beam-like quiver,  
Flows the streamlet to the river;  
With a stronger waved commotion,  
Flows the river to the ocean;  
While sea's billows evermore  
Flow and gain upon the shore—  
Wave on wave, in bright spray leaping—  
Like endeavors never sleeping;  
While the pool which moveth never,  
Grows a stagnant bog forever—  
White-gilled die its tenant tench,  
Green its waters, foul its stench,  
Wildering marsh-fires o'er it run,  
While still flows the river on—  
Move on!—Keep moving!  
Progress is the law of loving.

Thus within the skies and ocean,  
Life is married into motion;  
Stars revolve and rivers flow,  
And earth! what said Galileo!  
When in dungeon damps lying,  
Faint and tortured, hardly dying,  
'Tho' for truth, with honest pride,  
Yet "it moves! it moves!" he cried.  
And the world! its life is motion,  
As with stars, and as with ocean;  
It is moving, it is growing,  
All its tides are onward flowing;  
The hand is moving to the loaf,  
The eye is moving to the roof,  
The mind is moving to the book.  
The soul lives on in moving look,  
The hand is moving to the sword.  
The heart is moving toward the Lord!  
Move on!—Keep moving!  
Progress is the law of loving.

### A Curious Flower.

A singular phenomenon, says a French paper, has shown itself in a greenhouse at Lyons. At the time when all the growers of camellias, roses, dahlias, &c., are puzzling themselves to get the blue color, the only shade which nature has refused to these kind of plants, chance has thrown a shade of azure blue upon the petals of flowers produced by one single branch of a camellia root of the species *ambricala rubra*. This plant belongs to M. Dagene. The interior petal of the flowers are of a delicate red, the superior are white, and both are united with blue. The flower thus unites three additional colors.

## SMITH'S ROTARY ENGINE—Perspective View.

Figure 1.

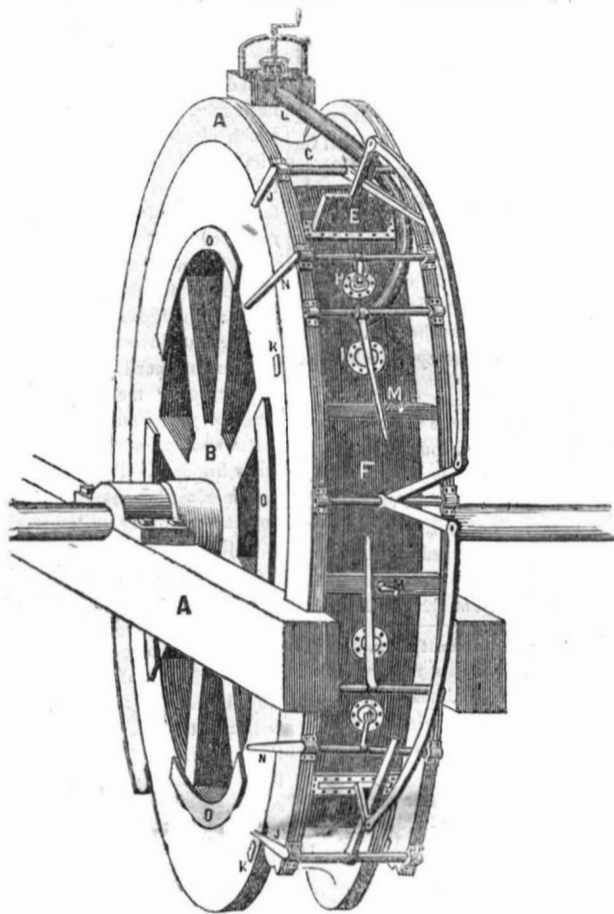

It would appear to most minds that rotary motion is superior to all kinds of motion for propelling machinery, hence the Rotary Steam Engine has occupied the attention of some of the greatest of men. James Watt was the first inventor of the rotary engine, but he found that the one which he first constructed and for which he obtained a patent, was far inferior to his parallel engine; he therefore laid it aside and devoted no more time or attention to the subject. Since his day, numerous rotary engine inventors have appeared in the field, and as early as 1796 Mr. Cook, of Dublin, secured a patent for one different to Watts' and which operated very well, but not equal to the reciprocating engines made at that period in England; it was therefore unable to compete in the market and was laid aside. We believe

For Figure 2, and description, see page 28.

### Napoleon's Poison.

From the time of Napoleon's retreat from Russia, he constantly carried round his neck in a little silken bag, a poisonous powder which his physician had prepared by his express order. On one occasion, when the sun of fortune was about to set on him, he had recourse to this chosen antidote. "I hesitated no longer," said Napoleon, "but leaping from my bed, mixed the poison in a little water, and drank it with a sort of happiness. But time had taken away its strength; fearful pains drew forth some groans from me; they were heard, and medical assistance arrived. It was not Heaven's will that I should die so soon—St. Helena was in my destiny."

### Hints About Food.

Roast meat contains nearly double the nourishment of boiled, but boiled meat is better adapted to weak digestion. Frying is one of the very worst methods of dressing food, as broiling is one of the best. Baked meat has a strong flavour, is deprived of some of its nutritious qualities, and is difficult of digestion. Spices, sauces, and melted butter, should never be used by the invalid, and in health they are not required.—*Kitton's Practical Medicine.*

that we have seen more than forty different Rotaries, but none that we could say was equal to the horizontal or reciprocating engines as now built. Yet for all this, some lucky inventor may arrive at the conclusion, of making a rotary engine to supersede in compactness and economy all others in use. We are, therefore, always glad and ready to present any new ideas on the subject that inventors may have arranged into a system.

DESCRIPTION.—A, cast iron frame. B, wheel. C, groove. E, drop or gate. F, concave. H, pappet valve, and steam passage into the groove C. I, escape valve. J, reflecting lever. K, cog. L, throttle valve. M, adjusting screw. N, reflecting lever, to let the steam into the groove C. O, projection to raise the lever N.

### To Ascertain the Age of a Horse.

Every horse has six teeth above and below; before three years old he sheds his middle ones; at three he sheds one more on each side of the central teeth; at four he sheds the two corner and last of the fore teeth. Between four and five the horse cuts his under tusks, at five he will cut his upper tusks, at which time his mouth will be complete. At six the groves and hollows fill up a little; at seven the groves will be well nigh filled up, except the corner teeth, leaving little brown spots where the dark brown hollows formerly were. At eight the whole of the hollows and grooves are filled up. At nine there is seen a very small bill to the outside corner teeth: the point of the tusk is worn off, and the part that was concave begins to fill up and become rounding; the squares of the central teeth begin to disappear, and the gums leave them small and narrow at the top.

A lady riding a few days since on horseback, through one of the Boston streets was stared at particularly hard, because she sported a pair of nice, clean, snowy-white pantalletes—with ruffled straps! We have heard of ruffled shirts, ruffled collars, ruffled tempers, but never before of ruffled straps.

## RAIL ROAD NEWS.

There are 147 Railroads in the United States measuring 5,392 miles, now finishing and in use. The first Railroad ever built in the United States was that at Quincy, Mass., 4 miles long, finished in 1827; the second was the Mauch Chunk Road, Pennsylvania, 5 miles long, having a track but 3 feet 6 inches wide. The highest grade of a travelled road (80 feet in a mile) is on the Springfield and Albany where it crosses the Green Mountain chain. That from Cleveland, Ohio, to the quarries, has a grade of 264 feet to the mile.

### Hudson River Railroad.

The contracts for making this road through that part of the Highlands which has been by many considered so difficult and expensive, have all been made at a much less cost than was anticipated. The whole extent of tunneling in this difficult portion of the road is only 1336 feet, viz. 100 feet of tunnel on the Pegg's Island section, below Peekskill; 100 feet at Anthony's Nose; 486 feet at Philips's opposite West Point; 450 ft. at Breakneck Hill.

### Vermont and Massachusetts Railroad.

At the late meeting of the stockholders of this company, held at Baldwinsville, it was unanimously voted to put the residue of the road from Northfield to Brattleboro' forthwith under contract and to complete the same without delay, and unite this company with the company chartered in the state of Vermont.

### Great Western Railway.

When this splendid road is finished and a bridge thrown across the Niagara river, the time required to travel from Detroit to the Falls will only be ten hours. One hundred and seventy miles of it were put under contract last month.

### The Broad Gauge.

The articles of agreement between the St. Lawrence and Atlantic Railroad Companies, stipulate that the track shall be 5 feet 6 inches wide in the clear, between the rails.

### New Broad Gauge Line in England.

A bill is about to be brought into Parliament for a new broad gauge line, connecting the Western Railway with Dudley, Worcester and the mineral districts of Wales.

### Greenock Railway.

Sixty thousand passengers were carried along this road in two days, without a single accident, although 1600 passengers were in every train. All went to see the Queen but had to pay their own passage.

### Wood's Patent.

It will be remembered by our readers that a decision was had not long since in the United States Court, in favor of this important patent covering, as it does, all cast iron ploughs.—We understand that the heirs are now making settlements in the State of Connecticut for damages upon the patent.

### Perpetual Motion.

A Mr. J. Hutt, of Hincley, England, frame work knitter, states that after nineteen years intent study, he has discovered perpetual motion. His machine, he says, is capable of working any mill, or turning any motive power, without the aid of steam, water, or air, having an inherent power of its own—an arm which never tires. A gentleman in Brooklyn N. Y., claims to have discovered a similar power some years since. We are, however, sceptical on this subject of perpetual motive power.

### A Sagacious Dog.

The ear of a dog belonging to a man near Sturbridge was severely hurt, and the animal was consequently taken to a chemist's shop where the wound was dressed. During three days the dog was regularly conducted to the shop by his master, but on the fourth morning he found his way there alone, leaped on the counter, and waited till his ear was dressed. This visit he repeated every morning until his ear was wholly healed.

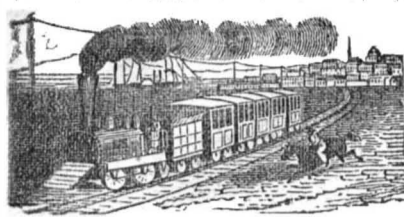

The Great Fair of the American Institute.

The twentieth annual Fair of the American Institute has been distinguished for a great variety of new, beautiful and useful inventions. It is not possible to notice all the different articles out of a mass of nearly two thousand and indeed it would be out of place, as the same kind of many articles have been exhibited often before. Yet even to the new and useful machines, it is not possible to pay that tribute of notice which we should be happy to do and which we are glad we are not able to do, because of the great number of such productions—a reason which all will rejoice to see set forth as the inventive turn of our people may be said to leave description far behind.

The Agricultural department is well represented by a goodly array of choice implements among which we picked out the unique plough, a description of which is on another page.

The manufacturing department is well represented by some splendid cotton and woolen cloths. The mechanical department on which all the rest depend was never surpassed nor equalled for useful inventions among which we noticed Haviland and Tuttle's patent centre vent pressure water wheel—a model and a beautiful one. It is of great power and its facility of adaptation is not surpassed by any other wheel now in use. They are manufactured at the Fulton Foundry in this city, and also by E. Tuttle, No. 4 Broadway, South Boston. We also noticed the Fire and Burglar Alarm, the invention of Messrs. Tomlinson and Hopkins, of Brookfield, Connecticut.—The principle of the fire alarm is the expansion of metals communicating by a wire to an alarm clock and by wires from doors and windows to the clock. The burglar alarm is a great and a most useful invention and it should be put up in every house. No invention is more needed than this, and we hope it will be generally adopted in this city. A portable Sun Dial is another beautiful invention by Mr. W. Jones, 275 Spring st., of this city.—We have seen all these things with our eyes, and refer not by number of the catalogue.—We believe that Mr. Jones wishes to dispose of the patent right of his astral chronometer, as well as his dial, for which he has received a medal and diploma. The chronometer of Mr. A. T. Cochrane of 288 Greenwich street of this city, with an entire new escapement constructed by himself is a beautiful and good invention.

There were a number of cases of jewelry, such as gold pens, &c. which we shall notice according to their merits at some other time.

Benson's new Rotary Steam Engine patented last July is a curious but about the best rotary we have seen is of 30 horse power and works wonderfully with only nine pounds of steam on the lever. It takes up as little room as a ten horse power parallel engine. It is worked by the steam acting on four pistons in a ten inch cylinder working at an angle as they rotate on two large cog wheels. The pistons are worked the same as the pistons of any other engine and the crank ends are balls rolling in sockets in a disc—hence it is only a semi rotary engine.

Lewis Kirk's Steam Hammer, is another beautiful invention. At the command of the engineer it is a lion or a lamb.

Gillman's Self-feeding Card Press, is just the thing we have spent many a thought upon in vain. It surpasses all others that we have seen. Wells and Webb are the agents in this city.

Chase's Card Spinner, is another invention. It covers a cotton thread with wool right from the cards. Kane and Leonard's Spindle Spinner, is another good and unique invention. It was invented at Mattewan, and combines the qualities of the throstle and mule frames, for after the rove goes through the drawing roller

it spins over the point of the bobbin spindle dispensing with the flier entirely, being guided on to the bobbin by a traveller whirling on the spindle collar.

Munsell's Morticing Machine, is a good invention, it can mortice round a carriage hub in short order.

Mr. J. Echols's Safety Union Water Gauge, is a most valuable invention and received considerable commendation from some scientific men.

The best Gingham we noticed were those from Marshall's works, Troy. They are very substantial, and must win favor with those who buy fabrics that will wear well. These are Cotton Cassimeres, from New York Mills, Whitestown, that challenge admiration.

There were a great number of other useful and beautiful inventions, which we shall be happy to notice again.

#### A Crooked Fence.

There is a piece of fence in Indiana, made of pine rails so crooked, that every time a pig attempts to crawl through it he comes out on the same side from which he starts.—So says one, who saw it. We think the man must have been wonderfully cross-eyed, when he looked at it.

#### Destruction of Large Mills.

The extensive Gallego Flouring Mills in Richmond, Va., were entirely destroyed by fire on Sunday morning, about 5 o'clock. The loss was very heavy. The mills were owned by Messrs. Warwick & Burksdale. A large number of other houses were destroyed. The whole loss was estimated at \$250,000.

#### Vaccination and Small Pox.

M. Van Berchem, from his researches on vaccination and small pox, has come to the conclusion that among the vaccinated, the older the individual the greater is the liability to an attack of the small pox. Among the unvaccinated it is the reverse, for the younger the person the more he is liable to an attack of small pox.

#### Civil War of Turkey.

Information from Constantinople has been officially communicated, of an intended blockade by the Sublime Porte of a part of the coast of Albania, from Previsa to the port of Durazza, in consequence of an insurrection in that province.

#### Franklin Institute.

The annual exhibition of this Institute will be opened at the Museum Building Ninth and George sts. Philadelphia, on the 19th inst. and from the extensive preparations being made we have no doubt but that it will prove highly attractive to its visitors and creditable to the American mechanics.

#### Indiana.

The Wabash river and its tributaries water nearly two thirds of all the counties of Indiana! Of eighty-eight counties in this State no less than fifty-five are watered by the Wabash river!

#### A Tough One.

The Mobile Advertiser states that a negro weighing 170 pounds fell from the third story of a house in that city, and struck on the pavement without breaking a single bone, or even, the skin on any part of his body.

#### To Cure a Cough.

The editor of the Baltimore Farmer says, the best remedy he ever tried in his family for a cough or cold, is a decoction of the leaves of the pine tree, sweetened with loaf sugar to be freely drank warm when going to bed and cold throughout the day.

#### Sugar.

It is estimated that this year's Sugar crop, in Louisiana, will exceed last year's 50,000 hogsheads.

#### Etiquette.

When the great Duke of Argyle was one night at a theatre, in a side box, a person entered the same box in boots and spurs. The Duke arose from his seat, and with great ceremony expressed his thanks to the stranger, who somewhat confused, desired to know for what reason he received those thanks, when the Duke gravely replied—'for not bringing your horse with you sir.'

#### Facts for the Public—The Scientific American.

A gentleman called at our office a few days since to desire us not to give notice of his inventions until he called and requested us to do so, we asked him why he made that request? Says he, "since you published an engraving of an improvement that I made in constructing certain parts of machinery in Saw Mills, I have been so troubled with applications to sell the patent rights, and have had so many orders to fill, that I cannot properly attend to all the business forced upon me by your notice, which very much perplexes me." We asked the gentleman's pardon for the trouble we had caused him, and promised never to discommode him in like manner again, although he was not actually so much displeased with us for that agreeable kind of trouble but what he insisted upon our taking ten dollars is (which we declined) as a fee for some of the benefits we had actually rendered him.

To Inventors we would say, does this circumstance not shew unto the world, what a great advantage can be secured to you by publishing your inventions in our paper? Surely a paper that has 11,000 of a weekly circulation is a far better medium of spreading knowledge of your inventions throughout our continent and the world, than one that has but as many hundred. Remember that the Scientific American has the largest circulation of any mechanical paper in the world and a larger one than all the others published in America combined. Remember also that our prices for engraving and inserting notices of inventions are no higher than those of other papers of not one-eighth the circulation and whatever amount of money sent us has always been used, and shall be, for the purposes sent, and that all things will be managed for the interest of inventors as well as though they were here to attend to the business themselves.

In connexion with our Patent agency in this City, we have an agency in Washington and for a suitable fee for examination, any information will be promptly and minutely secured to all those who may desire it: in giving advice regarding the utility of inventions, we have always been guided by an honest regard for the welfare of inventors and when we have thought that some improvement or invention desired to be patented by an inventor, would be of no benefit to him, we have always candidly advised him not to expend his money in vain. Such has been the course which we have pursued, and such it always shall be.

#### Consumption of Sugar.

In England the present consumption of Sugar may be taken at 2,000,000 tons per annum, being at the rate of 21 lbs. per head of the population, while in France it is only 8 lbs. per head.

The British Government have established a semi-monthly mail to the copper mines on Lake Superior on the north side of the lake. The conveyance leaves Toronto on 13th and 28th of each month, and takes passengers in 60 hours to Sault Ste. Marie, by way of Lake Simcoe, to Sturgeon Bay on Lake Huron, and thence to Owen's Sound, and then to the Sault. This is 450 miles nearer than by Lake Erie.

Midshipman Pollock, who fired his pistol at the thigh of Mr. Jewett of the Buffalo Commercial, and would probably have broken his leg at least had not the ball been stopped by Mr. J.'s wallet, has been convicted on a second trial and sentenced to five years' imprisonment at Auburn.

A Cincinnati paper says that Kentucky has 26 millions of acres of land estimated to be worth 250 millions of dollars.

Alum water, repeatedly applied is one of the most effectual remedies known for that troublesome winter complaint called "chilblains."

An English paper speaks of a recent importation of 11 barrels shoe-pegs from Baltimore, 337 wheel-spokes from Sidney.

The narrowest part of the Atlantic is more than two miles deep. In other parts it is one and a half miles.

#### The Lasso.

In a night skirmish the lasso is a dangerous article. A Californian will lasso a man and drag him off his horse, and choke him in one minute; and without getting off his horse he will take his lasso off the neck of his vanquished foe, and in two minutes will be prepared for another. I have seen a man do this when fighting the wild Indians; and a man pursued by two others with a brace of pistols each, would stand a better chance of saving his life, than a man pursued by one Californian within lassoing distance; because the party pursued by those with the pistols might possibly dodge and destroy the aim of pursuers; but he who should be pursued by the Californian with his lasso, would have no means to escape, because the lasso, when thrown at anything that is running, is as true in the hands of a Californian, as a rifle ball from a good marksman's steady aim.

We learn that a bed of coal has been discovered in the town of Ridgefield, Ct., and that measures are in progress for working it. A gentleman of experience has contracted with the proprietor of the land for the privilege, and is now in the pursuit of proper hands and means for commencing operations.

A colossal bust of Juno in perfect preservation was lately discovered at Tunis by the workmen employed in excavating stone from the site of an ancient harbor. The Bey of Tunis has presented this exquisite work to M. Delaporte, grant of the general consulship of France at Tunis.

When a London Cockney, who had always risen at midday, had been induced, on a water party, to see a sunrise, he exclaimed, when the sun was above the horizon and people were turning away, "is that all? I thought it went up like a rocket!"

A stone weighing a ton and a half, and a derick used for hoisting it, fell from the wall of the new church, corner of Beach street, Boston, Saturday forenoon, a distance of some 70 feet, fortunately without injuring any one, though several persons were in imminent danger.

A Greek maid being asked what fortune she had for her husband, answered—"I will bring him what is more valuable than any treasure—a heart unspotted and virtue without a stain, which is all that descended to me from my parents." How beautifully expressed.

Mount Lafayette, one of the White Mountains in New Hampshire, was covered with snow on the 16th ult.

Applications have been made to the Grand Lodge of the United States for charters of Odd Fellows Lodges in Oregon, Honolulu, Oahu and the Hawaiian Islands.

The human brain is the twenty-eighth of the body, but the brain of a horse but a four-hundredth.

The name of the democratic candidate for governor of Georgia, is George Washington Napoleon Bonaparte Towns.

The waters of the Red sea appear to be thirty-two feet higher than the Mediterranean—and the Gulf of Mexico is twenty-eight feet lower than the Pacific.

The sea is to the land, in round millions of square miles as one-hundred and sixty to forty, or as four to one.

The North Adams Railroad through the swamp at Lanesboro, sunk again on Monday week for the third or fourth time.

A Telescopic Comet was discovered by a lady of Nantucket (says the Boston Transcript on the morning of the 1st inst., in the Constellation Cepheus. It is now visible to the naked eye.

The English committee on the China trade states that the amount of manufactured goods imported by China from the United States is about £170,000, say \$800,000.

The population of Jersey City is 5,862, being an increase of 444 in one year.



**The Divisibility of Matter.**

At the first step we take in geological inquiry, says the Rev. Dr. Buckland, we are struck with the immense period of time which the phenomena presented to our view must have required for their production, and the incessant changes which appear to have been going on in the natural world; but we must remember that time and change are great, only in reference to the faculties of the being who notes them. The insect of an hour contrasting its own ephemeral existence with the flowers on which it rests, would attribute an unchanging durability to the most evanescent of vegetable forms, while the flowers, the trees, and the forest would ascribe an endless duration to the soil on which they grow; and thus uninstructed man comparing his own brief earthly existence with the solid frame work of the frame work he inhabits, deems the hills and mountains around him coeval with the globe itself. But with the enlargement and cultivation of his mental powers, he takes a more just, comprehensive and enlightened view of the wonderful scheme of creation, and while in his ignorance he imagined that the duration of the globe was to be measured by his own brief span, and arrogantly deemed himself alone the object of the Almighty's care, and that all things were created for his pleasure and necessities, he now feels his independence, entertains more correct ideas of the mercy, wisdom, and goodness of his creator; and while exercising his high privilege of being alone capable of contemplating and understanding the wonders of the natural world, he learns the most important lessons—to doubt the evidence of his own senses until confirmed by patient and confirmed investigations.

"Where is the dust that has not been alive." The remains of organic existence, found in the median and other tertiaries, conduct us from the colossal and imposing to the minute and microscopic; for beds occur entirely composed of the fossil relics of animalcules—those infinitesimal forms now present in our lakes, rivers, and streams, invisible to the unassisted sight, whose perfect organization places them among the wonders of the creation. They were formerly supposed to be little more than mere particles of matter endowed with vitality; but Ehrenberg has discovered in them an apparatus of muscles, intestines, teeth, different kinds of glands, eyes, nerves and organs of reproduction. Yet some of the smallest are not more than the 24,000th of an inch in diameter, the thickness of the skin of their stomachs not more than the 50,000,000th part of an inch a single drop of water having been estimated actually to contain 50,000,000 individuals. Not less astonishing is their power of multiplication, an individual of one species increasing in ten days to 1,000,000, on the eleventh day to 4,000,000 and on the twelfth day to 16,000,000: while, of another kind, Ehrenberg states that one individual is capable of becoming, in four days, 170,000,000,000! To this distinguished naturalist we are indebted for the development of the fact that ages ago our world was rife with these minute organisms, belonging to a great number of species, whose mineralized skeletons actually constitute nearly the whole mass of the same tertiary soils and rocks several feet in thickness, and extending over areas of many acres. Such is the *Polirschiefer*, or polishing slate of Bilin in Bohemia, which occupies a surface of great extent, probably the site of an ancient lake, and forms slaty strata of fourteen feet in thickness, almost wholly composed of the silicified shields of animalcules. The size of a single one, forming the polishing slate, "amounts upon an average, and in the greatest part, to one-two-hundred-and-eighty-eighth of a line, which equals one-sixth of the thickness of a human hair, reckoning its average size at one-forty-eighth of a line.

The globule of the human blood, considered at one-three hundredth is not much smaller. The blood globules of a frog are twice as large as one of these animalcules. As the *Polirschiefer* of Belin is slaty, but without cavities, these animalcules lie closely compressed. In round numbers, about 23,000,000 would make up a cubic line, and would, in fact, be contained in it. There are 1728 cu-

bic lines in a cubic inch; and therefore a cubic inch would contain, on an average, about 51,000,000,000 of these animals. On weighing a cubic inch of this mass, I found it to be 220 grains. Of the 41,000,000,000 of animals 178,000,000 go to a grain; or the silicious shield of each animalcule weighs about one-hundred-and-eighty-seven-millionth part of a grain." Such is the statement of Ehrenberg, which naturally suggests to the reflection of the French philosopher, that if the Almighty is great in great things, he is still more so in those which are minute; and furnishes additional data for the well known moral argument of the theologian, derived from a comparison of the telescope and microscope:—"The one led me to see a system in every star; the other leads me to see a world in every atom. The one taught me that this almighty globe, with the whole burden of its people, and of its countries, is but a grain of sand on the high field of immensity. The other teaches me, that every grain of sand may harbor within it the tribes and families of a busy population. The one told me of the insignificance of the world I tread upon. The other redeems it from all insignificance.

**Plumbe's and Whitney's Projects for A Rail Road to the Pacific.**

Plumbe's first application to Congress was in 1838, when an appropriation was made, and the survey commenced. His plan is to divide the grants (of land) into twenty millions of shares, at \$5 each; and every body afforded the opportunity of securing one, on paying an instalment of 25 cents. Directors to consist of one for District of Columbia, and one for each State or Territory.

Whitney first appeared before Congress in 1845, asking for a grant, equivalent, at minimum price, to about one hundred and twenty millions of dollars, to be made to himself, he to be the sole manager of the whole work, and to own all the land that remained after completion of the Road; the Road to be his for twenty years; and on payment then of 16 cents per acre, for the land, the Road to be his forever.

**The Yankees.**

You can always tell a Yankee by the jack-knife in his hand, or the cigar in his mouth. The Yankees are curious characters. To-day they are swapping horses, and to-morrow building railroads; this hour in the gutter and the next seated in a palace. Their energy knows no bounds. This month you may find a Yankee on the waters of the Penobscot heart and soul engaged in the logging business; a quarter of a year hence you will hear of him navigating the Ohio. Let a year pass, and you may learn of him in Constantinople.

Change appears to be written in the face of a Yankee. He is never contented. If he is boot-black or a clam-digger, ten to one that you will find him at the bar or in the pulpit. If educated for the ministry, he may be found teaching at some conspicuous corner. If his father puts him to a mechanical trade, he will not be contented unless he sets up for himself in some mercantile business. To-day he is one thing and to-morrow another. He will dig gardens, saw wood, teach school, preach, or even edit a newspaper, if necessary for a support; but he will not be idle.

**A Lucky Escape: Thrillingly Thrilling.**

Last week while one of the workmen was engaged in cleaning the ball on the State House steeple, the scaffolding on which he stood gave way. The crowd on Chestnut street who were watching the whole operation, were speechless. Down—down he came—but just midway, with great presence of mind he pulled out his knife and stuck it in one of the pillars of the belfry with sufficient force to sustain himself by it, until he was rescued from his perilous situation.

Barnum has written for the case knife, which is made of a very tough piece of india rubber.

A Boston company are negotiating for the falls in Dixfield, on the Androscoggin river, for manufacturing purposes. The water powers are not perhaps surpassed in the State, and it is said the company intending to improve it can command a capital of two million dollars.

**The Cricket Steamboat.**

Owing to the great sensation created by the explosion of a steamboat called the Cricket, on the river Thames at London, a number have made enquiries regarding her engines, &c., as explosions have not been as common in England as in our own country. For the last few years, however, our steamboats have secured for themselves a superior character, for while they are the fastest in the world none are more safe or more successful.

The Cricket was one of a line of boats belonging to the London Penny Steam Boat Company. She was fitted with engines built by Joice & Co. of the Greenwich Iron works, and had engines of Woolfe's double cylinder kind, or oscillating engines. The steam was used at a higher pressure than in the ordinary condensing engines and was first conveyed to a small cylinder, when after having exerted its direct pressure upon the piston, it passed to a larger one where it acted expansively in conjunction with the vacuum in the condenser, in a degree dependent on the ratio capacity of the two. The expansion of the steam was carried on gradually and these engines were considered very superior, as they only consumed 4½ lbs. of coal per horse power in an hour. Her average speed was 14 miles an hour and her horse power 66,000 lbs. register, double the common register. Her slide valves were of the three ported kind worked by a rocking shaft placed in the bearings of the cylinder covers. It is supposed that the cause of the explosion was some defect in the operation of the valve connecting the condensing and high pressure cylinders.

**English Quarter.**

Many persons do not clearly comprehend the term "Quarter" as applied to grain in England. It is this: A ton is 2,240 lbs., a quarter of that, is 560 lbs., and this is the weight of the British or Imperial quarter of wheat. The U. S. Standard allow 60 lbs., to the bushel, the British 80 lbs., thus 8 x 70 = 560. A bushel of wheat in the United States is equal to 6-7ths of an English bushel, and a British quarter of wheat is equal to 9½ U. S. bushels of 60 lbs. each.

England's war debt is nearly 800 million pounds sterling! Her former wars now cost the people nearly thirty millions annually besides the current cost of the army and navy.

**A Rare House.**

Mr. Barnum's House which seems to be a compound of Moorish, Gothic and Turkish architecture, attracts a great many visitors. An English gentleman who was here lately, declared that he had come 3,000 miles for the purpose of taking a look at the thing. Probably he was an artist, employed for a London publication. We believe there is nothing in England, or indeed in Christendom, resembling this edifice, excepting the Brighton Pavilion, built by George IV. The cost of the structure and grounds will be some \$60,000.

**Grace and Beauty.**

Beauty; says Lord Kaimes, is a dangerous property, tending to corrupt the mind of a wife, though it soon loses its influence over the husband. A figure agreeable and engaging which inspires affection without the ebriety of love, is a much safer choice. The graces lose not their influence like beauty. At the end of thirty years, a virtuous woman, who makes an agreeable comfortable companion, charms her husband perhaps more than at first. The comparison of love to fire holds good in one respect, that the fiercer it burns the sooner it is extinguished.

**Advertisements.**

A curious example of the ingenuity of the advertising spirit is given by a French Paper. A mercantile house at Berlin has proposed to the various railway companies of Germany to supply all their carriages with silk blinds gratuitously. They simply propose to reserve to themselves the right of changing the blinds as often as they may please; and they require the companies to engage themselves not to accept during fifty years, either for money or gratuitously, any blinds but theirs. Their object is to cover the blinds with advertisements.

A lady fortune-teller of Wilmington, Del., has retired from business with a handsome fortune.

**Popping the Question.**

Some writer who takes the Sobriquet of *Jeremy Short*, thus gives his experience as this subject. Jeremy has been "about," and is "one of 'em," decidedly:

"It will pop itself. It's nonsense thus lending young folks a helping hand—take my word for it, all they wish is to be left alone—and if there be any confounded youngsters about, let them be put in bed or drowned it don't matter a fig which. If lovers hav'nt no tongues, hav'nt they eyes, egad! and where is the simpleton that can't tell whether a girl loves him, without a word on her part? No one adores modesty more than I do, but the most delicate angel of them all won't disguise her little heart when you're alone with her. A blush a sigh, a studied avoidance of you in company, and a low, thrilling trembling of the voice at times, when no one else is by, tell more than the smiles of a thousand coquettes. Ah! you need'nt, Amy, shake your head, you'll know soon enough—but if you fall in love, as you will, my word on it, the very echo of one footstep will make your heart flutter like a frightened bird."

**Depth of the Ocean.**

At the annual meeting the association of Am Geologists in Boston, Commander Wilkes, U. S. N., made a communication upon the subject of the depth and saltness of the ocean. The maximum depth has never been attained. Capt. Ross sounded 4600 fathoms, about 37,000 feet, and got no bottom. There are great difficulties attending deep soundings. Experiments show that the great valleys of our ocean run at right angles to the ranges near our coast. The basins of the Southern hemisphere dip and rise alternately from the equator towards the pole, causing very unequal depths of water.

Experiments were made by Captain Wilkes upon the penetration of solar light. A pot painted white was let down into the water, and the point of invisibility marked—upon taking it out, the point of visibility marked, and the two were found to vary but a fathom or two. In water at 36 degrees the pot disappeared at six fathoms—in the Gulf Stream, at twenty-seven fathoms—just outside of it, at twenty-three fathoms.

**A Relic.**

A medal struck in honor of Mr. Pitt, without date, which was found about six years since in the Baptist burial ground in Gold street, was presented on Tuesday evening to the Historical Society of this city, by a member. On one side of this interesting relic is a portrait of Mr. Pitt, with the name of "Guilielmus Pitt" inscribed thereon, and on the other the following words—"The man who having saved the parent, pleaded with success for her children."

**Weight of Grain.**

The following table, exhibiting the number of pounds to the bushel, of the different articles enumerated, may be of service to many.

Wheat, 60; beans 60; cloverseed, 60; potatoes, 40, corn 56; buckwheat seed, 52; salt 50; barley, 48; castor oil beans, 56; hempseed, 44; timothy seed, 56; oats, 24; bran 20; blue grass seed, 14; peaches (dried), 24; apples (dried), 22; stone coal, 70.

**Mechanics for the War.**

Forty-three mechanics, composed of blacksmiths, carpenters, saddlers, armorers &c. arrived in this city from Pittsburg, on Saturday. They are in the employment of the government, and receive about \$45 per month, and one ration per day. They are a fine looking intelligent set of men, and we are gratified that out of the evil of war comes the good of giving them employment and high wages. They leave for their destination either to-day or to-morrow.—*Cincinnati Paper.*

In a Boston paper we find an account of the doings of the meeting of the Naturalists there, which say that it has been long known that two rays of light may be so thrown on each other as to produce darkness. Prof. Henry showed that two rays of heat may be so combined as to produce cold.

Most mountains present their precipitous faces to the sea and their slopes to the land.

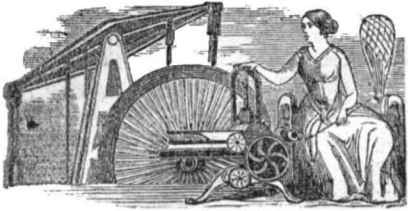

## New Inventions.

### Brewster's Reversing Plough.

We noticed a working model of Mr. Iram Brewster's reversing side hill plough at the Fair of the American Institute, and it gave us great pleasure to perceive that it was most favorably viewed by practical farmers. We noticed this invention some time ago in the *Scientific American*, Vol. 2, and since that period, Mr. Brewster has experimented with his plough, and found it to be a great improvement over any kind of side hill plough now in use. Mr. Brewster uses a strong spiral spring for clinching and unclenching the mould board, so that with the utmost ease it can be reversed and plough backwards. We shall be able at some future period to give an engraving of this useful and ingenious plough. Measures are in progress to secure a patent.

### Capstan Pump.

Mr. James F. Andrews, of Boston, has invented a curious pump for nautical purposes, by which a capstan is made to be a pump and to be used as a capstan alone, or both at the same time, without any change of motion. It has the appearance of the capstans now in general use in common ships—possessing however, either the same power, or eight times as much, by a reversal of power. The pumps, four in number, are worked by the capstan. The motion, or stroke of the pump, is obtained by four inclined planes, attached to the circumference of a drum below, but connected with the capstan. The great utility of this invention is obvious upon philosophical principles, when it is considered that it embraces the three mechanical powers of the lever, the wheel, axle and inclined plane combined; working with greater ease and equal velocity four pumps at once—of greater capacity than those now in common use by the lever alone. With this invention, it is said, two or three men may without fatigue discharge from a vessel not air tight, from 1500 to 2000 cubic feet of water per hour.

### Oscillating Window Shade Rollers.

Mr. George H. Marden, of Charlestown, Mass., has invented a new and beautiful method of suspending and operating window shades. The improvement consists in having small oscillating metallic blocks fastened on the ends of the roller and screwed into the window bead, fitting nicely, so that they will swing with the shade and allow the sash of the window to move freely up the full length of its plane, and also allow the shutters to close perfectly.

### Sheet Lead Machine.

Mr. John Robertson of Brooklyn, N. Y., has invented a new machine for making sheet lead, which can also be applied for making other soft metals into sheets. He uses a die of the size of the sheet to be made and by a peculiar manner of pressure on the surface the metal is made to rise in sheets. The die, we believe, is in a different chamber from the metal, and the lead is made to pass through a space in it. A patent has been secured for the invention.

### New Water Wheel.

A new horizontal water wheel has been invented by William Lamb, of Rome, Oneida Co., N. Y., whereby the water is introduced by a trunk forming part of another wheel, to give direction to the water. We have not yet been informed as to the advantage gained by this combination, if there can be any.

### Improvement in Propelling Screw.

Mr. James Montgomery, of Memphis, Tennessee, now in this city, has invented an outer rim to the Archimedeian screw for propelling vessels, whereby it is much strengthened and he has surrounded the whole with a casing which protects the screw from injury and secures a more perfect action.

### Twisting Withes.

Mr. Jonathan Swift, of Frankfort, Maine, has invented a new machine for twisting withes, whereby the process is shortened and a much better article made. He uses a kind of windlass for straining the fibres of the pole to be made into withes, and while the windlass is revolving and twisting the withes at one end, he uses pincer jaws for holding and securing the withes at the other end.

### Noiseless Wheel.

Among the numerous ingenious inventions of the present day is a noiseless wheel for carriages, patented by Mr. Andrew Smith, of England, galvanised iron and wire rope manufacturer. The silent properties of this wheel are not obtained at the expense of appearances, nor by any additions which detract from the elegant appearance of the vehicle. The

tire is composed of numerous layers of galvanised plate iron lapped together, and then re-galvanised in the mass, and which, when running over the stones, make no more noise than if running on a surface of lead. The nave or box of the wheel is lined with an elastic substance, which makes a perfect stuffing box, and thus prevents any noise from the axle; and on the whole must be an important addition to the comfort of omnibus and stage passengers.

### Propelling.

An Engineer in Glasgow has effected an invention by which vessels on rivers and canals can be propelled at about the same speed as steam carriages on railways, and at about half the cost.

The above we have taken from one of our London Exchanges. The nature of the invention is not described.

## SMITH'S ROTARY ENGINE--Vertical Sectional View.

Figure 2.

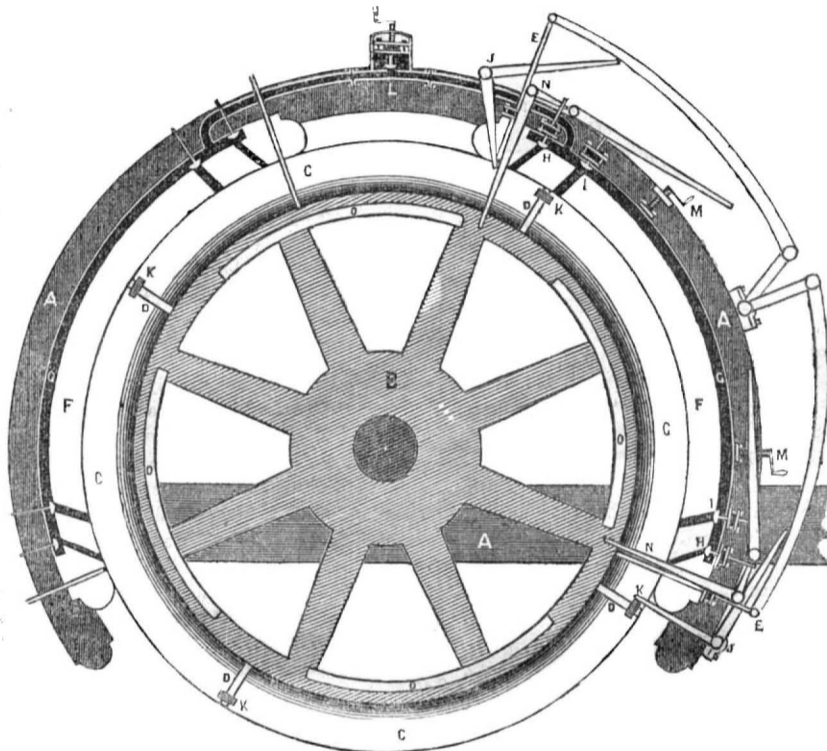

DESCRIPTION.—A, is the cast iron frame referred to in fig. 1. B, is the wheel, the spokes or arms of which will be observed to be something like those of a water wheel. C, is a groove in the outer surface of the wheel, and D, partitions in said groove. F, is a concave fitted to the outer surface of the wheel, and G, is a steam chest cast in the concave. H, is a pappet valve and steam passage into the groove. I, is an escape valve. J, is a reflecting lever to raise the drop valve or gate E, out of the groove C. K, is a cog to reflect the lever J. L, is a throttle valve and steam pipe, regulating the steam to the steam chest M, is an adjusting screw for the purpose of screwing up the concave, if it is ungeared by expansion. N, is another reflecting lever to raise the pappet valve H, and let the steam into the groove, and O, is a projection or cog, to raise the reflecting lever N.

OPERATION.—One of the partitions D, hav-

ing passed under the concave F, the drop E falls a little distance behind the partition D, leaving a small space into which the steam is now admitted through the passage H. The drop E, being stationary, the partition D, moves off, thereby giving motion to the wheel B.

The inventor of this Rotary Engine is Mr. G. Smith, of New Orleans, and we would observe, in extending his own description, that he proposes to use the steam expansively, and for that purpose he divides his wheel into four chambers, packed on the periphery and geared on each section as duplicates of the above valves, levers, &c. The whole steam power is therefore to be understood as applied to the edge of the wheel. His wheel is to be broad, cast and then grooved; to make it more solid and capable of being better packed. It is to be fitted in a frame and run on gudgeons like a water wheel.

### Bull's Stationary Chimney Top.

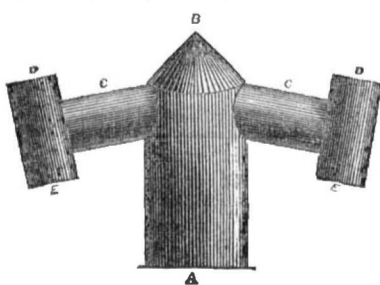

This chimney top is the invention of Mr. Thomas W. Bull, of this city, and after a fair trial of its capabilities, it has answered the purpose intended so well that the inventor considers himself fully justified in saying that it is the best chimney top ever invented. It is composed of five flues, which are all made of different pieces and joined together, or cast all in one piece of iron or clay. A, is the main draught tube which is set on the chimney, and B is a conical top. C C, are the bran-

horizontal draught tubes, or the ends of which are fastened perpendicular tubes, which have two openings each, D E. The merit claimed for this invention, is the impossibility of the chimney ever smoking by the smoke being blown down the chimney by the winds. If the smoke is blown down at D, it will pass out at E, or if by the strongest winds, it is driven back through C, it will pass over the top of the main flue A, as the conical top B is hollow, and pass out at the other side by the other flue C. These chimnies can be applied to steamboats and locomotives, by fixing a screen on the openings to keep back sparks, or having a screen on D, and the tube E coming down some distance to let the sparks fall into a receptacle. Further information regarding this chimney top, can be had by communicating with P. Naylor & Co., No. 13 Stone street, this city.

A block of copper ore from Pittsburgh, Pa., is being exhibited in Liverpool, which weighs nearly two tons.

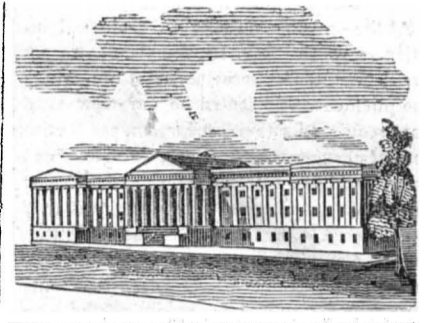

## LIST OF PATENTS

ISSUED FROM THE UNITED STATES PATENT OFFICE,

For the week ending Oct. 9th, 1847.

To John Y. Savage, of New York, for improvement in Chronometric Locks. Patented Oct. 9, 1847.

To Hiram Berdan, of Plymouth, Michigan, for improvement in Grain and Straw Separators. Patented Oct. 9, 1847.

To Horatio Ames, of Falls Village, Conn., for improvement in machinery for twisting and rolling iron, (for which a patent was granted in England to Geo. Wetherell, of New York, for the benefit of the aforesaid Horatio Ames, under the title of "Improvements in manufacturing or working iron for various useful purposes," which patent bears date the 29th day of July, 1837.) Patented Oct. 9, 1847.

To John T. Davy, of Troy, New York, for improvement in Cooking Stoves. Patented Oct. 9, 1847.

To Lewis Kirk, of Reading, Penn., for improvement in Jointed Pipes for Steam, &c.—Patented Oct. 9, 1847.

To Simon Broadmeadow, of New York, for improvement in furnaces for the manufacture of Steel. Patented Oct. 9, 1847.

To William McAdams, of Albany, New York, for improvement in ornamenting Book Covers. Patented Oct. 9, 1847.

To Frank Cheney, of Manchester, Conn., improvement in machinery for doubling, twisting and reeling thread. Patented Oct. 9, 1847.

## INVENTIONS AND CLAIMS.

### India Rubber Shoes.

Invented by Robert Story and Thomas Hopper, of New Brunswick, N. J. Patented 7th August, 1847. What they claim as their invention and secure by letters patent, is the attaching leather soles to metallic rubber shoes by means of a sole and heel of cloth prepared with metallic gum on the inside, for the purpose of adhering to the shoe in the process of curing in the heated chamber. And when cured they are ready for attaching the leather sole and heel as named in the specification.

### Water Wheels.

Invented by Horace Parsons, of Houston, Illinois. Patented August 7, 1847. What he claims as his invention and secures by letters patent, is the making the wheel with buckets torined with about their depth parallel with the axis of the wheel, and tangential to a circle smaller than the hub (or thereabouts) and the other half at an angle therewith, when this is combined with a scroll shute on one face for the admission of the water, and a retaining plate on the other provided with a hole for the discharge of the water opposite the end of the scroll.

### Improvement in making Scabbards.

Re-issue—to Francis Durand and Olesiphore Pacqueur, of Paris, France, for improvement in making Scabbards and other hollow articles of Leather. Patented Oct. 15, 1846. Re-issued August 7, 1847. They declare that they do not now claim the manner of constructing this particular machine, but that the same has been described for the express purpose of showing to the workmen the practical mode of procedure in effecting such manufacture; but what they do claim and secure by letters patent, is the manner of making articles of leather, such as are designated; that is to say, the making them without seams or joinings, either by cement or otherwise; the leather of which they are made being split so as to leave solid edges as described. And this they claim irrespective of any particular machine or apparatus by which the splitting of the leather may be effected.

Insects are found in slate, and flies and ants in amber.





NEW YORK, OCTOBER 16, 1847.

**Geology System Makers.**

No science engages more attention at the present-day than Geology, and as it is an interesting study we presume that a brief sketch of many different opinions relative to the earth's history, will be both instructive and entertaining.

Kepler, the German Astronomer, believed the earth to be a great animal, and many other philosophers entertained as extravagant notions. Burnet, the author of the Sacred Theory, believed that the earth before the flood, was one beautiful plain without either mountains or seas, without any difference in seasons, "for its equator was in the plane of the ecliptic and turned directly opposite to the sun, enjoying a perpetual and luxuriant spring." He also believed that the earth was like a bomb shell, a round crust, enclosing an abyss of waters, which for the crimes of the antediluvians, God caused the shell to crack and fall in and the waters burst forth and engulfed the original inhabitants, with the exception of Noah and his family. Woodworth a better naturalist than Burnet, believed that the earth was composed of different layers like an onion, each layer occupying a place according to its specific gravity. Whiston again, believed that our earth was originally a comet, and that the creation of the earth as recorded in Scripture relates to the exact time when God placed it, as a planet, in our system.—He believed, that on the change of the motion of our comet-Earth its form was changed into regularity and beauty, by all the regular parts falling into their proper places, leaving the centre of the earth full of great heat which the comet received in its approach to the sun, and which he thought would continue 6000 years. He believed that the deluge was caused by the tail of a comet, and calculated with apparent certainty the exact day when this took place. Buffon believed that the planets, our earth among the number, were once parts of the sun, and were struck off by contact with a comet, like sparks from the red iron under the hands of the blacksmith. At first, he says, "our globe was a ball of liquid fire, but as it was driven from the sun it cooled and spun like a ball rolling on the ground and thus got that motion on its axis which flattened it at the poles and bulged it at the centre." Buffon also believed that all the shells found on the tops of the highest mountains and in the hardest rocks, were deposited by the sea at different periods of time, and such is now the common opinion; and Geology taking cognizance of these changes in Nature, accounts for the same by two causes, the *degrading* or wearing away cause, and the *elevating* cause. Cuvier reduced Geology to its present beautiful arrangement. He was undoubtedly the greatest naturalist since the days of Linnæus. Geology takes cognizance of the materials of the earth and of the order in which they are arranged and the causes which have effected that arrangement. There are two grand classes of strata; the non fossil and the fossil. The non-fossil Geologists say existed before any living thing and consequently no organic remains are found in them.—The science, by this arrangement can enable us to tell by what rocks are seen on the surface of the earth to judge of the strata underneath. Thus, when granite is found on the surface, no coal will be found underneath, as granite is a primary, coal a superficial strata. We are not able to discuss this subject at any length, but as the Association of American Geologists have just closed their annual meeting, we perceive that the huge round rocks called *boulders*, found throughout different parts of our continent, have engaged a large share of their discussions, in accounting for their origin, where they have come from and by what means. It appears that the theory

of their transportation is the age of Drifts.—That this continent was once the bed of the sea and that these boulders were brought from the North Pole by icebergs. This theory has a drift foundation, and we presume that we will be able to account for these boulders when we account for the original peopling of our continent. In alluding to any subject, we have always the object of practical benefit in view, and we are of opinion in reference to Geology and system makers, that considering the many syendid minds engaged in the pursuit of Geological knowledge, that too much time is vaguely wasted in the study of that which can do us no good—God alone can tell how the earth was created; but in regard to the different strata of the earth, and their order of arrangement, the science is beneficial and beautiful as a study to every man.

**New Enterprize.**

A project has recently been started for connecting New York with the interior by a ship canal. It is said that all New York will have to do to open a communication for ships of four thousand barrels freight from here to Chicago is to enlarge her lake canal from Troy to Lake Champlain and the Canadians will do the rest. With the ocean on one side and her Erie railroad and Erie canal on the other, and her northern ship canal giving her a ship communication with the Great Lakes, New York would enjoy a position for a mighty commerce such as no city ever enjoyed before

**Stone's Bed Sofa.**

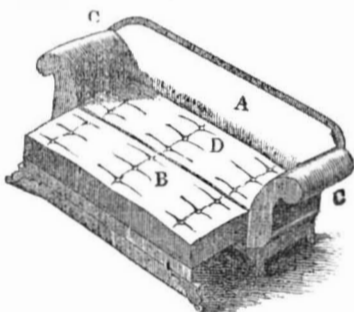

The above is an engraving of the beautiful Sofa Bedstead of Mr. Stone, of Charlestown, Mass., which we have noticed before in the Scientific American. A, is the scroll back of the sofa, and C C, the scroll sides. D, is the primary bed or seat, and B the moveable one, which is now represented as being open. B rests upon plane feet when spread out, and it can be easily lifted and set upon D, when B becomes a sofa seat, and then lift B, or rather slide it out to its place, as now seen by the above cut, and D B, is a double sofa bed. It is a very convenient and useful invention and practically operates well. It will be observed that there are two spring seats combined in this sofa. The inventor, we believe, wishes to dispose of his patent right.

**The Capstan Pump.**

While examining this pump at the Fair, a friend suggested to us the great superiority of Winder's pump, an engraving of which appeared in No 2 of the present volume of the Scientific American, over every other pump for nautical purposes. There would be no fear of lower valves getting out of order, as it has none, and, from any depth of hold, it could draw up the water from the ship's well as clean as a whistle.

**American Railroad Iron.**

The Philadelphia North American says that there will be sixty thousand tons of railroad iron manufactured in this country during the present year, which will be equal in quality to any imported iron. The value of this quantity, at present selling prices, will be upward of four millions of dollars. Pennsylvania, alone, furnishes one-half of the pig iron, and more than one-half of the railroad iron made in the United States.

**American Shipping.**

The intrinsic value of the shipping, (not including steamships, steamboats nor schooners) belonging to the United States, is put down at \$120,000,000 as a moderate estimate. The number of persons immediately interested, is stated, at a fair calculation, to be 1,175,000.

The highest peak of the Rocky Mountains is 12,500 feet, and James' peak is 12,000 feet.

**Electrotype and Electro Gilding.**

NO. II.

Copper can be deposited on moulds through the electric agency, as noticed in last number, by making these moulds of a negative character. The moulds are made as follows. It is well known that wax is a non-conductor, and would be well adapted for moulds but for its non-conducting properties. Mr. Murray and M. Jacobini, however, discovered that if wax was covered with blacklead it then became conductive, hence they made wax moulds and dusted the surface of them by a camel hair brush with the plumbago, breathing on the moulds to make the lead adhere. This mould or moulds (they do better when there is a number together,) is submitted to the action of what is called a constant battery, which will be better understood by the following cut.

FIG. 2.

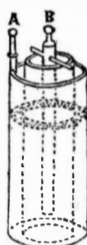

A, is an outside cylinder of copper, and B is a zinc rod coated with mercury, separated from the outside cylinder by an inside cylinder made of plaster of Paris or some porous substance of like nature. Into the outside cylinder is placed a solution of blue vitriol (sulphate of copper,) and into the inside cylinder a dilute solution of sulphuric acid. If a copper wire be then fixed into B by one end, and if on the other end there is a mould made of wax, as described, and that end be placed in the solution of sulphate of copper, the electricity from the zinc will in a short time separate the copper from the acid and deposit it on the mould as correctly as it by the hands of an engraver. A quantity of crystals of the sulphate of copper is placed generally on a small copper shelf near the top of the outer cell to feed the gradual deposit.

The wax for moulds is the same kind as used for candles, and it is to be melted for a mould and the medal, or article to be copied, must be made warm to prevent the sudden chill of the wax when poured on, and it must be surrounded with a ribbon of pasteboard. The surface of the medal should then be slightly covered with olive oil and the wax poured on. When it is allowed to cool gradually and when perfectly cool, the medal is to be slightly warmed with a candle to expand it, and then carefully removed from the wax. This mould then is to be treated with blacklead, as described, only on the face of it, and fixed to the end of a copper wire, by slightly heating the wire by a candle flame taking care to polish it well previously. To amalgamate the zinc rod of the battery, place some mercury in a saucer and pour on it some water and sulphuric acid and brush the liquid and mercury over the surface of the zinc rod till it is covered with a bright coat, when it is rendered fit for constant action.

**March of Locomotion.**

In a prospectus issued by the promoters of the Manchester and Liverpool Railway in the year 1839, it was stated, amongst the many advantages set forth, that the "average time of conveyance by water is 36 hours—by railway it will only be five or six hours." Since that time, what was by many deemed an impossibility, has really been brought to pass; and now the journey between the two places is performed in an hour. The distance between Manchester and London may now be traversed in the time in which it was computed would occupy a train in going to Liverpool; and yet we are assured, by practical and scientific men, that railway travelling is only in its infancy.

**Another Use for Ether.**

From a communication in the last number of the Boston Medical and Surgical Journal, it appears that a case of "delirium tremens" has been successfully treated by giving ether. The patient was an Irishman, named Perry, a man of sanguine temperament and of a strong and robust frame. He has been intemperate for many years.

**Electricity—Kite's Invention.**

There is a proposed plan in the British Builder, said to be invented by a Mr. Kite, for making the resistance of the atmosphere subservient to locomotion. The end in view is said to be attained by the guidance of the rush of air along a series of deflecting plates on the sides of the ash box which is divided into three longitudinal chambers, so that when the engine is in motion and exposed to the resistance or negative rush of the air, it impinges on these plates on its passage to the furnace and passing through the smoke pipe propels the engine with great force.

This project has been copied in some papers with the greatest gravity, as being a wonderful invention, and has been compared to the *compensating pendulum* and *harnessing* the opposing atmosphere.

In our opinion there is only one thing wanting to complete or make perfect the invention, and that is, some kind of buoy balloon, which can be attached to the locomotive, and lie in *statu quo* until there is danger of running off the track (which will be often enough if the impinging plates get out of line, or are heated more on one side than the other) when by a pneumatic pump the engineer can fill the balloon buoy with air and the train will be lifted over hollows and rivers without caring a straw for bridges or a fig for banks.

**Exceedingly Coppery.**

The editor of the Princeton Whig lets the public into a little knowledge of the Princeton Copper Mines. He has satisfied himself by personal observation that the "ore" of these mines can never be productive. He says that what the miners term copper and sulphuret of copper in these specimens, turns out to be on examination by scientific gentlemen, *sulphuret of iron*, an article of little value. There is copper, perhaps, in part of the specimens, but *not in that supposed to be the richest*.

**War Weapons.**

One thousand of Colt's Patent Revolving Rifles have been made at Hartford, for the use of the U. S. Mounted Rifle Regiment.—Each rifle is made to hold six charges, which can all be fired in as many seconds; and as they can be loaded very quickly, it is expected they will prove a terribly effective instrument of war. Gen. Taylor has approved them.

**A Ship Canal from Montreal to the Lakes.**

A plan is now in contemplation in Canada to connect Montreal with Lake Champlain, by a canal which, leaving the St Lawrence at Cannawaga, would lead through a level country over a distance of only 19 miles to St. Johns.—The present head of the steamboat navigation of Lake Champlain.

**Negro Suffrage.**

The people of Connecticut have defeated the proposed amendment to the Constitution, providing that colored men may vote, by a very large majority.

**Scientific American—Bound Volumes.**

The second volume of the Scientific American, bound in a superb manner, containing 416 pages choice reading matter, a list of all the patents granted at the United States Patent Office during the year, and illustrated with over 300 beautiful descriptive engravings of new and improved machines, for sale at this office—Price \$2,75. The volume may also be had in sheets, in suitable form for mailing—at \$2.

**THE SCIENTIFIC AMERICAN.**

Persons wishing to subscribe for this paper have only to enclose the amount in a letter directed (post paid) to

MUNN & COMPANY,

Publishers of the Scientific American, New York City

TERMS.—\$2 a year; ONE DOLLAR IN ADVANCE—the remainder in 6 months.

Postmasters are respectfully requested to receive subscriptions for this Paper, to whom a discount of 25 per cent will be allowed.

Any person sending us 4 subscribers for 6 months, shall receive a copy of the paper for the same length of time.]

**Useful Hints about Bed-rooms.**

Their small size and their lowness render them very insalubrious; and the case is rendered worse by close windows and thick curtains and hangings, with which the beds are often so carefully surrounded as to prevent the possibility of the air being renewed. The consequence is, that we are breathing vitiated air during the greater part of the night; that is, during more than a third part of our lives; and thus the period of repose, which is necessary for the renovation of our mental and bodily vigor, becomes a source of disease.—Sleep, under such circumstances, is very often disturbed, and always much less refreshing than when enjoyed in a well-ventilated apartment; it often happens, indeed, that such repose, instead of being followed by renovated strength and activity, is succeeded by a degree of heaviness and languor which is not overcome till the person has been some time in purer air. Nor is this the only evil arising from sleeping in ill-ventilated apartments. When it is known that the blood undergoes most important changes in its circulation throughout the lungs by means of the air which we breathe, and that these vital changes can only be effected by the respiration of pure air, it will be easily understood how the healthy functions of the lungs must be impeded by inhaling for many successive hours the vitiated air of our bed rooms, and how the health must be effectually destroyed by respiring impure air, as by living on unwholesome or nutritive food. In the case of children and young persons predisposed to consumption, it is of still more urgent consequence that they breathe pure air by night as well as by day, by securing a continuous renewal of the air in their bed rooms, nurseries, schools, &c. Let a mother, who has been made anxious by the sickly looks of her children, go from pure air into their bed room in the morning before a door or window has been opened, and remark the state of the atmosphere, the close, oppressive, and often fetid odour of the room, and she may cease to wonder at the pale, sickly aspect of her children. Let her pay a similar visit some time after means have been taken to secure a full supply and continued renewal of the air in the bed rooms during the night, and she will be able to account for the more healthy appearance of her children, which is sure to be the consequence of supplying them with pure air to breathe.

**The Rosse Telescope.**

The capacity of this instrument is wonderful. Such is its power that if a star of the first magnitude were removed to such a distance that its light would be three millions of years in reaching us, this telescope, would nevertheless, show it to the human eye. Is it to be wondered at, then, that with such an instrument grand discoveries should be made? It has been pointed to the heavens, and, although in the beginning only of its career, it has already accomplished many mighty things. There are nebulous spots in the heavens which have baffled all the instruments hitherto constructed, but this telescope resolves their true character completely. Among the wonderful objects which have been subject to its scrutiny is the nebula in the constellation Orion. I have had an opportunity to examine it. It is one of the most curious objects in the whole heavens. It is not round, and it throws off various lights. From the time of Herschell it has been subjected to the examination of the most curious instruments, but it grew more and more mysterious and diverse in its character. When Lord Rosse's great telescope was directed to its examination, it for a long time resisted its power. He found it required patient examination—night after night, and month after month. At length a pure atmosphere gave him the resolution of its constitution; and the stars of which it is composed burst upon the sight of man for the first time.—*Mechanics Magazine.*

In Leverett, Mass a child of Peter Hobart Jr., of Boston cut the arteries of his arm with a scythe, but was prevented from bleeding to death, by the presence of mind of his mother, in pressing the flesh above the wound, until the doctor arrived two hours after, and took up the arteries.

**A Singular Iron Man Petrification.**

The Cincinnati Chronicle says that a gentleman brought into Portsmouth, from the Bloom Furnace, Scioto, county, a part of an iron man, found in the *ore bed!* The part we saw was the foot and a part of the leg. Having been converted into iron by a gradual process, the minutest divisions, as between the toes, &c., were not visible; but the general outline of the foot and ankle were palpable. The spreading across the toes—the general outlines of the toes—the heel—ankle, &c. were perfectly plain. We were told that the head and arms are still more perfect! There cannot be the least doubt of its having been a man. Nor is there much doubt of the manner in which it came in this condition. The body must originally have been petrified in lime; but of this there remains now only the outside incrustation, which will crumble off. What was the man, is now iron. By some natural process the iron must have grown out of the lime, and here is a theme for Geologists! How did this change take place? If we are right, and the facts seem to leave no room for doubt, this Iron Man would afford one of the most beautiful subjects for a Geological lecture. The Iron Ore, in which it was found is called the Calcareous Formation. The process of its formation, would be an instructive study.

**Small Potatoes.**

This term is so generally reproachful that the person or thing to which it is applied are placed in the lowest attitude. But even small potatoes should not be despised, as the following facts, which were related to us (says the Portsmouth Journal) by one of our townsmen who derived most profit from the proceeding fully illustrates:

Some years ago a gentleman visiting a farmer in Tolland, Connecticut, took from his pocket a small intruder which somehow got in there at home. It was thrown out with a smile, and the farmer taking it in his hand to look at it, a curious little boy of twelve at his elbow asked what it was. "Oh, nothing but a potato my boy—take and plant it, and you shall have all you can raise from it till you are free." The lad took it, and the farmer thought no more about it at that time. The boy, however, not despising small potatoes, carefully divided it into as many pieces as he could find eyes, and put them in the ground; the product was carefully put aside in the fall, and seed for several hills was obtained for the next spring. The product was all kept for seed until, in the fourth year, the yield being good, the actual product was four hundred bushels! The farmer, seeing the prospect that the potato field would by another year cover his whole farm, asked to be released from his promise,

With the same calculation, prudence, and industry, how many who are disposed to regard the trifling things on which fortunes are built as too *small potatoes* to receive their attention would have been in independent circumstances if they had husbanded their small advantages! *Small potatoes* should not be despised, even though there be at first but a few in a hill.

**A Hungry Printer.**

One of our western exchanges concludes a pathetic appeal to his subscribers, by enumerating what a printer wants. He asks for forty or fifty bushels of potatoes, one hundred do of corn, fifty heads of cabbage, some linen to make up shirts and chemisettes for himself and better half, half a dozen pigs, cotton flannel for under clothes, children's nightcaps, and all the cash they can spare. He says without the latter indispensable article, he cannot keep the wheels in motion.

What an unconscionably avaricious fellow.—How dare a printer aspire to potatoes, or think of wearing a shirt!

**A Chance for Emigrants.**

The State of Arkansas invites emigrants to come and take lands which have been forfeited for taxes, and no payment will be required of them. The auditor upon proof of settlements will make a deed, which the supreme court has decided will be valid. The forfeited tracts comprise some of the finest lands in the State.

**Female Professorships.**

A leading French paper has a series of able essays entitled "*Du Professorat des Femmes*," showing the impropriety of employing at all in the education of girls, and the sufficiency and superiority of female professors for those branches of instruction which are usually supposed to require male tuition. We translate a passage or two, which will show the drift of the articles we speak of: "The least reflection will be sufficient to show that the male professor, in a female seminary, if he is young, must at least take off attention from study, if he excites no other interest. If he is old and of very grave character, he inspires a sentiment of dread and repulsion which depresses emulation and chills the desire to please by proficiency. If he is debonaire in his manners, his pupils ridicule him, and are more amused with the man, than improved by his lessons. The abuse which instructors have made of their access to the minds and intimacy of young girls who are secluded from all other male society, will recur in their varied instances to the memory of the reader, and the conclusion to be drawn from this is obvious. The objections to a substitution of female teachers are, it seems to us trivial and unfounded. It is said that women have not force of character enough to inspire the necessary respect and control: that they lack firmness and consistency in their requisitions; that masculine superiority and dignity are necessary properly to restrain and intimidate, and that female teachers are rarely finished enough in their own education." With this glimpse at the material of the argument the readers of this Journal will be enabled to discuss it for themselves and we leave it, merely suggesting that the question touches also upon another interest quite as important: the increase of vocations for the exercise of female industry.

**The Favorite Mexican Stimulant.**

Every nation loves to intoxicate itself, and the Mexican boasts of the most nauseous invention for the purpose among the discoveries of man. Pulque, the national beverage is the juice of the *Agave Americanus*, fermented. The original process by which fermentation is produced is one which we shall not venture to detail; but the liquor obtained from the section of the plant is drawn up by the rude syphon, and poured into dressed ox-hides. The taste is mawkish, and the smell is noisome. Yet, to the Mexican, it is nectar and ambrosia together. Pulque is to him meat, drink, and clothing, for without it the world has no pleasures. The most remarkable circumstance is that it is without strength. Thus it wants the charm of brandy, which may madden, but which at least warms; or aquafortis, which the Pole and the Russian are said to drink as a qualifier of their indulgence in train oil; but the Mexican, would rather die, or even fight, than dispense with his pulque, and if Santa Anna had but put his warriors on short allowance of the national liquor before his last battle, and promised them double allowance after it, he would probably have been, at this moment, on the Mexican throne.

**War on the Cotton Worm.**

The Woodville, Miss., Republican records a very interesting circumstance in what follows. After saying "we hear little or no complaint of the worm at present," that paper of the 18th adds.—"A little fly, called by some the 'ichneumon,' in consequence of similarity between its habits and those of the Egyptian animal, seems to have taken the worm and cryalis in hand, and devoured nearly all of them. This they do, we are told, by boring into the shell or cryalis and eating its contents. Myraids of the cryalis may be found in the cotton fields thus conditioned, and had it not been for this fact our fields would doubtless have been destroyed before now. What a wise order of Providence, and what an impressive example of a trust in his dispensations."

**Old Boots and Shoes.**

Prussian blue is now manufactured extensively in Philadelphia by the burning old boots and shoes.

Otto of roses is the oil which swims on top in the distillation of rose water.

**The Palmyra Tree.**

The Palmyra grows 100 feet high, with a stem perfectly straight. The wood though fibrous like the cocoanut tree, is more compact and will take a fine polish. Inside pithy. It is used for building, but not furniture, as it cannot be sawed into planks. The leaves look like fans spread out. The fruit grows in clusters at the top, among the leaves, nearly round, and covered with a thin purple membrane. When the fruit is first found, the seed-shell is filled with a transparent substance which is viscous and elastic, like jelly, cool and agreeable to the taste. The fruit, on being pressed yields a thick juice of a reddish yellow, and of a strong flavor, looking like boiled and strained pumpkin. This is spread, half an inch thick, on mats and dried a few days in the sun, and stored for wood. It keeps some months in this state, and is very nutritious, though to foreigners unpalatable. The seeds are buried in heaps in the earth, and after a few weeks, are found to have shot out an esculent root, of the spindle class, of the size of a small parsnip, which also furnishes much nutriment, is dried, pulverized and made into cakes, soup &c.

The sap of the tree is treated like that of the coccanut. These two trees are put to a great variety of uses. The wood of the Palmyra furnishes staves and rafters for the houses, the leaves are used for thatch, fence, books, mats, baskets, &c. Ropes as well as baskets and mats are also made from the strong rind of the Palmyra leaf, and the blossom and fruit supply the people with a large part of their food.—It is supposed that the Palmyra furnishes means of subsistence to a fourth of the population.

**Quantity of Breath in Man and Woman.**

The French are a most experimenting race, and their discoveries in arts and sciences, proverbially in advance of other nations. By experiments made at the Academy of Sciences, and arrived at by an ingenious species of mask being placed over the face of the person whose breath was to be examined, it was ascertained that man gives out much larger quantity than woman and this difference is most striking between the ages of 16 and 40 at which latter period the quantity of carbonic acid given out by the male is double that of the female. In the male the quantity goes on increasing from the age of 8 years to 30, after which it begins to diminish; and, as a man becomes older and older, the diminution goes on in an increased degree. In old age the quantity is not greater than at the age of ten.

**The Rocks of Calvary.**

In Fleming's Christology, it is stated that an unbeliever visiting the sacred places of Palestine, was shown the cliffs of Mount Calvary. Examining them narrowly and critically he turned in amazement to his fellow travellers and said, "I have long been a student of nature, and I am sure the clefts and rents in this rock were never done by nature, or an ordinary earthquake; for, by such a concussion, the rock must have split according to the veins, and where it was weakest in the adhesion of parts; for this" said he, "I have observed to have been done in other rocks when separated or broken after an earthquake; and reason tells me it must always be so. But it is quite otherwise here; for the rock is split athwart and across the veins, in a most strange and preternatural manner; and therefore," said he "I thank God that I came hither to see the standing monument of a miraculous power by which God gives evidence to this day of the Divinity of Christ."

**Hard of Hearing.**

An old trick says an Albany paper, was played on the Sheriff at the present term of the court. He was short for jurors, and made a descent in the street. He accosted a gentleman well known in town, with, "I want you in court for a juror." "Ha," replied the man, "speak a little louder." The Sheriff pitched his voice to a high key, "I want you for a juror." "Yes, yes," nodding his head very significantly, "it is a very fine day." The Sheriff taking him for a deaf man bolted. The wag placed his thumb to his nose, and went through the motions.



**TO CORRESPONDENTS.**

"J. P. J. of Ct."—We are obliged to you for your information on tinning, and shall endeavor to make the best use of it.

"M. H. of Watertown, N. Y."—We cannot give you the least clue to those you are in quest of, nor the process of their invention.

"K. V. of New York."—You are not afraid to open an extensive field of enquiry. We do not feel ourselves at liberty to answer your question. Prudence should have dictated to you different interrogatories.

"K. of Maine."—We have no doubt but your article is a good one, but certainly it is very difficult to read it. Yet we shall try, as it is not a common one. It would be of no apparent avail to build another stationary box to the common pump.

"J. S. of N. Y."—There is a planet called Vulcan, lately discovered, and more will yet be found between us and the sun, as we stand upon a solar system shaped like a convex shield and astronomers have not always looked towards its edge or its centre. An answer to all your interrogatories would take up too much space in our columns, and there is one we cannot answer. We have something in view, however, when we get time to insert it, after a careful study in the meantime. Professor Nicholson's late work will give you all the information you want up to the time of its publication last year. We suppose you may find it at Appleton's.

"W. T. of Highland, Ohio."—You will find all the information you enquire for in Vol. 2 Scientific American.

"H. S. B. of N. Y."—We should not think it any object to comply with your request.

"R. D. W. of Middletown, Pa."—We procured your platina wire and sent it about ten days ago.

"Br. S. of Waterloo."—We are happy to hear from an old friend.

"W. K. of Allegheny, Pa."—The ten dollar note was duly received last Tuesday.

**Patent Agency.**

Applications for Patents made at this office, on the most reasonable terms. Neat drawings, specifications, and engravings of the first character, and cheaper than anywhere else. Notices of new inventions, Agency for the sale of Patent Rights, and all business of that nature, promptly attended to. Those who have patent rights to dispose of will find a good opportunity and field for their sale—such as Horse Power Machines and Waterwheels of every description. The largest circulation in the world for advertisements of inventions, &c.

**Turning Lathes.**

Those who wish for the best Turning or Screw Cutting Lathe in use, are invited to notice the advertisement of G. B. Hartson, in another column. One of the machines may be seen in operation at the Fair.

As soon as the fact of the Robbery of \$1000 from Adams and Co's Express came to the knowledge of these gentlemen, they sent a check to the owner of the lost money for the amount, thus taking the loss upon themselves.

In Nauvoo, Mr. Hatch, a revolutionary pensioner 90 years old, and Mr. Telley another Mormon, shot their wives dead in the night by mistake, supposing them to be anti-Mormons from whom they expected an attack.

The City of Boston proper originally contained but 600 acres of land; and now it embraces 1300, so that 700 acres have been added to it artificially by the spade.

A specimen of cotton, grown in Australia, has been submitted to Messrs. James and John Wright, of Glasgow, who consider it a very useful and valuable description.

The New York, Albany and Buffalo Telegraph Company have declared a dividend of four per cent. A dividend of three per cent was paid in February, making seven per cent the first year of operation.

The mountains of Seger, in Arabia produce frankincense; and those of Safra, the balm of Mecca, from the amyris opobalsamum, which in the early ages sold for its weight in gold.

**Island City.**

Persons wishing to subscribe for an excellent literary paper, are invited to notice the advertisement of the Island City in the advertising columns.

**Advertisements.**

This paper circulates in every State in the Union, and is seen principally by mechanics and manufacturers. Hence it may be considered the best medium of advertising, for those who import or manufacture machinery, mechanics tools, or such wares and materials as are generally used by those classes. The few advertisements in this paper are regarded with much more attention than those in closely printed dailies.

Advertisements are inserted in this paper at the following rates:

One square, of eight lines one insertion,	\$ 0 50
" " " " two do.,	75
" " " " three do.,	1 00
" " " " one month,	1 25
" " " " three do.,	3 75
" " " " six do.,	7 50
" " " " twelve do.,	15 00

TERMS:—CASH IN ADVANCE.

**GENERAL AGENTS**

FOR THE SCIENTIFIC AMERICAN.

New York City, - - - - - GEO. DEXTER.  
Boston, - - - - - MESSRS. HOTCHKISS & CO.  
Philadelphia, - - - - - STOKES & BROTHER.

**LOCAL AGENTS.**

Albany, - - - - - PETER COOK.  
Baltimore, Md., - - - - - S. SANDS.  
Cabotville, Mass., - - - - - E. F. BROWN.  
Concord, N. H., - - - - - RUFUS MERRELL.  
Fall River, Mass., - - - - - POPE & CHACE.  
Hartford, Ct., - - - - - E. H. BOWERS.  
Jamestown, N. Y., - - - - - E. BISHOP.  
Lynn, Mass., - - - - - J. E. F. MARSH.  
Middletown, Ct., - - - - - W. M. WOODWARD.  
Norwich, Ct., - - - - - SAFFORD & PARKS.  
New Haven, Ct., - - - - - E. DOWNES.  
New Bedford, Mass., - - - - - ROBINSON, PARSONS & CO.  
Newark, N. J., - - - - - J. L. AGENS.  
Newark, N. J., - - - - - Robert Kashaw.  
Providence, R. I., - - - - - H. & J. S. ROWE.  
Rochester, N. Y., - - - - - D. M. DEWEY.  
Springfield, Mass., - - - - - W. M. B. BROCKETT.  
Salem, Mass., - - - - - L. CHANDLER.  
Saco, Me., - - - - - ISAAC CROOKER.  
Savannah, Geo., - - - - - JOHN CARUTHERS.  
Troy, N. Y., - - - - - A. SMITH.  
Taunton, Mass., - - - - - W. P. SEEVER.  
Williamsburgh, - - - - - J. C. GANDER.  
Dover, N. H., - - - - - D. L. NORRIS.

**CITY CARRIERS.**

CLARK SELLECK, SQUIRE SELLECK.

Persons residing in the city or Brooklyn, can have the paper left at their residences regularly, by sending their address to the office, 128 Fulton st., 2d floor.

**Ballard's Improved Jack Screw.**

THE advantages of this Screw for Stone Quarries, Railroads, Steam-boiler Builders, and for other purposes, are superior to any other similar machine. The improvement consists in being able to use either end of the screw, as occasion requires. It is capable of raising the heaviest Locomotive with ease, being portable, strong and powerful, and not likely to get out of order. Many Railroad Companies and Boiler makers have them in use, by whom they are highly recommended.

**JACK SCREWS,**

Of various sizes, power and price, constantly on hand at the manufactory,  
No. 7 Eldridge street, near Division.  
o16

**To Machinists, Carpenters and others.**

MR. WM. A. ASHE, Professor of Mechanical and Architectural Drawing intends opening Evening Classes for the purpose of giving instructions in Architectural and Mechanical Drawings, in all their branches, from the first use of the instruments to the highly finished and beautifully shaded drawing, suitable for framing or the Patent Office. W. A. ASHE'S Drawings have gained him many prizes in several Mechanics' Institutions in Europe, and great reputation in the Patent Office, Washington, and the Mechanics' Institute, Brooklyn, (where he was a teacher for two years), and among the various Patent Agents of this city. As the classes will be limited, an early application will be necessary to insure admittance. For terms and particulars, apply to W. A. ASHE, at his establishment, 133 Fulton street, opposite the Sun Buildings. o9

**Johnson's Improved Shingle Machine.**

THE Subscriber having received Letters Patent for an improvement in the Shingle Machine, is now ready to furnish them at short notice, and he would request all those who want a good machine for sawing shingles, to call on him and examine the improvements he has made, as one eighth more shingles can be sawed in the same given time than by any other machine now in use. Augusta, Maine, Oct. 1, 1847. J. G. JOHNSON.

**Machinists Tools.**

THE Subscriber is now manufacturing a superior article of Large Turning and Screw Cutting Lathes, Drilling Machines, &c. to which he would respectfully call the attention of Machinists and others requiring the above articles. Also, Machinery of every description, manufactured to order, at 42 Gold street, New York. G. B. HARTSON. o3 1m\*

**Veni! Vidi! Emi!**

THIS IS THE MOTTO OF ALL THOSE THAT HAVE EXAMINED KNEX'S NEW FALL STYLE OF HATS, with a view to buying—  
**I CAME! I SAW! I BOUGHT!**  
His BON TON Establishment (as all know) is at 123 Fulton street. s18 3m

**MAGNIFICENT PORTRAIT OF MAJ. GEN. ZACH. TAYLOR.**

The undersigned have just issued a magnificent likeness of GENERAL TAYLOR, DRAWN FROM LIFE and engraved in the most COSTLY MANNER, which is now for sale at the extremely low price of

**Six cents per copy.**

A LIBERAL DISCOUNT TO THE TRADE.

This likeness is warranted to be the most perfect of any which has yet been published, and the only reason for offering it at so low a price is to insure the sale of an immense quantity.

The Portrait is encircled by a beautiful wreath, adorned and surrounded with appropriate designs.

Any person enclosing QUARTER OF A DOLLAR in a letter, shall receive FOUR COPIES by mail. Ten copies for fifty cents; Twenty-five copies for one dollar. Letters must be directed (post paid) to

MUNN & CO.

Publishers of the Scientific American, New York City.

OBSERVE—As this is the only true likeness issued, it may be known from all others by having the words "PUBLISHED BY MUNN & CO. AT THE OFFICE OF THE SCIENTIFIC AMERICAN, NEW YORK," printed on the lower part. s4

**A VALUABLE FAMILY NEWSPAPER.**

Agreeable to the announcement of the Publishers,

**THE ISLAND CITY**

Of the second of October was ENLARGED, so as to contain nearly double its original quantity of reading matter; making it the largest Saturday paper published in the Union! Its price will remain the same, viz. (to mail subscribers) only

**\$1 per annum, or 25 cents for 3 months.**

By this new arrangement they secure to the columns of the Island City a greater variety of reading matter, and in addition to their regular series Original Novels and Romances, they will introduce several new features, among which will be found:—  
*Town Topics, Local Sketches, Police News, Items, the Table D'Hote, the Drama.*

**PREMIUMS.**

All new subscribers will be entitled either to the powerfully written Sea Novel, called the Meteor, or Cutter of the Ocean; or to the domestic novel of Walter Wolfe, or the doom of the Drinker.

In every city, town or village a club can readily be formed by any person who will give a few hours attention to such object. To all such who will remit us FIVE DOLLARS we will furnish SIX COPIES of the paper; including in every case the above premium. Address W. B. SMITH & CO., Publishers of the Island City, 75 Chatham st. New York. o16

**REMARKABLE CASE OF FITS CURED.**

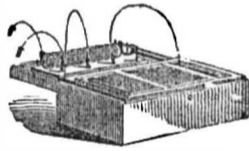

**Dr. Smith's Torpedo Magnetic Machine.**

The following is an extract of a letter from Dr. William Miller, No. 317 Broome st., New York.

Dr. S. B. SMITH—Sir: To show the superior efficacy of Electro-Magnetic treatment over every other, I will give you a case of Fits that I completely cured in two operations by the above process:—  
A Mrs. Abrahams near Nyack, in Rockland Co., N. Y., came to me on the morning of March 13, 1846, with a child about 4 years old, who had for many months had fits regularly every day at 2 o'clock and 6 o'clock, P. M. The intellect of the child showed symptoms of decay from their frequency and severity. After the first operation the lady left for her boarding place, in full confidence that a cure was already effected, although I assured her it was not possible that one application could suffice. The next morning I found her waiting upon my office steps eager to inform me that both two and six o'clock of the afternoon passed without a return of the fits, and that she felt confident the child was cured. I bade her bring the child in and submit it another operation. She did so, and to this date the child has remained well. The cure was effected solely by the Electro Magnetic treatment, no other medicine whatever being given. I might give you many other cases where the cure has been perfect by a more lengthy treatment. W. M. MILLER, August 19, 1847. 317 Broome st., N. Y.

A manual with full directions, accompanies each machine, which is warranted for 20 years, put up in elegant rosewood and zebra wood cases, 9 inches long, 5 1-2 inches wide and 5 high—Price \$12. Orders from any part of the United States promptly attended to. Address MUNN & CO. (post paid) New York. o2 tf

**WOOD CUTS.**

We would inform Newspaper and Periodical publishers that we have on hand a large lot of Wood Engravings, which have been used in the Scientific American during the past year, which we are desirous of disposing of CHEAP. They are in fine order and may be had at one fourth of their original cost. Publishers of country papers would find it to their interest to avail themselves of this chance to illustrate their publications at a cheap rate. Address at this Office. s18 tf

**Lap-welded Wrought Iron Tubes FOR TUBULAR BOILERS,**

From 1 1-4 to 6 inches diameter, and any length, not exceeding 17 feet.

THESE Tubes are of the same quality and manufacture as those extensively used in England, Scotland, France and Germany, for Locomotive, Marine and other Steam Engine boilers. THOMAS PROSSER, Patentee, 28 Platt street, New York. d26

**THE NEW YORK WEEKLY SUN.**

A large and handsome newspaper, containing THIRTY-TWO COLUMNS of interesting reading matter, printed in clear type on fine paper, is published every week at the low price of

**ONE DOLLAR A YEAR.**

SINGLE COPIES THREE CENTS EACH.

Each number generally contains an engraving on some interesting subject—two or three interesting tales or sketches, each complete—several pieces of beautiful poetry—miscellaneous articles on various subjects—hints on domestic economy—agriculture—inventions—recipes—wit—humorous anecdotes—editorials, selected from the Daily Sun—news of the week—list of deaths and marriages—markets, foreign and domestic—arrivals and clearances—vessels or foreign ports—prices current—a complete bank note list—list of passengers arrived and departed.

The Weekly Sun was established TEN YEARS AGO, since which time it has rapidly increased, until it has attained its present large circulation, and is now perhaps the best medium for country advertising which can be found. Advertisements inserted at a low rate.

Subscription ONE DOLLAR A YEAR, sent by mail to any part of the United States and the Canadas, by steamers and packets, to all parts of England, Scotland, Wales, Ireland, France, Germany, Spain, the West Indies and South America. Published at the office of the New York Sun, south-west corner of Fulton and Nassau streets. Letters from the country should be addressed, post paid, to

M. Y. BEACH & SONS, Sun Office, New York.

**BOOKS! BOOKS!!**

We would inform those who are desirous of procuring the New Series of valuable and interesting publications now issuing by Messrs. Fowlers & Wells, that we have made arrangements with them whereby we can furnish their works at Publishers' prices.

JUST ISSUED.

Matrimony—Hints on selection of companions - Price 25 cents  
Fascination, or the Philosophy of Charming 40 cents  
Woman—her education and influence - 40 cents  
Chemistry—its various new and novel applications - 20 cents  
Lectures on the Philosophy of Mesmerism 25 cents  
Phrenological Almanac, per dozen, 50 cents.  
The above works may all be sent by mail. Address, post paid,

MUNN & CO., Publishers, Fulton street, N. Y. j17

**PATENT AGENCY AT WASHINGTON. ZENAS C. ROBBINS,**

Mechanical Engineer and Agent for procuring Patents.

WILL prepare the necessary Drawings and Papers for applicants for Patents, and transact all other business in the line of his profession at the Patent Office. He can be consulted on all questions relating to the Patent Laws and decisions in the United States or Europe. Persons at a distance desirous of having examinations made at the Patent Office, prior to making application for a patent, may forward (post paid, enclosing a fee of five dollars) a clear statement of their case, when immediate attention will be given to it, and all the information that can be obtained by a visit of the applicant in person, promptly communicated. All letters on business must be post paid, and contain a suitable fee, where a written opinion is required.

Office on F street opposite Patent Office. He has the honor of referring, by permission, to Hon. Edmund Burke, Com. of Patents; Hon. H. L. Ellsworth, late do; H. Knowles, Machinist, Patent Office; Judge Cranch, Washington, D. C.; Hon. R. Choate, Mass., U. S. Senate; Hon. W. Allen, Ohio, do; Hon. J. B. Bowlin, M. C. Missouri; Hon. Willis Hall, New York; Hon. Robert Smith, M. C. Illinois; Hon. S. Breese, U. S. Senate; Hon. J. H. Relfe, M. C. Missouri; Capt. H. M. Shreve, Missouri. j23

**GENERAL PATENT AGENCY. REMOVED.**

THE SUBSCRIBER has removed his Patent Agency from 12 Platt to 189 Water street. The object of this Agency is to enable Inventors to realize something for their inventions, either by the sale of Patent Goods or Patent Rights. Charges moderate, and no charge will be made until the inventor realizes something from his invention. Letters Patent will be secured upon moderate terms. Applications can be made to the undersigned, personally or by letter post paid. s3 3m\* SAMUEL C. HILLS, Patent Agent.

**DAUGERRIAN GALLERY. GURNEY'S**

PREMIUM DAUGERRIAN GALLERY. No. 189 Broadway, N. Y. Pictures taken at this establishment warranted to give satisfaction. j24

**AGRICULTURAL TOOLS.**

INVENTORS and Makers of superior Agricultural Implements are notified that the subscriber will sell such articles on commission, and make prompt returns. s3 3m\* SAMUEL C. HILLS, 189 Water st.

**AMERICAN HARDWARE.**

THE SUBSCRIBER having been engaged in selling American Hardware on commission for 7 years, solicits assignments from manufacturers, and will refer to those who have employed him the above number of years. SAMUEL C. HILLS, m3 3m\* 189 Water st.

**Engraving on Wood**

NEATLY AND PROMPTLY EXECUTED AT THE OFFICE OF THE SCIENTIFIC AMERICAN, 123 Fulton st., three doors from the Sun Office. Designs DRAWINGS of all kinds for PATENTS, &c., also made as above, at very low charges.



### The Motive Power of Coal and Zinc.

At the present moment, electro-magnetism as a moving power, is engaging great attention and study; wonders are expected from its application to this purpose. According to the sanguine expectations of many persons, it will shortly be employed to put into motion every kind of machinery, and among other things it will be applied to impel the carriages of railroads, and this at so small a cost, that expense will no longer be matter of consideration.

With a simple flame of spirits of wine, under a proper vessel containing boiling water, a small carriage of 200 or 300 pounds weight can be put in motion, or a weight of 80 or 100 pounds may be raised to a height of 20 feet. The same effects may be produced by dissolving zinc in dilute sulphuric acid in a certain apparatus. This is certainly an astonishing and highly interesting discovery; but the question to be determined is, which of the two processes is the least expensive?

In order to answer this question, and to judge correctly of the hopes entertained from this discovery, let us notice what chemists denominate "equivalents." These are certain unalterable ratios of effects which are proportionate to each other, and may therefore be expressed in numbers. Thus, if we require 8 pounds of oxygen to produce a certain effect, and we wish to employ chlorine for the same effect, we must employ neither more nor less than  $35\frac{1}{2}$  pounds weight. In the same manner, 6 pounds weight of coal are equivalent to 32 pounds weight of zinc. The numbers representing chemical equivalents express very general ratios of effects, comprehending for all bodies all the actions they are capable of producing.

If zinc be combined in a certain manner with another metal, and submitted to the action of dilute sulphuric acid, it is dissolved in the form of an oxide; it is in fact burned at the expense of the oxygen contained in the fluid. A consequence of this action is the production of an electric current, which, if conducted through a wire, renders it magnetic. In thus effecting the solution of a pound weight, for example, of zinc, we obtain a definite amount of force, adequate to raise a given weight one inch, and to keep it suspended; and the amount of weight it will be capable of suspending will be the greater the more rapidly the zinc is dissolved.

By alternately interrupting and renewing the contact of the zinc; and, setting aside the name given to the force in this case, we know that it can be produced in another manner. If we burn the zinc under the boiler of a steam engine, consequently in the oxygen of the air, instead of the galvanic pile, we should produce steam, and by it a certain amount of force. If we should assume, that the quantity of force is unequal in these cases—that, for instance, we had obtained double or triple the amount in the galvanic pile, or that in this mode of generating force less loss is sustained—we must still recollect the equivalents of zinc and coal, and make these elements of our calculation. According to experiments made 6 pounds weight of zinc, in combining with oxygen, develop no more heat than 1 pound of coal; consequently, under equal conditions, we can produce six times the amount of force with a pound of coal as with a pound of zinc. It is therefore obvious that it would be more advantageous to employ coal instead of zinc, even if the latter produced four times as much force in a galvanic pile, as an equal weight of coal by its combustion under a boiler. Indeed it is highly probable, that if we burn under the boiler of a steam engine the quantity of coal required for smelting the zinc from its ores, we shall produce far more force than the whole of the zinc so obtained could originate in any form of apparatus whatever.

### Water as Fuel.

This seemingly strange idea originated in an occasional remark of Sir Humphrey Davy, that, on the problematic exhaustion of coal, men will have recourse to the hydrogen of water, as a means of obtaining light and calefaction. As the gas used for lighting consists of hydrogen and a little carbon, it is only the latter which would have to be added, after the water had been decomposed into its elementary parts. M. Jobard, of Brussels, was the first who extracted from water a gas, of twice as great an illuminating power as that obtained from coal. This gentleman produces hydrogen gas by the decomposition of vapour passing through vertical retorts filled with coke, being in a state of white heat. And at the moment of the light being thus formed, it is mixed with a little carbonic acid gas, obtained by the distillation of oil, tar or naphtha, or other coarse substance, hitherto useless in gas manufactory. He says that at the expense of one pennyworth of oil a light may be obtained during twenty hours, equalling that of ten tallow candles. Even conceding that M. Jobard's discovery has not quite attained the object of using water for light, fuel, &c., still it has done something towards it. Professor Faraday says that the elements of a single molecule of water, contains 800,000 charges of an electric battery consisting of eight troughs of two inches in height and six inches in circumference. At the amount of these slumbering forces the human mind is startled; because, if we should ever be able to elicit and make them available, the power of the mightiest steam engines would dwindle to nothing, and thus ends would be attained by the means of things seemingly trifling and worthless, which cannot now be accomplished by any sacrifice of expense.

### Hydrogen and Oxygen Gas.

If two parts of common air and one part of hydrogen be mixed in a strong vial capable of holding four ounces of water, it will inflame on presenting a candle to it, with a loud report. The result is water.

Take two parts of granulated zinc and one part of phosphorus and put them into a vial with half an ounce of water and a quarter of an ounce of sulphuric acid; in a short time phosphuretted hydrogen gas will be produced and beautiful blue jets of flame will be seen to dart from the bottom of the liquid while its surface will be covered with a very luminous smoke.

### To obtain Heights which cannot be measured.

Take any two rods of unequal length, place the short rod at any convenient distance from the building, and the long rod at such a distance from it, that looking over the short rod to the top of the building, the top of the long rod shall cut that sight. Then say, as the distance between the rods is to the height of the long rod over the short one, so is the distance of the long rod from the building to the height of the building, to which result add the short rod, and you have the height of the building.

### MECHANICAL MOVEMENTS.

#### Amand's Escapement.

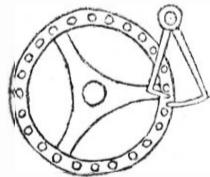

Tooth and pinion work have long since been used to regulate motion and in the application of machinery no department of mechanism has been brought to such a state of perfection as the art of watch and clock making, especially chronometers. The perfection to which chronometers are now brought as guides to navigators on the pathless ocean, ought to be a special subject of gratitude to all men, as with the great commerce of the world at the present day, in comparison with any age of the past, by this little, but beautiful instrument, the dangers of navigation are much lessened from what they were before the chronometers became a substitute for the deadlog reckoning. Watches and time keepers, however, were not brought to their present state of perfection in a single day. The process of

improvement has been going on for centuries. The above cut is a representative of Amand's dead beat escapement, the principle of which we explained in a former article. He was famous as a watch maker in France, and instead of the ratchet wheel and clutches, he used, as will be perceived, the pinion and pallets on the balance, which vibrating on a small centre to the right in the cut, allowed one pin of the wheel to escape at each vibration of the pendulum.

#### Pneumatic Engine.

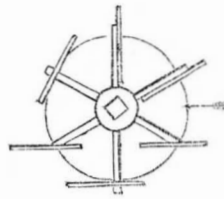

There have been various forms of the wind mill, some made with latteen and others with canvass sails, and among some variations, the machine represented in the above engraving has been used, but has not been considered so good or valuable as the common wind mill. It will be observed that the sails swing upon variable axles or shafts so that supposing the wind to be in the direction of the arrow, the sails have been contrived to present the edge on returning towards the wind and thus to produce circular motion and drive the main shaft.

#### Soap.

As soap is at present every where used for washing, the question arises what substitutes were employed before it was invented. Those with which I am acquainted I shall mention and endeavour to illustrate. They are still used though not in general; and they are all of a soapy nature, or at least have the same effects as soap, so that we may say that the ancients used soap without knowing it. Our soap is produced by a mixture of lixivious salts and tallow, by which means the latter becomes soluble in water. The greater part of the dirt on our linen and clothes consist of oily perspirations or grease, or dust which that grease attracts, and which either cannot be washed out, or but very imperfectly, by water alone. But if warm water, to which lixivious salts have in any manner been added, be taken, and if dirty cloth be rubbed in it, the greasy dirt unites with the salts, becomes saponaceous, and is so far soluble in water that it may be washed out. There are also natural juices which are of a soapy nature in the state in which we find them, and which can be employed in the stead of artificial soap. Of this kind is the gall of many animals and the sap of many plants. The former being less strong in its effects, on account of its slimy nature, is used at present particular for colored stuffs, the dye of which is apt to fade.—*Beckmann's History of Inventions.*

To throw some practical light upon Mr. Beckmann (whose work, old as it is, should not be despised but which would have been far more valuable had its modern publishers added the progress of inventions) we would advise those who have fine muslins of chaste and elegant colors, to boil some bran in rain water and use the pure liquor cold for washing. Nothing can be so simply done, and nothing can equal it for ease upon the colors and for cleaning the cloth.

#### Peat Composition.

The French have lately made a discovery well worth notice in this country, by which they are enabled to make ornaments from "peat!" It appears that the peat when taken from the bog, is reduced by beating to a fine pulp, and is then placed under a press, to force out all humidity, except such as is necessary to keep it sufficiently moist to receive impressions in the mould in which it is placed. In this state it may be converted into ornaments of every kind, such as are made in embossed leather. Rendered firm by a solution of alum, or other adhesive materials, it forms flooring of a cheap and durable kind. Of billiard tables, too, there are various specimens; a rich and beautiful one has been produced in France, valued at 15,000*l.* May not

Ireland, with its ample bogs, also turn this novelty in manufactures to advantage.

#### Atmospheric Pile Driving.

Dr. Potts, of England has invented a new method of pile driving in hard sands, which promises to be of great advantage in the building of light houses, breakwaters, and wharfs. The invention consists in using a hollow cylindrical pile and exhausting it of all its air, when it has been found to descend as if by magic, while other piles in the same place took 46 blows of a ram of 112 lbs. with a fall of 10 feet. Upon this principle the inventor has founded a system of marine architecture, which promises to be of immense importance and will lead to the erection of sea and river works and the reclamation of land, which never could have been effected by any other means, and the security of foundations thus formed, and the rapidity and economy of their construction, is said to be astonishing.

#### Cachu Lozenges.

These agreeable troches of lozenges, may be easily prepared at home. For sweetening the breath after smoking, drinking or taking offensive medicines, they defy competition; the following original formula has been used with admirable success:—Take of cinnamon in very fine powder one drachm, cloves in powder one scruple, nutmegs (powdered) ten grains; powdered cardamom seeds twenty grains, double refined loaf sugar two drachms.—Reduce the ingredients to an impalpable powder, mix and sift them well together; then add oil of rose ten drops, oil of cinnamon three drops, and water sufficient to make a stiff paste then divide the mixture into lozenges of about three grains each.

Earth is eaten as bread in several parts of the world. Near Moscow, a hill furnishes earth of this description, which will ferment when mixed with flour.

Insects breathe through holes or pores on each side of every segment of the abdomen, called spiracula.

### THE NEW YORK SCIENTIFIC AMERICAN:

This paper, the most popular weekly publication of the kind in the world, is published At 128 *Fulton Street, New York, and 13 Court Street, Boston,*

#### BY MUNN & COMPANY.

The principal office being at New York.

The SCIENTIFIC AMERICAN is the Advocate of Industry in all its forms, and as a Journal for Mechanics and Manufacturers, is not equalled by any other publication of the kind in the world.

Each number contains from FIVE to SEVEN ORIGINAL MECHANICAL ENGRAVINGS of the most important inventions; a catalogue of AMERICAN PATENTS, as issued from the Patent Office each week; notices of the progress of all new MECHANICAL and SCIENTIFIC inventions; instruction in the various ARTS and TRADES, with ENGRAVINGS; curious PHILOSOPHICAL and CHEMICAL experiments; the latest RAILROAD INTELLIGENCE in EUROPE and AMERICA; all the different MECHANICAL MOVEMENTS, published in a series and ILLUSTRATED with more than A HUNDRED ENGRAVINGS, &c. &c.

This Journal is not only useful to the Mechanic and Manufacturer, but instructive to the Farmer, apprising him of all the improvements in Agricultural Implements, besides to instruct him in all the Mechanical Trades.—As a family paper, the Scientific American will convey more useful Intelligence to children and young people, than ten times its cost in schooling, and as a text book for future reference, (it being in quarto form, paged, and suitably adapted to binding,) each volume will contain as much useful information as a large library.

The Scientific American has already attained the largest circulation of any weekly mechanical journal in the world, and in this country its circulation is not surpassed by all the other mechanical papers combined.

For term see inside.